

Cylinders

Lifting Products

Pumps

Control Valves

System Components

Presses

Pullers

Specialty Tools

Cutters

Bolting Tools

Flange Maintenance

Heavy Lifting Technology

On-site Machining



**400+ PAGES FILLED
WITH OVER 2,000 TOOLS**

US E330

Introduction

The Right Tool 2-3

Cylinders (Hydraulic) 4-83

Introduction 4-5

RC-Series TRIO, Single-Acting Cylinders 6-9

RC-Series TRIO, Cylinder Accessories 10

RA-Series, Aluminum Cylinders Introduction 11

RAC-Series, Single-Acting Aluminum Cylinders 12-13

RACL-Series, Single-Acting
Aluminum Lock-nut Cylinders 14-15

RACH-Series, Single-Acting Aluminum Hollow Cylinders 16-17

RARH-Series, D/A Aluminum, Hollow Plunger Cylinders 18-19

RAR-Series, Double-Acting Aluminum Cylinders 20-21

CULP-Series, Ultra-Flat Cylinders 22

CUSP-Series, Ultra-Flat, High Tonnage Cylinders 23

LPL-Series, Single-acting Low Height Lock-Nut Cylinders 24-25

RSM/RCS-Series, Single-Acting Low Height Cylinders 26-27

RLT-Series, Low-Height Telescopic Cylinders 28-29

RT-Series, Telescopic Cylinders 30-31

BRC-/BRP-Series, Single-Acting Pull Cylinders 32-33

RCH-Series, Single-Acting Hollow Plunger Cylinders 34-35

RRH-Series, Double-Acting Hollow Plunger Cylinders 36-37

RD-Series, Double-Acting Precision Cylinders 38-39

RR-Series, Double-Acting Cylinders 40-43

HTC-Series High-Tonnage Cylinders Intro 44-45

High-Tonnage Cylinders Quick Selection Chart,
HCG, HCR, HCL, HCRL-Series 46-47

HCG-Series, Single-Acting High-Tonnage Cylinders 48-51

HCR-Series, Double-Acting High-Tonnage Cylinders 52-55

HCL-Series, S/A, High-Tonnage Lock Nut Cylinders 56-59

HCRL-Series, D/A, High-Tonnage Lock Nut Cylinders 60-61

SC-Series, Cylinder-Pump Sets 62-63

RC, P, V-Series, Extreme Environment Products 64

SC, SL, SR, SW-Series, Portable Hydraulic Toolbox 65

JH/JHA-Series, Aluminum & Steel Jacks 66

GBJ-Series, Industrial Bottle Jacks 67

PR-Series, Pow'R Riser® 68-69

PL-Series, Pow'R LOCK™ 70-71

BLS-Series, Double-Acting Climbing Jacks 72-73

SCJ-Series, Self-Locking Cube Jack 74-77

LH-Series Skidding Systems 78-81

ETT-Series, Turntables 82

Custom Hydraulic Cylinders 83

Pumps and Directional Control Valves 84-145

Introduction 84-85

P-Series, Lightweight Hand Pumps 86-87

P-Series, ULTIMA Steel Hand Pumps 88-89

P-Series, Low-Pressure Hand Pumps 90-91

P-Series, Lightweight Foot Pump 92

MP-Series, Multifluid Hand Pumps 93

P- and 11-Series, Ultra-High Pressure Hand Pumps 94-95

XC-Series, Cordless Pump 96-97

ZC-Series, Cordless Hydraulic Pumps 98-99

PU-Series Economy Pumps 100-101

E-Series, E-Pulse Electric Pump 102-103

Z-Class Electric Pump Intro 104-105

ZU-Series, Electric Pumps 106-111

ZE-Series, Electric Pumps 112-117

8000-Series (PE), Electric Pumps 118-119

PA & PAM-Series, Air Hydraulic Pumps 120-121

PA-Series, Turbo II Air Pumps 122-123

XA-Series Air Pumps 124-125

ZA-Series, Air Hydraulic Pumps 126-127

ZG-Series Gasoline Powered Pumps 128-130

8000-Series (EGM), Gasoline Powered Pumps 131

SFP-Series Split Flow Pumps 132-135

EVO-Series, Synchronized Lifting Systems 136-137

Custom Hydraulic Pumps 138

Pump Mounted Directional Control Valves 139-145

Introduction 139

VM, VE-Series, Pump-Mounted Valves 140-141

VC-Series, Remote Mounted Valves 142

VC, VM, VE Valve Dimensions 143

VE-Series, Solenoid Operated Modular Valves 144-145

System Components and Control Valves 146-165

Introduction 146-147

High-Pressure Hoses 148-149

Hydraulic Couplers 150-151

Hydraulic Oil, Manifolds and Fittings 152-155

GF and GP-Series, Hydraulic Force
and Pressure Gauges 156-157

G & H-Series, Hydraulic Pressure Gauges 158-159

T-Series, Test System Gauges 160

DGR-Series, Digital Hydraulic Gauges 161

GA45GC Gauge Adaptor Assembly 162

GA, NV, V Gauge Accessories 163

V-Series Flow & Pressure Control Valves 164-165

Hydraulic Presses 166-181

Introduction 166-167

IP-Series, H-Frame Presses 168-171

IPR-Series, Roll Frame Presses 172-173

A-Series, C-Clamps and Arbor Presses 174-175

Press Accessories 176

Press Speed Chart 176

Custom Built Presses 177

VLP & XLP-Series Presses 178-179

TM, LH Tension Meter and Load Cells 180

Custom Hydraulic Presses 181

Pullers (Mechanical and Hydraulic) 182-201

Introduction 182-183

BHP-Series, Hydraulic Puller Sets 184-187

Sync Grip Pullers Introduction 188-189

SGM-Series Mechanical Sync Grip Pullers 190

MPS-Series Master Puller Sets 191

GPS-Series Hydraulic Puller Sets 192

BHP-Series Cross Bearing Puller Sets 193

LGM-Series, Mechanical Lock-Grip Pullers 194-195

LGH-Series, Hydraulic Lock-Grip Pullers 196-197

LGH-Series, Hydraulic Master Lock-Grip Pullers 198-199

LGHMS-Series, Hydraulic Master Lock-Grip Pullers 199

IPM-Series Internal Mechanical Pullers 200

EPH-Series, Posi-Lock® 100-Ton Hydraulic Grip Pullers 201

Specialty Tools (Mechanical and Hydraulic) 202-219

Introduction 202-203

MS-Series, Maintenance Sets 204-207

SP, MSP, STP-Series, 35-Ton Hydraulic Punch 208-209

SP-Series, 50-Ton Hydraulic Punch 210-211

LW-Series, Vertical Lifting Wedge 212

SOH-Series, Hydraulic Machine Lifts 213

ER, ES and ELP-Series, Heavy-Duty Load Skates 214-215

CM-Series, Storage Cases 216

A, WR-Series, Wedgies & Spread Cylinders 217

STB-Series, Pipe Benders 218-219

Cutters 220-237

Introduction 220-221

EBH-Series, Hydraulic Bar Cutters 222-223

EBE-Series, Electric Bar Cutters 224

EBC-Series, Cordless Bar Cutters 225

EDCH-Series Decommissioning Cutters 226

EFBE-Series, Flat Bar Cutters 227

ECCE-Series, Chain Cutters 228-229

EWCH-Series, Hydraulic Wire and Cable Cutters 230-231

EWCE-Series, Electric Wire and Cable Cutters 232

ECSE-Series, Cutter/Spreader Combination Tools 233

WHC, WHR, STC-Series, Hydraulic Cutter Head 234

WMC-Series, Self-Contained Hydraulic Cutters 235

Pumps/Accessories for EWCH, EBH, EDHC-
Series Cutters 236-237

Bolting Tools 238-341

Introduction 238-239

S-Series X-Edition, Square Drive Steel
Torque Wrenches 240-243

TSP, RTE, SRSX Accessories for S-Series
X-Edition Torque Wrenches 243

BSH-Series Sockets 244

BUS-Series, Back-Up Spanners 245

STTL-Series, Safe T™ Torque Lock 246-247

W-Series X-Edition, Low Profile Hexagon
Torque Wrenches 248-249

W-Series Hexagon Cassettes 250-257

W-SL-Series, Ultra Slim Cassettes 258-259

TSP, WTE, WRP Accessories for W-Series
X-Edition Torque Wrenches 260

Bolting Application Ideas 261

RSL-Series, Low-Profile Cassettes 262

RSL Drive Units for Hexagon & Square Drive Cassettes 263

RSL-Series Hexagon Cassettes 264-268

Accessories for RSL wrenches, ERA, ERT 269

RSL-Series, Slimline Hexagon Cassettes (RLP-SL) 270-271

RSL-Series, Square Drive Torque Wrenches, RSQ 272-273

DSX-Series, Square Drive Torque Wrenches 274-275

DSX-Series, Allen® Wrenches (DDA) 276

Bolting Applications & Portable Machining 277

HMT-Series, Modular Torque Wrenches 278

Drive Units for Hexagon & Square Drive Cassettes 279

HL-Series Hexagon Cassettes for HMT Drive Units 280-281

HMT-Series Square Drive Hydraulic Torque
Wrenches/HSQ Cassettes) 282-283

E-Series Manual Torque Multipliers 284-285

PTW-Series Pneumatic Torque Wrenches 286-287

PTW-Series Torque Wrench Accessories 288-289

MCS-Series, Mobile Calibration System 290

Torque Wrench & Pump Selection Chart 291

XC-Series, Cordless Torque Wrench Pump 292-293

E-Series, E-Pulse Electric Torque Wrench Pump 294-295

TQ700 Series Electric Torque Wrench Pump 296-297

ZU4T-Series, Electric Torque Wrench Pumps 298-301

ZE-Series, Torque Wrench Pumps 302-303

LAT-Series, Air Hydraulic Torque Wrench Pumps 304-305

ZA4T-Series, Air Driven Torque Wrench Pumps 306-309

HM-Series, Hydramax Topside Bolt Tensioners 310-313

GT-Series, Hydraulic Bolt Tensioners 314-315

EAJ-Series, Aquajack Subsea Tensioners 316-317

PGT-Series, Power Generation Bolt Tensioners 318-319

FTR-Series, Foundation Bolt Tensioners 320-321

FTE-Series, Foundation Bolt Tensioners 322-323

HPT-Series Pump and Accessories 324

HT, B, Ultra High-Pressure Hoses and Couplers 325

Multi-Stage Tensioners Awareness 326

ATP -Series, Ultra-Pressure Air Hydraulic Pump 327

ZUTP-Series, Electric Tensioning Pump 328-329

ATM-Series, Flange Alignment Tools 330-331

FSM, FSH, FSC-Series Hydraulic and Mechanical
Industrial Spreaders 332-333

NC-Series, Hydraulic Nut Splitters 334-335

NSC, NSH-Series Integral & Hydraulic Nut Splitters 336-337

NSH-Series Hydraulic Nut Splitters (S/A & D/A) 338-339

FF-Series, Mechanical Flange Face Tool 340-341

Flange Maintenance Tools 342-357

Introduction 342-343
 SWi, Flange Spreading Tools 344-345
 SWi, Flange Spreading Tools (ATEX) 346-347
 SG-Series, Flange Spreading Tools 348-351
 VC-Series, Valve Change-Out Tools 352-353
 MG-Series Flange Spreading Tools 354
 FC-Series, Flange Pulling Tool 355
 TFA-Series, Flange Alignment Tools (Wind Turbine Tower) 356
 HP-Series, Hand Pumps and Hoses 357

Heavy Lifting Technology 358-377

Introduction 358-359
 LH, HSK-Series, Skidding Systems 360-361
 HSL-Series, Strand Jacks 362-363
 SL, SBL-Series, Hydraulic Gantries 364-365
 JS-Series, Jack-Up System 366-367
 SHS/SHAS-Series, SyncHoist System 368-369
 ETR-Series, Trolley System 370-371
 SPMT-Series, Self-propelled Modular Transporter 372
 Lifting Solutions 373-377

On-Site Machining Tools 378-397

Introduction 378-379
 FF, MM-I Series, Internal Mount Flange Facing Machines . 380
 MM-E Series, External Mount Flange Facing Machines . . 381
 DLR-Series, Clamshell Pipe Cutting
 & Beveling Machines 382-383
 OM-Series, General Orbital Milling Machines 384
 WP-Series, Wind Power Orbital Milling Machines 385
 LMR, MR, MRY, GM-Series, Linear Milling Machines 386-387
 HTM, LPH, MHT, CHT, LSA-Series, Hot Tapping Machines
 & Line Stopping Actuators 388-389
 MWDS Decommissioning Diamond Wire
 & Band Saws 390-391
 HT, T, DDU-Series, Drilling & Tapping Machines 392-393
 GeniSYS IV Portable 3-Axis CNC Mill 394-395
 MITT-Series, Isolation and Test Tools 396-397

Yellow Pages (Information Section) 398-417

Warranty Statement, Introduction and Standards 398-399
 Safety Instructions 400-401
 Cylinder & Pump Matching and Selection Chart 402
 Hydraulic Work Sheet 403
 Basic Hydraulic System Set-ups 404-405
 Basic Hydraulics 406-407
 Conversion Tables 408
 Cylinder Speed Charts 409
 Valve Information 410
 Hexagon Nut and Bolt Sizes 411
 Bolting Tightening & Tensioning 412-415
 Bolting Integrity Software 416-417
 Enerpac Academy 418-419
 Enerpac Worldwide Locations 420

All information in this catalog can be changed due to product improvements without prior notice.

© Copyright 2021, Enerpac Tool Group. All rights reserved. Any copying or other use of material in this catalog (text, illustrations, drawings, photos) without express written consent is prohibited.



Cylinders & Lifting Products

Page 4-83



Pumps & Directional Control Valves

Page 84-145



System Components & Control Valves

Page 146-165



Presses

Page 166-181



Pullers

Page 182-201



Specialty Tools

Page 202-219



Cutters

Page 220-237



Bolting Tools

Page 238-341



Flange Maintenance Tools

Page 342-357



Heavy Lifting Equipment

Page 358-377



On-Site Machining Tools

Page 378-397

ENDLESS INNOVATION RESULTS IN THE RIGHT TOOL

CUSTOMER-DRIVEN INNOVATION

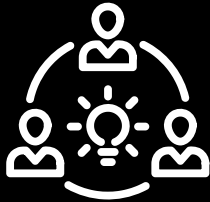

We believe it takes advanced technical expertise and ingenuity to develop the industry's most trusted solutions. Our relentless pursuit to deliver the highest standard of excellence means never compromising on quality. Yet, it all starts with a thorough understanding of our customer needs, the environments they work in and the ideas of tomorrow that help get jobs done faster, easier and safer.

INDUSTRY LEADING TECHNOLOGY

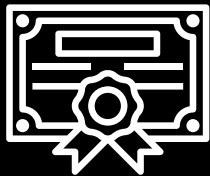

SOLVING CUSTOMER PROBLEMS

One of our core values is to continually innovate and solve customer problems. That all begins with the discovery process. Through the efforts of a dedicated innovation team and several centers of excellence, new ideas are uncovered by listening to our customer's pain points and observing how they perform tasks in their own environments. These inputs lead to the forming of ideas and eventually prototypes that can be tested, refined and transformed into finished products.

CONTINUOUS IMPROVEMENTS

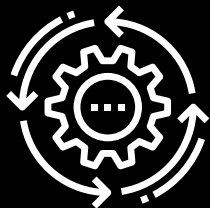

FIND OUR NEWEST PRODUCTS AT ENERPAC.COM/INNOVATION

Continuous improvement means new products are introduced and made available to customers on a regular basis throughout the year. Find the newest Enerpac products at Enerpac.com/Innovation.

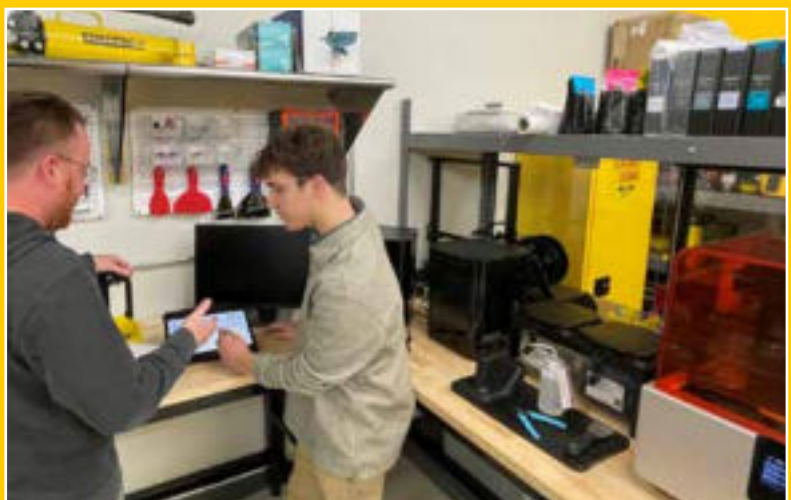

THE RIGHT TOOL MAKES ALL THE DIFFERENCE

Backed by a global legacy of ultra-reliable quality and superior precision, Enerpac is pushing the industry forward with a wide range of advanced industrial tools and services that first and foremost ensure our customers operate safely and productively every day. It isn't about being compliant. Or "as good" as the next guy; we outpace the competition by delivering technically superior solutions that are easy to get, safe to use and built to outlast.

NEVER COMPROMISE

Enerpac combines technical excellence with proven performance – every day, every year, year after year. We believe customers shouldn't have to compromise – they can rest easy knowing that even in the most complex situations, their reputations and productivity are protected by the most trusted industrial tools available.

SAFETY AND PRODUCTIVITY

Our customers put their physical well-being and reputations on the line each day they go to work; we take the fact that they put their trust in us very seriously. Enerpac team members are obsessively committed to developing solutions that keep the world's workers safe and productive in highly demanding working conditions.

ON-DEMAND ACCESS

For us, offering the ideal customer experience means working overtime to make sure our customers can be heroes when it matters most by providing on-demand access to a vast catalog of products and services, extensive training and mobilized field teams no matter where they are in the world.

As a global market leader in high-pressure hydraulic tools, controlled force products and solutions for precision positioning of heavy loads, Enerpac products have maintained and moved some of the largest structures on earth. They are the industry standard in aerospace, infrastructure, manufacturing, mining, oil & gas, power generation and much more.

Enerpac hydraulic cylinders are available in hundreds of different configurations. Whatever the industrial application... lifting, pushing, pulling, bending, holding... whatever the force capacity, stroke length, or size restrictions... single- or double-acting, solid or hollow plunger, you can be sure that Enerpac has the cylinder to suit your high force application.

Enerpac jacking cylinders fully comply to ASME B30.1 (except RD-Series).



With the 3rd Generation comes a trio of key features

The next evolution of the legendary Enerpac RC-Series hydraulic cylinder. The driving force of the Enerpac cylinder range, the new **RC-TRIO** is as **versatile** as ever.

Featuring a new TRIO Bearing System for **enhanced durability** and a hybrid spring-return system for **faster retraction** and even **greater productivity**.

NEW RC-SERIES TRIO CYLINDERS

New TRIO Bearing System

- Includes up to 4 high-performance wear bands that offer increased resistance to damage, reducing bearing load and increasing cylinder lifespan
- Hardened composite material wear bands increase bearing surface area for greater side-load resistance - significantly improving cylinder life
- New high-performance Polyethylene seals provide longer life, reducing downtime

New TRIO Stop Ring

- Part of the TRIO Bearing System, the TRIO Stop Ring includes an additional wear band of high-strength bronze to absorb greater side load
- Capable of taking full cylinder extension force
- Features durable wiper to help prevent contamination from entering the cylinder during retract cycles

New TRIO Spring System

- Hybrid pre-tensioned return springs for up to 3x faster retraction and increased productivity
- High-strength steel wire improves spring life
- Spring retention design improves serviceability while allowing higher pre-load during assembly
- Spring is easily removed without special tools

Durable Piston Rod

- High-strength steel plunger for improved life and sideload resistance
- Nickel-plated plunger coating improves corrosion protection
- Internal plunger threads for easy tool fixturing

Enhanced Ergonomics

- Standard carry handles on cylinders from 33 up to 55 lbs. Sizes above include certified lifting eyes or optional handles
- Collar threads, plunger threads and base mounting holes enable easy fixturing (on most models)

Improved Saddle Retention

- Hardened plunger saddle protects plunger end during all lifting operations
- Easily removable for access to plunger mounting threads
- Tilt and smooth saddles available as accessories (compatible with new range of CATS-Series Tilt Saddles)

Enduring Compatibility



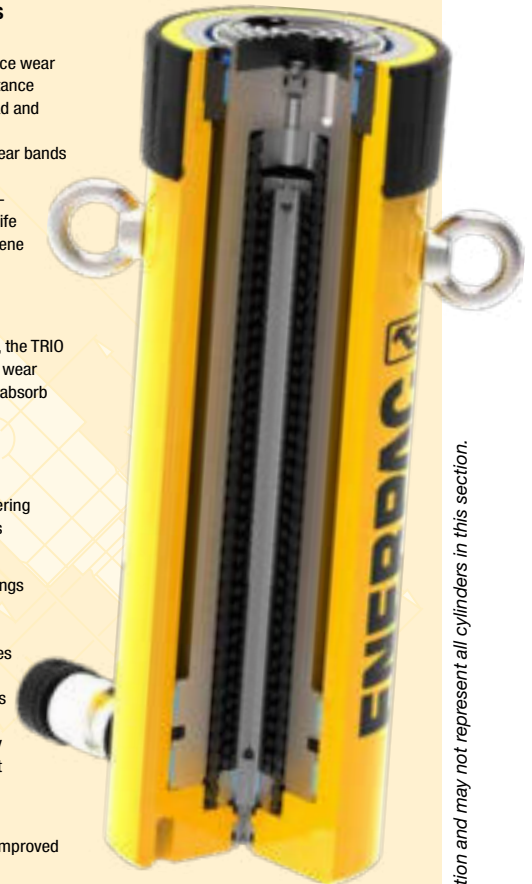













- For full compatibility and peace of mind, the new RC-Series model numbers, external dimensions and threads remain unchanged from prior RC-Series cylinders. Ensuring compatibility with historical versions and systems.



Note: The cut-away drawing is representative of typical cylinder construction and may not represent all cylinders in this section.



Cylinder & Lifting Products Section Overview

* Capacity (tons)	Stroke Range (in)	Cylinder Type and Functions	Series		Page
5-100	0.63-14.25	General Purpose Cylinders, Single-acting Accessories: Saddles, Base Plates, Mounting Attachments	RC A, CATS JBI, RE		6 10
10-150	1.97-9.84	Aluminum Cylinders Single-Acting, Lock Nut, Hollow Plunger	RAC, RACL RACH		12 14 16
20-150	1.97-9.84	Aluminum Cylinders Double-Acting Hollow Plunger Double-Acting Solid Plunger	RARH RAR		18 20
10-100 10-1000	0.24 0.26-0.69	Ultra-Flat Cylinders, Single-Acting, Load-Return with Stop-Ring or Tilting Function	CULP CUSP		22 23
60-500 5-150	1.77-1.97 0.25-2.44	Low-Height Lock Nut Cylinders Low-Height Cylinders, Single-Acting, Spring-Return	LPL RSM/ RCS		24 26
4.8-81.7 15.4-34.8	0.67-1.57 10.63-23.62	Low-Height Telescopic Cylinders Multi-Stage Telescopic Cylinders	RLT RT		28 30
2.5-60	5.00-6.00	Pull Cylinders, Single-Acting, Spring-Return	BRC BRP		32
12-100 30-150	0.31-6.13 1.50-10.13	Hollow Plunger Cylinders Single- and Double-Acting	RCH RRH		34 36
4-25 10-500	1.13-10.25 2.25-48.00	Precision Production Cylinders, Double-Acting Long Stroke Cylinders, Double-Acting	RD RR		38 40
50-1000	1.97-11.81	High-Tonnage Cylinders Single-Acting and Double-Acting	HCG HCR		48 52
50-1000 50-300	1.97-11.81 5.91-11.81	High-Tonnage, Lock Nut Cylinders, Single-Acting and Double-Acting	HCL HCRL		56 60
5-50 7-100 2-110	1.50-14.25 2.00-6.00 0.44-10.13	Cylinder Pump Sets, Single-Acting Extreme Environment Products Portable Hydraulic Toolbox	SC RC, P, V SCR, SCL, SRS		62 64 65
	3.00-6.13 2.44-18.11	Aluminum and Steel Jacks Industrial Bottle Jack	JH, JHA GBJ		66 67
60-200 200	14-26.5 14-24.5	POW'R-RISER® Lifting Jack Pow'R-LOCK™ Portable Lift System	PR PL		68 70
55-220 56-110	5.91-6.34 81.4-118.3	Climbing Jacks Self-Locking Cube Jack	BLS SCJ		72 74
400	23.5	Low-Height Skidding Components	LH		78
225-450		Hydraulic Turntables	ETT		82

* All ton values specified in this catalog are approximate and for cylinder class identification only. Please refer to the (maximum) value in US short tons for calculations

▼ Shown from left to right: RC2510, RC53, RC1002, RC108, RC5010, and RC156



- **TRIO Bearing System with hardened composite wear bands for optimal side-load resistance**
- **Strengthened TRIO Stop Ring improves durability and side-load resistance**
- **TRIO Hybrid pre-tensioned spring system provides faster retraction**
- **High-grade polyethylene seals for low wear and long service life**
- **Plunger wiper reduces contamination, extending cylinder life**
- **Collar and plunger threads and base mounting holes enable easy fixturing (on most models)**
- **Certified lifting eyes on cylinder models weighing over 55 lbs. Interchangeable with optional CHM6 carrying handle**
- **Designed for use in all positions**
- **Baked enamel finish for increased corrosion resistance**
- **CR-400 coupler and dust cap included on all models**

The Industry Standard General Purpose Cylinder



Saddles

All **RC** cylinders (except RC50, 101) are equipped with hardened removable grooved saddles. For tilt and flat saddles, see the RC-Series accessory page.

All CATS-Series Tilt Saddles use a nitrocarburization surface treatment for improved corrosion protection.

Page: 10



Base Plates

To ensure the stability of cylinders for lifting applications, base plates are available for 10, 25 and 50-ton RC cylinders.

Page: 10



Specialty Attachments

For solving all kinds of application problems, specialty attachments are available for 5, 10 and 25-ton RC cylinders.

Page: 206

▼ To re-stabilize the foundation, the 308-ton silo needed to be lifted, levelled and structurally supported. Twenty-five ton RC-Series hydraulic cylinders were attached to a bracket on the top of each steel pier. Powered by a Z-Class pump, the hydraulic cylinders applied 20 tons of force at each placement to lift the silo two inches.



▼ Synchronous lifting set-up for 200-ton petrochemical process module using twelve RC2510 cylinders. To ensure the stability of the cylinders JBI25 base plates are installed.



Single-Acting, General Purpose Cylinders



Optional Carrying Handle CHM6

Certified lifting eyes on cylinder models weighing 55 lbs. and above (RC5010 and heavier models). Interchangeable with optional carrying handle. Order model number **CHM6**.

▼ QUICK SELECTION CHART

For complete technical information see next page.

Cylinder Capacity tons (maximum)	Stroke (in)	Model Number	Cylinder Effective Area (in ²)	Oil Capacity (in ³)	Collapsed Height (in)	Weight (lbs)
5 (4.9)	0.63	RC50	0.99	0.62	1.63	2.2
	1.00	RC51	0.99	0.99	4.34	2.3
	3.00	RC53	0.99	2.97	6.50	3.3
	5.00	RC55*	0.99	4.95	8.50	4.1
	7.00	RC57	0.99	6.93	10.75	5.3
	9.13	RC59	0.99	9.04	12.75	6.1
10 (11.2)	1.00	RC101	2.24	2.24	3.53	4.0
	2.13	RC102*	2.24	4.76	4.78	5.1
	4.13	RC104	2.24	9.23	6.75	7.2
	6.13	RC106*	2.24	13.70	9.75	9.8
	8.00	RC108	2.24	17.88	11.75	12.0
	10.13	RC1010*	2.24	22.64	13.75	14.0
	12.00	RC1012	2.24	26.82	15.75	15.0
	14.00	RC1014	2.24	31.29	17.75	18.0
15 (15.7)	1.00	RC151	3.14	3.14	4.88	7.2
	2.00	RC152	3.14	6.28	5.88	9.0
	4.00	RC154*	3.14	12.57	7.88	11.0
	6.00	RC156*	3.14	18.85	10.69	15.0
	8.00	RC158	3.14	25.13	12.69	18.0
	10.00	RC1510	3.14	31.42	14.69	21.0
	12.00	RC1512	3.14	37.70	16.69	24.0
	14.00	RC1514	3.14	43.98	18.69	26.0
25 (25.8)	1.00	RC251	5.16	5.16	5.50	13.0
	2.00	RC252*	5.16	10.32	6.50	14.0
	4.00	RC254*	5.16	20.64	8.50	18.0
	6.25	RC256*	5.16	32.25	10.75	22.0
	8.25	RC258	5.16	42.56	12.75	27.0
	10.25	RC2510	5.16	52.88	14.75	31.0
	12.25	RC2512	5.16	63.20	16.75	36.0
	14.25	RC2514*	5.16	73.52	18.75	39.0
30 (32.4)	8.25	RC308	6.49	53.56	15.25	40.0
50 (55.2)	2.00	RC502	11.04	22.09	6.94	33.0
	4.00	RC504	11.04	44.18	8.94	42.0
	6.25	RC506*	11.04	69.03	11.13	51.0
	10.25	RC5010	11.04	113.21	15.13	70.0
	13.25	RC5013	11.04	146.34	18.13	83.0
75 (79.5)	6.13	RC756	15.90	97.49	11.25	65.0
	13.13	RC7513	15.90	208.82	19.38	130.0
100 (103.1)	2.00	RC1002	20.63	41.26	8.63	81.00
	6.63	RC1006	20.63	136.77	14.06	130.0
	10.25	RC10010	20.63	211.45	17.69	160.0

* Available as a set. See note on this page.

RC-TRIO Series



Capacity:

5 - 100 tons

Stroke:

0.63 - 14.25 inches

Maximum Operating Pressure:

10,000 psi



Think Safety

Manufacturer's rating of load and stroke are maximum safe limits.

Good practice encourages using only 80% of these ratings!

Page: 404



Lightweight Aluminum Cylinders

If you need a higher cylinder capacity-to-weight-ratio the RAC-Series are the perfect choice.

Page: 12



Gauges

Minimize the risk of overloading and ensure long, dependable service from your equipment. Refer to

the System Components section for a full range of gauges.

Page: 151

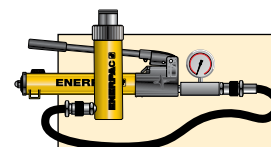

Pump and Cylinder Sets

All cylinders marked with an * are available as sets (cylinder, gauge, couplers, hose and pump) for your ordering convenience.

Page: 63



Speed Chart and Pump Selection Chart

See the Enerpac Cylinder Speed Chart in our "Yellow Pages" to determine your approximate cylinder speed. See Pump Selection Tool on website to choose the most suitable pump for your application.

Page: **409**

◀ For full features see page 6.

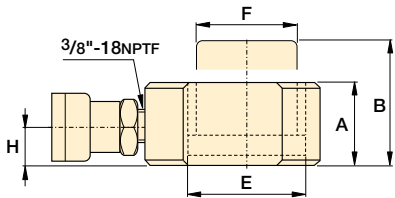
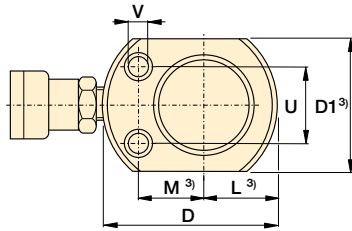

RC50

RC101 only
(U1 = 0.75 inch)

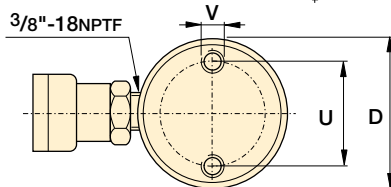
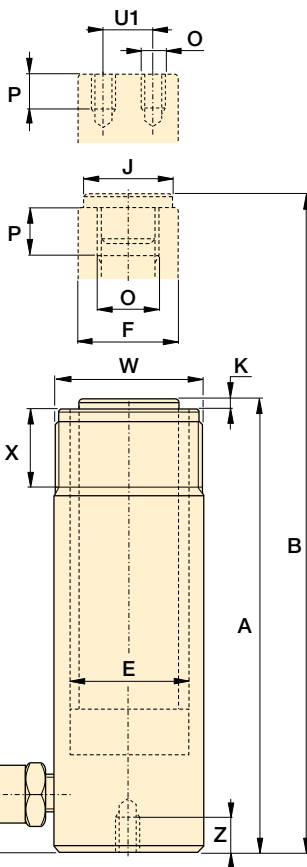

RC51 to RC5013 models

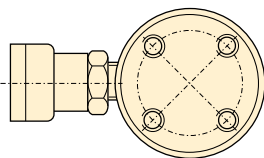

RC1002 and RC10010 models

Cylinder Capacity	Stroke	Model Number	Cylinder Effective Area	Oil Capacity	Collapsed Height	Extended Height	Outside Diameter
tons (maximum)	(in)		(in ²)	(in ³)	A (in)	B (in)	D (in)
5 (4.9)	0.63	RC50 ²⁾	0.99	0.62	1.63	2.25	2.31 ³⁾
	1.00	RC51	0.99	0.99	4.34	5.34	1.50
	3.00	RC53	0.99	2.97	6.50	9.50	1.50
	5.00	RC55 ¹⁾	0.99	4.95	8.50	13.50	1.50
	7.00	RC57	0.99	6.93	10.75	17.75	1.50
10 (11.2)	9.13	RC59	0.99	9.04	12.75	21.88	1.50
	1.00	RC101 ⁴⁾	2.24	2.24	3.53	4.53	2.25
	2.13	RC102 ¹⁾	2.24	4.76	4.78	6.91	2.25
	4.13	RC104	2.24	9.23	6.75	10.88	2.25
	6.13	RC106 ¹⁾	2.24	13.70	9.75	15.88	2.25
	8.00	RC108	2.24	17.88	11.75	19.75	2.25
	10.13	RC1010 ¹⁾	2.24	22.64	13.75	23.88	2.25
15 (15.7)	12.00	RC1012	2.24	26.82	15.75	27.75	2.25
	14.00	RC1014	2.24	31.29	17.75	31.75	2.25
	1.00	RC151	3.14	3.14	4.88	5.88	2.75
	2.00	RC152	3.14	6.28	5.88	7.88	2.75
	4.00	RC154 ¹⁾	3.14	12.57	7.88	11.88	2.75
	6.00	RC156*	3.14	18.85	10.69	16.69	2.75
	8.00	RC158	3.14	25.13	12.69	20.69	2.75
25 (25.8)	10.00	RC1510	3.14	31.42	14.69	24.69	2.75
	12.00	RC1512	3.14	37.70	16.69	28.69	2.75
	14.00	RC1514	3.14	43.98	18.69	32.69	2.75
	1.00	RC251	5.16	5.16	5.50	6.50	3.38
	2.00	RC252 ¹⁾	5.16	10.32	6.50	8.50	3.38
	4.00	RC254 ¹⁾	5.16	20.64	8.50	12.50	3.38
	6.25	RC256 ¹⁾	5.16	32.25	10.75	17.00	3.38
30 (32.4)	8.25	RC258	5.16	42.56	12.75	21.00	3.38
	10.25	RC2510	5.16	52.88	14.75	25.00	3.38
	12.25	RC2512	5.16	63.20	16.75	29.00	3.38
	14.25	RC2514 ¹⁾	5.16	73.52	18.75	33.00	3.38
	8.25	RC308	6.49	53.56	15.25	23.50	4.00
50 (55.2)	2.00	RC502	11.04	22.09	6.94	8.94	5.00
	4.00	RC504	11.04	44.18	8.94	12.94	5.00
	6.25	RC506 ¹⁾	11.04	69.03	11.13	17.38	5.00
	10.25	RC5010	11.04	113.21	15.13	25.38	5.00
75 (79.5)	13.25	RC5013	11.04	146.34	18.13	31.38	5.00
	6.13	RC756	15.90	97.49	11.25	17.38	5.75
100 (103.1)	13.13	RC7513	15.90	208.82	19.38	32.51	5.75
	2.00	RC1002	20.63	41.26	8.63	10.63	7.00
	6.63	RC1006	20.63	136.77	14.06	20.69	7.00
	10.25	RC10010	20.63	211.45	17.69	27.94	7.00

¹⁾ Available as a set. See page 62.

²⁾ RC50 cylinder has non-removable grooved saddle and no collar thread.

³⁾ RC50: D1 = 1.63 inch, L = 0.81 inch, M = 1.00 inch.

⁴⁾ RC-101 has plunger thread and non-removable saddle.

Single-Acting, General Purpose Cylinders

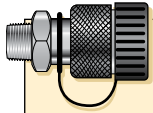

Couplers Included!
CR400 couplers included on all models. Fits all HC-Series hoses.

Capacity:
5 - 100 tons

Stroke:
0.63 - 14.25 inches

Maximum Operating Pressure:
10,000 psi

RC-TRIO Series



Cylinder Bore Diam.	Plunger Dia.	Base to Adv. Port	Saddle Dia.	Saddle Protusion from Plngr.	Plunger Internal Thread	Plunger Thread Length	Base Mounting Holes			Collar Thread	Collar Thread Length	Weight (lbs)	Model Number
							Bolt Circle U (in)	Thread V (in)	Thread Depth Z (in)				
E (in)	F (in)	H (in)	J (in)	K (in)	O (in)	P (in)	U (in)	V (in)	Z (in)	W (in)	X (in)		
1.13	1.00	0.75	2)	2)	2)	2)	1.13	0.22	—	—	—	2.2	RC50 ²⁾
1.13	1.00	0.75	1.00	0.25	3/4"-16UN	0.56	1.00	1/4"-20UNC	0.56	1 1/2"-16UN	1.13	2.3	RC51
1.13	1.00	0.75	1.00	0.25	3/4"-16UN	0.56	1.00	1/4"-20UNC	0.56	1 1/2"-16UN	1.13	3.3	RC53
1.13	1.00	0.75	1.00	0.25	3/4"-16UN	0.56	1.00	1/4"-20UNC	0.56	1 1/2"-16UN	1.13	4.1	RC55 ¹⁾
1.13	1.00	0.75	1.00	0.25	3/4"-16UN	0.63	1.00	1/4"-20UNC	0.56	1 1/2"-16UN	1.13	5.3	RC57
1.13	1.00	0.75	1.00	0.25	3/4"-16UN	0.63	1.00	1/4"-20UNC	0.56	1 1/2"-16UN	1.13	6.1	RC59
1.69	1.50	0.75	—	—	#10-24UN	0.25	1.56	5/16"-18UNC	0.50	2 1/4"-14UN	1.06	4.0	RC101 ⁴⁾
1.69	1.50	0.75	1.38	0.25	1"-8UN	0.75	1.56	5/16"-18UNC	0.50	2 1/4"-14UN	1.13	5.1	RC102 ¹⁾
1.69	1.50	0.75	1.38	0.25	1"-8UN	0.75	1.56	5/16"-18UNC	0.50	2 1/4"-14UN	1.06	7.2	RC104
1.69	1.50	0.75	1.38	0.25	1"-8UN	0.75	1.56	5/16"-18UNC	0.50	2 1/4"-14UN	1.13	9.8	RC106 ¹⁾
1.69	1.50	0.75	1.38	0.25	1"-8UN	0.75	1.56	5/16"-18UNC	0.50	2 1/4"-14UN	1.06	12	RC108
1.69	1.50	0.75	1.38	0.25	1"-8UN	0.75	1.56	5/16"-18UNC	0.50	2 1/4"-14UN	1.13	14	RC1010 ¹⁾
1.69	1.50	0.75	1.38	0.25	1"-8UN	0.75	1.56	5/16"-18UNC	0.50	2 1/4"-14UN	1.06	15	RC1012
1.69	1.50	0.75	1.38	0.25	1"-8UN	0.75	1.56	5/16"-18UNC	0.50	2 1/4"-14UN	1.06	18	RC1014
2.00	1.63	0.75	1.50	0.38	1"-8UN	1.00	1.88	3/8"-16UNC	0.50	2 3/4"-16UN	1.19	7.2	RC151
2.00	1.63	0.75	1.50	0.38	1"-8UN	1.00	1.88	3/8"-16UNC	0.50	2 3/4"-16UN	1.19	9	RC152
2.00	1.63	0.75	1.50	0.38	1"-8UN	1.00	1.88	3/8"-16UNC	0.50	2 3/4"-16UN	1.19	11	RC154 ¹⁾
2.00	1.63	1.00	1.50	0.38	1"-8UN	1.00	1.88	3/8"-16UNC	0.50	2 3/4"-16UN	1.19	15	RC156 ¹⁾
2.00	1.63	1.00	1.50	0.38	1"-8UN	1.00	1.88	3/8"-16UNC	0.50	2 3/4"-16UN	1.19	18	RC158
2.00	1.63	1.00	1.50	0.38	1"-8V	1.00	1.88	3/8"-16UNC	0.50	2 3/4"-16UN	1.19	21	RC1510
2.00	1.63	1.00	1.50	0.38	1"-8UN	1.00	1.88	3/8"-16UNC	0.50	2 3/4"-16UN	1.19	24	RC1512
2.00	1.63	1.00	1.50	0.38	1"-8UN	1.00	1.88	3/8"-16UNC	0.50	2 3/4"-16UN	1.19	26	RC1514
2.56	2.25	1.00	2.00	0.41	1 1/2"-16UN	1.00	2.31	1/2"-13UNC	0.75	3 5/16"-12UN	1.94	13	RC251
2.56	2.25	1.00	2.00	0.41	1 1/2"-16UN	1.00	2.31	1/2"-13UNC	0.75	3 5/16"-12UN	1.94	14	RC252 ¹⁾
2.56	2.25	1.00	2.00	0.41	1 1/2"-16UN	1.00	2.31	1/2"-13UNC	0.75	3 5/16"-12UN	1.94	18	RC254 ¹⁾
2.56	2.25	1.00	2.00	0.41	1 1/2"-16UN	1.00	2.31	1/2"-13UNC	0.75	3 5/16"-12UN	1.94	22	RC256 ¹⁾
2.56	2.25	1.00	2.00	0.41	1 1/2"-16UN	1.00	2.31	1/2"-13UNC	0.75	3 5/16"-12UN	1.94	27	RC258
2.56	2.25	1.00	2.00	0.41	1 1/2"-16UN	1.00	2.31	1/2"-13UNC	0.75	3 5/16"-12UN	1.94	31	RC2510
2.56	2.25	1.00	2.00	0.41	1 1/2"-16UN	1.00	2.31	1/2"-13UNC	0.75	3 5/16"-12UN	1.94	36	RC2512
2.56	2.25	1.00	2.00	0.41	1 1/2"-16UN	1.00	2.31	1/2"-13UNC	0.75	3 5/16"-12UN	1.94	39	RC2514 ¹⁾
2.88	2.25	1.13	2.00	0.41	1 1/2"-16UN	1.00	2.31	1/2"-13UNC	0.63	3 5/16"-12UN	1.94	40	RC308
3.75	3.13	1.31	2.81	0.11	—	—	3.75	1/2"-13UNC	0.75	5"-12UN	2.19	33	RC502
3.75	3.13	1.31	2.81	0.11	—	—	3.75	1/2"-13UNC	0.75	5"-12UN	2.19	42	RC504
3.75	3.13	1.38	2.81	0.11	—	—	3.75	1/2"-13UNC	0.75	5"-12UN	2.19	51	RC506 ¹⁾
3.75	3.13	1.38	2.81	0.11	—	—	3.75	1/2"-13UNC	0.75	5"-12UN	2.19	70	RC5010
3.75	3.13	1.38	2.81	0.11	—	—	3.75	1/2"-13UNC	0.75	5"-12UN	2.19	83	RC5013
4.50	3.75	1.19	2.81	0.11	—	—	4.50	5/8"-11UNC	0.63	5 3/4"-12UN	1.75	65	RC756
4.50	3.75	1.19	2.81	0.11	—	—	4.50	5/8"-11UNC	0.63	5 3/4"-12UN	1.75	130	RC7513
5.13	4.13	1.63	2.81	0.11	—	—	5.50	3/4"-10UNC	1.00	6 7/8"-12UN	1.75	81	RC1002
5.13	4.13	1.63	2.81	0.11	—	—	5.50	3/4"-10UNC	1.00	6 7/8"-12UN	1.75	130	RC1006
5.13	4.13	1.63	2.81	0.11	—	—	5.50	3/4"-10UNC	1.00	6 7/8"-12UN	1.75	160	RC10010

▼ SELECTION CHART

For Use with Cylinder Capacity (tons)	Saddles			Base Plate	Mounting Block	Clevis Eyes	
	Flat	Grooved ¹⁾	Tilt			Base ⁴⁾	Plunger
5	A53F ²⁾	A53G ²⁾	-	-	RB5 ²⁾ , AW51 ²⁾ , AW53 ²⁾	REB5 ²⁾	REP5 ²⁾
10	A12 ³⁾ , A102F ³⁾	A102G ³⁾	CATS12 ³⁾	JBI10	RB10, AW102	REB10	REP10 ³⁾
15	-	A152G	CATS12	-	RB15	REB15	REP10
25	A29 ⁽⁵⁾	A252G	CATS52	JBI25	RB25	REB25	REP25
30	A29 ⁽⁵⁾	A252G	CATS52	-	RB25	-	REP25
50	-	-	CATS100	JBI50	-	-	-
75	-	-	CATS100	-	-	-	-
95	-	-	CATS100	-	-	-	-

¹⁾ Standard on 5-30 ton RC-cylinders ²⁾ Except RC50 ³⁾ Except RC101 ⁴⁾ Mounting screws are included ⁵⁾ Used with Bender Sets.

▼ DIMENSION CHARTS

Model Number	Saddle Dimensions (in)			A53F A102F	Tilt Saddle Model Number	Addition to Collapsed Height A1 (in)	Tilt Saddle Diameter J1 (in)	
	A	B	C					
Flat								
A53F	1.00	0.25	0.68					
A102F	1.38	0.24	0.88					
A12	2.00	1.88	1"-8UNC					
A29	2.00	1.88	1½"-16UN					
Grooved								
A53G	1.00	0.25	0.68					
A102G	1.38	0.24	0.88					
A152G	1.50	0.37	0.88					
A252G	1.97	0.37	1.40					

Model Number	Base Plate Dimensions (in)					 JBI10, -25	 JBI50
	A	B	C	D	E		
JBI10	9.00	9.00	5.34	2.29	0.81		
JBI25	11.00	11.00	5.53	3.41	1.03		
JBI50	12.00	0.60	3.75	5.19	1.25		

Model Number	Mounting Block Dimensions (in)								 RB5, -10 RB15, -25	 AW51	 AW53	 AW102 (J = 0.19)
	A	B	C	D	E	F	G	H				
RB5	1½"-16	3.50	3.00	-	1.00	-	-	-				
AW51	1½"-16	2.76	2.36	0.43	0.98	2.13	¼"-20	1.62				
AW53	1½"-16	2.87	0.28	0.31	0.75	2.25	¼"-20	0.41				
RB10	2¼"-14	4.50	3.50	-	1.00	-	-	-				
AW102	2¼"-14	3.94	3.25	0.63	1.18	3.00	7/16"-20	2.31				
RB15	2¾"-16	4.00	4.50	-	1.50	-	-	-				
RB25	3⅝"-12	5.00	6.50	-	2.00	-	-	-				

Type	Model Number	Clevis Eye Dimensions (in)						Pin to Pin* (in)	 REB REP
		A	B	C	D	E	F		
Base ⁴⁾	REB5	1.75	1.88	0.56	0.63	0.63	1.00	2.37	
	REB10	2.50	2.63	1.00	0.88	1.00	1.38	3.07	
	REB15	3.00	2.63	1.00	0.88	1.00	1.38	3.07	
	REB25	3.75	3.13	1.50	1.25	1.25	1.63	3.45	
Plunger	REP5	1.13	1.75	0.56	0.63	0.63	0.75	-	
	REP10	1.69	2.43	1.00	0.88	1.00	1.13	-	
	REP25	2.25	2.81	1.50	1.25	1.25	1.38	-	

⁴⁾ Mounting screws are included

* Pin to Pin- REB and REP Clevises fitted. Add cylinder collapsed height.

The Enerpac Lightweight Aluminum Cylinders

▼ Shown: RAC, RA CL, RACH, and RAR



- **Lightweight, easy to carry and position to allow a higher cylinder capacity-to-weight-ratio**
- **Non-corrosive by design, aluminum has always been a good material for use in many caustic environments**
- **Composite bearings on all moving surfaces guarantee NO metal-to-metal contact, to resist side loads and increase cylinder life**

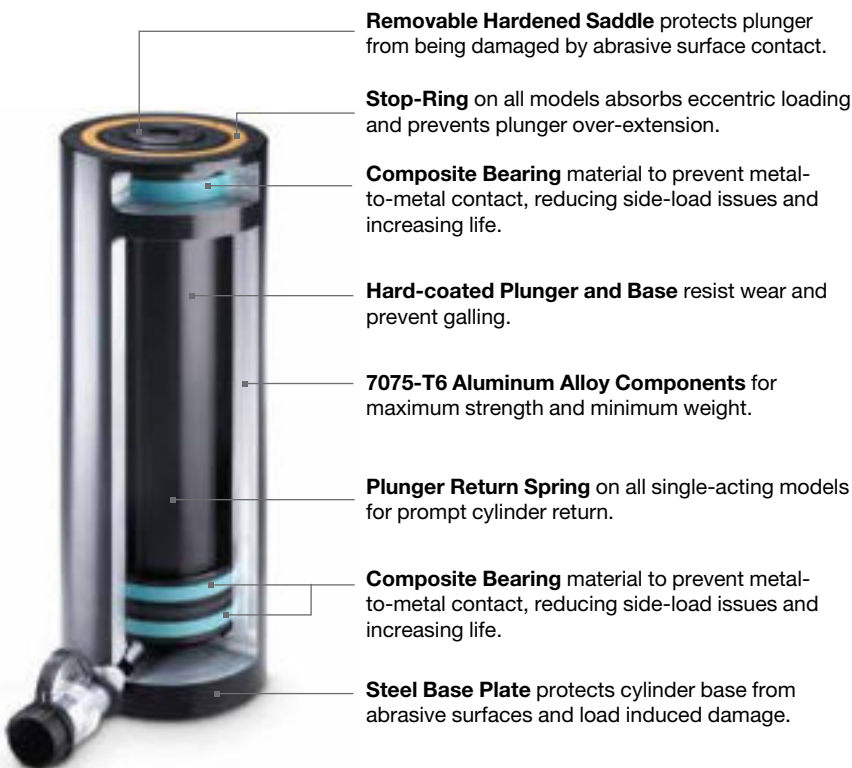

RA Series

Capacity:

10 - 150 tons

Stroke:

1.97 - 9.84 inches

Maximum Operating Pressure:

10,000 psi



Think Safety

Manufacturer's rating of load and stroke are maximum safe limits.

Good practice encourages using only 80% of these ratings!

Page: 400



Aluminum vs. Steel

Aluminum cylinders, while offering the most lightweight solution also have some unique limitations due to material properties. It differs from steel in that it has a lower finite fatigue life. Aluminum cylinders should NOT be used in high-cycle applications such as production.

These cylinders are designed to provide 5000 cycles at their recommended pressure. **This limit should not be exceeded.** In normal lifting and many maintenance applications, this should provide a lifetime of use.



Steel Base Plate

The steel base plate protects the cylinder base from damage, it should not be removed.

The base holes in these aluminum cylinders are designed for securing the steel base plate. They will not withstand the capacity of the cylinder.

Do not use the base holes in these aluminum cylinders to attach any device to the cylinder.

▼ Shown from left to right: RAC508, RAC1506, RAC304, and RAC206



Lightweight for Maximum Portability



Saddles

All RAC cylinders are equipped with bolt-on removable saddles of hardened steel.

13



Lightweight Hand Pumps

Enerpac hand pumps **P392** or **P802** make the optimal lightweight set.

Page: 86

- Composite bearings prevent metal-to-metal contact, increasing cylinder life and resistance to side-loads of up to 10%
- Hard coat finish on all surfaces resists damage and extends cylinder life
- Handles included on all models 30 tons and above
- For protection against load-induced damage, a saddle is standard on all models and a steel baseplate is standard on models 20-ton and above. The steel baseplate is optional only on 10- and 15-ton models
- Integral stop-ring prevents plunger over-travel and is capable of withstanding the full cylinder capacity
- High-strength return spring for rapid cylinder retraction
- CR400 coupler and dust cap included on all models
- All cylinders meet ASME B-30.1 standards



◀ Enerpac lightweight aluminum RAC506 cylinders are ideal for wet environments such as this tunnel under the river (Holland High-Speed Train Line).

Cylinder Capacity	Stroke*	Model Number	Cylinder Effective Area
tons (maximum)	(in)		(in ²)
10 (9.9)	1.97	RAC102	1.95
	3.94	RAC104	1.95
	5.91	RAC106	1.95
15 (15.4)	1.97	RAC152	3.03
	3.94	RAC154	3.03
	5.91	RAC156	3.03
20 (24.2)	1.97	RAC202	4.83
	3.94	RAC204	4.83
	5.91	RAC206	4.83
	7.87	RAC208	4.83
	9.84	RAC2010	4.83
30 (34.2)	1.97	RAC302	6.85
	3.94	RAC304	6.85
	5.91	RAC306	6.85
	7.87	RAC308	6.85
	9.84	RAC3010	6.85
50 (54.9)	1.97	RAC502	10.99
	3.94	RAC504	10.99
	5.91	RAC506	10.99
	7.87	RAC508	10.99
	9.84	RAC5010	10.99
100 (110.9)	1.97	RAC1002	22.19
	3.94	RAC1004	22.19
	5.91	RAC1006	22.19
	7.87	RAC1008	22.19
	9.84	RAC10010	22.19
150 (175.9)	1.97	RAC1502	35.18
	3.94	RAC1504	35.18
	5.91	RAC1506	35.18
	7.87	RAC1508	35.18
	9.84	RAC15010	35.18

* Custom strokes available.

Single-Acting, Spring-Return Cylinders

Optional Tilt Saddle Dimensions (in)			
For Cylinder Model / Capacity (ton)	Tilt Saddle Model Number*	Tilt Saddle Diameter	Addition to Collapsed Height
		J1	A1
RAC20, 30	CATS30	2.17	0.43
RAC50	CATS50	2.80	0.55
RAC100	CATS150	3.82	0.75
RAC150	CATS200	4.96	0.71

* Tilt saddle not available for 10 and 15 ton.

Optional Steel Base Plate	
Cylinder Model / Capacity (ton)	Base Plate Model Number 1)
RAC10	JBA10
RAC15	JBA15

1) Base plate height of 0.25" included on all 20-150 ton models. Base Plate is optional on 10-15 ton cylinders.

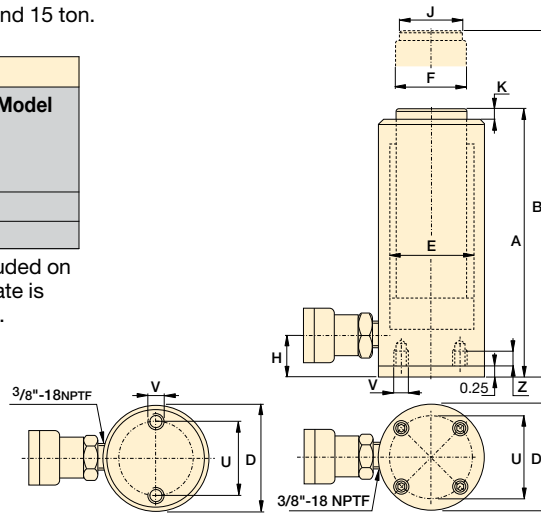

RAC102 to RAC156

RAC202 to RAC15010

RAC Series



Capacity:

10 -150 tons

Stroke:

1.97 - 9.84 inches

Maximum Operating Pressure:

10,000 psi



Steel Base Plate

The steel base plate protects the cylinder base from damage, it should not be removed. See warning on page 11.

Oil Capacity (in ³)	Collapsed Height		Extended Height	Outside Diameter	Cylinder Bore Diameter	Plunger Diameter	Base to Advance Port	Saddle Diameter	Saddle Protrusion from Plunger	Bolt Circle	Thread	Thread Depth 1)	Wt. (lbs)	Model Number
	A (in)	B (in)												
3.66	6.06	7.91	2.28	1.57	1.26	0.91	0.94	0.12	1.54	M6	0.47	2.7	RAC102	
7.93	8.03	11.97	2.28	1.57	1.26	0.91	0.94	0.12	1.54	M6	0.47	3.7	RAC104	
11.59	10.00	15.91	2.28	1.57	1.26	0.91	0.94	0.12	1.54	M6	0.47	4.4	RAC106	
6.10	6.34	8.31	2.76	1.97	1.57	0.91	1.14	0.12	1.89	M6	0.47	4.2	RAC152	
12.20	8.31	12.24	2.76	1.97	1.57	0.91	1.14	0.12	1.89	M6	0.47	5.3	RAC154	
17.69	10.28	16.18	2.76	1.97	1.57	0.91	1.14	0.12	1.89	M6	0.47	6.4	RAC156	
9.52	6.85	8.83	3.35	2.48	1.97	1.07	1.58	0.12	2.76	M6	0.47	7.9	RAC202	
19.03	8.82	12.76	3.35	2.48	1.97	1.07	1.58	0.12	2.76	M6	0.47	9.0	RAC204	
28.55	10.79	16.70	3.35	2.48	1.97	1.07	1.58	0.12	2.76	M6	0.47	10.1	RAC206	
38.01	12.76	20.64	3.35	2.48	1.97	1.07	1.58	0.12	2.76	M6	0.47	11.2	RAC208	
47.53	14.73	24.58	3.35	2.48	1.97	1.07	1.58	0.12	2.76	M6	0.47	12.3	RAC2010	
13.49	7.13	9.10	3.94	2.95	2.36	1.31	1.58	0.12	3.15	M6	0.47	9.9	RAC302	
26.99	9.09	13.04	3.94	2.95	2.36	1.31	1.58	0.12	3.15	M6	0.47	11.5	RAC304	
40.48	11.06	16.98	3.94	2.95	2.36	1.31	1.58	0.12	3.15	M6	0.47	13.0	RAC306	
53.91	13.04	20.91	3.94	2.95	2.36	1.31	1.58	0.12	3.15	M6	0.47	14.5	RAC308	
67.40	15.01	24.85	3.94	2.95	2.36	1.31	1.58	0.12	3.15	M6	0.47	16.1	RAC3010	
21.65	7.32	9.90	5.12	3.74	3.15	1.19	1.97	0.12	4.33	M6	0.47	18.7	RAC502	
43.30	9.29	13.24	5.12	3.74	3.15	1.19	1.97	0.12	4.33	M6	0.47	21.6	RAC504	
64.95	11.26	17.17	5.12	3.74	3.15	1.19	1.97	0.12	4.33	M6	0.47	24.5	RAC506	
86.49	13.24	21.11	5.12	3.74	3.15	1.19	1.97	0.12	4.33	M6	0.47	27.3	RAC508	
108.14	15.21	25.05	5.12	3.74	3.15	1.19	1.97	0.12	4.33	M6	0.47	30.2	RAC5010	
43.71	8.71	10.68	7.09	5.32	4.33	1.82	3.70	0.12	5.91	M10	0.47	38.1	RAC1002	
87.43	10.67	14.61	7.09	5.32	4.33	1.82	3.70	0.12	5.91	M10	0.47	43.2	RAC1004	
131.14	12.64	18.55	7.09	5.32	4.33	1.82	3.70	0.12	5.91	M10	0.47	48.3	RAC1006	
174.64	14.61	22.49	7.09	5.32	4.33	1.82	3.70	0.12	5.91	M10	0.47	53.4	RAC1008	
218.35	16.58	26.43	7.09	5.32	4.33	1.82	3.70	0.12	5.91	M10	0.47	58.4	RAC10010	
69.30	9.56	11.53	9.06	6.69	5.51	2.02	4.45	0.12	7.87	M10	0.47	55.8	RAC1502	
138.61	11.53	15.47	9.06	6.69	5.51	2.02	4.45	0.12	7.87	M10	0.47	64.6	RAC1504	
207.91	13.49	19.41	9.06	6.69	5.51	2.02	4.45	0.12	7.87	M10	0.47	73.4	RAC1506	
276.87	15.47	23.34	9.06	6.69	5.51	2.02	4.45	0.12	7.87	M10	0.47	82.2	RAC1508	
346.17	17.44	27.28	9.06	6.69	5.51	2.02	4.45	0.12	7.87	M10	0.47	91.1	RAC15010	

▼ Shown from left to right: RACL1006, RACL504 and RACL506



To Secure Loads Mechanically



Saddles

All RACL cylinders are equipped with bolt-on removable saddles of hardened steel. For tilt saddles see next page.

Page: 15



Hoses

Enerpac offers a complete line of high-quality hydraulic hoses. To ensure the integrity of your system, specify only Enerpac hydraulic hoses.

Page: 148

- Aluminum Lock Nut provides mechanical load holding for extended periods
- Hardened steel stop-ring increases cylinder life and resistance to side-loads of up to 5%
- Hard coat finish on all surfaces resists damage and extends cylinder life
- Composite bearings increase cylinder life and side load resistance
- Handles included on all models
- Steel base plate and saddle for protection against load-induced damage
- Integral stop-ring prevents plunger over-travel and is capable of withstanding the full cylinder capacity
- High-strength return spring for rapid cylinder retraction
- CR400 coupler and dust cap included on all models
- All cylinders meet ASME B-30.1 standards



◀ The portable Lock Nut cylinder RACL1506 used for extended load support during epoxy injection for bridge reinforcement.

Cylinder Capacity	Stroke*	Model Number	Cylinder Effective Area
ton (maximum)	(in)		(in ²)
20 (24.2)	1.97	RACL202	4.83
	3.94	RACL204	4.83
	5.91	RACL206	4.83
	7.87	RACL208	4.83
	9.84	RACL2010	4.83
30 (34.2)	1.97	RACL302	6.85
	3.94	RACL304	6.85
	5.91	RACL306	6.85
	7.87	RACL308	6.85
	9.84	RACL3010	6.85
50 (54.9)	1.97	RACL502	10.99
	3.94	RACL504	10.99
	5.91	RACL506	10.99
	7.87	RACL508	10.99
	9.84	RACL5010	10.99
100 (110.9)	1.97	RACL1002	22.19
	3.94	RACL1004	22.19
	5.91	RACL1006	22.19
	7.87	RACL1008	22.19
	9.84	RACL10010	22.19
150 (175.9)	1.97	RACL1502	35.18
	3.94	RACL1504	35.18
	5.91	RACL1506	35.18
	7.87	RACL1508	35.18
	9.84	RACL15010	35.18

* Custom strokes available.

Single-Acting, Spring-Return, Lock Nut Cylinders

Optional Tilt Saddle Dimensions (in)

For Cylinder Model / Capacity (ton)	Tilt Saddle Model Number	Tilt Saddle Diameter J1	Addition to Collapsed Height A1
RACL20, 30	CATS30	2.17	0.43
RACL50	CATS50	2.80	0.55
RACL100	CATS150	3.82	0.75
RACL150	CATS200	4.96	0.71

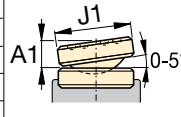

Steel Base Plate Mounting Holes

Cylinder Model / Capacity (ton)	Bolt Circle U (in)	Thread V (mm)	Thread Depth ¹⁾ Z (in)
RACL20	2.76	M6	0.47
RACL30	3.15	M6	0.47
RACL50	4.33	M6	0.47
RACL100	5.91	M10	0.47
RACL150	7.87	M10	0.47

¹⁾ Base plate height of 0.25" and (4) four base plate bolts.

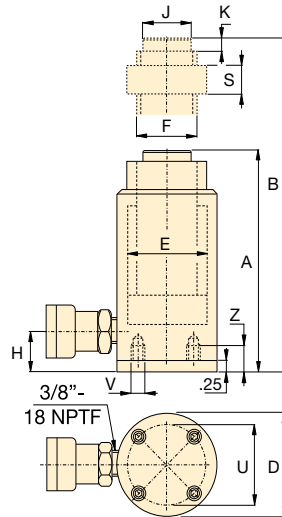

RACL Series



Capacity:

20 - 150 tons

Stroke:

1.97 - 9.84 inches

Maximum Operating Pressure:

10,000 psi



Steel Base Plate

The steel base plate protects the cylinder base from damage, it should not be removed. See warning on page 11.

Oil Capacity (in ³)	Collapsed Height A (in)	Extended Height B (in)	Outside Diameter D (in)	Cylinder Bore Diameter E (in)	Plunger Diameter (Threaded) F (in)	Base to Advance Port H (in)	Saddle Diameter J (in)	Saddle Protrusion from Plunger K (in)	Lock Nut Height S (in)	Weight (lbs)	Model Number
9.52	8.83	10.80	3.35	2.48	2.17	1.07	1.58	0.12	1.97	8.8	RACL202
19.03	10.80	14.73	3.35	2.48	2.17	1.07	1.58	0.12	1.97	10.1	RACL204
28.55	12.76	18.67	3.35	2.48	2.17	1.07	1.58	0.12	1.97	11.4	RACL206
38.01	14.73	22.61	3.35	2.48	2.17	1.07	1.58	0.12	1.97	12.7	RACL208
47.53	16.70	26.54	3.35	2.48	2.17	1.07	1.58	0.12	1.97	14.1	RACL2010
13.49	9.10	11.07	3.94	2.95	2.36	1.31	1.58	0.12	1.97	11.9	RACL302
26.99	11.07	15.01	3.94	2.95	2.36	1.31	1.58	0.12	1.97	13.4	RACL304
40.48	13.04	18.95	3.94	2.95	2.36	1.31	1.58	0.12	1.97	14.9	RACL306
53.91	15.01	22.88	3.94	2.95	2.36	1.31	1.58	0.12	1.97	16.5	RACL308
67.40	16.98	26.82	3.94	2.95	2.36	1.31	1.58	0.12	1.97	18.0	RACL3010
21.65	9.29	11.27	5.12	3.74	3.15	1.19	1.97	0.12	2.95	20.5	RACL502
43.30	11.26	15.21	5.12	3.74	3.15	1.19	1.97	0.12	2.95	23.4	RACL504
64.95	13.23	19.14	5.12	3.74	3.15	1.19	1.97	0.12	2.95	27.8	RACL506
86.49	15.20	23.08	5.12	3.74	3.15	1.19	1.97	0.12	2.95	29.1	RACL508
108.14	17.17	27.02	5.12	3.74	3.15	1.19	1.97	0.12	2.95	31.9	RACL5010
43.71	11.65	13.63	7.09	5.32	4.33	1.82	3.70	0.12	2.95	48.2	RACL1002
87.43	13.62	17.57	7.09	5.32	4.33	1.82	3.70	0.12	2.95	53.3	RACL1004
131.14	15.59	21.50	7.09	5.32	4.33	1.82	3.70	0.12	2.95	58.4	RACL1006
174.64	17.57	25.44	7.09	5.32	4.33	1.82	3.70	0.12	2.95	63.4	RACL1008
218.35	19.54	29.38	7.09	5.32	4.33	1.82	3.70	0.12	2.95	68.5	RACL10010
69.30	12.72	14.68	9.06	6.69	5.51	2.02	4.45	0.12	3.15	71.0	RACL1502
138.61	14.69	18.62	9.06	6.69	5.51	2.02	4.45	0.12	3.15	79.8	RACL1504
207.91	16.65	22.56	9.06	6.69	5.51	2.02	4.45	0.12	3.15	88.6	RACL1506
276.87	18.62	26.49	9.06	6.69	5.51	2.02	4.45	0.12	3.15	97.4	RACL1508
346.17	20.59	30.43	9.06	6.69	5.51	2.02	4.45	0.12	3.15	106.3	RACL15010

▼ Shown from left to right: RACH1508, RACH304 and RACH208



The Lightweight Solution for Tensioning and Testing



Saddles

All RACH-cylinders are equipped with bolt-on removable hardened steel hollow saddles.



Lightweight Hand Pumps

Enerpac hand pumps **P392** or **P802** make the optimal lightweight set.

Page: 86

- Hollow plunger design allows for both pull and push forces
- Composite bearings increase cylinder life and side load resistance
- Hard coat finish on all surfaces resists damage and extends cylinder life
- Handles included on all models
- Floating center tube increases seal life
- Steel baseplate and saddle for protection against load-induced damage
- Integral stop-ring prevents plunger over-travel and is capable of withstanding the full cylinder capacity
- High-strength return spring for rapid cylinder retraction
- CR400 coupler and dust cap included on all models
- All cylinders meet ASME B-30.1 standards



◀ An RACH306, powered by a P392 hand pump, is used to extract corroded carriage pins from refuse collection vehicles.

Cylinder Capacity tons (maximum)	Stroke* (in)	Model Number	Cylinder Effective Area (in ²)
20 (25.4)	1.97	RACH202	5.07
	3.94	RACH204	5.07
	5.91	RACH206	5.07
	7.87	RACH208	5.07
	9.84	RACH2010	5.07
30 (39.6)	1.97	RACH302	7.92
	3.94	RACH304	7.92
	5.91	RACH306	7.92
	7.87	RACH308	7.92
	9.84	RACH3010	7.92
60 (65.6)	1.97	RACH602	13.13
	3.94	RACH604	13.13
	5.91	RACH606	13.13
	7.87	RACH608	13.13
	9.84	RACH6010	13.13
100 (127.5)	1.97	RACH1002	25.51
	3.94	RACH1004	25.51
	5.91	RACH1006	25.51
	7.87	RACH1008	25.51
	9.84	RACH10010	25.51
150 (175.0)	1.97	RACH1502	35.00
	3.94	RACH1504	35.00
	5.91	RACH1506	35.00
	7.87	RACH1508	35.00
	9.84	RACH15010	35.00

* Custom strokes available.

Single-Acting, Spring-Return, Hollow Plunger Cylinders



Steel Base Plate

The steel base plate protects the cylinder base from damage, it should not be removed.

The base holes in these aluminum cylinders are designed for securing the steel base plate.

They will not withstand the capacity of the cylinder.

Do not use the base holes in these aluminum cylinders to attach any device to the cylinder.

RACH Series

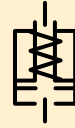

Capacity:

20 - 150 tons

Stroke:

1.97 - 9.84 inches

Center Hole Diameter:

1.06 - 3.11 inches

Maximum Operating Pressure:

10,000 psi

Steel Base Plate Mounting Holes

Cylinder Model / Capacity (ton)	Bolt Circle U (in)	Thread V (mm)	Thread Depth ¹⁾ Z (in)
RACH20	3.15	M6	0.47
RACH30	4.33	M6	0.47
RACH60	6.30	M6	0.47
RACH100	8.66	M10	0.47
RACH150	9.65	M10	0.47

¹⁾ Including Base Plate Height of 0.25 inches. Four (4) baseplate bolts included.

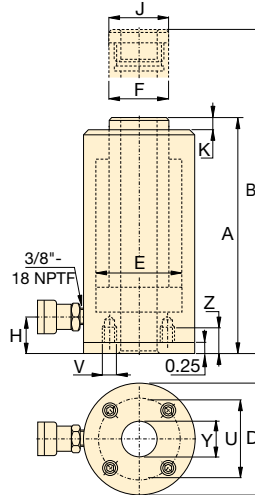

Oil Capacity (in ³)	Collapsed Height A (in)	Extended Height B (in)	Outside Diameter D (in)	Cylinder Bore Diameter E (in)	Plunger Diameter F (in)	Base to Advance Port G (in)	Saddle Diameter H (in)	Saddle Protrusion from Plunger I (in)	Center Hole Diameter J (in)	Weight (lbs)	Model Number
9.98	7.41	9.38	3.93	2.95	2.17	1.14	2.17	0.40	1.06	11.5	RACH202
19.96	9.89	13.83	3.93	2.95	2.17	1.14	2.17	0.40	1.06	13.5	RACH204
29.94	12.41	18.32	3.93	2.95	2.17	1.14	2.17	0.40	1.06	15.6	RACH206
39.87	14.89	22.76	3.93	2.95	2.17	1.14	2.17	0.40	1.06	17.7	RACH208
49.90	17.41	27.25	3.93	2.95	2.17	1.14	2.17	0.40	1.06	19.8	RACH2010
15.59	8.20	10.17	5.12	3.74	2.76	1.14	2.76	0.40	1.34	17.6	RACH302
31.18	10.52	14.46	5.12	3.74	2.76	1.14	2.76	0.40	1.34	20.9	RACH304
46.77	13.12	19.02	5.12	3.74	2.76	1.14	2.76	0.40	1.34	24.6	RACH306
62.35	15.56	23.43	5.12	3.74	2.76	1.14	2.76	0.40	1.34	28.4	RACH308
77.94	18.04	27.88	5.12	3.74	2.76	1.14	2.76	0.40	1.34	31.9	RACH3010
25.84	9.89	11.86	7.09	5.12	3.94	2.41	3.94	0.47	2.13	35.6	RACH602
51.69	12.41	16.35	7.09	5.12	3.94	2.41	3.94	0.47	2.13	42.8	RACH604
77.53	14.97	20.87	7.09	5.12	3.94	2.41	3.94	0.47	2.13	50.3	RACH606
103.37	17.52	25.40	7.09	5.12	3.94	2.41	3.94	0.47	2.13	57.2	RACH608
129.21	20.09	29.93	7.09	5.12	3.94	2.41	3.94	0.47	2.13	65.1	RACH6010
50.21	10.16	12.13	9.84	7.28	5.71	2.41	5.71	0.55	3.11	74.6	RACH1002
100.43	12.80	16.74	9.84	7.28	5.71	2.41	5.71	0.55	3.11	87.8	RACH1004
150.64	15.40	21.31	9.84	7.28	5.71	2.41	5.71	0.55	3.11	101.9	RACH1006
200.85	18.08	25.95	9.84	7.28	5.71	2.41	5.71	0.55	3.11	115.7	RACH1008
251.07	20.76	30.60	9.84	7.28	5.71	2.41	5.71	0.55	3.11	129.3	RACH10010
66.08	11.03	13.00	10.83	8.07	5.91	2.41	5.71	0.55	3.11	107.7	RACH1502
132.17	14.18	18.12	10.83	8.07	5.91	2.41	5.71	0.55	3.11	122.8	RACH1504
206.72	16.93	22.84	10.83	8.07	5.91	2.41	5.71	0.55	3.11	138.9	RACH1506
275.62	19.69	27.57	10.83	8.07	5.91	2.41	5.71	0.55	3.11	154.5	RACH1508
344.53	22.45	32.29	10.83	8.07	5.91	2.41	5.71	0.55	3.11	170.2	RACH15010

▼ Shown from left to right: RARH6010 and RARH306



The Lightweight Solution for Double-Acting Applications

- Lighter and shorter collapsed height than equivalent RACH single-acting models
- Double-acting for rapid retraction, regardless of hose lengths or system losses
- Built-in safety valve prevents accidental over pressurization
- Hollow plunger design allows for both pull and push forces
- Composite bearings increase cylinder life and side load resistance
- Hard coat finish on all surfaces resists damage and extends cylinder life
- Handles included on all models
- Floating center tube increases seal life
- Steel baseplate and saddle for protection against load-induced damage
- Integral stop-ring prevents plunger over-travel and is capable of withstanding the full cylinder capacity
- All cylinders meet ASME B-30.1 standards



Hoses
Enerpac offers a complete line of high-quality hydraulic hoses. To ensure the integrity of your system, specify only Enerpac hydraulic hoses.

Page: 148



Gauges
Minimize the risk of overloading and ensure long, dependable service from your equipment. Refer to the System Components section for a full range of gauges.

Page: 147



4-Way Control Valve
P84 and P464 pumps feature a manual 4-way control valve, designed for use with one double-acting or two single-acting cylinders. For system set-up information:

Page: 164

Cylinder Capacity (ton)	Stroke* (in)	Model Number	Maximum Cylinder Capacity @ 10,150 psi (ton)		Cylinder Effective Area (in ²)		Oil Capacity (in ³)	
			Advance	Retract	Advance	Retract	Advance	Retract
30	1.97	RARH302	40.30	21.00	7.94	4.14	15.63	8.14
	5.91	RARH306	40.30	21.00	7.94	4.14	46.89	24.43
	9.84	RARH3010	40.30	21.00	7.94	4.14	78.15	40.72
60	1.97	RARH602	66.81	29.65	13.17	5.84	25.91	11.50
	5.91	RARH606	66.81	29.65	13.17	5.84	77.72	34.50
	9.84	RARH6010	66.81	29.65	13.17	5.84	129.54	57.49
100	1.97	RARH1002	112.40	63.80	22.16	12.57	43.60	24.73
	5.91	RARH1006	112.40	63.80	22.16	12.57	130.79	74.19
	9.84	RARH10010	112.40	63.80	22.16	12.57	217.99	123.66
150	1.97	RARH1502	167.20	84.00	32.96	16.56	64.86	32.58
	5.91	RARH1506	167.20	84.00	32.96	16.56	194.57	97.74
	9.84	RARH15010	167.20	84.00	32.96	16.56	324.28	162.89

* Intermediate strokes and other tonnages available upon request

Aluminium Double-Acting Hollow Plunger Cylinders



Steel Base Plate

The steel base plate protects the cylinder base from damage, it should not be removed.

The base holes in these aluminum cylinders are designed for securing

the steel base plate. **They will not withstand the capacity of the cylinder.**

Do not use the base holes in these aluminum cylinders to attach any device to the cylinder.

Optional Threaded Hollow Saddles

Saddle Type	Cylinder Model Number	Saddle Model No.	Saddle Dimensions (in)		
			A	B	C
Threaded Hollow	RARH302, 306, 3010	HP3015	2.49	1¼"-7	0.38
	RARH602, 606, 6010	HP5016	3.61	1½"-5½	0.50
	RARH1002, 1006, 10010	HP10016	4.96	2½"-8 UN	0.51

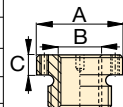

Smooth hollow saddles are standard on all RARH-models.

Steel Base Plate Mounting Holes

Cylinder Model / Capacity (ton)	Bolt Circle U (in)	Thread V (mm)	Thread Depth ¹⁾ Z (in)
RARH30	4.33	M6	0.47
RARH60	6.30	M6	0.47
RARH100	7.87	M10	0.47
RARH150	9.84	M10	0.47

¹⁾ Including Base Plate Height of 0.25 inches. Four (4) base plate bolts included.

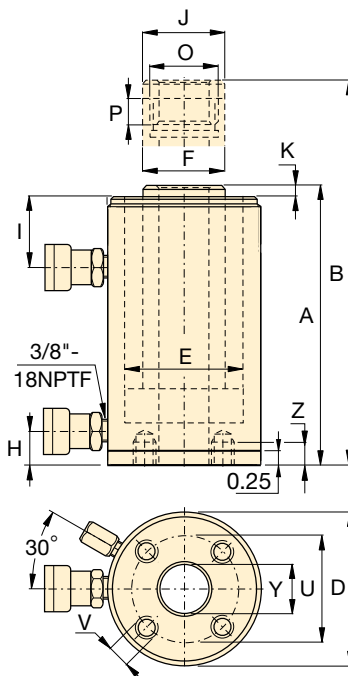

RARH Series



Capacity:

30 - 150 ton

Stroke:

2 - 10 inches

Center Hole Diameter:

1.34 - 3.11 inches

Maximum Operating Pressure:

10,150 psi



RACH-Series, Single-Acting, Spring-Return

To be used when a single-acting pump is available and retraction time is not critical.

Page: 16



Pump Selection

A double-acting cylinder must be powered by a pump with a 4-way valve.

Page: 139

Collap. Height	Ext. Height	Outside Diam.	Cyl. Bore Diam.	Plng. Diam.	Cyl. Base to Advance Port	Cyl. Top to Return Port	Saddle Diameter	Saddle Protrusion from Plunger	Plunger Internal Thread	Plunger Thread Length	Center Hole Diameter	Weight	Model Number
A (in)	B (in)	D (in)	E (in)	F (in)	H (in)	I (in)	J (in)	K (in)	O (in)	P (in)	Y (in)	(lbs)	
8.22	10.19	5.31	3.74	2.95	0.86	2.53	2.49	0.38	1 ¹³ / ₁₆ "-16 UN	0.91	1.34	19.6	RARH302
12.16	18.07	5.31	3.74	2.95	0.86	2.53	2.49	0.38	1 ¹³ / ₁₆ "-16 UN	0.91	1.34	26.2	RARH306
16.10	25.94	5.31	3.74	2.95	0.86	2.53	2.49	0.38	1 ¹³ / ₁₆ "-16 UN	0.91	1.34	32.8	RARH3010
9.68	11.65	7.09	5.12	4.33	1.88	3.28	3.61	0.50	2 ³ / ₄ "-16 UN	0.79	2.13	37.0	RARH602
13.62	19.52	7.09	5.12	4.33	1.88	3.28	3.61	0.50	2 ³ / ₄ "-16 UN	0.79	2.13	48.8	RARH606
17.56	27.40	7.09	5.12	4.33	1.88	3.28	3.61	0.50	2 ³ / ₄ "-16 UN	0.79	2.13	60.7	RARH6010
9.99	11.96	9.25	6.50	5.12	2.41	3.07	4.97	0.53	4"-16 UN	1.06	3.11	63.6	RARH1002
13.92	19.83	9.25	6.50	5.12	2.41	3.07	4.97	0.53	4"-16 UN	1.06	3.11	84.3	RARH1006
17.86	27.70	9.25	6.50	5.12	2.41	3.07	4.97	0.53	4"-16 UN	1.06	3.11	104.9	RARH10010
10.39	12.36	11.02	7.48	5.91	2.41	3.27	5.00	0.74	4 ¹ / ₄ "-12 UN	1.57	3.11	93.3	RARH1502
14.33	20.24	11.02	7.48	5.91	2.41	3.27	5.00	0.74	4 ¹ / ₄ "-12 UN	1.57	3.11	123.6	RARH1506
18.27	28.11	11.02	7.48	5.91	2.41	3.27	5.00	0.74	4 ¹ / ₄ "-12 UN	1.57	3.11	154.0	RARH15010

▼ Shown from left to right: RAR506, RAR508, RAR302



The Lightweight Solution for Double-Acting Applications



Saddles

All RAR-cylinders are equipped with bolt-on removable hardened steel saddles. For tilt saddles see next page.

Page: 21



Hoses

Enerpac offers a complete line of high-quality hydraulic hoses. To ensure the integrity of your system, specify only Enerpac hydraulic hoses.

Page: 148

- Double-acting for rapid retraction, regardless of hose lengths and system losses
- Composite bearings increase cylinder life and side load resistance
- Hard coat finish on all surfaces resists damage and extends cylinder life
- Handles included on all models
- Steel base plate and saddle for protection against load-induced damage
- Integral stop-ring prevents plunger over-travel and is capable of withstanding the full cylinder capacity
- Built-in safety valve prevents accidental over-pressurization



◀ An RAR506 was easy to position under a bulldozer for repair of frame member.

Cylinder Capacity (ton)	Stroke* (in)	Model Number	Maximum Cylinder Capacity	Cylinder Effective Area		Oil Capacity	
			(ton)	(in ²)		(in ³)	
			Push	Push	Pull	Push	Pull
20 (24.2)	1.97	RAR202	24.2	4.83	2.88	9.52	5.67
	3.94	RAR204	24.2	4.83	2.88	19.03	11.34
	5.91	RAR206	24.2	4.83	2.88	28.55	17.02
	7.87	RAR208	24.2	4.83	2.88	38.01	22.66
	9.84	RAR2010	24.2	4.83	2.88	47.53	28.34
30 (34.2)	1.97	RAR302	34.2	6.85	3.80	13.49	7.49
	3.94	RAR304	34.2	6.85	3.80	26.99	14.97
	5.91	RAR306	34.2	6.85	3.80	40.48	22.46
	7.87	RAR308	34.2	6.85	3.80	53.91	29.91
	9.84	RAR3010	34.2	6.85	3.80	67.40	37.39
50 (54.9)	1.97	RAR502	55	10.99	3.54	21.65	6.97
	3.94	RAR504	55	10.99	3.54	43.30	13.95
	5.91	RAR506	55	10.99	3.54	64.95	20.92
	7.87	RAR508	55	10.99	3.54	86.49	27.86
	9.84	RAR5010	55	10.99	3.54	108.14	34.83
100 (110.9)	1.97	RAR1002	111	22.19	12.33	43.71	24.29
	3.94	RAR1004	111	22.19	12.33	87.43	48.58
	5.91	RAR1006	111	22.19	12.33	131.14	72.87
	7.87	RAR1008	111	22.19	12.33	174.64	97.04
	9.84	RAR10010	111	22.19	12.33	218.35	121.33
150 (175.9)	1.97	RAR1502	176	35.18	20.45	69.30	40.29
	3.94	RAR1504	176	35.18	20.45	138.61	80.57
	5.91	RAR1506	176	35.18	20.45	207.91	120.86
	7.87	RAR1508	176	35.18	20.45	276.87	160.94
	9.84	RAR15010	176	35.18	20.45	346.17	201.23

* Custom strokes available.

Double-Acting, Aluminum Cylinders

Optional Tilt Saddle Dimensions (in)			
Cylinder Model / Capacity (ton)	Tilt Saddle Model Number	Tilt Saddle Diameter	Addition to Collapsed Height A1
		J1	A1
RAR20	CATS20	1.65	0.39
RAR30	CATS30	2.17	0.43
RAR50	CATS50	2.80	0.55
RAR100	CATS101	2.80	0.39
RAR150	CATS150	4.96	0.71

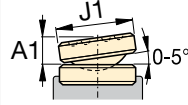

Steel Base Plate Mounting Holes			
Cylinder Model / Capacity (ton)	Bolt Circle U (in)	Thread V (mm)	Thread Depth ¹⁾ Z (in)
RAR20	3.66	M6	0.47
RAR30	4.13	M6	0.47
RAR50	4.33	M6	0.47
RAR100	6.10	M10	0.47
RAR150	7.87	M10	0.47

¹⁾ Including Base Plate Height of 0.25 inches. Four (4) base plate bolts included.

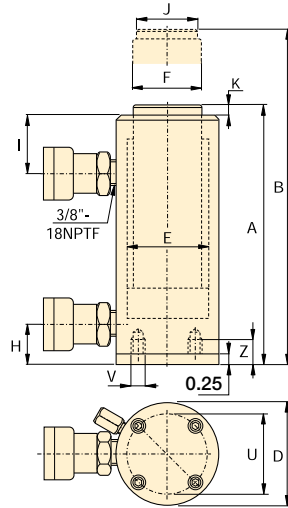

RAR Series



Capacity:
20 - 150 tons

Stroke:
1.97 - 9.84 inches

Maximum Operating Pressure:
10,000 psi



Steel Base Plate

The steel base plate protects the cylinder base from damage, it should not be removed. See warning on page 11.

Page: **11**

Collapsed Height	Extended Height	Outside Diameter	Cylinder Bore Diameter	Plunger Diameter	Base to Advance Port	Top to Retract Port	Saddle Diameter	Saddle Protrusion from Plunger	Weight	Model Number
A (in)	B (in)	D (in)	E (in)	F (in)	H (in)	I (in)	J (in)	K (in)	(lbs)	
7.45	9.42	4.45	2.48	1.58	1.19	1.97	1.18	0.12	16.3	RAR202
9.42	13.35	4.45	2.48	1.58	1.19	1.97	1.18	0.12	17.6	RAR204
11.29	17.29	4.45	2.48	1.58	1.19	1.97	1.18	0.12	19.0	RAR206
13.35	21.23	4.45	2.48	1.58	1.19	1.97	1.18	0.12	20.3	RAR208
15.32	25.17	4.45	2.48	1.58	1.19	1.97	1.18	0.12	21.6	RAR2010
7.92	9.89	4.92	2.95	1.97	1.19	2.17	1.58	0.12	19.0	RAR302
9.89	13.83	4.92	2.95	1.97	1.19	2.17	1.58	0.12	20.9	RAR304
11.86	17.76	4.92	2.95	1.97	1.19	2.17	1.58	0.12	22.9	RAR306
13.83	21.70	4.92	2.95	1.97	1.19	2.17	1.58	0.12	24.9	RAR308
15.80	25.64	4.92	2.95	1.97	1.19	2.17	1.58	0.12	26.9	RAR3010
7.92	9.89	5.71	3.74	2.95	1.19	2.21	1.97	0.12	24.5	RAR502
9.89	13.83	5.71	3.74	2.95	1.19	2.21	1.97	0.12	28.0	RAR504
11.86	17.76	5.71	3.74	2.95	1.19	2.21	1.97	0.12	31.5	RAR506
13.83	21.70	5.71	3.74	2.95	1.19	2.21	1.97	0.12	35.1	RAR508
15.80	25.64	5.71	3.74	2.95	1.19	2.21	1.97	0.12	38.6	RAR5010
9.89	11.86	7.28	5.32	3.54	1.70	3.15	2.95	0.12	36.2	RAR1002
11.86	15.80	7.28	5.32	3.54	1.70	3.15	2.95	0.12	42.6	RAR1004
13.83	19.73	7.28	5.32	3.54	1.70	3.15	2.95	0.12	48.9	RAR1006
15.80	23.67	7.28	5.32	3.54	1.70	3.15	2.95	0.12	55.3	RAR1008
17.76	27.61	7.28	5.32	3.54	1.70	3.15	2.95	0.12	61.7	RAR10010
9.77	11.74	9.06	6.70	4.33	1.50	2.95	3.70	0.12	53.4	RAR1502
11.74	16.68	9.06	6.70	4.33	1.50	2.95	3.70	0.12	63.7	RAR1504
13.71	19.61	9.06	6.70	4.33	1.50	2.95	3.70	0.12	73.2	RAR1506
15.68	23.55	9.06	6.70	4.33	1.50	2.95	3.70	0.12	83.6	RAR1508
17.64	29.46	9.06	6.70	4.33	1.50	2.95	3.70	0.12	93.9	RAR15010

CULP-Series, Ultra-Flat Cylinders with Stop-Ring **ENERPAC**

▼ CULP50 Ultra-Flat Cylinder, with Stop-Ring



- Up to 4% side load of maximum capacity
- Stop-ring for maximum stroke limitation
- Extremely low collapsed height
- Nitrocarburized surface treatment for harsh conditions

▼ The Ultra-Flat cylinders are designed for applications where high lifting forces are required in confined spaces starting at 1.10 inch (CUSP200 is shown).

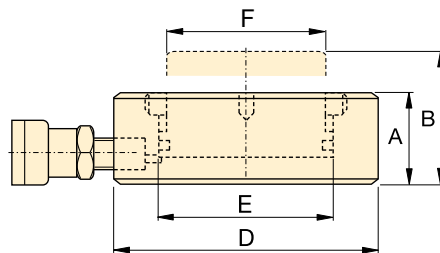

CULP Series



Capacity:

10 - 100 tons

Stroke:

0.24 inches

Maximum Operating Pressure:

10,150 psi



IMPORTANT!

All Ultra-Flat Cylinders require a solid lifting surface for correct support.

The use of these flat cylinders on surfaces such as sand, mud or dirt, may result in cylinder damage.

INCORRECT!

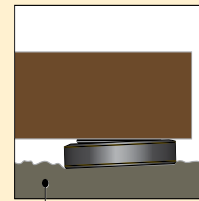

Rough soil

CORRECT!

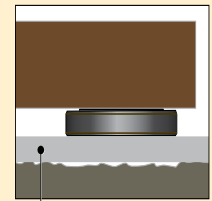

Flat lifting surface

For more safety instructions see our Yellow Pages.



Hoses

Enerpac offers a complete line of high-quality hydraulic hoses. To ensure the integrity of your system, specify only genuine Enerpac hydraulic hoses.

Page: 148

Cylinder Capacity @ 10,150 psi ton (max.)	Stroke (in)	Model Number	Cylinder Effective Area (in ²)	Oil Capacity (in ³)	Collapsed Height A (in)	Extended Height B (in)	Outside Diameter D (in)	Cylinder Bore Diameter E (in)	Plunger Diameter F (in)	Weight (lbs)
10 (10.9)	0.24	CULP10 ¹⁾	2.15	0.51	1.08	1.32	2.83	1.65	1.49	2
20 (22.2)	0.24	CULP20 ¹⁾	4.38	1.04	1.26	1.50	3.54	2.36	2.16	4
30 (34.8)	0.24	CULP30 ¹⁾	6.85	1.62	1.38	1.61	4.13	2.95	2.64	6
50 (61.8)	0.24	CULP50 ¹⁾	12.17	2.88	1.75	1.99	5.51	3.94	3.54	11.9
100 (121.1)	0.24	CULP100 ²⁾	23.85	5.63	2.55	2.79	7.67	5.51	4.92	25.3

¹⁾ Coupler AR630 including dustcap: Use HB7206 hose including AH630 coupler to connect to your pump.

²⁾ Coupler CR400 including dustcap: Use HC-Series hose including CH604 coupler to connect to your pump.

CUSP-Series, High-Tonnage, Ultra-Flat Cylinders

▼ CUSP-Series, Ultra-Flat, High-Tonnage Cylinders, integrated tilting function



- Up to 4% side load of maximum capacity
- Extremely low collapsed height
- Integrated tilting function up to 4 degrees to evenly distribute the load
- Nitrocarburized surface treatment for harsh conditions
- “Red Line” for visual maximum stroke indication

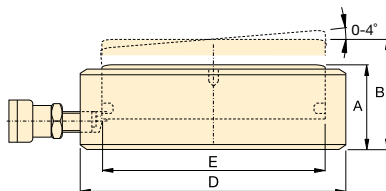

CUSP Series



Capacity:

10 - 1000 tons

Tilted Stroke / Straight Stroke:

0.24-0.39"/0.26-0.69"

Integrated:

Tilting Function

Maximum Operating Pressure:

10,150 psi



IMPORTANT!

CUSP Cylinders DO NOT have a stop-ring for stroke limitation!



IMPORTANT!

All Ultra-Flat Cylinders require a solid lifting surface for correct support. The use of these flat cylinders on surfaces such as sand, mud or dirt, may result in cylinder damage.

Page: 400

Cylinder Capacity @ 10,150 psi ton (max.)	Tilted Stroke (in)	Straight Stroke (in)	Model Number	Tilting +/- (degrees)	Cylinder Effective Area (in ²)	Oil Capacity (in ³)	Collapsed Height A (in)	Extended Height B (in)	Outside Diameter D (in)	Cylinder Bore Diameter E (in)	Wt. (lbs)
10 (10.9)	0.24	0.26	CUSP10 ¹⁾	2	2.15	0.57	1.40	1.66	2.83	1.65	2.6
20 (22.2)	0.24	0.28	CUSP20 ¹⁾	2	4.39	1.21	1.59	1.87	3.54	2.36	4.2
30 (34.8)	0.24	0.29	CUSP30 ¹⁾	2	6.85	1.97	1.67	1.96	4.13	2.95	6.0
50 (61.8)	0.39	0.52	CUSP50 ¹⁾	4	12.17	6.37	2.24	2.77	5.12	3.94	12.3
75 (89.0)	0.39	0.55	CUSP75 ¹⁾	4	17.53	9.66	2.38	2.93	5.91	4.72	17.6
100 (121.1)	0.39	0.58	CUSP100 ²⁾	4	23.85	13.81	2.50	3.08	6.69	5.51	23.8
150 (178.6)	0.39	0.56	CUSP150 ²⁾	3	35.19	19.81	2.56	3.12	7.87	6.69	33.7
200 (235.0)	0.39	0.59	CUSP200 ²⁾	3	46.28	27.15	2.72	3.30	9.02	7.68	47.4
250 (285.6)	0.39	0.61	CUSP250 ²⁾	3	56.28	34.34	2.85	3.46	9.92	8.46	60.2
300 (355.9)	0.39	0.56	CUSP300 ²⁾	2	70.12	38.93	2.85	3.41	11.10	9.45	75.8
400 (450.5)	0.39	0.57	CUSP400 ²⁾	2	88.75	51.01	3.05	3.63	12.44	10.63	101.9
500 (574.8)	0.39	0.60	CUSP500 ²⁾	2	113.24	67.77	3.25	3.85	14.02	12.01	138.2
600 (672.9)	0.39	0.61	CUSP600 ²⁾	2	132.57	81.42	3.44	4.06	15.20	12.99	172.8
750 (846.0)	0.39	0.64	CUSP750 ²⁾	2	166.66	106.95	3.68	4.32	17.01	14.57	231.9
1000(1142.6)	0.39	0.69	CUSP1000 ²⁾	2	225.09	154.20	4.06	4.74	19.76	16.93	346.1

¹⁾ Coupler AR630 including dustcap: Use HB7206 hose including AH630 coupler to connect to your pump.

²⁾ Coupler CR400 including dustcap: Use HC-Series hose including CH604 coupler to connect to your pump.

▼ LPL-Series, Low-height Lock Nut Cylinders



The Lowest Power Lifter



Integrated Tilt Saddles

All LPL-Series cylinders include integrated tilt saddles with maximum tilt angles up to 5°.

- Lock nut provides mechanical load holding for a safe work environment
- Integrated tilt saddle allows for up to 5 degrees of misalignment
- Extreme low-height for use in confined areas
- Side-load resistance 5-10% of maximum capacity
- Overflow port as stroke limiter to prevent plunger blow-out
- Single-acting, load-return

▼ Only the extreme low-height LPL-cylinder fits in this confined area to lift the construction. The lock nut provides positive and safe mechanical load holding over a long period of time.



Cylinder Capacity (ton)	Stroke (in)	Model Number	Maximum Cylinder Cap. at 10,150 psi (ton)	Side-load Resistance of Maximum Capacity	Cylinder Effective Area (in ²)
60	1.97	LPL602	68	10%	13.42
100	1.97	LPL1002	113	10%	22.19
150	1.77	LPL1602	179	8%	35.18
200	1.77	LPL2002	223	8%	43.95
250	1.77	LPL2502	286	5%	56.27
400	1.77	LPL4002	450	5%	88.75
500	1.77	LPL5002	575	5%	113.25

Single Acting, Low-Height Lock Nut Cylinders



IMPORTANT!

All LPL-Series cylinders require a solid lifting surface for correct support. The use of these cylinders on surfaces such as sand, mud or dirt, may result in cylinder damage.

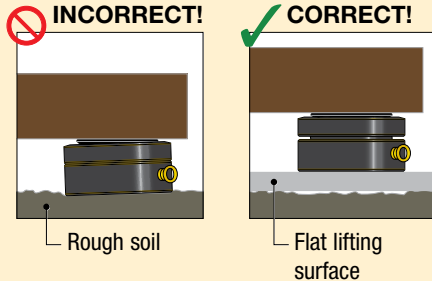

For more safety instructions see our 'Learning Center' on www.enerpac.com

LPL Series



Capacity:

60 - 500 ton

Stroke:

1.77 - 1.97 inches

Maximum Operating Pressure:

10,150 psi



Longer Stroke Lock Nut Cylinders

For longer stroke applications HCL-Series Lock Nut Cylinders are the perfect choice.

Page: **56**



Split-Flow Pumps

SFP-Series pumps with multiple outlets with equal oil flow. For lifting and lowering applications on multiple points these pumps are a far better alternative than using separately operated pumps.

Page: **132**



Synchronous Lifting Systems

Pumps for multiple lift-point capabilities. When increased stroke accuracy is required, use the multi-functional EVO-Series lifting system.

Page: **136**

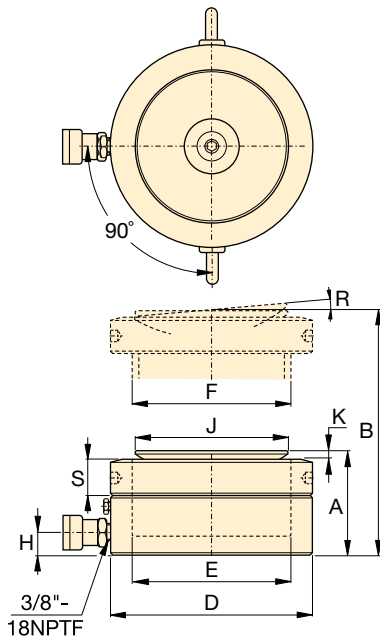

Oil Capacity	Collapsed Height	Extended Height	Outside Diameter	Cylinder Bore Diameter	Plunger Diameter	Base to Advance Port	Saddle Diameter	Saddle Protrusion from Plunger	Saddle Max. Tilt Angle	Lock Nut Height	Wt.	Model Number
(in ³)	A (in)	B (in)	D (in)	E (in)	F (mm)	H (in)	J (in)	K (in)	R (degrees)	S (in)	(lbs)	
26.4	4.94	6.91	5.51	4.13	Tr 105 x 4	0.75	3.78	0.26	5°	1.10	33	LPL602
43.7	5.39	7.36	6.81	5.31	Tr 135 x 6	0.83	4.96	0.31	5°	1.22	54	LPL1002
62.3	5.83	7.60	8.66	6.69	Tr 170 x 6	1.06	6.30	0.35	5°	1.57	94	LPL1602
77.9	6.10	7.87	9.65	7.48	Tr 190 x 6	1.18	7.09	0.39	5°	1.69	121	LPL2002
99.7	6.24	8.01	10.83	8.46	Tr 215 x 6	1.26	7.87	0.45	5°	1.69	155	LPL2502
157.2	7.01	8.78	13.78	10.63	Tr 270 x 6	1.56	9.84	0.45	4°	2.17	284	LPL4002
200.6	7.56	9.33	15.75	12.01	Tr 305 x 6	1.91	11.42	0.39	3°	2.42	404	LPL5002

▼ Shown from left to right: RSM1000, RSM300, RSM50, RCS1002, RCS302



Maximum Power to Height Ratio



Saddles

All **RCS-Series** cylinders have plunger mounting holes for installation of tilt saddles. See table for selection and dimensional information.

Page: 27



Low Clearance Lifting

The **LW16** Lifting Wedge and **SOH-Series** Machine Lifts are the perfect choices for lifting loads that have low clearance.

Page: 212

RSM-Series, Flat-Jac® Cylinders

- Compact, flat design for use where other cylinders will not fit
- RSM750, 1000 and 1500 have handles for easy carrying
- Mounting holes permit easy fixturing
- Baked enamel finish for increased corrosion resistance
- CR400 coupler and dust cap included on all models¹⁾
- Hard chrome plated high-quality steel plungers
- Grooved plunger ends require no saddle
- Single-acting spring-return

RCS-Series, Low-Height Cylinders

- Lightweight, low profile design for use in confined spaces
- Baked enamel finish for increased corrosion resistance
- Plunger wiper reduces contamination, extending cylinder life
- CR400 coupler and dust cap included on all models
- Grooved plunger end with threaded holes for mounting tilt saddles
- Integral handle on RCS1002 for easy carrying
- Plated steel plungers
- Single-acting spring-return

▼ Only a couple of inches are needed for an RSM-cylinder to lift this large steel construction.



Cylinder Capacity (tons) [max.]	Stroke (in)	Model Number	Cyl. Effect. Area (in ²)	Oil Cap. (in ³)
5 [4.9]	0.25	RSM50 ¹⁾	0.99	0.25
10 [11.2]	0.44	RSM100	2.24	0.98
20 [22.1]	0.44	RSM200	4.43	1.94
30 [32.4]	0.50	RSM300	6.49	3.25
50 [48.1]	0.63	RSM500	9.62	6.01
75 [79.5]	0.63	RSM750	15.90	9.94
100 [98.1]	0.63	RSM1000	19.63	12.27
150 [153.4]	0.63	RSM1500	30.68	19.17
10 [11.2]	1.50	RCS101*	2.24	3.35
20 [22.1]	1.75	RCS201*	4.43	7.75
30 [32.4]	2.44	RCS302*	6.49	15.82
50 [48.1]	2.38	RCS502*	9.62	22.85
100 [98.1]	2.25	RCS1002*	19.63	44.18

¹⁾ RSM50 is fitted with an AR400 coupler.

* Available as a set. See note on next page.

Single-Acting, Low-Height Cylinders

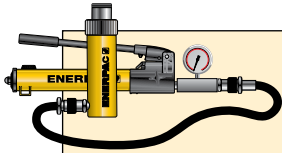

Pump and Cylinder Sets

All cylinders marked with an ** are available as sets (cylinder, gauge, couplers, hose and pump) for your ordering convenience.

Page: 62

Optional Tilt Saddle Dimensions (in)

For Cylinder Model /Capacity (ton)	Tilt Saddle Model Number	Tilt Saddle Diameter J1	Addition to Collapsed Height A1
RCS101	CATS13	1.38	0.79
RCS201	CATS53	1.97	1.02
RCS302	CATS53	1.97	1.02
RCS502	CATS53	1.97	1.02
RCS1002	CATS103	2.80	1.38

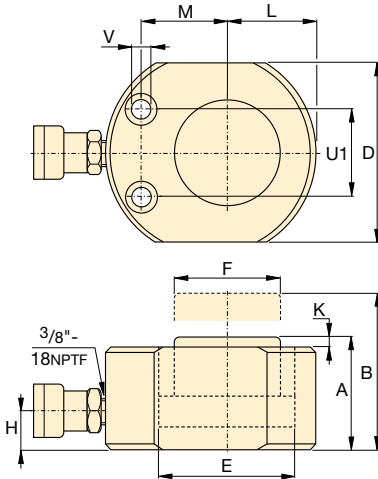
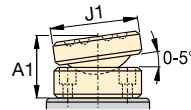

RSM-Series

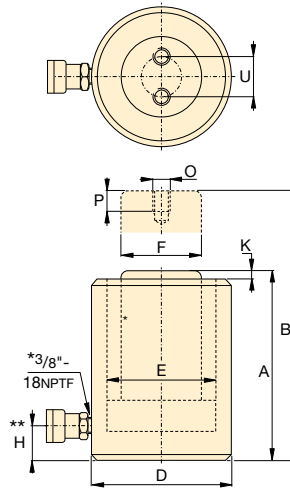

RCS-Series**

** 5° angle position of coupler on RCS101, 201, 302.

RSM RCS Series



Capacity:

5 - 150 tons

Stroke:

0.25 - 2.44 inches

Maximum Operating Pressure:

10,000 psi



Portable Hydraulic Tool Box

Tool box with hand pump, gauge adaptor assembly, hose and choice of RC, RSM or RCS cylinder.

Page: 65

RSM Cylinder Mounting Hole Dimensions (in)

Model Number	Hole Pitch U1	Hole Diam. V	Counter Bore Diam.	Counter Bore Depth
RSM50	1.12	0.20	0.312	0.17
RSM100	1.44	0.28	0.422	0.31
RSM200	1.94	0.40	0.594	0.39
RSM300	2.06	0.40	0.625	0.44
RSM500	2.62	0.47	0.750	0.50
RSM750	3.00	0.53	0.812	0.56
RSM1000	3.00	0.53	0.812	0.56
RSM1500	4.62	0.53	0.812	0.56

Collapsed Height	Extended Height	Outside Diameter	Cylinder Bore Diameter	Plunger Diameter	Base to Advance Port	Collapsed Height**	Plunger to Base	Plunger to Mtg. Hole	Thread	Thread Depth	Bolt Circle	Weight	Model Number
A (in)	B (in)	D (in)	E (in)	F (in)	H (in)	K (in)	L (in)	M (in)	O (mm)	P (in)	U (in)	(lbs)	
1.28	1.53	2.31 x 1.63	1.13	1.00	0.63	0.04	0.81	0.88	-	-	-	2.3	RSM50 ¹⁾
1.69	2.13	3.25 x 2.19	1.69	1.50	0.75	0.04	1.09	1.34	-	-	-	3.1	RSM100
2.03	2.47	4.00 x 3.00	2.38	2.00	0.75	0.04	1.56	1.56	-	-	-	6.8	RSM200
2.31	2.81	4.63 x 3.75	2.88	2.50	0.75	0.08	1.88	1.75	-	-	-	10	RSM300
2.63	3.25	5.50 x 4.50	3.50	2.75	0.75	0.08	2.25	2.13	-	-	-	15	RSM500
3.13	3.75	6.50 x 5.50	4.50	3.25	0.75	0.08	2.75	2.63	-	-	-	25	RSM750
3.38	4.00	7.00 x 6.00	5.00	3.63	0.75	0.08	3.00	2.94	-	-	-	32	RSM1000
3.94	4.56	8.50 x 7.50	6.25	4.50	0.94	0.08	3.75	3.25	-	-	-	58	RSM1500
3.47	4.97	2.75	1.69	1.50	0.69	0.20	-	-	M4	0.32	1.03	6	RCS101*
3.88	5.63	3.63	2.38	2.00	0.69	0.12	-	-	M5	0.32	1.57	11	RCS201*
4.63	7.06	4.00	2.88	2.62	0.75	0.12	-	-	M5	0.32	1.57	15	RCS302*
4.81	7.19	4.88	3.50	2.75	0.94	0.08	-	-	M5	0.32	1.57	22	RCS502*
5.56	7.81	6.50	5.00	3.63	1.25	0.04	-	-	M8	0.40	2.17	46	RCS1002*

** Collapsed height with tilting saddle

▼ RLT-Series, Low-Height Telescopic Cylinder



Extended Stroke for Low-Clearance Applications



Internal Mechanics RLT-Series, Low-Height Telescopic Cylinders

Enerpac compact, low-height telescopic cylinders are available with two or three pistons, and can lift loads up to 1.57 inches in a single movement.

Nitrocarburization surface treatment for improved wear-resistance and corrosion protection for increased safety and longer service life in harsh conditions. The longer stroke length of telescopic cylinders will save you time and simplify projects by moving a load a greater distance and eliminating the use of temporary cribbing.



Multi-Stage Cylinders

1st Stage: maximum load capacity at lower stroke.

2nd Stage: extended stroke with lower capacity than the 1st stage.

Final Stage: maximum stroke extension with lowest capacity.

- Single-acting, load-return
- Nitrocarburization surface treatment for improved load and wear-resistance and corrosion protection
- For use in confined spaces: machinery positioning, tool fastening
- Mounting bolt holes for easy fixturing
- Up to 3% side-load of maximum capacity
- Design safety factor complies with ASME B30.1 & EN1494
- CR400 coupler for compatibility with standard product
- High-alloy steel for maximum strength



Cylinder Capacity at Maximum Stroke (ton)	Maximum Stroke (in)	Model Number	Collapsed Height	Extended Height	Oil Capacity (in ³)
			A (in)	B (in)	
4.8	0.67	RLT40	1.77	2.44	1.29
4.8	0.91	RLT41	2.13	3.03	3.09
12.5	0.71	RLT110	2.15	2.85	2.90
12.5	1.57	RLT111	3.50	5.08	14.71
26.1	1.06	RLT230	2.95	4.02	9.15
26.1	1.26	RLT231	3.78	5.04	18.50
34.8	1.14	RLT311	3.50	4.65	13.64
55.8	1.02	RLT501	3.78	4.80	17.29
81.7	1.02	RLT741	4.49	5.51	25.97

Low-Height Telescopic Cylinders, Single-Acting



Assisted-Return Pumps with Venturi Valve Technology

To improve productivity and

plunger retraction, Enerpac offers valve configurations designed to accelerate your cylinder retraction speeds, ZU4 and ZE-Series pumps feature **Venturi Valve Technology** to facilitate the faster return of single-acting gravity- and spring-return cylinders. See enerpac.com for details.

Page: 141



4-Way Manifold Assembly Complete with Gauges

Offering ease of portability and

convenience with an ergonomic robust design, ready for use. Enerpac's CR400 female couplers on all ports allow the manifold to be quickly connected to up to 4 cylinders. Glycerin-filled, 10,000 psi gauges allow operators to work safely. All protected by the robust protection frame.

Manifold Type (Used for cylinders)	Model Number
4x Single-acting	AMGC41
4x Double-acting	AMGC42

Page: 162

RLT Series



Capacity:

4.8 - 81.7 tons

Stroke:

0.67 - 1.57 inches

Maximum Operating Pressure:

10,150 psi



WARNING:

If several telescopic cylinders need to be controlled simultaneously, Enerpac recommends the use of Synchronous Lifting Pumps. Enerpac advises not to use SFP-Series Split-Flow Pumps unless outfitted with stroke sensors for direct feedback to operate several telescopic cylinders at one time due to the volume difference on the different stages.

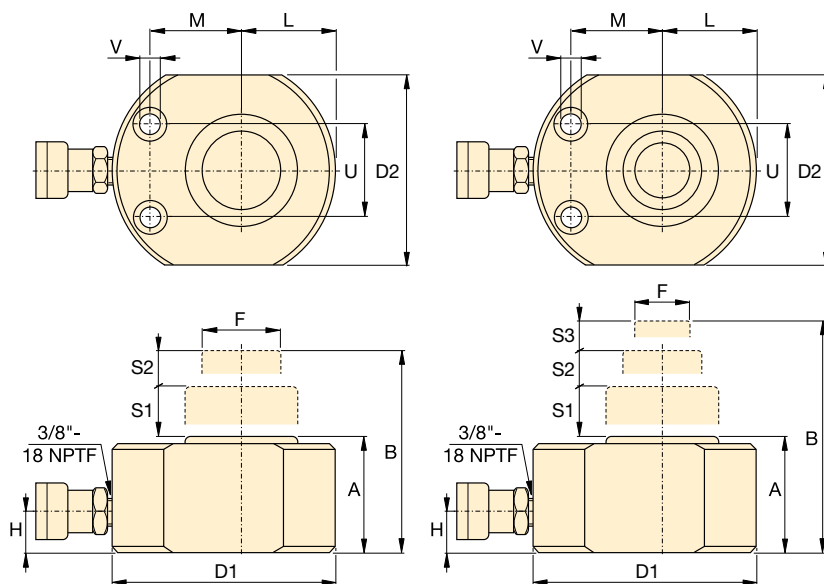

RLT-Cylinders

Mounting Hole Dimensions (in)

Model Number	Bolt Distance U	Hole Diameter V	Counter Bore Diameter	Counter Bore Depth
RLT40	1.46	0.26	0.43	0.28
RLT41	1.97	0.35	0.55	0.35
RLT110	1.97	0.35	0.55	0.35
RLT111	2.99	0.51	0.79	0.51
RLT230	2.64	0.51	0.79	0.51
RLT231	2.99	0.26	0.43	0.28
RLT311	2.99	0.51	0.79	0.51
RLT501	2.99	0.26	0.43	0.28
RLT741	4.61	0.35	0.55	0.35

1st Stage		2nd Stage		3rd Stage		Outside Diameter D1 x D2 (in)	Plunger Diameter F (in)	Bottom to Advance Port H (in)	Plunger to Base L (in)	Plunger to Mounting Hole M (in)	Weight (lbs)	Model Number
Capacity (ton)	Stroke S1 (in)	Capacity (ton)	Stroke S2 (in)	Capacity (ton)	Stroke S3 (in)							
12.5	0.43	4.8	0.24	-	-	3.27 x 2.20	0.98	0.79	1.14	1.30	4.0	RLT40
26.1	0.43	12.5	0.28	4.8	0.20	4.02 x 3.15	0.98	0.79	1.61	1.54	6.8	RLT41
26.1	0.43	12.5	0.28	-	-	4.02 x 3.15	1.50	0.79	1.61	1.54	6.6	RLT110
81.7	0.63	34.8	0.51	12.5	0.43	6.50 x 5.51	1.50	0.98	2.78	2.60	28.9	RLT111
55.8	0.63	26.1	0.43	-	-	5.51 x 4.49	2.24	0.79	2.28	2.20	16.8	RLT230
104.4	0.63	55.8	0.39	26.1	0.24	7.01 x 6.38	2.24	1.14	3.50	2.76	38.1	RLT231
81.7	0.63	34.8	0.51	-	-	6.50 x 5.51	2.36	0.98	2.78	2.60	28.7	RLT311
104.4	0.63	55.8	0.39	-	-	7.01 x 6.38	3.07	1.14	3.50	2.76	38.1	RLT501
158.2	0.63	81.7	0.39	-	-	8.50 x 7.72	3.74	1.38	4.25	3.07	67.0	RLT741

▼ Shown: **RT3311 Telescopic Cylinder** (shown with plunger extended and retracted)



- Nitrocarburized surface treatment inside and out provides corrosion protection
- 3% side-load of full capacity
- Double or triple wear bearings support lifting stages
- Tilting saddles with 5 degrees of maximum tilt standard on all models
- Design Safety factor complies with ASME B30.1 & EN1494
- Certified lifting eyes for safe handling and positioning
- CR400 coupler for compatibility with standard product
- Steel cylinder base for maximum strength

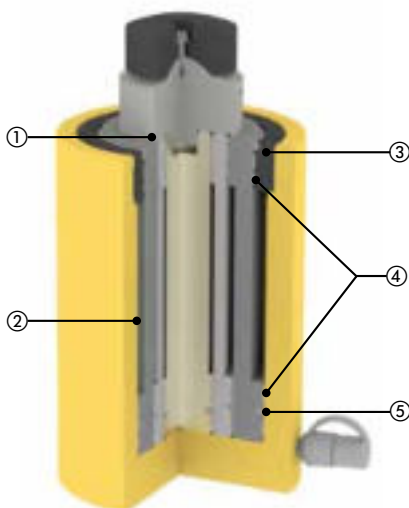

- ① **Wiper Ring** on each stage to minimize contamination.
- ② **Nitrocarburized Coating** for maximum corrosion protection and surface hardness. Exterior in nitrided and Enerpac yellow epoxy.
- ③ **Stop-Ring** full load capable to prevent plunger overstroke.
- ④ **Wear Bearings.** Double or triple wear bearings for maximum sideload capability and wear-resistance.
- ⑤ **Seals** for maximum compliance and high wear-resistance.

Moving a Load a Greater Distance



RT-Series, Multi-Stage Cylinders

Enerpac compact, multi-stage telescopic cylinders are available with two or three pistons, and can lift loads up to 24 inches in a single movement.

Nitrocarburized surface treatment inside and out provides unparalleled sideload resistance and corrosion protection for safe use in the harshest conditions. The longer stroke length of telescopic cylinders will save you time and simplify projects by moving a load a greater distance and eliminating the use of temporary cribbing.



Integrated Tilt Saddles

All RT-Series cylinders include integrated tilt saddles with maximum tilt angles up to 5 degree.



Lifting Eyes

All models standard with two lifting eyes for easy handling and positioning.

Model No.	Maximum Stroke (in)	Capacity @ Maximum Stroke (ton)	Oil Capacity (in ³)
RT1510	10.63	15.4	57.61
RT1817	17.13	18.7	188.69
RT2111	11.81	22.2	90.74
RT2119	19.69	22.2	284.43
RT3311	11.81	34.8	143.96
RT3323	23.62	34.8	537.99

Multi-Stage Telescopic Cylinders, Single-Acting, Load-Return



About Telescopic Cylinders

Telescopic cylinders feature a multi-stage rod built of a series of nested steel tubes of progressively smaller diameter. These long stroke, multi-stage telescopic cylinders are particularly suitable for extended lift heights when clearance is limited.

Enerpac's Telescopic Cylinders are available with two or three pistons, and can lift loads up to 24 inches in a single movement.

Each piston rod is nitrocarburized for superior corrosion protection and enhanced durability.

RT Series



Capacity:

15.4 - 34.8 ton

Stroke:

10.63 - 23.62 inches

Maximum Operating Pressure:

10,150 psi



Multi-Stage Cylinders

1st Stage: maximum load capacity at lowest maximum stroke

2nd Stage: extended stroke but at lower maximum capacity than the 1st stage

Final Stage: maximum stroke extension but lowest maximum capacity

▼ *The longer stroke length of telescopic cylinders will save you time and simplify projects by moving a load a greater distance and eliminating the use of temporary cribbing.*

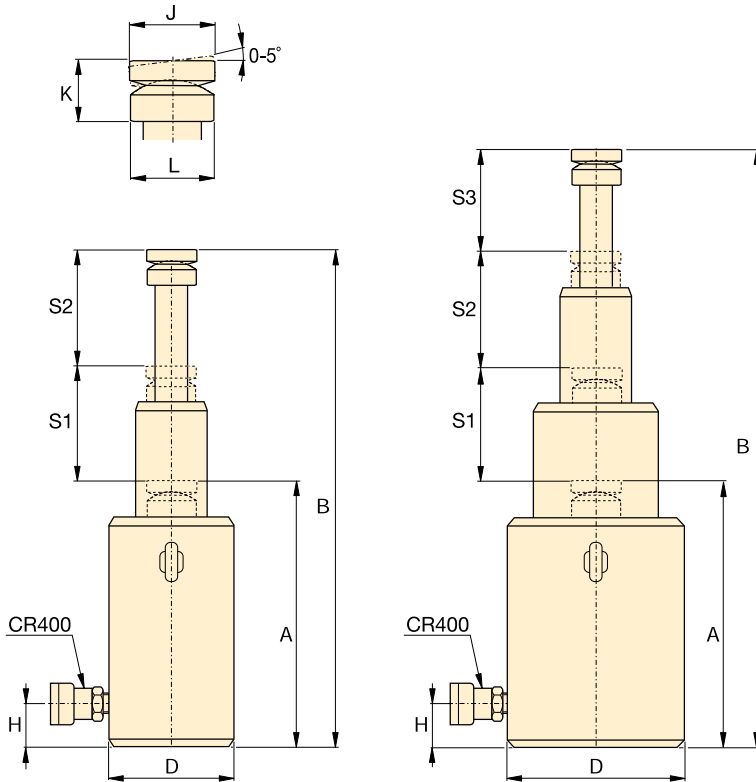

Stage 1		Stage 2		Stage 3		Collapsed Height A (in)	Extended Height B (in)	Outside Diameter D (in)	Base to Adv. Port H (in)	Saddle Diam. J (in)	Saddle Protrusion from Plunger K (in)	Saddle Support L (in)	Wt. (lbs)	Model Number
Capacity (ton)	Stroke S1 (in)	Capacity (ton)	Stroke S2 (in)	Capacity (ton)	Stroke S3 (in)									
40	5.31	15	5.31	-	-	11.14	21.77	4.33	0.79	2.36	1.93	2.36	33	RT1510
104	5.71	45	5.71	19	5.71	13.58	30.71	6.69	1.06	3.15	2.87	3.35	89	RT1817
56	5.91	22	5.91	-	-	12.48	24.29	4.92	0.91	2.36	2.09	2.60	48	RT2111
139	6.69	56	6.69	22	6.30	15.55	35.24	7.87	1.34	3.54	3.27	3.94	148	RT2119
89	5.91	35	5.91	-	-	13.86	25.67	6.30	0.98	3.15	2.60	3.50	88	RT3311
223	7.87	89	7.87	34.7	7.87	18.74	42.36	9.84	1.73	4.33	4.37	4.84	273	RT3323

▼ Shown from left to right: BRC25, BRC46, BRP306, BRP606, BRP106C



The Ultimate in Pulling Power



Gauges

Minimize the risk of over-loading and ensure long, dependable service from your equipment. Refer to the System Components section for a full range of gauges.

Page: 147



Attachments and Accessories

The BRC25 and BRC46 units have base, collar and plunger threads to affix a range of optional attachments and accessories, such as chains, saddles and extension tubes.

Page: 206

- High-strength alloy steel construction
- Plunger blow-out protection to prevent over-extension
- Hard chrome-plated plunger for long life
- Baked enamel finish for increased corrosion resistance
- CR400 coupler and dust cap included on all models
- Plunger wiper reduces contamination, extending cylinder life
- Single-acting spring-return
- Replaceable links on BRP-models

▼ Ship building, welding and Enerpac pull cylinders go hand in hand.



▼ To lift a load bearing mast into place, BRP cylinders were used to tension the supporting cables.

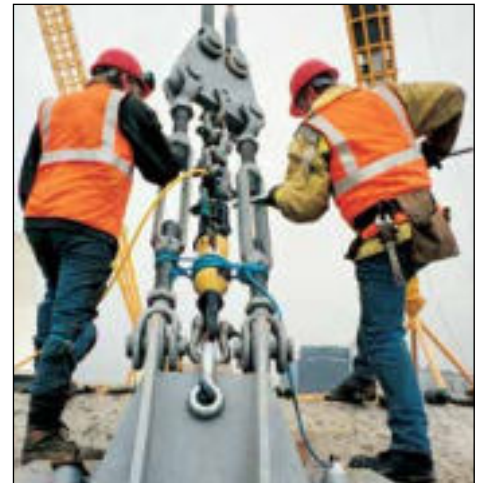

Single-Acting, Pull Cylinders

BRC Cylinder Mounting Dimensions (in)				
Model Number	Base Mounting Hole	Collar Thread	Collar Thread Length	Mtg. Thread Length
	V	W	X	Z
BRC25	3/4"-14 NPT	1 1/2"-16 UN	0.98	0.67
BRC46	1 1/4"-11 1/2" NPT	2 1/4"-14 UN	1.06	0.98
BRC106	M30 x 2	M85 x 2	1.02	0.98

**BRC
BRP
Series**



Capacity:

2.5 - 60 tons

Stroke:

5.00 - 6.06 inches

Maximum Operating Pressure:

10,000 psi

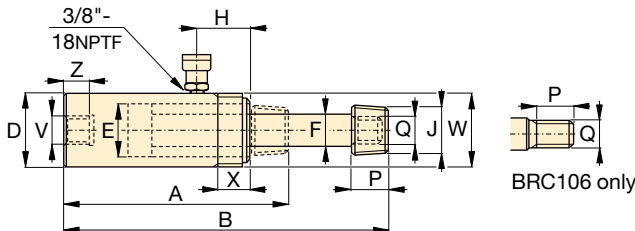

BRC25 to BRC106

Cylinder Capacity	Stroke	Model Number	Cyl. Effect. Area	Oil Cap.	Collap. Height	Ext. Height	Outside Diam.	Cyl. Bore Diam.	Plgr. Diam.	Top to Inlet Port	Saddle Diameter	Plunger Thread Length	Plunger Outside Thread	Weight
(tons) [maximum]	(in)		(in ²)	(in ³)	A (in)	B (in)	D (in)	E (in)	F (in)	H (in)	J (in)	P (in)	Q	(lbs)
2.5 [2.7]	5.00	BRC25	0.55	2.76	10.44	15.44	1.89	1.13	0.75	1.77	3/4"-14 NPT	1.13	1 1/16"-24	4
5 [5.6]	5.50	BRC46	1.13	6.21	11.88	17.38	2.25	1.69	1.19	1.69	1 1/4"-11 1/2" NPT	1.25	1 3/16"-16	10
10 [11.6]	5.95	BRC106	2.32	13.80	11.38	17.33	3.35	2.13	1.25	1.57	-	1.02	M30x2	21

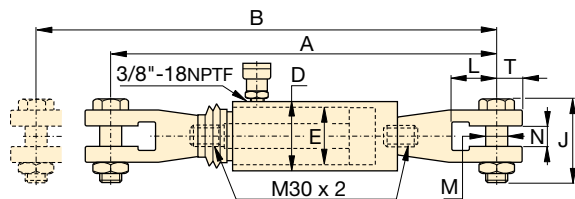

BRP106C

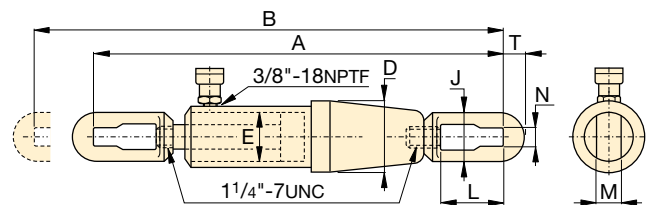

BRP306

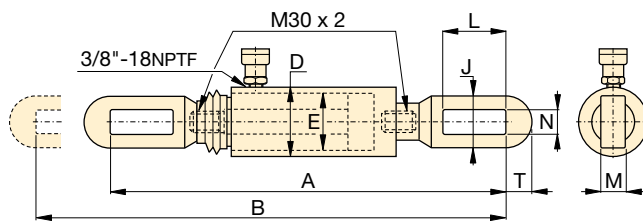

BRP106L

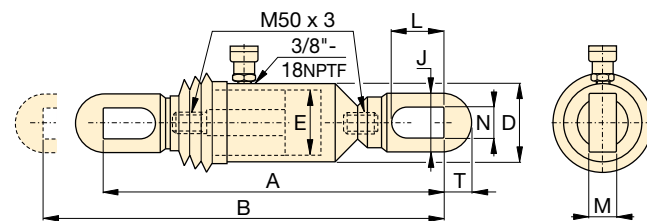

BRP606

Cylinder Capacity	Stroke	Model Number	Cyl. Effect. Area	Oil Capacity	Collap. Height	Ext. Height	Outside Diam.	Cyl. Bore Diam.	Link Height	Link Opening	Link Thickness	Link Width	Slot to Link End	Weight
(tons) [maximum]	(in)		(in ²)	(in ³)	A (in)	B (in)	D (in)	E (in)	J (in)	L (in)	M (in)	N (in)	T (in)	(lbs)
10 [11.6]	5.91	BRP106C	2.45	14.58	23.66	29.57	3.35	2.13	4.13	3.43	1.18	1.38	1.28	34
	5.91	BRP106L	2.45	14.58	22.56	28.46	3.35	2.13	2.52	4.69	0.87	1.19	1.26	29
30 [35.96]	6.06	BRP306	7.19	43.63	43.71	49.71	5.39	3.50	4.49	6.10	1.38	1.70	2.17	139
60 [55.8]	6.02	BRP606	11.17	67.02	28.28	34.28	5.51	4.33	5.12	5.93	1.58	1.89	2.56	129

Note: BRP106C, BRP106L and BRP606 are fitted with rubber bellows for rod protection.

▼ Shown from left to right: RCH306, RCH120, RCH1003



- Hollow plunger design allows for both pull and push forces
- Single-acting spring-return
- Nickel-plated, floating center tube on models over 20 tons increases product life
- Baked enamel finish for increased corrosion resistance
- Collar threads for easy fixturing
- RCH120 includes AR630 coupler and has 1/4 NPTF port
- RCH121 and RCH1211 have FZ1630 reducer and AR630 coupler, all other models feature CR400 coupler

▼ Hollow plunger cylinder RCH1003 used in an application for intermediate boom suspension on a dragline.



Versatility in Testing, Maintenance and Tensioning Applications

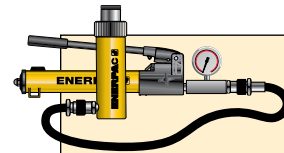

Pump and Cylinder Sets

All cylinders marked with an * are available as **sets** (cylinder, gauge, couplers, hose and pump) for your ordering convenience.

Page: 62



Lightweight Aluminum Hollow Plunger Cylinders

If you need a higher cylinder capacity-to-weight ratio the lightweight **RACH-Series**

Aluminum Hollow Plunger Cylinders are the perfect choice.

Page: 16



Saddles

Most **RCH-Series** cylinders are equipped with smooth saddles. See table on next page for optional threaded saddles and all dimensional information.

Page: 35

Cylinder Capacity	Stroke	Model Number	Cyl. Effect. Area	Oil Cap.
(tons) [maximum]	(in)		(in ²)	(in ³)
12 [13.8]	0.31	RCH120	2.76	0.86
	1.63	RCH121*	2.76	4.49
	1.63	RCH1211	2.76	4.49
	3.00	RCH123	2.76	8.29
20 [23.6]	2.00	RCH202*	4.72	9.46
	6.10	RCH206	4.72	28.67
30 [36.1]	2.50	RCH302*	7.22	18.05
	6.13	RCH306	7.22	44.23
60 [63.6]	3.00	RCH603*	12.73	38.20
	6.00	RCH606	12.73	76.41
100 [103.1]	3.00	RCH1003*	20.63	61.88

* Available as a set. See note on this page.

Single-Acting, Hollow Plunger Cylinders



Hoses

Enerpac offers a complete line of high quality hydraulic hoses. To ensure the integrity of your system, specify only Enerpac hydraulic hoses.

Page: 148

RCH Series

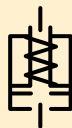

Capacity:

12 - 100 tons

Stroke:

0.31 - 6.13 inches

Center Hole Diameter:

0.77 - 3.11 inches

Maximum Operating Pressure:

10,000 psi

Optional Threaded Hollow Saddles

Saddle Type	Cylinder Model No.	Saddle Model No.	Saddle Dimensions (in)		
			A	B	C
Threaded Hollow	RCH202, 206	HP2015	2.11	1"-8	0.38
	RCH302, 306	HP3015	2.49	1¼"-7	0.38
	RCH603, 606	HP5016	3.61	1½"-5½"	0.50
	RCH1003	HP10016	4.97	2½"-8	0.51

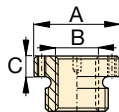

Smooth hollow saddles are standard on all RCH models (12-ton models are not equipped with saddles).

RCH121 and RCH1211 have a 1.88" diameter boss that protrudes 0.25" from base.

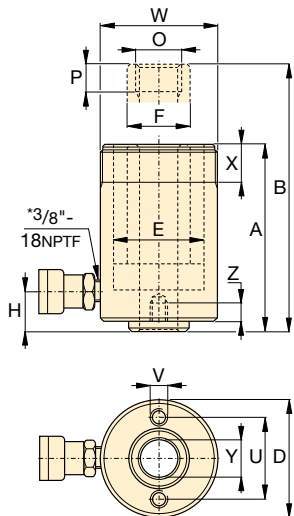

RCH120* to RCH123 models

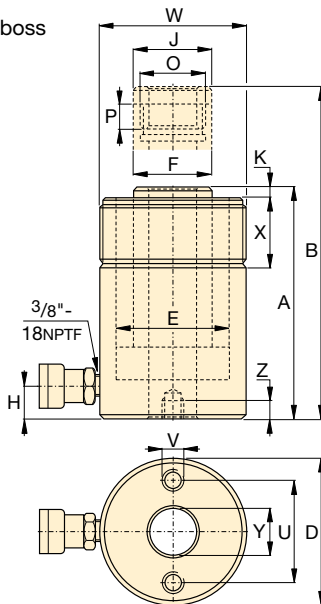

RCH202 to RCH1003 models

Base Mounting Hole Dimensions (in)			
Model Number	Bolt Circle	Thread	Thread Depth
	U	V	Z
RCH120	2.00	5/16"-18 UNC	0.35
RCH121	-	-	-
RCH1211	-	-	-
RCH123	2.00	5/16"-18 UNC	0.50
RCH202	3.25	3/8"-16 UNC	0.37
RCH206	3.25	3/8"-16 UNC	0.37
RCH302	3.63	3/8"-16 UNC	0.55
RCH306	3.63	3/8"-16 UNC	0.55
RCH603	5.13	1/2"-13 UNC	0.55
RCH606	5.13	1/2"-13 UNC	0.55
RCH1003	7.00	5/8"-11 UNC	0.75

* 1/4" NPT for RCH120 only

Collap. Height	Ext. Height	Outside Diam.	Cyl. Bore Diam.	Plngr. Diam.	Cyl. Base to Advance Port	Saddle Diameter	Saddle Protrusion from Plngr.	Plunger Internal Thread	Plunger Thread Length	Collar Thread	Collar Thread Length	Center Hole Diam.	Weight	Model Number
A	B	D	E	F	H	J	K	O	P	W	X	Y	(lbs)	
(in)	(in)	(in)	(in)	(in)	(in)	(in)	(in)	(in)	(in)	(in)	(in)	(in)		
2.19	2.50	2.75	2.13	1.38	0.38	-	-	3/4"-16 UN	0.63	2¾"-16	1.19	0.77	3.2	RCH120
4.75	6.38	2.75	2.13	1.38	0.98	-	-	-	-	2¾"-16	1.19	0.77	6.2	RCH121*
4.75	6.38	2.75	2.13	1.38	0.98	-	-	3/4"-16 UN	0.63	2¾"-16	1.19	0.77	6.2	RCH1211
7.25	10.25	2.75	2.13	1.38	0.98	-	-	-	-	2¾"-16	1.19	0.77	9.8	RCH123
6.38	8.38	3.88	2.88	2.13	0.75	2.13	0.27	1 ⁹ / ₁₆ "-16 UN	0.75	3 ⁷ / ₈ "-12	1.50	1.06	17	RCH202*
12.05	18.11	3.88	2.88	2.13	0.75	2.13	0.27	1 ⁹ / ₁₆ "-16 UN	0.75	3 ⁷ / ₈ "-12	1.50	1.06	31	RCH206
7.03	9.53	4.50	3.50	2.50	0.85	2.50	0.38	1 ¹³ / ₁₆ "-16 UN	0.88	4½"-12	1.66	1.31	24	RCH302*
13.00	19.13	4.50	3.50	2.50	1.00	2.50	0.38	1 ¹³ / ₁₆ "-16 UN	0.88	4½"-12	1.66	1.31	48	RCH306
9.75	12.75	6.25	4.88	3.63	1.25	3.61	0.50	2 ³ / ₄ "-16 UN	0.75	6¼"-12	1.91	2.12	62	RCH603*
12.75	18.75	6.25	4.88	3.63	1.25	3.61	0.50	2 ³ / ₄ "-16 UN	0.75	6¼"-12	1.91	2.12	78	RCH606
10.00	13.00	8.38	6.50	5.00	1.50	4.97	0.50	4"-16 UN	1.00	8 ³ / ₈ "-12	2.38	3.11	132	RCH1003*

▼ Shown from left to right: RRH3010, RRH1001, RRH6010



Versatility in Testing, Maintenance and Tensioning Applications



Pump Selection

A double-acting cylinder must be powered by a pump with a 4-way valve.

Page: 139



Gauges

Minimize the risk of overloading and ensure long, dependable service from your equipment. Refer to the System Components section for a full range of gauges.

Page: 147



Saddles

All RRH-Series cylinders are equipped with smooth saddles. See table on next page for optional threaded saddles and all dimensional information.

Page: 36

- Relief valves prevent damage in case of over-pressurization
- Baked enamel finish for increased corrosion resistance
- Collar threads enable easy fixturing (except RRH1001 and RRH1508)
- Double-acting operation for fast retraction
- Nickel-plated, floating center tube increases product life
- Hollow plunger allows for both pull and push forces
- CR400 couplers and dust caps included on all models
- Plunger wiper reduces contamination, extending cylinder life

▼ Double-acting hollow-plunger cylinders are applied for bridge launching systems.



Cylinder Capacity (ton)	Stroke (in)	Model Number	Max. Cylinder Capacity (ton)		Cylinder Effective Area (in ²)		Oil Capacity (in ³)	
			Advance	Retract	Advance	Retract	Advance	Retract
30	7.00	RRH307	36	24	7.22	4.71	50.55	32.99
	10.13	RRH3010	36	24	7.22	4.71	73.12	47.71
60	3.50	RRH603	64	42	12.73	8.37	44.57	29.21
	6.50	RRH606	64	42	12.73	8.37	82.77	54.24
	10.12	RRH6010	64	42	12.73	8.37	128.94	84.49
100	1.50	RRH1001	103	68	20.63	13.54	30.94	20.32
	3.00	RRH1003	103	68	20.63	13.54	61.88	40.64
	6.00	RRH1006	103	68	20.63	13.54	123.76	81.29
	10.13	RRH10010	103	68	20.63	13.54	208.84	137.17
150	8.00	RRH1508	158	80	31.62	15.91	252.97	127.23

Double-Acting, Hollow Plunger Cylinders



Hoses

Enerpac offers a complete line of high-quality hydraulic hoses. To ensure the integrity of your system, specify only Enerpac hydraulic hoses.

Page: 148

RRH Series

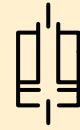

Capacity:

30 - 150 tons

Stroke:

1.50 - 10.13 inches

Center Hole Diameter:

1.31 - 3.13 inches

Maximum Operating Pressure:

10,000 psi

Optional Threaded Hollow Saddles

Saddle Type	Cylinder Model Number	Saddle Model No.	Saddle Dimensions (in)		
			A	B	C
Threaded Hollow	RRH307, 3010	HP3015	2.49	1 1/4"-7	0.38
	RRH603, 606, 6010	HP5016	3.61	1 5/8"-5 1/2	0.50
	RRH1001, 1003, RRH1006, 10010	HP10016	4.97	2 1/2"-8	0.51

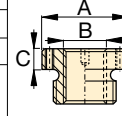

Smooth hollow saddles are standard on all RRH-models.

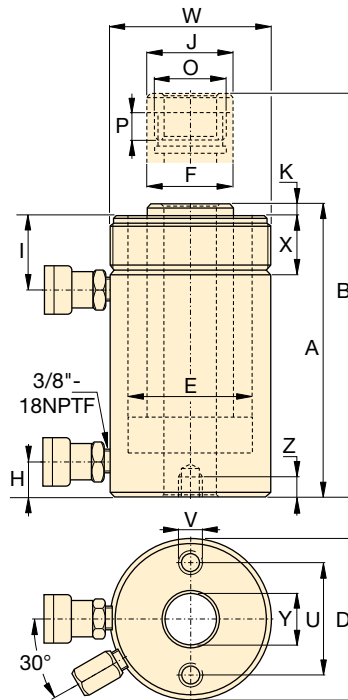

Base Mounting Hole Dimensions (in)

Model Number	Bolt Circle U	Thread V	Thread Depth Z
RRH307	3.63	3/8" - 16	0.62
RRH3010	3.63	3/8" - 16	0.62
RRH603	5.12	1/2" - 13	0.55
RRH606	5.12	1/2" - 13	0.55
RRH6010	5.12	1/2" - 13	0.55
RRH1001	7.00	5/8" - 11	0.75
RRH1003	7.00	5/8" - 11	0.75
RRH1006	7.00	5/8" - 11	0.75
RRH10010	7.00	5/8" - 11	0.75
RRH1508	8.60	5/8" - 11	0.90

Collap. Height	Ext. Height	Out. Diam.	Cyl. Bore Diam.	Plngr. Diam.	Cyl. Base to Adv. Port	Cyl. Top to Return Port	Saddle Diam.	Saddle Protrusion from Plngr.	Thread	Plunger Thread Length	Collar Thread	Collar Thread Length	Center Hole Diam.	Wt.	Model Number
A	B	D	E	F	H	I	J	K	O	P	W	X	Y	(lbs)	
(in)	(in)	(in)	(in)	(in)	(in)	(in)	(in)	(in)	(in)	(in)	(in)	(in)	(in)		
13.00	20.00	4.50	3.50	2.50	1.00	2.38	2.50	0.38	1 13/16"-16	0.88	4 1/2"-12	1.66	1.31	48	RRH307
17.00	27.13	4.50	3.50	2.50	1.00	2.38	2.50	0.38	1 13/16"-16	0.88	4 1/2"-12	1.66	1.31	60	RRH3010
9.75	13.25	6.25	4.88	3.63	1.25	2.63	3.61	0.50	2 3/4"-16	0.75	6 1/4"-12	1.91	2.13	62	RRH603
12.75	19.25	6.25	4.88	3.63	1.25	2.63	3.61	0.50	2 3/4"-16	0.75	6 1/4"-12	1.91	2.13	78	RRH606
17.25	27.38	6.25	4.88	3.63	1.25	2.63	3.61	0.50	2 3/4"-16	0.75	6 1/4"-12	1.91	2.13	101	RRH6010
6.50	8.00	8.38	6.50	5.00	1.50	1.75	4.97	0.50	4"-16	1.00	-	-	3.13	85	RRH1001
10.00	13.00	8.38	6.50	5.00	1.50	3.38	4.97	0.50	4"-16	1.00	8 3/8"-12	2.38	3.13	135	RRH1003
13.50	19.50	8.38	6.50	5.00	1.50	3.38	4.97	0.50	4"-16	1.00	8 3/8"-12	2.38	3.13	175	RRH1006
18.13	28.25	8.38	6.50	5.00	1.50	3.38	4.97	0.50	4"-16	1.00	8 3/8"-12	2.38	3.13	235	RRH10010
13.75	21.75	9.75	7.50	6.00	1.50	2.38	5.00	0.19	4 1/4"-12	1.00	-	-	3.13	245	RRH1508

▼ Shown from left to right: RD2510, RD96, RD256, RD41, RD166



High Precision and High Cycle Performance



Speed Chart

See the Enerpac Cylinder Speed Chart in our 'Yellow Pages' to determine your approximate cylinder speed.

Page: 409

- Designed for long life, the best choice for production applications
- Unique mounting configurations simplify fixturing
- Baked enamel finish for increased corrosion resistance
- Double-acting operation develops force in both directions, providing maximum versatility
- Plunger wiper reduces contamination, extending cylinder life

▼ Clamping application using Enerpac RD cylinders (with clevis eye attachments on both ends) for their high-pressure capability and mounting flexibility.



Cylinder Capacity (tons)	Stroke (in)	Model Number	Max. Cylinder Capacity (tons)		Cylinder Effective Area (in ²)		Oil Capacity (in ³)		Collap. Height A (in)	Ext. Height B (in)	Body Length C (in)	Outside Diam. D (in)	Cylinder Bore Diam. E (in)	Plunger Diam. F (in)
			Advance	Retract	Advance	Retract	Advance	Retract						
4	1.13	RD41	4	2	0.79	0.34	0.88	0.39	7.31	8.44	6.38	2.00	1.00	0.75
	3.13	RD43	4	2	0.79	0.34	2.45	1.07	9.31	12.44	8.38	2.00	1.00	0.75
	6.13	RD46	4	2	0.79	0.34	4.81	2.10	12.31	18.44	11.38	2.00	1.00	0.75
9	1.13	RD91	9	5	1.77	0.98	1.99	1.10	8.75	9.88	7.80	2.50	1.50	1.00
	3.13	RD93	9	5	1.77	0.98	5.52	3.07	10.78	13.91	9.80	2.50	1.50	1.00
	6.13	RD96	9	5	1.77	0.98	10.82	6.01	13.78	19.91	12.80	2.50	1.50	1.00
	10.13	RD910	9	5	1.77	0.98	17.89	9.94	17.78	27.91	16.81	2.50	1.50	1.00
16	6.25	RD166	16	8	3.14	1.66	19.63	10.35	15.31	21.56	14.13	3.00	2.00	1.38
	10.25	RD1610	16	8	3.14	1.66	32.20	16.98	19.31	29.56	18.11	3.00	2.00	1.38
25	6.25	RD256	25	11	4.91	2.15	30.68	13.42	16.69	22.94	15.63	3.63	2.50	1.88
	10.25	RD2510	25	11	4.91	2.15	50.31	22.01	20.69	30.94	19.61	3.63	2.50	1.88

Double-Acting, Precision Production Cylinders

▼ RD CYLINDER ATTACHMENTS

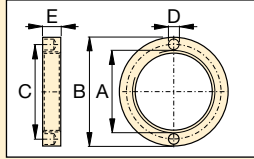

Retainer Nut
For locking foot or flange mountings. Tightens onto cylinder collar threads (included with foot and flange mounting kits)

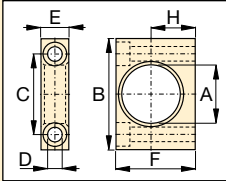

Foot Mounting
Mounts onto cylinder collar. Mounting screws not included.

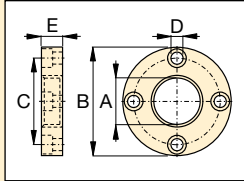

Flange Mounting
Mounts onto cylinder collar. Mounting screws not included.

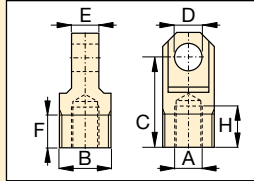

Clevis Eye
Threads onto plunger or into cylinder base

RD Series



Capacity:
4 - 25 tons

Stroke:
1.13 - 10.25 inches

Maximum Operating Pressure:
10,000 psi

Model Number	RD-Cyl: (tons)	Dimensions (in)						
		A	B	C	D	E	F	H
Foot Mounting with Retainer Nut								
AD141	4	1.38	3.00	2.00	0.41	0.75	2.25	1.25
AD171	9	2.00	4.00	2.88	0.53	1.00	3.25	1.75
AD181	16	2.63	5.00	3.75	0.78	1.38	4.00	2.06
AD191	25	3.25	6.25	4.62	1.03	1.75	4.88	2.50
Flange Mounting with Retainer Nut								
AD142	4	1.38	3.88	3.09	0.41	0.75	-	-
AD172	9	2.00	4.75	3.88	0.41	1.00	-	-
AD182	16	2.63	5.63	4.56	0.53	1.38	-	-
AD192	25	3.25	6.50	5.34	0.66	1.75	-	-
Retainer Nut								
AD143	4	1.375-12 UNF	2.25	1.81	0.25	0.38	-	-
AD173	9	2.000-12 UN	3.00	2.50	0.27	0.50	-	-
AD183	16	2.625-16 UN	3.63	3.12	0.27	0.75	-	-
AD193	25	3.250-16 UN	4.25	3.75	0.27	1.00	-	-
Clevis Eye (See chart below for mounting dimensions L, L1 and M)								
AD150	4	0.500-20 UNF	1.125-20 UN	2.06	0.63	0.62	0.75	0.94
AD151	9	0.750-16 UNF	1.688-18 UNEF	2.25	0.75	1.00	1.00	0.94
AD152	16	1.125-12 UNF	2.188-16 UNS	3.06	1.00	1.25	1.00	1.19
AD153	25	1.500-12 UNF	2.750-16	3.06	1.25	1.50	1.00	1.06

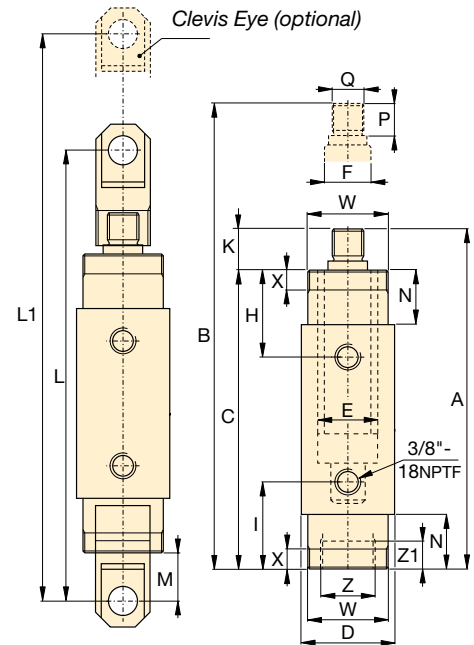

Top to Ret. Port H (in)	Bottom to Adv. Port I (in)	Plunger Protrusion K (in)	Clevis Eye Mounting Dimensions			Neck Length N (in)	Plunger Thread Length P (in)	Plunger External Thread Q (in)	Cylinder Mounting Dimensions (in)				Wt. (lbs)	Model Number
			L (in)	L1 (in)	M (in)				Collar Thread W	Collar Thread Length X	Int. Base Thread Z	Int. Base Thread Length Z1		
1.88	1.88	0.94	10.12	11.25	1.61	1.13	0.75	1/2"-20	1 3/8"-12	0.44	1 1/8"-20	0.35	4.8	RD41
1.88	1.88	0.94	12.12	15.25	1.61	1.13	0.75	1/2"-20	1 3/8"-12	0.44	1 1/8"-20	0.35	6.4	RD43
1.88	1.88	0.94	15.12	21.25	1.61	1.13	0.75	1/2"-20	1 3/8"-12	0.44	1 1/8"-20	0.35	9.0	RD46
2.27	2.27	0.98	11.61	12.76	1.50	1.50	0.75	3/4"-16	2"-12	0.56	1 11/16"-18	0.55	9.0	RD91
2.27	2.27	0.98	13.66	16.79	1.50	1.50	0.75	3/4"-16	2"-12	0.56	1 11/16"-18	0.55	11.0	RD93
2.27	2.27	0.98	16.66	22.79	1.50	1.50	0.75	3/4"-16	2"-12	0.56	1 11/16"-18	0.55	14.0	RD96
2.27	2.27	0.98	20.66	30.79	1.50	1.50	0.75	3/4"-16	2"-12	0.56	1 11/16"-18	0.55	19.0	RD910
2.90	2.90	1.19	19.32	25.57	2.05	2.13	1.00	1 1/8"-12	2 5/8"-16	0.88	2 3/16"-16	0.94	22.0	RD166
2.90	2.90	1.19	23.32	33.57	2.05	2.13	1.00	1 1/8"-12	2 5/8"-16	0.88	2 3/16"-16	0.94	29.0	RD1610
3.50	3.50	1.06	20.86	27.11	2.09	2.75	1.00	1 1/2"-12	3 1/4"-16	1.13	2 3/4"-16	1.02	36.0	RD256
3.50	3.50	1.08	24.86	35.11	2.09	2.75	1.00	1 1/2"-12	3 1/4"-16	1.13	2 3/4"-16	1.02	46.0	RD2510

▼ Shown from left to right: RR10013, RR1502, RR20013, RR1010, RR7513



- Collar threads, plunger threads and base mounting holes for easy fixturing (on most models)
- Baked enamel finish for increased corrosion resistance
- Removable hardened saddles protect plunger during lifting and pressing
- Built-in safety valve prevents accidental over-pressurization
- CR400 couplers included on all models
- Plunger wiper reduces contamination, extending cylinder life

▼ These long stroke RR-cylinders are attached to a sliding and guiding system pulling the arched roof assembly of Athen's Olympic Stadium step-by-step into the final position.



Most Versatile Performers

Rugged enough for the toughest job site uses and precision designed for high-cycle industrial uses.



Saddles

RR-Series cylinders up to 75-ton have plunger thread for installation of **CATS-Series** tilt saddles.

Tilt saddles are secured to the plunger, enabling horizontal and upside-down use.

Page: 41



Optimum Performance

Enerpac's range of **Z-Class** electric pumps, fitted with manual or solenoid operated 4-way valves, offer optimum combinations with RR cylinders.

Page: 104

▼ RR-cylinders provide power and precision in a special hydraulic press.



Double-Acting Long Stroke Cylinders



Pump Selection

A double-acting cylinder must be powered by a pump with a 4-way valve.

Page: 139

▼ QUICK SELECTION CHART

For complete technical information see next page.

Cylinder Capacity (tons)	Stroke (in)	Model Number	Cylinder Effective Area (in ²)		Oil Capacity (in ³)		Collap. Height (in)
			Push	Pull	Push	Pull	
10	10.00	RR1010*	2.23	0.80	22.33	8.00	16.13
	12.00	RR1012*	2.23	0.80	26.80	9.00	18.00
30	8.25	RR308*	6.51	3.00	53.67	25.00	15.50
	14.50	RR3014*	6.51	3.00	92.70	43.00	21.63
50	6.13	RR506	11.06	3.40	67.77	21.00	13.06
	13.13	RR5013	11.06	3.40	145.17	44.00	20.06
	20.13	RR5020	11.06	3.40	222.56	68.00	28.88
75	6.13	RR756	15.92	4.90	97.58	29.00	13.69
	13.13	RR7513	15.92	4.90	209.00	64.00	20.69
100	6.63	RR1006	20.65	9.60	136.93	63.00	14.06
	13.13	RR10013	20.65	9.60	271.17	126.00	20.63
	18.13	RR10018	20.65	9.60	374.44	174.00	27.06
150	2.25	RR1502	30.71	14.80	69.11	33.00	7.19
	6.13	RR1506	30.71	14.80	188.28	91.00	15.19
	13.13	RR15013	30.71	14.80	403.27	194.00	22.20
	32.13	RR15032	30.71	14.80	986.84	475.00	43.94
200	6.00	RR2006	44.21	22.50	265.28	135.00	16.94
	13.00	RR20013	44.21	22.50	574.78	293.00	23.94
	18.00	RR20018	44.21	22.50	795.85	396.00	30.13
	24.00	RR20024	44.21	22.50	1,061	528.00	36.13
	36.00	RR20036	44.21	22.50	1,592	792.00	48.13
	48.00	RR20048	44.21	22.50	2,122	1,056	60.13
300	6.00	RR3006	70.93	38.00	425.56	228.00	19.13
	12.00	RR30012	70.93	38.00	851.12	456.00	25.13
	18.00	RR30018	70.93	38.00	1,277	684.00	31.13
	24.00	RR30024	70.93	38.00	1,702	912.00	37.13
	36.00	RR30036	70.93	38.00	2,553	1,368	49.13
	48.00	RR30048	70.93	38.00	3,405	1,824	61.13
400	6.00	RR4006	95.09	51.00	570.51	306.00	21.19
	12.00	RR40012	95.09	51.00	1,141	612.00	27.19
	18.00	RR40018	95.09	51.00	1,712	918.00	33.19
	24.00	RR40024	95.09	51.00	2,282	1,224	39.19
	36.00	RR40036	95.09	51.00	3,423	1,836	51.19
	48.00	RR40048	95.09	51.00	4,564	2,448	63.19
500	6.00	RR5006	113.15	63.00	678	378.00	22.75
	12.00	RR50012	113.15	63.00	1,358	756.00	28.75
	18.00	RR50018	113.15	63.00	2,037	1,134	34.75
	24.00	RR50024	113.15	63.00	2,716	1,512	40.75
	36.00	RR50036	113.15	63.00	4,074	2,264	52.75
	48.00	RR50048	113.15	63.00	5,431	3,024	64.75

RR Series



Capacity:

10 - 500 tons

Stroke:

2.25 - 48.00 inches

Maximum Operating Pressure:

10,000 psi



HCR-Series Cylinders

If you do not have a high-cycle application, Enerpac HCR-Series cylinders may be the right alternative.

Page: 52



Speed Chart

See the Enerpac Cylinder Speed Chart in our "Yellow Pages" to determine your approximate cylinder speed.

Page: 409



Optional Snap-in Saddles

Optional snap-in saddles for RR-Series double-acting cylinders:

Saddle Type	Cylinder Model Number	Saddle Model Number
Flat	RR10	A102F
Tilt	RR10	CATS12
	RR30	CATS52
	RR50, RR75	CATS100

Standard Saddles

Grooved	RR10	A102G
	RR30	A252G

For additional information on saddles:

Page: 10



Cylinder retract capacity for certain RR cylinders may be less than theoretical values, as a result of reduced relief valve pressure settings:

RR308/3014:4000 psi
 RR506/5013/5020:6950 psi
 RR756/7513:7200 psi

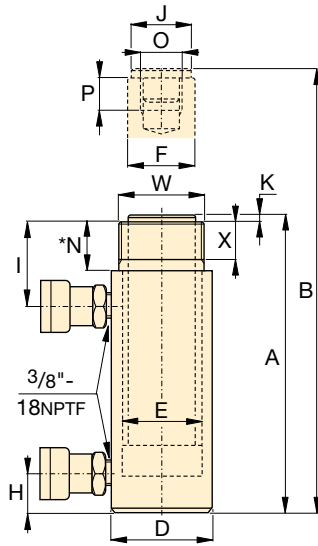

RR1010 to RR3014 models

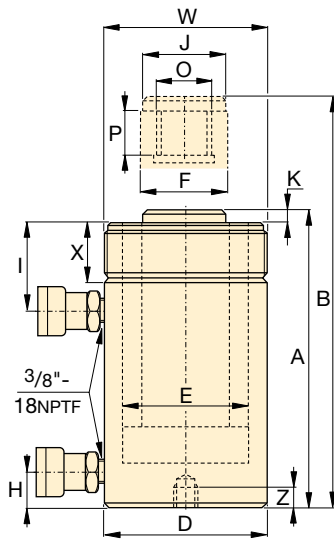

RR506 to RR50048 models

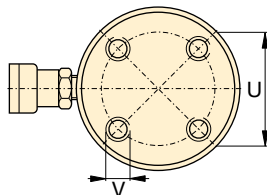

RR1006 to RR30048

No mounting holes:

- RR506, 5013
- RR756, 7513
- RR1502, 15032

◀ For full features see page 41.

Cylinder Capacity	Stroke	Model Number	Max. Cylinder Capacity		Cylinder Effective Area		Oil Capacity		Collap. Height	Ext. Height	Outside Diam.
			(tons)		(in ²)		(in ³)				
			(ton)	(in)	Push	Pull	Push	Pull	Push	Pull	A (in)
10	10.00	RR1010*	11.1	4.0	2.23	0.80	22.33	8.00	16.13	26.13	2.88
	12.00	RR1012*	11.1	4.0	2.23	0.80	26.80	9.00	18.00	30.00	2.88
30	8.25	RR308*	32.5	6.0	6.51	3.00	53.67	25.00	15.50	23.75	4.00
	14.50	RR3014*	32.5	6.0	6.51	3.00	92.70	43.00	21.63	36.13	4.00
50	6.13	RR506	55.3	11.8	11.06	3.40	67.77	21.00	13.06	19.19	5.00
	13.13	RR5013	55.3	11.8	11.06	3.40	145.17	44.00	20.06	33.19	5.00
	20.13	RR5020	55.3	11.8	11.06	3.40	222.56	68.00	28.88	49.00	5.00
75	6.13	RR756	79.6	17.6	15.92	4.90	97.58	29.00	13.69	19.81	5.75
	13.13	RR7513	79.6	17.6	15.92	4.90	209.00	64.00	20.69	33.81	5.75
100	6.63	RR1006	103.2	48.0	20.65	9.60	136.93	63.00	14.06	20.69	7.00
	13.13	RR10013	103.2	48.0	20.65	9.60	271.17	126.00	20.63	33.75	7.00
	18.13	RR10018	103.2	48.0	20.65	9.60	374.44	174.00	27.06	45.19	7.00
150	2.25	RR1502	153.5	74.0	30.71	14.80	69.11	33.00	7.19	9.44	8.00
	6.13	RR1506	153.5	74.0	30.71	14.80	188.28	91.00	15.19	21.31	8.00
	13.13	RR15013	153.5	74.0	30.71	14.80	403.27	194.00	22.20	35.31	8.00
	32.13	RR15032	153.5	74.0	30.71	14.80	986.84	475.00	43.94	76.06	8.00
200	6.00	RR2006	221.0	112.5	44.21	22.50	265.28	135.00	16.94	22.94	9.75
	13.00	RR20013	221.0	112.5	44.21	22.50	574.78	293.00	23.94	36.94	9.75
	18.00	RR20018	221.0	112.5	44.21	22.50	795.85	396.00	30.13	48.13	9.75
	24.00	RR20024	221.0	112.5	44.21	22.50	1,061	528.00	36.13	60.13	9.75
	36.00	RR20036	221.0	112.5	44.21	22.50	1,592	792.00	48.13	84.13	9.75
	48.00	RR20048	221.0	112.5	44.21	22.50	2,122	1,056	60.13	108.13	9.75
300	6.00	RR3006	354.6	190.0	70.93	38.00	425.56	228.00	19.13	25.13	12.25
	12.00	RR30012	354.6	190.0	70.93	38.00	851.12	456.00	25.13	37.13	12.25
	18.00	RR30018	354.6	190.0	70.93	38.00	1,277	684.00	31.13	49.13	12.25
	24.00	RR30024	354.6	190.0	70.93	38.00	1,702	912.00	37.13	61.13	12.25
	36.00	RR30036	354.6	190.0	70.93	38.00	2,553	1368	49.13	85.13	12.25
	48.00	RR30048	354.6	190.0	70.93	38.00	3,405	1824	61.13	109.13	12.25
400	6.00	RR4006	475.4	255.0	95.09	51.00	570.51	306.00	21.19	27.19	14.13
	12.00	RR40012	475.4	255.0	95.09	51.00	1,141	612.00	27.19	39.19	14.13
	18.00	RR40018	475.4	255.0	95.09	51.00	1,712	918.00	33.19	51.19	14.13
	24.00	RR40024	475.4	255.0	95.09	51.00	2,282	1224	39.19	63.19	14.13
	36.00	RR40036	475.4	255.0	95.09	51.00	3,423	1836	51.19	87.19	14.13
	48.00	RR40048	475.4	255.0	95.09	51.00	4,564	2448	63.19	111.19	14.13
500	6.00	RR5006	565.7	315.0	113.15	63.00	678.92	378.00	22.75	28.75	15.63
	12.00	RR50012	565.7	315.0	113.15	63.00	1,358	756.00	28.75	40.75	15.63
	18.00	RR50018	565.7	315.0	113.15	63.00	2,037	1134	34.75	52.75	15.63
	24.00	RR50024	565.7	315.0	113.15	63.00	2,716	1512	40.75	64.75	15.63
	36.00	RR50036	565.7	315.0	113.15	63.00	4,074	2268	52.75	88.75	15.63
	48.00	RR50048	565.7	315.0	113.15	63.00	5,431	3024	64.75	112.75	15.63

*N: For RR1010 and RR1012: N = 1.26 inch; for RR308 and RR3014: N = 2.20 inch.

Double-Acting Long Stroke Cylinders

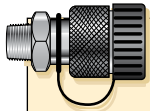

Couplers Included!
CR400 couplers included on all models. Fits all HC-Series hoses.

Capacity:
10 - 500 tons

Stroke:
2.25 - 48.00 inches

Maximum Operating Pressure:
10,000 psi

RR Series



Cylinder Bore Diameter	Plunger Diameter	Base to Adv. Port	Top to Return Port	Saddle Diameter	Saddle Protrusion from Plngr.	Plunger Internal Thread	Plunger Thread Length	Base Mounting Holes			Collar Thread	Collar Thread Length	Weight (lbs)	Model Number
								Bolt Cir. Diam.	Thread	Thread Depth				
E (in)	F (in)	H (in)	I (in)	J (in)	K (in)	O (in)	P (in)	U (in)	V (in)	Z (in)	W (in)	X (in)		
1.69	1.38	1.44	2.25	1.38	0.24	1-8	1.00	-	-	-	2 1/4-14	1.06	28	RR1010*
1.69	1.38	1.44	2.25	1.38	0.24	1-8	1.00	-	-	-	2 1/4-14	1.06	31	RR1012*
2.88	2.13	1.44	3.19	2.00	0.41	1 1/2-16	1.00	-	-	-	3 5/16-12	1.94	40	RR308*
2.88	2.13	1.56	3.19	2.00	0.41	1 1/2-16	1.00	-	-	-	3 5/16-12	1.94	64	RR3014*
3.75	3.13	1.13	3.00	2.81	0.11	1-12	1.00	-	-	-	5-12	2.00	67	RR506
3.75	3.13	1.13	3.00	2.81	0.11	1-12	1.00	-	-	-	5-12	2.00	115	RR5013
3.75	3.13	2.25	3.00	2.81	0.11	1-12	1.00	3.00	-	-	5-12	2.00	150	RR5020
4.50	3.75	1.19	3.00	2.81	0.25	1-12	1.10	-	-	-	5 3/4-12	1.97	92	RR756
4.50	3.75	1.19	3.19	2.81	0.25	1-12	1.10	-	-	-	5 3/4-12	1.97	150	RR7513
5.13	3.75	1.50	2.81	3.00	0.13	1 3/4-12	1.38	5.50	3/4-10	1.00	6 7/8-12	2.00	135	RR1006
5.13	3.75	1.50	2.81	3.00	0.13	1 3/4-12	1.38	5.50	3/4-10	1.00	6 7/8-12	2.00	205	RR10013
5.13	3.75	1.63	3.63	3.00	0.13	1 3/4-12	1.38	5.50	3/4-10	1.00	6 7/8-12	2.00	260	RR10018
6.25	4.50	0.88	2.63	3.67	0.06	-	-	-	-	-	-	-	110	RR1502
6.25	4.50	1.94	3.31	4.49	0.75	3 3/8-16	1.38	6.25	3/4-16	1.00	8-12	2.36	205	RR1506
6.25	4.50	1.94	3.31	4.49	0.75	3 3/8-16	1.38	6.25	3/4-16	1.00	8-12	2.36	275	RR15013
6.25	4.50	3.31	3.31	4.49	0.75	3 3/8-16	1.38	-	-	-	8-12	2.36	525	RR15032
7.50	5.25	2.25	3.81	5.25	0.88	-	-	5.00	1-8	1.00	-	-	325	RR2006
7.50	5.25	2.25	3.81	5.25	0.88	2 1/2-12	2.50	5.00	1-8	1.00	9 3/4-12	2.13	440	RR20013
7.50	5.25	3.38	4.00	5.25	0.88	2 1/2-12	2.50	5.00	1-8	1.00	9 3/4-12	2.13	450	RR20018
7.50	5.25	3.38	4.00	5.25	0.88	2 1/2-12	2.50	5.00	1-8	1.00	9 3/4-12	2.13	616	RR20024
7.50	5.25	3.38	4.00	5.25	0.88	2 1/2-12	2.50	5.00	1-8	1.00	9 3/4-12	2.13	845	RR20036
7.50	5.25	3.38	4.00	5.25	0.88	2 1/2-12	2.50	5.00	1-8	1.00	9 3/4-12	2.13	1065	RR20048
9.50	6.50	3.50	4.50	6.50	1.13	2 1/2-12	3.25	6.25	1 1/4-7	1.75	12 1/4-12	2.31	441	RR3006
9.50	6.50	3.50	4.50	6.50	1.13	2 1/2-12	3.25	6.25	1 1/4-7	1.75	12 1/4-12	2.31	608	RR30012
9.50	6.50	3.50	4.50	6.50	1.13	2 1/2-12	3.25	6.25	1 1/4-7	1.75	12 1/4-12	2.31	776	RR30018
9.50	6.50	3.50	4.50	6.50	1.13	2 1/2-12	3.25	6.25	1 1/4-7	1.75	12 1/4-12	2.31	1034	RR30024
9.50	6.50	3.50	4.50	6.50	1.13	2 1/2-12	3.25	6.25	1 1/4-7	1.75	12 1/4-12	2.31	1385	RR30036
9.50	6.50	3.50	4.50	6.50	1.13	2 1/2-12	3.25	6.25	1 1/4-7	1.75	12 1/4-12	2.31	1720	RR30048
11.00	7.50	4.25	5.25	7.50	1.13	3-12	3.75	8.00	1 1/2-6	2.00	14 1/8-8	2.56	670	RR4006
11.00	7.50	4.25	5.25	7.50	1.13	3-12	3.75	8.00	1 1/2-6	2.00	14 1/8-8	2.56	880	RR40012
11.00	7.50	4.25	5.25	7.50	1.13	3-12	3.75	8.00	1 1/2-6	2.00	14 1/8-8	2.56	1000	RR40018
11.00	7.50	4.25	5.25	7.50	1.13	3-12	3.75	8.00	1 1/2-6	2.00	14 1/8-8	2.56	1317	RR40024
11.00	7.50	4.25	5.25	7.50	1.13	3-12	3.75	8.00	1 1/2-6	2.00	14 1/8-8	2.56	1746	RR40036
11.00	7.50	4.25	5.25	7.50	1.13	3-12	3.75	8.00	1 1/2-6	2.00	14 1/8-8	2.56	2162	RR40048
12.00	8.00	4.75	6.00	8.00	1.13	3 1/4-12	4.25	8.00	1 3/4-5	2.12	15 5/8-8	3.13	953	RR5006
12.00	8.00	4.75	6.00	8.00	1.13	3 1/4-12	4.25	8.00	1 3/4-5	2.12	15 5/8-8	3.13	1300	RR50012
12.00	8.00	4.75	6.00	8.00	1.13	3 1/4-12	4.25	8.00	1 3/4-5	2.12	15 5/8-8	3.13	1500	RR50018
12.00	8.00	4.75	6.00	8.00	1.13	3 1/4-12	4.25	8.00	1 3/4-5	2.12	15 5/8-8	3.13	1800	RR50024
12.00	8.00	4.75	6.00	8.00	1.13	3 1/4-12	4.25	8.00	1 3/4-5	2.12	15 5/8-8	3.13	2210	RR50036
12.00	8.00	4.75	6.00	8.00	1.13	3 1/4-12	4.25	8.00	1 3/4-5	2.12	15 5/8-8	3.13	2700	RR50048

▼ HCL1006, HCG2006, HCR506



Highest Level of Durability



The Summit Edition

Innovation is at the heart of the new *Summit Edition* of cylinders, delivering the high quality construction that you expect from Enerpac. The durability ensures your job gets done safely and reliably.

- Plunger support bearing adds support for eccentric loads ²⁾
- Nitrocarburization surface treatment for improved wear resistance and corrosion protection
- Replaceable composite bearings surround the seal providing support for eccentric loads
- Low-wear, high-pressure seals provide longer service life

²⁾ Eccentric load (or “side-load”) is inevitable in heavy lifting. Our unique Summit Edition features provide the ultimate protection against side-load. Increased bearing surface maintains stability, and nitrocarburization treatment prevents scoring on the inside of the cylinder. Side-load poses a real problem.... our new cylinder features are the solution!

Reaching the Summit Edition:

- Nitrocarburized hardened surfaces offers improved protection against side-load scoring and cyclic wear
- Weather protected, inside and out
- Low-friction locking rings spin easy, save time and effort ¹⁾

Enclosed polymer bearing system

- Upper and lower bearings enclose the cylinder plunger for support and are able to be replaced along with seals and other soft parts
- State-of-the-art bearing materials reduce wear and avoid bore damage even in high side-load conditions

Low-wear, high-pressure seals

- Improved geometry and material selection increases seal performance even in harsh conditions
- Low friction improves retraction times

Versatile

- Over 220 models in five configurations ¹⁾
- Certified lifting eyes, base mounting holes and collar threads are included for secure handling and cylinder mounting ¹⁾

¹⁾ See specific model's technical data for more information.

▼ *Bridge lifting and launching system. The load is balanced on groups of lock nut cylinders. The hydraulic movements are synchronized using the Enerpac PLC-controlled synchronous lift systems.*





High-Tonnage Cylinders

The Enerpac High-Tonnage Cylinders are particularly suitable for (multipoint) lifting applications.

HCG, HCR, HCL, HCRL-Series Cylinders

- 50 - 1000-ton lifting capacity
- 1.97 - 11.81 inch lifting stroke
- Designed to withstand up to 10% side-load of maximum capacity

HCG-Series - Single-Acting

- Load return
- Stop-ring to prevent plunger blow-out

HCR-Series - Double-Acting

- Hydraulic advance and retract for controlled movement

HCL-Series - Lock Nut, Single-Acting

- Load return
- Lock nut for mechanical load holding
- Overflow port to prevent plunger blow out

HCRL-Series - Lock Nut, Double-Acting

- 50 - 300 ton lifting capacity
- 5.91 - 11.81 inch stroke
- Hydraulic advance and retract
- Integrated tilt saddle
- Lock nut for mechanical load holding

LPL-Series - Lock Nut, Low-Height, Single-Acting

- 60 - 500 ton lifting capacity
- 1.77 - 1.97 inch lifting stroke
- Integrated tilt saddle
- Load return
- Lock nut for mechanical load holding
- 5-10% side-load of maximum capacity

In combination with our state-of-the-art power packs, you will have a world class hydraulic system to perform the most challenging lifting jobs in a safe and professional manner.

Page: 44

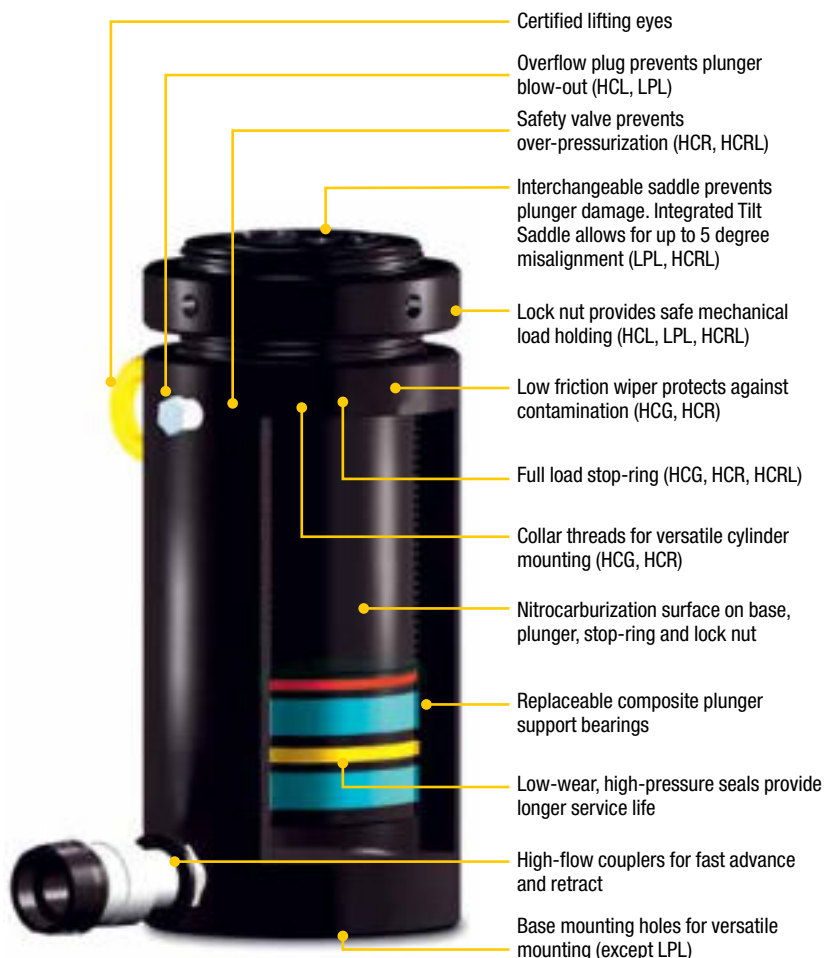

HCG HCR HCL HCRL Series



Capacity:

50 - 1000 ton

Stroke:

1.97 - 11.81 inches

Maximum Operating Pressure:

10,150 psi



Assisted-Return Pumps

Enerpac HCG, HCL and LPL-Series cylinders are hydraulic advance and load return. To improve

productivity and plunger retraction Enerpac offers assisted return on ZU4 and ZE-Series pumps featuring Enerpac Venturi valve technology, specifically to facilitate the faster return of single-acting, load return cylinders. See enerpac.com for details.



Split-Flow Pumps

SFP-Series pumps with multiple outlets with equal oil flow. For lifting and lowering applications on multiple points, these pumps are a far better alternative than using separately operated pumps.

Page: 132



EVO-Series, Synchronous Lifting Systems

The EVO-system is the safest system for multi-point lifting, provided synchronized control over lifting stroke with a wide variety of features and functions.

Page: 136



QUICK SELECTION

Cylinder Capacity (ton)	Stroke (in)	Maximum Cylinder Capacity at 10,150 psi (ton)	HCG-Series		HCR-Series		HCL-Series		HCRL-Series*	
			Model Number Single-Acting <i>Page: 48</i>	Collapsed Height (in)	Model Number Double-Acting <i>Page: 52</i>	Collapsed Height (in)	Model No. Single-Acting with Lock Nut <i>Page: 56</i>	Collapsed Height (in)	Model No. Double-Acting with Lock Nut <i>Page: 60</i>	Collapsed Height (in)
50	1.97	62	HCG502	7.20	HCR502	7.20	HCL502	6.46	—	—
	3.94		HCG504	9.17	HCR504	9.17	HCL504	8.43	—	—
	5.91		HCG506	11.14	HCR506	11.14	HCL506	10.39	HCRL506	12.20
	7.87		HCG508	13.62	HCR508	13.62	HCL508	12.36	HCRL508	14.84
	9.84		HCG5010	15.59	HCR5010	15.59	HCL5010	14.33	HCRL5010	16.81
	11.81		HCG5012	17.56	HCR5012	17.56	HCL5012	16.30	HCRL5012	18.77
100	1.97	113	HCG1002	7.95	HCR1002	7.95	HCL1002	7.36	—	—
	3.94		HCG1004	9.92	HCR1004	9.92	HCL1004	9.33	—	—
	5.91		HCG1006	11.89	HCR1006	11.89	HCL1006	11.30	HCRL1006	13.62
	7.87		HCG1008	14.92	HCR1008	14.92	HCL1008	13.27	HCRL1008	16.57
	9.84		HCG10010	16.89	HCR10010	16.89	HCL10010	15.24	HCRL10010	18.54
	11.81		HCG10012	18.86	HCR10012	18.86	HCL10012	17.20	HCRL10012	20.51
150	1.97	168	HCG1502	8.66	HCR1502	8.66	HCL1502	8.23	—	—
	3.94		HCG1504	10.63	HCR1504	10.63	HCL1504	10.20	—	—
	5.91		HCG1506	12.60	HCR1506	12.60	HCL1506	12.17	HCRL1506	14.13
	7.87		HCG1508	15.63	HCR1508	15.63	HCL1508	14.13	HCRL1508	17.09
	9.84		HCG15010	17.60	HCR15010	17.60	HCL15010	16.10	HCRL15010	19.06
	11.81		HCG15012	19.57	HCR15012	19.57	HCL15012	18.07	HCRL15012	21.02
200	1.97	223	HCG2002	9.09	HCR2002	9.09	HCL2002	9.37	—	—
	3.94		HCG2004	11.06	HCR2004	11.06	HCL2004	11.34	—	—
	5.91		HCG2006	13.03	HCR2006	13.03	HCL2006	13.31	HCRL2006	15.70
	7.87		HCG2008	16.06	HCR2008	16.06	HCL2008	15.28	HCRL2008	18.46
	9.84		HCG20010	18.03	HCR20010	18.03	HCL20010	17.24	HCRL20010	20.43
	11.81		HCG20012	20.00	HCR20012	20.00	HCL20012	19.21	HCRL20012	22.40
250	1.97	286	HCG2502	9.49	HCR2502	9.49	HCL2502	9.80	—	—
	3.94		HCG2504	11.46	HCR2504	11.46	HCL2504	11.77	—	—
	5.91		HCG2506	13.43	HCR2506	13.43	HCL2506	13.74	HCRL2506	16.38
	7.87		HCG2508	16.97	HCR2508	16.97	HCL2508	15.71	HCRL2508	19.33
	9.84		HCG25010	18.94	HCR25010	18.94	HCL25010	17.68	HCRL25010	21.30
	11.81		HCG25012	20.91	HCR25012	20.91	HCL25012	19.65	HCRL25012	23.27
300	1.97	341	HCG3002	11.65	HCR3002	11.65	HCL3002	10.94	—	—
	3.94		HCG3004	13.62	HCR3004	13.62	HCL3004	12.91	—	—
	5.91		HCG3006	15.59	HCR3006	15.59	HCL3006	14.88	HCRL3006	16.57
	7.87		HCG3008	17.56	HCR3008	17.56	HCL3008	16.85	HCRL3008	19.53
	9.84		HCG30010	19.53	HCR30010	19.53	HCL30010	18.82	HCRL30010	21.50
	11.81		HCG30012	21.50	HCR30012	21.50	HCL30012	20.79	HCRL30012	23.46

* The HCRL-Series Cylinders are available up to 2000-ton and additional stroke lengths available on request.

Enerpac High-Tonnage Cylinders

Capacity:
50 - 1000 ton

Stroke:
1.97 - 11.81 inches

Maximum Operating Pressure:
10,150 psi

**HCG
HCR
HCL
HCRL**
Series



QUICK SELECTION

QUICK SELECTION			HCG-Series		HCR-Series		HCL-Series	
Cylinder Capacity (ton)	Stroke (in)	Maximum Cylinder Capacity at 10,150 psi (ton)	Model Number Single-Acting <i>Page: 48</i>	Collapsed Height (in)	Model Number Double-Acting <i>Page: 52</i>	Collapsed Height (in)	Model Number Single-Acting With Lock Nut <i>Page: 56</i>	Collapsed Height (in)
400	1.97	450	HCG4002	12.64	HCR4002	12.64	HCL4002	12.48
	3.94		HCG4004	14.61	HCR4004	14.61	HCL4004	14.45
	5.91		HCG4006	16.57	HCR4006	16.57	HCL4006	16.42
	7.87		HCG4008	18.54	HCR4008	18.54	HCL4008	18.39
	9.84		HCG40010	20.51	HCR40010	20.51	HCL40010	20.35
	11.81		HCG40012	22.48	HCR40012	22.48	HCL40012	22.32
500	1.97	575	HCG5002	13.54	HCR5002	13.54	HCL5002	14.06
	3.94		HCG5004	15.51	HCR5004	15.51	HCL5004	16.02
	5.91		HCG5006	17.48	HCR5006	17.48	HCL5006	17.99
	7.87		HCG5008	19.45	HCR5008	19.45	HCL5008	19.96
	9.84		HCG50010	21.42	HCR50010	21.42	HCL50010	21.93
	11.81		HCG50012	23.39	HCR50012	23.39	HCL50012	23.90
600	1.97	673	HCG6002	13.86	HCR6002	13.86	HCL6002	14.96
	3.94		HCG6004	15.83	HCR6004	15.83	HCL6004	16.93
	5.91		HCG6006	17.80	HCR6006	17.80	HCL6006	18.90
	7.87		HCG6008	19.76	HCR6008	19.76	HCL6008	20.87
	9.84		HCG60010	21.73	HCR60010	21.73	HCL60010	22.83
	11.81		HCG60012	23.70	HCR60012	23.70	HCL60012	24.80
800	1.97	916	HCG8002	15.91	HCR8002	15.91	HCL8002	16.93
	3.94		HCG8004	17.87	HCR8004	17.87	HCL8004	18.90
	5.91		HCG8006	19.84	HCR8006	19.84	HCL8006	20.87
	7.87		HCG8008	21.81	HCR8008	21.81	HCL8008	22.83
	9.84		HCG80010	23.78	HCR80010	23.78	HCL80010	24.80
	11.81		HCG80012	25.75	HCR80012	25.75	HCL80012	26.77
1000	1.97	1196	HCG10002	17.40	HCR10002	17.40	HCL10002	19.06
	3.94		HCG10004	19.37	HCR10004	19.37	HCL10004	21.02
	5.91		HCG10006	21.34	HCR10006	21.34	HCL10006	22.99
	7.87		HCG10008	23.31	HCR10008	23.31	HCL10008	24.96
	9.84		HCG100010	25.28	HCR100010	25.28	HCL100010	26.93
	11.81		HCG100012	27.24	HCR100012	27.24	HCL100012	28.90

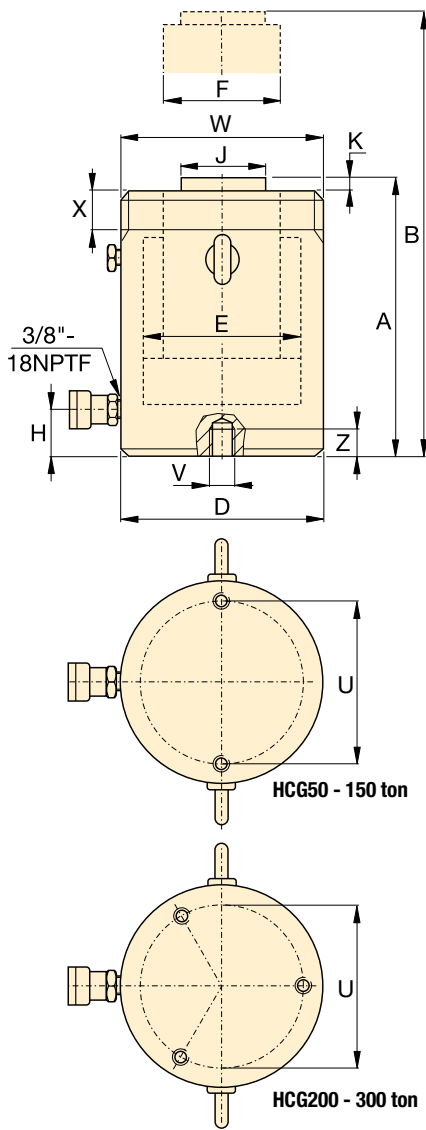

HCG-Series, Single-Acting, Load Return Cylinders

- Hardened surface resists side-loading and cyclic wear
- Designed to withstand up to 10% side-load of maximum capacity ¹⁾
- Stop-ring to prevent plunger blow-out
- Weather protected, inside and out
- Upper and lower replaceable bearings enclose the cylinder plunger for support throughout the stroke
- Certified lifting eyes, base mounting holes and collar threads
- Standard collar thread up to 250 ton models. Collar thread is optional on 300 ton models and higher

SELECTION CHART 50 – 300-TON HCG-MODELS

For 400 – 1000-ton models, see pages 50-51.

For full product features see pages 44-45.

Cylinder Capacity (ton)	Stroke (in)	Model Number	Maximum Cylinder Capacity at 10,150 psi (ton)	Cylinder Effective Area (in ²)	Oil Capacity (in ³)	Collapsed Height A (in)
50	1.97	HCG502	62	12.17	23.96	7.20
	3.94	HCG504			47.93	9.17
	5.91	HCG506 ¹⁾			71.89	11.14
	7.87	HCG508			95.86	13.62
	9.84	HCG5010			119.82	15.59
	11.81	HCG5012 ¹⁾			143.78	17.56
100	1.97	HCG1002	113	22.19	43.67	7.95
	3.94	HCG1004			87.35	9.92
	5.91	HCG1006			131.02	11.89
	7.87	HCG1008			174.70	14.92
	9.84	HCG10010			218.37	16.89
	11.81	HCG10012			262.05	18.86
150	1.97	HCG1502	168	33.14	65.24	8.66
	3.94	HCG1504			130.48	10.63
	5.91	HCG1506			195.73	12.60
	7.87	HCG1508			260.97	15.63
	9.84	HCG15010			326.21	17.60
	11.81	HCG15012			391.45	19.57
200	1.97	HCG2002	223	43.95	86.51	9.09
	3.94	HCG2004			173.02	11.06
	5.91	HCG2006			259.53	13.03
	7.87	HCG2008			346.04	16.06
	9.84	HCG20010			432.55	18.03
	11.81	HCG20012			519.06	20.00
250	1.97	HCG2502	286	56.27	110.77	9.49
	3.94	HCG2504			221.55	11.46
	5.91	HCG2506			332.32	13.43
	7.87	HCG2508			443.09	16.97
	9.84	HCG25010			553.87	18.94
	11.81	HCG25012			664.64	20.91
300	1.97	HCG3002	341	67.23	132.34	11.65
	3.94	HCG3004			264.68	13.62
	5.91	HCG3006			397.02	15.59
	7.87	HCG3008			529.36	17.56
	9.84	HCG30010			661.71	19.53
	11.81	HCG30012			794.05	21.50

Collar Thread* (in)		
Model / Capacity (ton)	Thread Size W	Thread Length X
HCG50	M130 x 2	1.18
HCG100	M175 x 3	1.81
HCG150	M215 x 3	2.17
HCG200	M250 x 3	2.48
HCG250	M280 x 3	2.52
HCG300*	M305 x 3	2.87

* Standard collar thread up to 250 ton models. Collar thread is optional on 300 ton models and higher. For collar thread on cylinder add suffix "E002" to model number. Example: **HCG3006E002**. The collar thread length is designed for the full rated cylinder capacity.

Base Mounting Holes (in)					
Model / Capacity (ton)	Bolt Circle U	Thread Size V	Minimum Thread Depth Z	Number of Holes	Angle from Coupler
HCG50	4.13	M12 x 1,75	0.87	2	90°
HCG100	5.91	M12 x 1,75	0.87	2	90°
HCG150	7.28	M12 x 1,75	0.87	2	90°
HCG200	8.46	M12 x 1,75	0.87	3	60°
HCG250	9.65	M12 x 1,75	0.87	3	60°
HCG300	10.24	M16 x 2	0.98	3	60°

¹⁾ HCG506 and HCG5012: 7% side-load of maximum capacity.

Single-Acting, High-Tonnage Cylinders

Capacity:
50 - 300 ton

Stroke:
1.97 - 11.81 inches

Maximum Operating Pressure:
10,150 psi

HCG Series

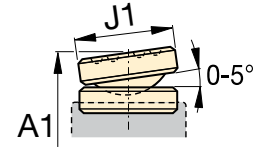

CATS-Series Tilt Saddle

	Extended Height	Outside Diameter	Cylinder Bore Diameter	Plunger Diameter	Base to Advance Port	Standard Saddle Diameter	Saddle Protrusion from Plunger	Weight	Model Number
	B (in)	D (in)	E (in)	F (in)	H (in)	J (in)	K (in)	(lbs)	
	9.17	5.12	3.94	2.76	1.50	1.97	0.12	37	HCG502
	13.11							45	HCG504
	17.05							53	HCG506 1)
	21.50							64	HCG508
	25.43							72	HCG5010
	29.37							80	HCG5012 1)
	9.92	6.89	5.31	3.74	1.50	2.95	0.12	73	HCG1002
	13.86							88	HCG1004
	17.80							102	HCG1006
	22.80							128	HCG1008
	26.73							142	HCG10010
	30.67							157	HCG10012 1)
	10.63	8.46	6.50	4.72	1.61	3.70	0.12	123	HCG1502
	14.57							145	HCG1504
	18.50							168	HCG1506
	23.50							207	HCG1508
	27.44							230	HCG15010
	31.38							253	HCG15012
	11.06	9.84	7.48	5.51	1.85	4.45	0.12	178	HCG2002
	15.00							209	HCG2004
	18.94							240	HCG2006
	23.94							300	HCG2008
	27.87							331	HCG20010
	31.81							363	HCG20012
	11.46	11.02	8.46	6.69	2.09	5.51	0.16	235	HCG2502
	15.39							277	HCG2504
	19.33							318	HCG2506
	24.84							401	HCG2508
	28.78							442	HCG25010
	32.72							484	HCG25012
	13.62	12.01	9.25	7.87	2.28	5.51	0.16	348	HCG3002
	17.56							401	HCG3004
	21.50							454	HCG3006
	25.43							507	HCG3008
	29.37							560	HCG30010
	33.31							613	HCG30012

Optional Tilt Saddle		
Saddle Diameter J1 (in)	Collap. Height* A1 (in)	Saddle Model Number
2.80	7.75	CATS50
	9.72	
	11.69	
	14.17	
	16.14	
	18.11	
2.80	8.35	CATS101
	10.31	
	12.28	
	15.31	
	17.28	
	19.25	
3.82	9.41	CATS150
	11.38	
	13.35	
	16.38	
	18.35	
	20.31	
4.96	9.80	CATS200
	11.77	
	13.74	
	16.77	
	18.74	
	20.71	
6.89	11.00	CATS300
	13.00	
	14.96	
	18.50	
	20.47	
	22.44	
6.89	13.19	CATS300
	15.16	
	17.13	
	19.00	
	21.00	
	23.00	

* A1 = Collapsed height including CATS-Series tilt saddle.

HCG-Series, Single-Acting, Load Return Cylinders

- Hardened surface resists side-loading and cyclic wear
- Designed to withstand up to 10% side-load of maximum capacity
- Stop-ring to prevent plunger blow-out
- Weather protected, inside and out
- Upper and lower replaceable bearings enclose the cylinder plunger for support throughout the stroke
- Certified lifting eyes, base mounting holes and collar threads
- Optional collar threads on 300 ton models and higher capacities

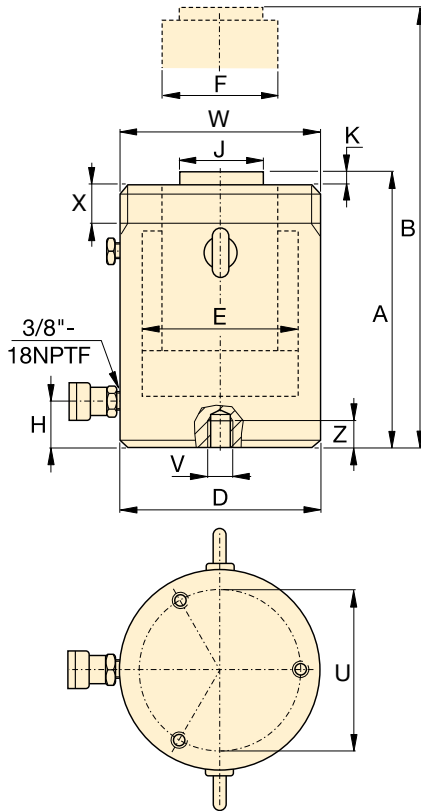

SELECTION CHART 400 – 1000-TON HCG-MODELS

For 50 – 300-ton models, see pages 48-49.

For full product features see pages 44-45.

Cylinder Capacity (ton)	Stroke (in)	Model Number	Maximum Cylinder Capacity at 10,150 psi (ton)	Cylinder Effective Area (in ²)	Oil Capacity (in ³)	Collapsed Height A (in)
400	1.97	HCG4002	450	88.75	174.70	12.64
	3.94	HCG4004			349.39	14.61
	5.91	HCG4006			524.09	16.57
	7.87	HCG4008			698.79	18.54
	9.84	HCG40010			873.49	20.51
	11.81	HCG40012			1,048.18	22.48
500	1.97	HCG5002	575	113.25	222.92	13.54
	3.94	HCG5004			445.85	15.51
	5.91	HCG5006			668.77	17.48
	7.87	HCG5008			891.70	19.45
	9.84	HCG50010			1,114.62	21.42
	11.81	HCG50012			1,337.55	23.39
600	1.97	HCG6002	673	132.57	260.97	13.86
	3.94	HCG6004			521.94	15.83
	5.91	HCG6006			782.90	17.80
	7.87	HCG6008			1,043.87	19.76
	9.84	HCG60010			1,304.84	21.73
	11.81	HCG60012			1,565.81	23.70
800	1.97	HCG8002	916	180.44	355.21	15.91
	3.94	HCG8004			710.41	17.87
	5.91	HCG8006			1,065.62	19.84
	7.87	HCG8008			1,420.82	21.81
	9.84	HCG80010			1,776.03	23.78
	11.81	HCG80012			2,131.24	25.75
1000	1.97	HCG10002	1196	235.68	463.94	17.40
	3.94	HCG10004			927.88	19.37
	5.91	HCG10006			1,391.83	21.34
	7.87	HCG10008			1,855.77	23.31
	9.84	HCG100010			2,319.71	25.28
	11.81	HCG100012			2,783.65	27.24

Collar Thread (in)		
Model / Capacity (ton)	Thread Size W	Thread Length X
HCG400	M350 x 3	3.27
HCG500	M400 x 4	3.54
HCG600	M430 x 4	3.94
HCG800	M505 x 5	4.80
HCG1000	M570 x 5	5.39

Collar thread is optional on 300 ton models and higher. For collar thread on cylinder add suffix "E002" to model number. Example: **HCG4006E002**. The collar thread length is designed for the full rated cylinder capacity.

Base Mounting Holes (in)					
Model / Capacity (ton)	Bolt Circle U	Thread Size V	Minimum Thread Depth Z	Number of Holes	Angle from Coupler
HCG400	11.81	M16 x 2	0.98	3	60°
HCG500	13.39	M24 x 3	1.42	3	60°
HCG600	14.57	M24 x 3	1.42	3	60°
HCG800	17.32	M24 x 3	1.42	3	60°
HCG1000	19.69	M24 x 3	1.42	3	60°

Single-Acting, High-Tonnage Cylinders



▲ Offshore wind turbine leveling: Enerpac's synchronous lifting system was the solution for leveling support cross pieces on 80 wind turbines.

HCG Series



Capacity:
400 - 1000 ton

Stroke:
1.97 - 11.81 inches

Maximum Operating Pressure:
10,150 psi

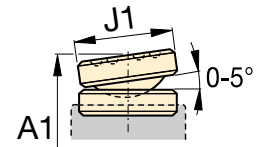

CATS-Series Tilt Saddle

Extended Height	Outside Diameter	Cylinder Bore Diameter	Plunger Diameter	Base to Advance Port	Standard Saddle Diameter	Saddle Protrusion from Plunger	Weight	Model Number
B (in)	D (in)	E (in)	F (in)	H (in)	J (in)	K (in)	(lbs)	
14.61	13.78	10.63	8.66	2.91	6.26	0.16	500	HCG4002
18.54							566	HCG4004
22.48							633	HCG4006
26.42							699	HCG4008
30.35							766	HCG40010
34.29							833	HCG40012
15.51	15.75	12.01	9.84	3.11	7.05	0.16	704	HCG5002
19.45							792	HCG5004
23.39							880	HCG5006
27.32							968	HCG5008
31.26							1,056	HCG50010
35.20							1,144	HCG50012
15.83	16.93	12.99	10.63	3.35	7.64	0.16	834	HCG6002
19.76							935	HCG6004
23.70							1,036	HCG6006
27.64							1,137	HCG6008
31.57							1,239	HCG60010
35.51							1,340	HCG60012
17.87	19.88	15.16	12.60	3.94	8.82	0.16	1,336	HCG8002
21.81							1,479	HCG8004
25.75							1,621	HCG8006
29.69							1,763	HCG8008
33.62							1,905	HCG80010
37.56							2,047	HCG80012
19.37	22.44	17.32	13.39	4.49	9.80	0.16	1,852	HCG10002
23.31							2,020	HCG10004
27.24							2,188	HCG10006
31.18							2,355	HCG10008
35.12							2,523	HCG100010
39.06							2,691	HCG100012

Optional Tilt Saddle		
Saddle Diameter J1 (in)	Collap. Height* A1 (in)	Saddle Model Number
8.27	14.53	CATS400
	16.50	
	18.46	
	20.43	
	22.40	
	24.37	
9.06	15.43	CATS500
	17.40	
	19.37	
	21.34	
	23.31	
	25.28	
9.84	15.94	CATS600
	17.91	
	19.88	
	21.85	
	23.82	
	25.79	
10.83	18.15	CATG800
	20.12	
	22.00	
	24.00	
	26.00	
	28.00	
11.81	20.43	CATS1000
	22.40	
	24.37	
	26.34	
	28.31	
	30.28	

* A1 = Collapsed height including CATS-Series tilt saddle..

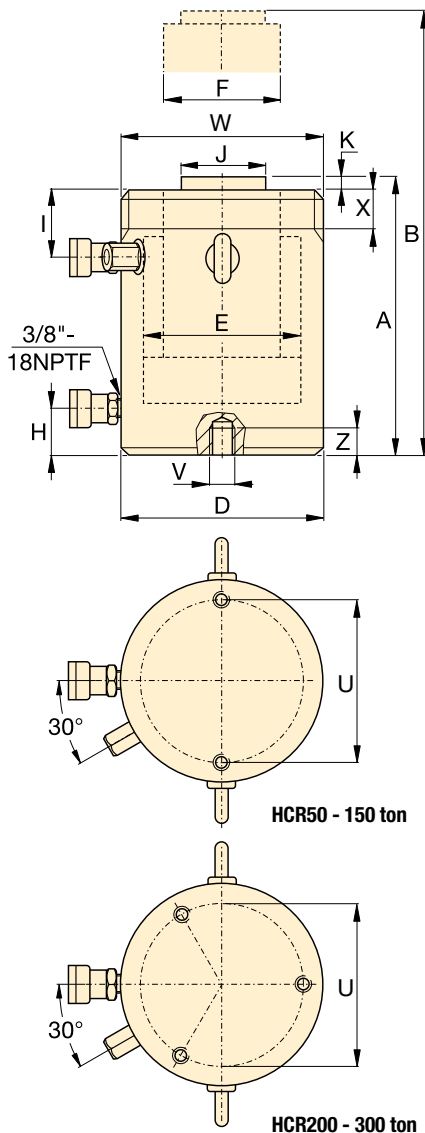

HCR-Series, Double-Acting Cylinders

- Fast advance and retract
- Designed to withstand up to 10% side-load of maximum capacity ¹⁾
- Hardened surface resists side-loading and cyclic wear
- Weather protected, inside and out
- Upper and lower replaceable bearings enclose the cylinder plunger for support throughout the stroke
- Certified lifting eyes, base mounting holes and collar threads
- Standard collar thread up to 250 ton models. Collar thread is optional on 300 ton models and higher

SELECTION CHART AND DETAILS OF 50 – 300-TON HCR-MODELS

For 400 – 1000-ton models, see pages 54-55.

For full product features see pages 44-45

Cylinder Capacity (ton)	Stroke (in)	Model Number	Maximum Cylinder Capacity at 10,150 psi (ton)	Cylinder Effective Area (in ²)	Oil Capacity (in ³)		Collapsed Height A (in)
					Advance	Retract	
50	1.97	HCR502	62	12.17	23.96	12.22	7.20
	3.94	HCR504			47.93	24.44	9.17
	5.91	HCR506 ¹⁾			71.89	36.66	11.14
	7.87	HCR508			95.86	48.89	13.62
	9.84	HCR5010			119.82	61.11	15.59
	11.81	HCR5012 ¹⁾			143.78	73.33	17.56
100	1.97	HCR1002	113	22.19	43.67	22.05	7.95
	3.94	HCR1004			87.35	44.09	9.92
	5.91	HCR1006			131.02	66.14	11.89
	7.87	HCR1008			174.70	88.19	14.92
	9.84	HCR10010			218.37	110.23	16.89
	11.81	HCR10012			262.05	132.28	18.86
150	1.97	HCR1502	168	33.14	65.24	30.73	8.66
	3.94	HCR1504			130.48	61.47	10.63
	5.91	HCR1506			195.73	92.20	12.60
	7.87	HCR1508			260.97	122.94	15.63
	9.84	HCR15010			326.21	153.67	17.60
	11.81	HCR15012			391.45	184.40	19.57
200	1.97	HCR2002	223	43.95	86.51	39.54	9.09
	3.94	HCR2004			173.02	79.08	11.06
	5.91	HCR2006			259.53	118.62	13.03
	7.87	HCR2008			346.04	158.16	16.06
	9.84	HCR20010			432.55	197.70	18.03
	11.81	HCR20012			519.06	237.24	20.00
250	1.97	HCR2502	286	56.27	110.77	41.52	9.49
	3.94	HCR2504			221.55	83.04	11.46
	5.91	HCR2506			332.32	124.55	13.43
	7.87	HCR2508			443.09	166.07	16.97
	9.84	HCR25010			553.87	207.59	18.94
	11.81	HCR25012			664.64	249.11	20.91
300	1.97	HCR3002	341	67.23	132.34	36.49	11.65
	3.94	HCR3004			264.68	72.97	13.62
	5.91	HCR3006			397.02	109.46	15.59
	7.87	HCR3008			529.36	145.94	17.56
	9.84	HCR30010			661.71	182.43	19.53
	11.81	HCR30012			794.05	218.91	21.50

Collar Thread* (in)		
Model / Capacity (ton)	Thread Size W	Thread Length X
HCR50	M130 x 2	1.18
HCR100	M175 x 3	1.81
HCR150	M215 x 3	2.17
HCR200	M250 x 3	2.48
HCR250	M280 x 3	2.52
HCR300*	M305 x 3	2.87

* Standard collar thread up to 250 ton models. Collar thread is optional on 300 ton models and higher. For collar thread on cylinder add suffix "E002" to model number. Example: **HCR3006E002**. The collar thread length is designed for the full rated cylinder capacity.

Base Mounting Holes (in)					
Model / Capacity (ton)	Bolt Circle U	Thread Size V	Minimum Thread Depth Z	No. of Holes	Angle from Coupler
HCR50	4.13	M12 x 1,75	0.87	2	90°
HCR100	5.91	M12 x 1,75	0.87	2	90°
HCR150	7.28	M12 x 1,75	0.87	2	90°
HCR200	8.46	M12 x 1,75	0.87	3	60°
HCR250	9.65	M12 x 1,75	0.87	3	60°
HCR300	10.24	M16 x 2	0.98	3	60°

¹⁾ HCR506 and HCR5012: 7% side-load of maximum capacity.

Double-Acting, High-Tonnage Cylinders

Capacity:
50 - 300 ton

Stroke:
1.97 - 11.81 inches

Maximum Operating Pressure:
10,150 psi

HCR Series

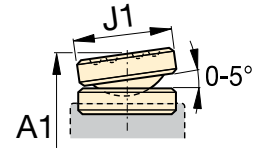

CATS-Series Tilt Saddle

	Extended Height	Outside Diameter	Cylinder Bore Diameter	Plunger Diameter	Base to Advance Port	Top to Retract Port	Standard Saddle Diameter	Saddle Protrusion from Plunger	Retract Oil Volume	Weight	Model Number	Optional Tilt Saddle		
												Saddle Diameter J1 (in)	Collap. Height* A1 (in)	Saddle Model Number
	9.17	5.12	3.94	2.76	1.50	1.77	1.97	0.12	12.22	37	HCR502	2.80	7.75	CATS50
	13.11								24.44	46	HCR504		9.72	
	17.05								36.66	54	HCR506 ¹⁾		11.69	
	21.50					48.89			68	HCR508	14.17			
	25.43					61.11			76	HCR5010	16.14			
	29.37					73.33			84	HCR5012 ¹⁾	18.11			
	9.92	6.89	5.31	3.74	1.50	2.56	2.95	0.12	22.05	74	HCR1002	2.80	8.35	CATS101
	13.86								44.09	90	HCR1004		10.31	
	17.80								66.14	105	HCR1006		12.28	
	22.80					88.19			131	HCR1008	15.31			
	26.73					110.23			146	HCR10010	17.28			
	30.67					132.28			161	HCR10012	19.25			
	10.63	8.46	6.50	4.72	1.61	2.76	3.70	0.12	30.73	124	HCR1502	3.82	9.41	CATS150
	14.57								61.47	148	HCR1504		11.38	
	18.50								92.20	172	HCR1506		13.35	
	23.50					122.94			209	HCR1508	16.38			
	27.44					153.67			233	HCR15010	18.35			
	31.38					184.40			257	HCR15012	20.31			
	11.06	9.84	7.48	5.51	1.85	3.11	4.45	0.12	39.54	179	HCR2002	4.96	9.80	CATS200
	15.00								79.08	212	HCR2004		11.77	
	18.94								118.62	244	HCR2006		13.74	
	23.94					158.16			306	HCR2008	16.77			
	27.87					197.70			338	HCR20010	18.74			
	31.81					237.24			371	HCR20012	20.71			
	11.46	11.02	8.46	6.69	2.09	3.11	5.51	0.16	41.52	236	HCR2502	6.89	11.00	CATS300
	15.39								83.04	279	HCR2504		13.00	
	19.33								124.55	322	HCR2506		14.96	
	24.84					166.07			407	HCR2508	18.50			
	28.78					207.59			457	HCR25010	20.47			
	32.72					249.11			500	HCR25012	22.44			
	13.62	12.01	9.25	7.87	2.28	3.98	5.51	0.16	36.49	350	HCR3002	6.89	13.19	CATS300
	17.56								72.97	404	HCR3004		15.16	
	21.50								109.46	458	HCR3006		17.13	
	25.43								145.94	512	HCR3008		19.00	
	29.37								182.43	566	HCR30010		21.00	
	33.31								218.91	620	HCR30012		23.00	

* A1 = Collapsed height including CATS-Series tilt saddle.

HCR-Series, Double-Acting Cylinders

- Fast advance and retract
- Designed to withstand up to 10% side-load of maximum capacity
- Hardened surface resists side-loading and cyclic wear
- Weather protected, inside and out
- Upper and lower replaceable bearings enclose the cylinder plunger for support throughout the stroke
- Certified lifting eyes, base mounting holes and collar threads
- Optional collar threads on 300 ton models and higher capacities

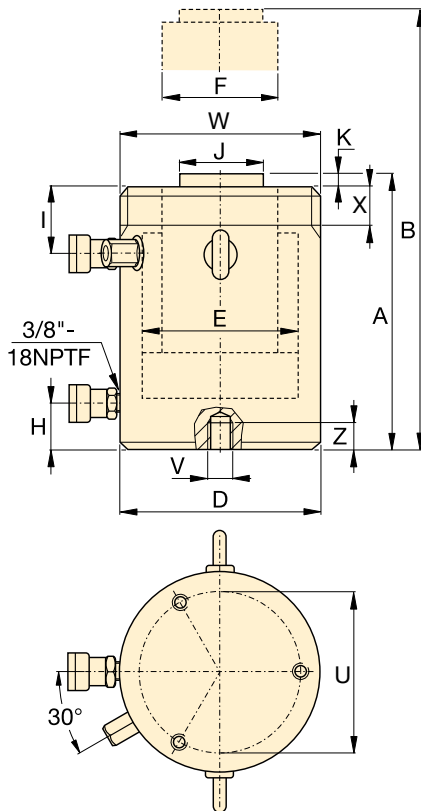

SELECTION CHART AND DETAILS OF 400 – 1000-TON HCR-MODELS

For 50 – 300-ton models, see pages 52-53.

For full product features see pages 44-45.

Cylinder Capacity (ton)	Stroke (in)	Model Number	Maximum Cylinder Capacity at 10,150 psi (ton)	Cylinder Effective Area (in ²)	Oil Capacity (in ³)		Collapsed Height A (in)
					Advance	Retract	
400	1.97	HCR4002	450	88.75	174.70	58.71	12.64
	3.94	HCR4004			349.39	117.42	14.61
	5.91	HCR4006			524.09	176.14	16.57
	7.87	HCR4008			698.79	234.85	18.54
	9.84	HCR40010			873.49	293.56	20.51
	11.81	HCR40012			1048.18	352.27	22.48
500	1.97	HCR5002	575	113.25	222.92	73.15	13.54
	3.94	HCR5004			445.85	146.30	15.51
	5.91	HCR5006			668.77	219.45	17.48
	7.87	HCR5008			891.70	292.60	19.45
	9.84	HCR50010			1114.62	365.75	21.42
	11.81	HCR50012			1337.55	438.90	23.39
600	1.97	HCR6002	673	132.57	260.97	86.27	13.86
	3.94	HCR6004			521.94	172.54	15.83
	5.91	HCR6006			782.90	258.81	17.80
	7.87	HCR6008			1043.87	345.08	19.76
	9.84	HCR60010			1304.84	431.35	21.73
	11.81	HCR60012			1565.81	517.62	23.70
800	1.97	HCR8002	916	180.44	355.21	109.81	15.91
	3.94	HCR8004			710.41	219.63	17.87
	5.91	HCR8006			1065.62	329.44	19.84
	7.87	HCR8008			1420.82	439.26	21.81
	9.84	HCR80010			1776.03	549.07	23.78
	11.81	HCR80012			2131.24	658.89	25.75
1000	1.97	HCR10002	1196	235.68	463.94	186.92	17.40
	3.94	HCR10004			927.88	373.84	19.37
	5.91	HCR10006			1391.83	560.76	21.34
	7.87	HCR10008			1855.77	747.68	23.31
	9.84	HCR100010			2319.71	934.59	25.28
	11.81	HCR100012			2783.65	1121.51	27.24

Collar Thread (in)		
Model / Capacity (ton)	Thread Size W	Thread Length X
HCR400	M350 x 3	3.27
HCR500	M400 x 4	3.54
HCR600	M430 x 4	3.94
HCR800	M505 x 5	4.80
HCR1000	M570 x 5	5.39

Collar thread is optional on 300 ton models and higher. For collar thread on cylinder add suffix "E002" to model number. Example: **HCR4006E002**. The collar thread length is designed for the full rated cylinder capacity.

Base Mounting Holes (in)					
Model / Capacity (ton)	Bolt Circle U	Thread Size V	Min. Thread Depth Z	Number of Holes	Angle from Coupler
HCR400	11.81	M16 x 2	0.98	3	60°
HCR500	13.39	M24 x 3	1.42	3	60°
HCR600	14.57	M24 x 3	1.42	3	60°
HCR800	17.32	M24 x 3	1.42	3	60°
HCR1000	19.69	M24 x 3	1.42	3	60°

Double-Acting, High-Tonnage Cylinders

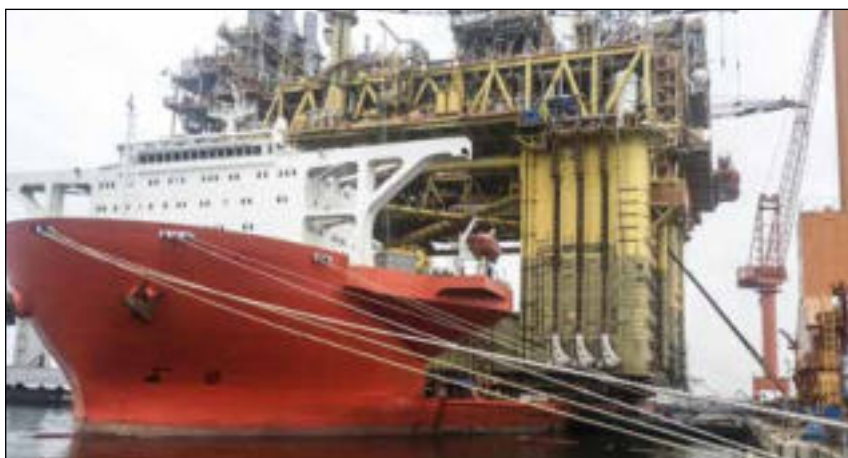

HCR Series



Capacity:
400 - 1000 ton

Stroke:
1.97 - 11.81 inches

Maximum Operating Pressure:
10,150 psi

▲ The superlifting and launch of a 43,000-ton floating oil production system in Malaysia for the Gumusut-Kakap offshore field has set high benchmarks for safety through its use of sophisticated EVO-Series synchronous hydraulics to lift, balance, weigh and smoothly launch massive resource structures.

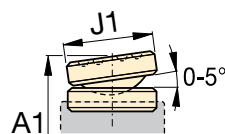

CATS-Series Tilt Saddle

Extended Height	Outside Diameter	Cylinder Bore Diameter	Plunger Diameter	Base to Advance Port	Top to Retract Port	Standard Saddle Diameter	Saddle Protrusion from Plunger	Retract Oil Volume	Weight	Model Number	Optional Tilt Saddle		
											Saddle Diameter J1	Collap. Height* A1	Saddle Model Number
B (in)	D (in)	E (in)	F (in)	H (in)	I (in)	J (in)	K (in)	(in ³)	(lbs)		(in)	(in)	
14.61	13.78	10.63	8.66	2.91	4.37	6.26	0.16	58.71	501	HCR4002	8.27	14.53	CATS400
18.54								117.42	570	HCR4004		16.50	
22.48								176.14	638	HCR4006		18.46	
26.42								234.85	707	HCR4008		20.43	
30.35								293.56	775	HCR40010		22.40	
34.29								352.27	843	HCR40012		24.37	
15.51	15.75	12.01	9.84	3.11	4.76	7.05	0.16	73.15	706	HCR5002	9.06	15.43	CATS500
19.45								146.30	797	HCR5004		17.40	
23.39								219.45	887	HCR5006		19.37	
27.32								292.60	977	HCR5008		21.34	
31.26								365.75	1,067	HCR50010		23.31	
35.20								438.90	1,158	HCR50012		25.28	
15.83	16.93	12.99	10.63	3.35	4.76	7.64	0.16	86.27	836	HCR6002	9.84	15.94	CATS600
19.76								172.54	940	HCR6004		17.91	
23.70								258.81	1,044	HCR6006		19.88	
27.64								345.08	1,148	HCR6008		21.85	
31.57								431.35	1,252	HCR60010		23.82	
35.51								517.62	1,356	HCR60012		25.79	
17.87	19.88	15.16	12.60	3.94	5.63	8.82	0.16	109.81	1,340	HCR8002	10.83	18.15	CATS800
21.81								219.63	1,485	HCR8004		20.12	
25.75								329.44	1,631	HCR8006		22.00	
29.69								439.26	1,777	HCR8008		24.00	
33.62								549.07	1,922	HCR80010		26.00	
37.56								658.89	2,068	HCR80012		28.00	
19.37	22.44	17.32	13.39	4.49	6.02	9.80	0.16	186.92	1,858	HCR10002	11.81	20.43	CATS1000
23.31								373.84	2,031	HCR10004		22.40	
27.24								560.76	2,205	HCR10006		24.37	
31.18								747.68	2,379	HCR10008		26.34	
35.12								934.59	2,552	HCR100010		28.31	
39.06								1121.51	2,726	HCR100012		30.28	

* A1 = Collapsed height including CATS-Series tilt saddle.

HCL-Series, Single-Acting, Load-Return Cylinders

- Lock nut provides positive and safe mechanical load holding
- Low-friction locking rings spin easy, save time and effort
- Designed to withstand 10% side-load up to 90% of maximum stroke
- Hardened surface resists side-loading and cyclic wear
- Overflow port as stroke limiter to prevent plunger blow-out
- Weather protected, inside and out
- Replaceable bearings enclose the plunger for support throughout the stroke
- Certified lifting eyes and base mounting holes

SELECTION CHART 50 – 300-TON HCL-MODELS

For 400 – 1000-ton models, see pages 58-59.

For full product features see pages 44-45.

Cylinder Capacity (ton)	Stroke (in)	Model Number	Maximum Cylinder Capacity at 10,150 psi (ton)	Cylinder Effective Area (in ²)	Oil Capacity (in ³)	Collapsed Height A (in)
50	1.97	HCL502	62	12.17	23.96	6.46
	3.94	HCL504			47.93	8.43
	5.91	HCL506			71.89	10.39
	7.87	HCL508			95.86	12.36
	9.84	HCL5010			119.82	14.33
	11.81	HCL5012			143.78	16.30
100	1.97	HCL1002	113	22.19	43.67	7.36
	3.94	HCL1004			87.35	9.33
	5.91	HCL1006			131.02	11.30
	7.87	HCL1008			174.70	13.27
	9.84	HCL10010			218.37	15.24
	11.81	HCL10012			262.05	17.20
150	1.97	HCL1502	168	33.14	65.24	8.23
	3.94	HCL1504			130.48	10.20
	5.91	HCL1506			195.73	12.17
	7.87	HCL1508			260.97	14.13
	9.84	HCL15010			326.21	16.10
	11.81	HCL15012			391.45	18.07
200	1.97	HCL2002	223	43.95	86.51	9.37
	3.94	HCL2004			173.02	11.34
	5.91	HCL2006			259.53	13.31
	7.87	HCL2008			346.04	15.28
	9.84	HCL20010			432.55	17.24
	11.81	HCL20012			519.06	19.21
250	1.97	HCL2502	286	56.27	110.77	9.80
	3.94	HCL2504			221.55	11.77
	5.91	HCL2506			332.32	13.74
	7.87	HCL2508			443.09	15.71
	9.84	HCL25010			553.87	17.68
	11.81	HCL25012			664.64	19.65
300	1.97	HCL3002	341	67.23	132.34	10.94
	3.94	HCL3004			264.68	12.91
	5.91	HCL3006			397.02	14.88
	7.87	HCL3008			529.36	16.85
	9.84	HCL30010			661.71	18.82
	11.81	HCL30012			794.05	20.79

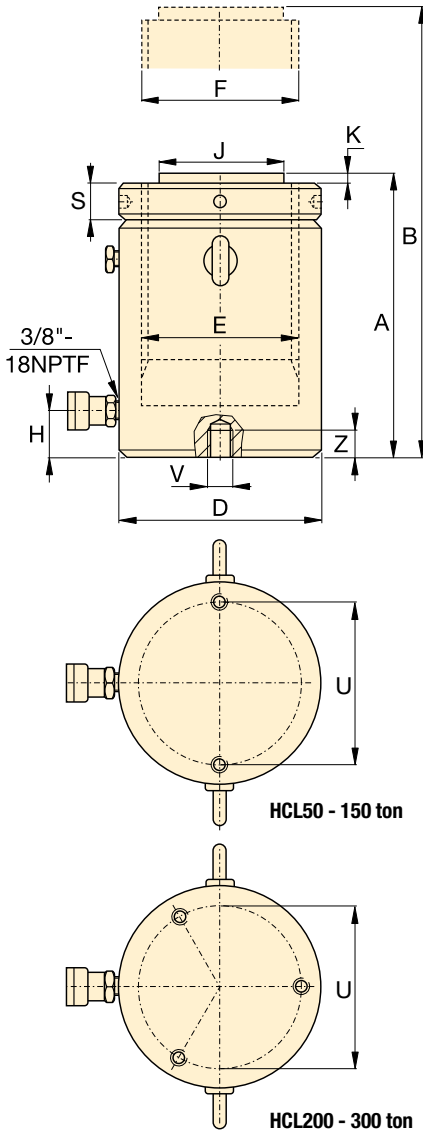

Base Mounting Holes (in)					
Model / Capacity (ton)	Bolt Circle U	Thread Size V	Minimum Thread Depth Z	Number of Holes	Angle from Coupler
HCL50	4.13	M8 x 1.25	0.39	2	90°
HCL100	5.91	M12 x 1.75	0.67	2	90°
HCL150	7.28	M12 x 1.75	0.87	2	90°
HCL200	8.46	M12 x 1.75	0.87	3	60°
HCL250	9.65	M12 x 1.75	0.87	3	60°
HCL300	10.24	M16 x 2	0.98	3	60°

Single-Acting, High-Tonnage Lock Nut Cylinders

Capacity:
50 - 300 ton

Stroke:
1.97 - 11.81 inches

Maximum Operating Pressure:
10,150 psi

HCL Series

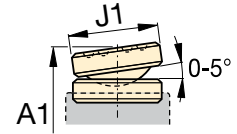

CATS-Series Tilt Saddle

	Extended Height	Outside Diameter	Cylinder Bore Diameter	Plunger Diameter	Base to Advance Port	Standard Saddle Diameter	Saddle Protrusion from Plunger K (in)	Lock Nut Height	Weight	Model Number	Optional Tilt Saddle			
											Saddle Diameter J1 (in)	Collap. Height* A1 (in)	Saddle Model Number	
	8.43	5.12	3.94	Tr 100 x 4	0.94	2.80	0.08	0.98	37	HCL502	2.80	7.05	CATS100	
	12.36								48	HCL504				10.98
	16.30								60	HCL506				
	20.24								71	HCL508				
	24.17								83	HCL5010				
	28.11								94	HCL5012				
	9.33	6.89	5.31	Tr 135 x 6	1.30	2.80	0.08	1.30	77	HCL1002	2.80	7.95	CATS100	
	13.27								98	HCL1004				11.89
	17.20								118	HCL1006				
	21.14								139	HCL1008				
	25.08								160	HCL10010				
	29.02								181	HCL10012				
	10.20	8.46	6.50	Tr 165 x 6	1.61	5.12	0.08	1.57	130	HCL1502	4.96	8.86	CATS201	
	14.13								161	HCL1504				12.80
	18.07								192	HCL1506				
	22.01								224	HCL1508				
	25.94								255	HCL15010				
	29.88								287	HCL15012				
	11.34	9.84	7.48	Tr 190 x 6	1.85	5.12	0.08	1.77	188	HCL2002	4.96	10.00	CATS201	
	15.28								231	HCL2004				13.94
	19.21								273	HCL2006				
	23.15								316	HCL2008				
	27.09								358	HCL20010				
	31.02								401	HCL20012				
	11.77	11.02	8.46	Tr 215 x 6	2.09	5.51	0.08	2.05	262	HCL2502	6.89	11.34	CATS300	
	15.71								316	HCL2504				15.28
	19.65								369	HCL2506				
	23.58								422	HCL2508				
	27.52								476	HCL25010				
	31.46								529	HCL25012				
	12.91	12.01	9.25	Tr 235 x 6	2.28	5.51	0.08	2.20	348	HCL3002	6.89	12.48	CATS300	
	16.85								411	HCL3004				16.42
	20.79								474	HCL3006				
	24.72								537	HCL3008				
	28.66								601	HCL30010				
	32.60								664	HCL30012				

* A1 = Collapsed height including CATS-Series tilt saddle.

HCL-Series, Single-Acting, Load Return Cylinders

- Lock nut provides positive and safe mechanical load holding
- Low-friction locking rings spin easy, save time and effort
- Designed to withstand 10% side-load up to 90% of maximum stroke
- Hardened surface resists side-loading and cyclic wear
- Overflow port as stroke limiter to prevent plunger blow-out
- Weather protected, inside and out
- Replaceable bearings enclose the plunger for support throughout the stroke
- Certified lifting eyes and base mounting holes

SELECTION CHART 400 – 1000-TON HCL-MODELS

For 50 – 300-ton models, see pages 56-57.

For full product features see pages 44-45.

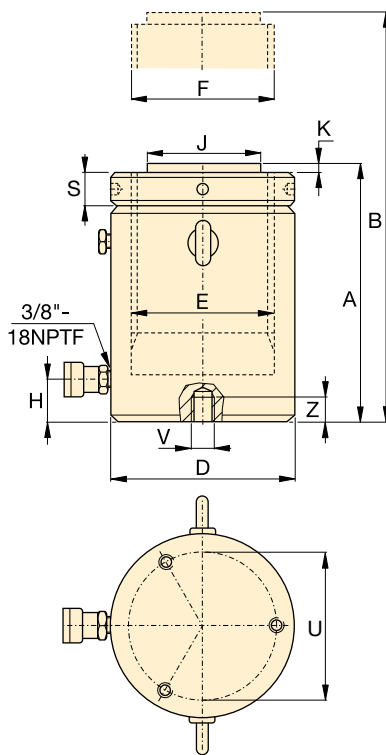

Cylinder Capacity (ton)	Stroke (in)	Model Number	Maximum Cylinder Capacity at 10,150 psi (ton)	Cylinder Effective Area (in ²)	Oil Capacity (in ³)	Collapsed Height A (in)
400	1.97	HCL4002	450	88.75	174.70	12.48
	3.94	HCL4004			349.39	14.45
	5.91	HCL4006			524.09	16.42
	7.87	HCL4008			698.79	18.39
	9.84	HCL40010			873.49	20.35
	11.81	HCL40012			1,048.18	22.32
500	1.97	HCL5002	575	113.25	222.92	14.06
	3.94	HCL5004			445.85	16.02
	5.91	HCL5006			668.77	17.99
	7.87	HCL5008			891.70	19.96
	9.84	HCL50010			1,114.62	21.93
	11.81	HCL50012			1,337.55	23.90
600	1.97	HCL6002	673	132.57	260.97	14.96
	3.94	HCL6004			521.94	16.93
	5.91	HCL6006			782.90	18.90
	7.87	HCL6008			1,043.87	20.87
	9.84	HCL60010			1,304.84	22.83
	11.81	HCL60012			1,565.81	24.80
800	1.97	HCL8002	916	180.44	355.21	16.93
	3.94	HCL8004			710.41	18.90
	5.91	HCL8006			1,065.62	20.87
	7.87	HCL8008			1,420.82	22.83
	9.84	HCL80010			1,776.03	24.80
	11.81	HCL80012			2,131.24	26.77
1000	1.97	HCL10002	1196	235.68	463.94	19.06
	3.94	HCL10004			927.88	21.02
	5.91	HCL10006			1,391.83	22.99
	7.87	HCL10008			1,855.77	24.96
	9.84	HCL100010			2,319.71	26.93
	11.81	HCL100012			2,783.65	28.90

Base Mounting Holes (in)					
Model / Capacity (ton)	Bolt Circle U	Thread Size V	Minimum Thread Depth Z	Number of Holes	Angle from Coupler
HCL400	11.81	M16 x 2	0.95	3	60°
HCL500	13.39	M24 x 3	1.42	3	60°
HCL600	14.57	M24 x 3	1.42	3	60°
HCL800	17.32	M24 x 3	1.42	3	60°
HCL1000	19.69	M24 x 3	1.42	3	60°

Single-Acting, High Tonnage, Lock Nut Cylinders



HCL Series



Capacity:

400 - 1000 ton

Stroke:

1.97 - 11.81 inches

Maximum Operating Pressure:

10,150 psi

▲ Heavy lifting and foundation levelling. The lock nut provides mechanical load holding over a long period of time.

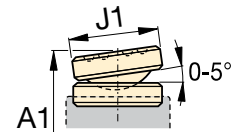

CATS-Series Tilt Saddle

Extended Height	Outside Diameter	Cylinder Bore Diameter	Plunger Diameter	Base to Advance Port	Standard Saddle Diameter	Saddle Protrusion from Plunger	Lock Nut Height	Weight	Model Number	Optional Tilt Saddle			
										Saddle Diameter J1	Collap. Height* A1	Saddle Model Number	
B (in)	D (in)	E (in)	F (mm)	H (in)	J (in)	K (in)	S (in)	(lbs)					
14.45	13.78	10.63	Tr 270 x 6	2.64	6.26	0.20	2.56	520	HCL4002	8.27	14.37	CATS400	
18.39								603	HCL4004				16.34
22.32								686	HCL4006				18.31
26.26								770	HCL4008				20.28
30.20								853	HCL40010				22.24
34.13								936	HCL40012				24.21
16.02								15.75	12.01				Tr 305 x 6
19.96	860	HCL5004	17.91										
23.90	968	HCL5006	19.88										
27.83	1,077	HCL5008	21.85										
31.77	1,186	HCL50010	23.82										
35.71	1,294	HCL50012	25.79										
16.93	16.93	12.99	Tr 330 x 6	3.19	7.64	0.20	3.15			942	HCL6002	9.84	
20.87								1,067	HCL6004	19.02			
24.80								1,193	HCL6006	20.98			
28.74								1,319	HCL6008	22.95			
32.68								1,444	HCL60010	24.92			
36.61								1,570	HCL60012	26.89			
18.90								19.88	15.16	Tr 385 x 6	3.74		8.82
22.83	1,646	HCL8004	21.14										
26.77	1,819	HCL8006	23.11										
30.71	1,992	HCL8008	25.08										
34.65	2,166	HCL80010	27.05										
38.58	2,339	HCL80012	29.02										
21.02	22.44	17.32	Tr 440 x 6	4.33	9.81	0.20	4.13					2,115	
24.96								2,335	HCL10004	24.06			
28.90								2,556	HCL10006	26.02			
32.83								2,777	HCL10008	27.99			
36.77								2,998	HCL100010	29.96			
40.71								3,219	HCL100012	31.93			

* A1 = Collapsed height including CATS-Series tilt saddle.

▼ Shown: HCRL2006, HCRL506



- Hydraulically controlled fast retraction
- Lock nut provides mechanical load holding for a safe work environment
- Designed to withstand up to 10% side-load of maximum capacity
- Integrated tilt saddle allows up to 5 degrees of misalignment
- Hardened surface resists side-loading and cyclic wear
- Weather protected, inside and out
- Replaceable bearings enclose the plunger externally and internally for support
- Certified lifting eyes, base mounting holes and collar thread as standard
- Stop-ring to prevent plunger blow-out
- Low friction lock nut, spin easy, save time and effort

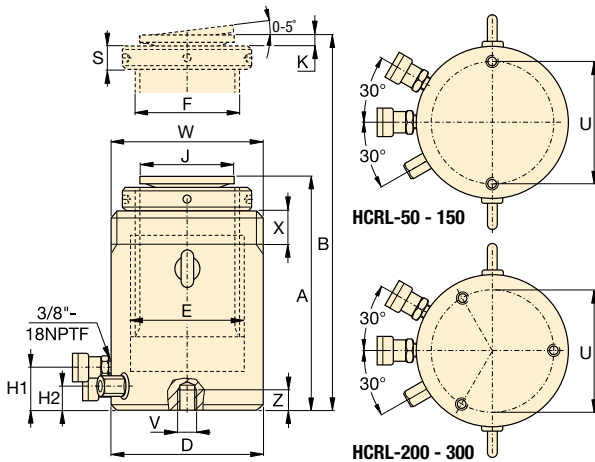

Collar Thread		
Model / Capacity (ton)	Thread Size W (mm)	Thread Length X (in)
HCRL50	M130 x 2	1.65
HCRL100	M185 x 2	2.24
HCRL150	M222 x 3	2.76
HCRL200	M260 x 3	3.09
HCRL250	M290 x 3	3.33
HCRL300	M315 x 3	3.68

The collar thread length is designed for the full rated cylinder capacity.

Base Mounting Holes			
Model / Capacity (ton)	Bolt Circle U (in)	Thread Size V (mm)	Min. Thread Depth Z (in)
HCRL50	4.13	M12 x 1.75	0.87
HCRL100	5.90	M12 x 1.75	0.87
HCRL150	7.28	M12 x 1.75	0.87
HCRL200	8.46	M12 x 1.75	0.87
HCRL250	9.65	M12 x 1.75	0.87
HCRL300	10.24	M16 x 2.00	0.98

Cylinder Capacity* (ton)	Stroke* (in)	Model Number	Maximum Cylinder Capacity at 10,150 psi (ton)	Cylinder Effective Area (in ²)	Oil Capacity (in ³)	
					Advance	Retract
50	5.91	HCRL506	54	10.60	62.55	5.24
	7.87	HCRL508			83.42	6.99
	9.84	HCRL5010			104.29	8.73
	11.81	HCRL5012			125.16	10.48
100	5.91	HCRL1006	111	21.91	129.41	14.38
	7.87	HCRL1008			172.54	19.17
	9.84	HCRL10010			215.68	23.96
	11.81	HCRL10012			258.81	28.76
150	5.91	HCRL1506	169	33.23	196.26	14.38
	7.87	HCRL1508			261.69	19.17
	9.84	HCRL15010			327.11	23.96
	11.81	HCRL15012			392.50	28.76
200	5.91	HCRL2006	225	44.31	261.62	32.35
	7.87	HCRL2008			348.87	43.14
	9.84	HCRL20010			436.06	53.92
	11.81	HCRL20012			523.31	64.70
250	5.91	HCRL2506	277	54.54	322.08	32.35
	7.87	HCRL2508			429.35	43.14
	9.84	HCRL25010			536.67	53.92
	11.81	HCRL25012			644.15	64.70
300	5.91	HCRL3006	334	65.74	388.23	32.35
	7.87	HCRL3008			517.60	43.14
	9.84	HCRL30010			647.03	53.92
	11.81	HCRL30012			776.41	64.70

* Up to 2000-ton and additional stroke lengths available on request.

Double Acting, High Tonnage, Lock Nut Cylinders



Higher Capacities, Longer Strokes

The HCRL-Series Cylinders are available up to 2000-ton and additional stroke lengths available on request. Contact Enerpac for more information.

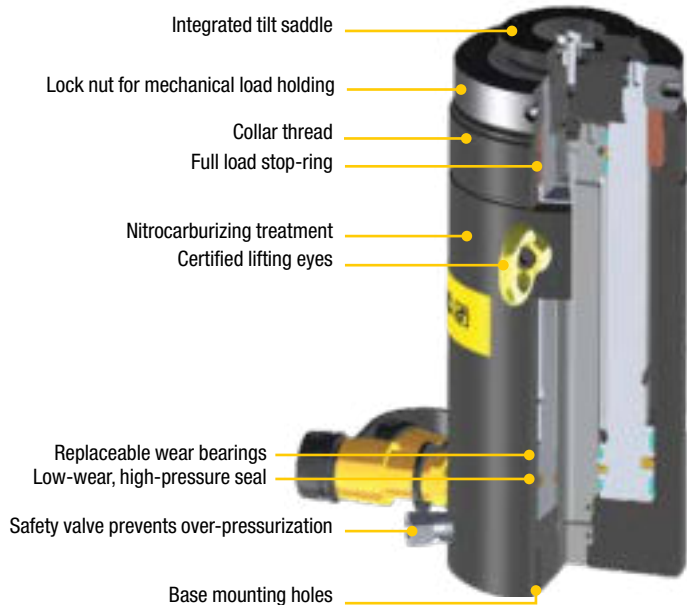

HCRL Series



Capacity:

54 - 334 ton

Stroke:

5.91 - 11.81 inches

Maximum Operating Pressure:

10,150 psi



EVO-Series, Synchronous Lifting Systems

The EVO-system is the safest system for multi-point lifting, provided synchronized control over lifting stroke with a wide variety of features and functions.

Collapsed Height	Extended Height	Outside Diameter	Cylinder Bore Diameter	Plunger Diameter	Base to Advance Port	Base to Retract Port	Saddle Diameter	Saddle Protrusion from Plunger	Lock Nut Height	Retract Oil Volume	Weight	Model Number
A (in)	B (in)	D (in)	E (in)	F (mm)	H1 (in)	H2 (in)	J (in)	K (in)	S (in)	(in ³)	(lbs)	
12.20	18.11	5.12	3.93	Tr90 x 4	1.61	1.04	3.02	0.59	1.02	1.75	65	HCRL506
14.84	22.71									3.49	79	HCRL508
16.81	26.65									5.24	88	HCRL5010
18.77	30.59									6.99	98	HCRL5012
13.62	19.52	7.28	5.51	Tr120 x 6	1.97	1.41	3.02	0.59	1.42	8.73	141	HCRL1006
16.57	14.44									10.48	170	HCRL1008
18.54	28.38									4.79	188	HCRL10010
20.51	32.32									9.59	207	HCRL10012
14.13	20.03	8.74	6.69	Tr150 x 6	1.81	1.24	4.96	0.51	1.77	14.38	213	HCRL1506
17.09	24.96									19.17	256	HCRL1508
19.06	28.90									23.96	284	HCRL15010
21.02	32.83									28.76	312	HCRL15012
15.70	21.61	10.24	7.87	Tr170 x 6	2.80	1.92	4.96	0.51	1.97	4.79	318	HCRL2006
18.46	26.34									9.59	370	HCRL2008
20.43	30.28									14.38	406	HCRL20010
22.40	34.21									19.17	440	HCRL20012
16.38	22.28	11.42	8.66	Tr190 x 6	2.80	1.92	6.30	0.59	2.17	23.96	419	HCRL2506
19.33	27.20									28.76	492	HCRL2508
21.30	31.14									10.78	538	HCRL25010
23.27	35.08									21.57	584	HCRL25012
16.57	22.48	12.40	9.45	Tr210 x 6	2.80	1.92	6.30	0.59	2.17	32.35	505	HCRL3006
19.53	27.40									43.14	592	HCRL3008
21.50	31.34									53.92	647	HCRL30010
23.46	35.28									64.70	702	HCRL30012

▼ Shown cylinder-pump set: SCR1010H



The Quickest and Easiest Way to Start Working Right Away



Speed Chart

See the Enerpac Cylinder Speed Chart in our "Yellow Pages" section.

Page: 409



LW16 Lifting Wedge

Hydraulic cylinders, jacks and lifting wedges can also be used to assist in positioning and aligning.

The LW16 only requires an access gap of 0.39 inch. See our "Specialty Tools" section on www.enerpac.com.

Page: 212

- Optimum match of individual components
- All sets are ready to use and include single-acting cylinder, two-speed pump, 6-foot safety hose, calibrated gauge with gauge adaptor

1 Cylinder Selection (See Cylinder Section of this catalog for full product descriptions)		Nominal Set Capacity (ton)	Cylinder Model No.	Stroke (in)	Collapsed Height (in)
<p>RC-Series, Single-Acting, General Purpose Cylinders For maximum versatility.</p>	6	5	RC55	5.00	8.50
		10	RC102	2.13	4.78
			RC106	6.13	9.75
			RC1010	10.13	13.75
		15	RC154	4.00	7.88
			RC156	6.00	10.69
		25	RC252	2.00	6.50
			RC254	4.00	8.50
			RC256	6.25	10.75
			RC2514	14.25	18.75
<p>RCS-Series, Single-Acting, Low-Height Cylinders Ideal where space is restricted.</p>	26	10	RCS101	1.50	3.47
		20	RCS201	1.75	3.88
		30	RCS302	2.44	4.63
		50	RCS502	2.38	4.81
		100	RCS1002	2.25	5.56
<p>RCH-Series, Single-Acting, Hollow Cylinders For pushing and pulling applications.</p>	34	12	RCH121	1.63	4.75
		20	RCH202	2.00	6.31
		30	RCH302	2.50	7.03
		60	RCH603	3.00	9.75
		100	RCH1003	3.00	10.00

Single-Acting, Cylinder Pump Sets

SELECTION EXAMPLE

Selected cylinder:

- RC106, Single-acting cylinder with 6.13" stroke

Selected pump:

- P392, Lightweight hand pump

Set model number:

- SCR106H

Included:

- HC7206 hose
- GF10P gauge
- GA2 adaptor



GA45GC Gauge Adaptor³⁾

Protect yourself from system overloading by simply ordering one part number for a pre-assembled gauge, adaptor block and coupler.

Page: 162

SC Series



Capacity:

5 - 100 tons

Stroke:

1.50 - 14.25 inches

Maximum Operating Pressure:

10,000 psi



Hydraulic Tool Box

Tool box with hand pump, gauge adaptor assembly, hose and RC-, RCS-, RSM-Series cylinder.

Page: 65

SET SELECTION:

- 1 Select the cylinder
- 2 Select the pump
- 3 Find the set model number in the gray field of the matrix

2

Pump selection (See Pump Section of this catalog for full product descriptions)

Accessories Included

Hand Pump P142	Hand Pump P392	Hand Pump P80	Foot Pump P392FP	XA-Series Air Pump XA11	XC-Series Cordless Pump ²⁾ XC1202MB	Hose Model No.	Gauge Model No.	Gauge Adaptor Model No.
SCR55H	-	-	-	-	-	HC7206	GP10S	GA4
-	SCR102H	-	SCR102FP	SCR102XA	SCR102XCB	HC7206	GF10P	GA2
-	SCR106H	-	SCR106FP	SCR106XA	SCR106XCB	HC7206	GF10P	GA2
-	SCR1010H	-	SCR1010FP	SCR1010XA	SCR1010XCB	HC7206	GF10P	GA2
-	SCR154H	-	SCR154FP	SCR154XA	SCR154XCB	HC7206	GP10S	GA2
-	SCR156H	-	SCR156FP	SCR156XA	SCR156XCB	HC7206	GP10S	GA2
-	SCR252H	-	SCR252FP	SCR252XA	SCR252XCB	HC7206	GF20P	GA2
-	SCR254H	-	SCR254FP	SCR254XA	SCR254XCB	HC7206	GF20P	GA2
-	SCR256H	-	-	SCR256XA	SCR256XCB	HC7206	GF20P	GA2
-	-	SCR2514H	-	SCR2514XA ¹⁾	-	HC7206	GF20P	GA2
-	-	SCR506H	-	SCR506XA ¹⁾	-	HC7206	GF50P	GA2
-	SCL101H	-	SCL101FP	SCL101XA	-	HC7206	GF10P	GA2
-	SCL201H	-	SCL201FP	SCL201XA	-	HC7206	GF230P	GA2
-	SCL302H	-	SCL302FP	SCL302XA	SCL302XCB	HC7206	GF230P	GA2
-	SCL502H	-	SCL502FP	SCL502XA	SCL502XCB	HC7206	GF510P	GA2
-	-	SCL1002H	-	-	SCL1002XCB	HC7206	GF510P	GA2
SCH121H	-	-	-	-	-	HB7206	GF120P	GA4
-	SCH202H	-	SCH202FP	SCH202XA	SCH202XCB	HC7206	GF813P	GA3
-	SCH302H	-	SCH302FP	SCH302XA	SCH302XCB	HC7206	GF813P	GA3
-	-	SCH603H	-	SCH603XA ¹⁾	SCH603XCB	HC7206	GF813P	GA3
-	-	SCH1003H	-	-	-	HC7206	GP10S	GA2

¹⁾ With XA12 air pump

²⁾ XC Cordless Pump includes 115 V charger, for 230 V charger replace the "B" in the model number with an "E".

³⁾ XC Pump Sets include only the HC7206 Hose and GA45GC Gauge Adaptor accessories

▼ Shown from left to right: P142ALSS, P392ALSS, V152NV, V66NV, RC256NV, RC106NV, RC53NV



RC, P, V Series

Cylinder Capacity:

5 - 25 tons

Stroke:

2 - 6 inches

Maximum Operating Pressure:

10,000 psi



Applications

Use Enerpac **Extreme Environment Products** in wet environments such as food processing, pulp and paper, mining, construction and applications in high temperature or in welding areas.

- Corrosion resistant, nickel-plated valves and cylinders
- Stainless steel pump inserts will not corrode
- Viton® Seals provide heat and chemical resistance
- Anodized aluminum pump reservoirs and plastic encapsulated pump bodies resist wet environments
- Two-speed operation reduces pump handle strokes 78% compared to single-speed pumps
- Pump handles lock for easy carrying



Multifluid Hand Pumps

MP-Series corrosion resistant hand pumps for low pressure filling and high pressure testing applications, suitable for a wide range of fluids.

Page: 93

▼ CYLINDER CHART



Cylinder Capacity	Stroke	Model Number *	Oil Capacity	Pressure Rating	Collapsed Height	Extended Height	Outside Diameter	Weight
(ton)	(in)		(in ³)	(psi)	(in)	(in)	(in)	(lbs)
5	3.0	RC53NV	2.98	10,000	6.50	9.50	1.50	3.3
10	2.0	RC102NV	4.75	10,000	4.78	6.91	2.25	5.1
10	6.0	RC106NV	13.70	10,000	9.75	15.88	2.25	9.8
25	6.0	RC256NV	32.23	10,000	10.75	17.00	3.38	22.0

▼ HAND PUMP CHART



Pump Type	Oil Capacity	Model Number *	Pressure Rating	Oil Displacement per Stroke	Port Dimension	Piston Stroke	Weight
	(in ³)		(psi)	(in ³)	(in)	(in)	(lbs)
Two Speed	20	P142ALSS	200/10,000	0.221 / 0.055	1/4"-18 NPTF	0.50	4.5
	55	P392ALSS	200/10,000	0.687 / 0.151	3/8"-18 NPTF	1.00	9.0

▼ VALVE CHART



Valve Type	Model Number *	Pressure Function	Pressure Rating (psi)	Weight (lbs)
Manual Check Valve	V66NV	Check	10,000	4.5
Pressure Relief Valve	V152NV	+ 3% Repeatability	800-10,000	9.0

* For cylinder details see pages 7-9; for pump details see pages 84-85; for valve details see pages 168-169.

Portable Hydraulic Toolbox

▼ Shown: SCR106TB



- Includes a single-acting cylinder, two-speed lightweight hand pump (P392), gauge adaptor assembly (GA45GC), and 6 ft. rubber hose with couplers (HC9206C)
- Complete and ready-to-use hydraulic system
- Easy to carry sturdy toolbox
- All components ship inside the toolbox as one package

SCR, SCL, SRS Series

Capacity:
5 - 50 tons

Stroke:
0.44 - 10.13 inches

Maximum Operating Pressure:
10,000 psi







Gauge Adaptor Assembly

Toolbox sets include a 45 degree angled gauge adaptor assembly for improved operating ergonomics and safety.

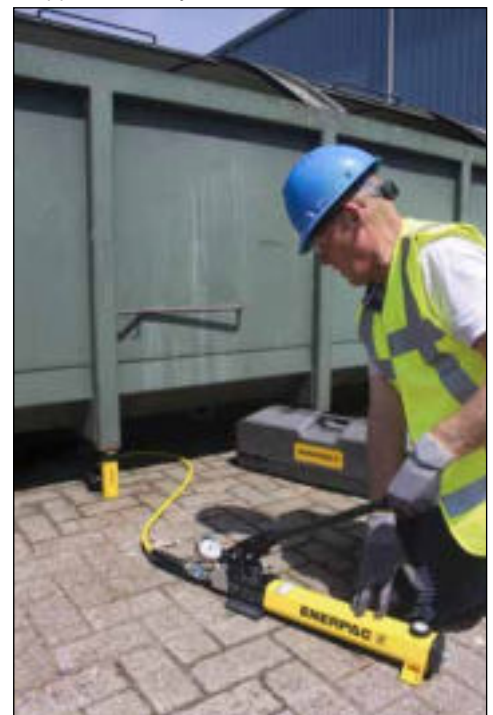
Page: 162

▼ The Hydraulic Toolbox is a versatile tool and applicable everywhere.



	Cylinder Model	Stroke (in)	Capacity (tons)	Weight (lbs)	Toolbox Set Model Number
 RC Series	General Purpose Cylinders				
	RC55	5.00	5	26	SCR55TB
	RC102	2.13	10	27	SCR102TB
	RC106	6.13	10	32	SCR106TB
	RC1010	10.13	10	36	SCR1010TB
	RC154	4.00	15	34	SCR154TB
	RC256	6.25	25	45	SCR256TB
 RCS Series	Low-Height Cylinders				
	RCS101	1.50	10	28	SCL101TB
	RCS201	1.75	20	33	SCL201TB
	RCS302	2.44	30	37	SCL302TB
	RCS502	2.38	50	44	SCL502TB
 RSM Series	Flat-Jac® Cylinders				
	RSM100	0.44	10	26	SRS100TB
	RSM200	0.44	20	28	SRS200TB
	RSM300	0.50	30	31	SRS300TB
	RSM500	0.63	50	37	SRS500TB

▼ Shown from left to right: JHA356, JHA156



JH, JHA Series

Capacity:
7 - 100 tons

Stroke:
3.00 - 6.13 inches

Maximum Operating Pressure:
10,000 psi

- All-directional operation on 7, 15 and 35-ton JHA-Series
- Internal relief valve to prevent overloading
- Machined flat front and bottom surfaces permit flush alignment in tight corners
- All models include pumping handle
- Chrome-plated plungers
- Automatic by-pass port to prevent over-extension (JH-Series)



Lifting Wedge and Machine Lifts

Ideal to lift the load the first few inches. The LW16 Lifting Wedge requires a very small access gap of only 0.39 inch.

Page: 212



Load Skates

For moving heavy loads easily and safely.

Page: 214

Style	Jack Capacity (ton)	Stroke (in)	Model Number	Jack Effective Area (in ²)	Collapsed Height (in)	Extended Height (in)	Bottom Plate Dimensions (W x L) (in)	Plunger Diameter (in)	Pump Speed	Weight (lbs)
Aluminum Jack	7	3.00	JHA73	1.49	5.25	8.25	2.88 x 6.25	1.19	Single	11
	15	6.06	JHA156	3.14	9.75	15.81	3.63 x 9.38	1.63	Single	29
	35	6.13	JHA356	7.07	10.13	16.25	4.63 x 10.00	2.13	Single	40
Steel Jack	30	6.13	JH306	5.94	10.00	16.13	3.75 x 9.56	2.75	Single	59
	50	6.09	JH506	9.62	10.25	16.34	5.00 x 10.19	3.50	2-Speed	90
	100	6.06	JH1006	20.63	11.31	17.37	7.13 x 12.94	5.12	2-Speed	184

Industrial Steel Bottle Jacks

▼ Shown: GBJ010A, GBJ030A, GBJ003A



GBJ Series

Capacity:

2 - 110 tons

Stroke:

2.44 - 18.11 inches



Screw Feature

Heat treated, adjustable extension screw with cleated saddle on selected GBJ models helps adjusting and prevents slipping.

- Lower handle effort reduces operator fatigue
- Fully serviceable
- High-strength beam and pump linkage for long life
- Pumping handle included on all models
- Safety relief valve to prevent overload
- Automatic by-pass port to prevent over-extension
- Wiper seal for extended life
- Thick base material with large area for increased strength and stability during lifting

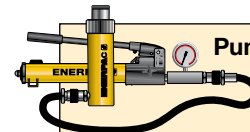

Pump and Cylinder Sets

As an alternative to Industrial Bottle Jacks where the operator is required to stand remote from the jacking point, see the range of pump and cylinder sets.

Page: 62

▼ Enerpac heavy-duty hydraulic bottle jack makes lifting loads easier.



Jack Cap.	Stroke	Model Number	Screw Extension	Min. Height	Max. Height	Plunger Dia.	Saddle Dia.	Base Dims. L x W	Wt
(ton)	(in)		(in)	(in)	(in)	(in)	(in)	(in)	(lbs)
2	18.11	GBJ002LA	-	22.44	40.55	1.14	-	5.00 x 5.00	22.1
3	4.13	GBJ003A	2.56	6.61	13.31	0.94	0.93	2.95 x 4.57	8.1
5	5.91	GBJ005A	2.95	8.35	17.20	1.14	1.12	2.95 x 4.92	9.9
8	5.91	GBJ008A	2.95	8.62	17.48	1.46	1.50	3.54 x 5.67	13.6
11	5.91	GBJ010A	2.95	8.62	17.48	1.46	1.50	3.54 x 5.67	14.1
11	2.44	GBJ010SA	1.18	5.16	8.78	1.46	1.50	3.54 x 5.67	11
17	5.91	GBJ015A	2.95	8.98	17.83	1.75	1.77	4.41 x 6.42	19.4
22	5.91	GBJ020A	2.95	9.21	18.07	2.00	2.40	4.72 x 6.77	23.3
22	4.13	GBJ020SA	2.17	7.48	13.78	2.00	2.40	4.72 x 6.77	20.9
33	5.91	GBJ030A	2.95	9.53	18.39	2.27	2.72	5.67 x 7.72	34.2
55	5.51	GBJ050A	-	10.24	15.75	3.15	3.15	6.50 x 8.43	59.4
110	5.91	GBJ100	-	11.81	17.72	4.33	3.70	11.65 x 13.11	191.8

All GBJ Jacks meet or exceed: ANSI, PALD, CE

▼ Shown: PRASA10027L and Accessory Locking U-Rings



Safe, Efficient, Mobile Load Lifting



Pendant Cord

Standard 12 ft. pendant cord for air driven units with pneumatic valves and 20 ft. pendant cord for electric driven units keeps operator away from the load.



POW'R LOCK – Self-Locking Mobile Lift System

A self-locking jack that performs automatic locking during lifting, lowering and holding. See the Enerpac PL-Series.

Page: 70

- 60, 100, 150 and 200-ton capacities with pneumatic or electric pumps for the toughest jobs
- 4-inch ground clearance for transport over rail and rough terrain
- Three-position handle provides easy tilt back and transport
- Complies with ASME/ANSI B30.1:2015 & CE specifications
- Easy-to-change external filter minimizes down time
- Rugged, fully enclosed 24-inch wide frame with no exposed fittings or hoses
- SUP-R-STACK™ Extension System allows lifting at all heights without blocking.



◀ Enerpac POW'R-RISER® used in mining operations to lift heavy equipment.

Capacity	Stroke	Electric Pump Model Number	Weight
(ton)	(in)	(115 VAC)	(lbs)
60	14	PREMB06014L	390
	27	PREMB06027L	600
100	16	PREMB10016L	510
	27	PREMB10027L	600
	16	-	-
150	27	-	-
	15.5	-	-
	26.5	-	-
	15.5	PREMB15016L	570
200	26.5	PREMB15027L	708
	15.3	-	-
	24.3	-	-

(PR-Series not available in Canada. Contact Enerpac.)

POW'R-RISER® Lifting Jack



SUP-R-STACK™ Extensions

Increase useful height from 5" to 18".

Model No.	Size (in)	Model No.	Size (in)
PRE5	5	PRE11	11
PRE7	7	PRE14	14
PRE9	9	PRE18	18
PRES6024	Extension set includes PRE5, PRE7, PRE11, PRE18		



Spacers

Fine tune your Extension stack height.

Model No.	Size (in)	Model No.	Size (in)
PRS1	1	PRS3	3
PRS2	2	-	-
PRS4	Set includes (2) PRS1, (1) PRS2 and (1) PRS3		

PR Series



Rated Lifting Capacity:

60 - 200 tons

Stroke:

14 - 27 inches

Maximum Operating Pressure:

10,000 psi

Cap. (ton)	Swivel Load Cap	Locking U-Rings					Set Model Number	Locking U-Ring Sets Include						
		1 in.	3 in.	4 1/4 in.	5 1/2 in.	10 in.		(quantity and model numbers)						
							2X	1X	2X	1X				
60	PRTS60	PRU11	PRU13	PRU14	-	PRU110	1) PRUS126	PRU11	PRU13	PRU14	-			
							2) PRUS137	PRU11	PRU13	PRU14	PRU10			
100	PRTS60	PRU11	PRU13	PRU14	-	PRU110	1) PRUS126	PRU11	PRU13	PRU14	-			
							2) PRUS137	PRU11	PRU13	PRU14	PRU110			
150	PRTS150	PRU151	PRU153	-	PRU155	PRU1510	3) PRUS1526	PRU151	PRU153	PRU155	-			
							2) PRUS1537	PRU151	PRU1510	PRU155	-			
200	PRTS200	PRU201	PRU203	-	PRU205	PRU2010	3) PRUS2026	PRU201	PRU203	PRU205	-			
							2) PRUS2037	PRU201	PRU2010	PRU205	-			

1) For 14 and 16" stroke models

2) For 27" stroke models

3) For 15.5" stroke models

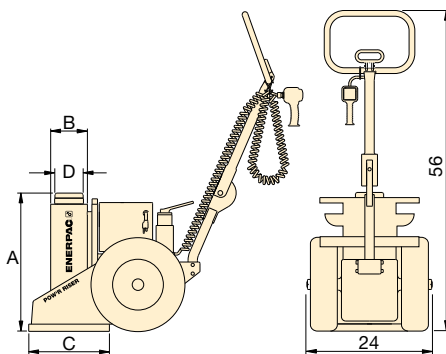

WARNING!

Extensions: Any two Extensions may be stacked for loads up to 60 tons. For loads over 60 tons or strokes over 14" only one Extension and one Spacer can be used.

Spacers: Never exceed 3" in total Spacer height.



Locking U-Rings

For safe mechanical cribbing of a lifted load, accessory Locking U-Rings can be placed around an extended piston and come in four lengths for each POW'R-Riser® capacity, and are available individually or in sets. Locking U-Rings are accommodated by storage racks integral to the POW'R-Riser®.

Air Pump	Weight (lbs)	A (in)	B (in)	C (in)	D (in)	Max. Additional Stack Height Using Optional Ext. System (in)	Valve Type
PRAMA06014L	390	24	6.4	14	4	32*	Manual
PRAMA06027L	600	37	6.4	14	4	11	
PRAMA10016L	510	26	7.0	18	4	21**	Pneumatic
PRAMA10027L	600	37	7.0	18	4	11	
PRASA10016L	510	26	7.0	18	4	21**	
PRASA10027L	600	37	7.0	18	4	11	
PRASA15016L	570	26	8.0	18	5	21**	Pneumatic
PRASA15027L	708	37	8.0	18	5	11	
-	-	26	8.0	18	5	21**	Manual
-	-	37	8.0	18	5	11	
PRASA20016L	640	26	9.5	20	6	21**	Pneumatic
PRASA20027L	825	37	9.5	20	6	11	

* Based on one 18" and one 11" Extension and one 3" Spacer.

** Based on one 18" Extension and one 3" Spacer.

For power source, the following characters should be inserted in the 5th space of the model number.

Ordering Example:

Model No. PREMI06014L is a 14" stroke, 60 ton model, with a manual valve and a 208-240 VAC, 1-ph electric motor.

- A Air Pump, 50 scfm, 80 psi
- B 115 VAC, 1-ph., 50-60 Hz, 20 A
- E 208-240 VAC, 1-ph., 50-60 Hz, Euro Plug, 10 A
- I 208-240 VAC, 1-ph., 50-60 Hz, USA Plug, 10 A
- G 1)208-240 VAC, 3-ph., 50-60 Hz
- W 1)380-415 VAC, 3-ph., 50-60 Hz
- J 1)440-480 VAC, 3-ph., 50-60 Hz
- R 1)575 VAC, 3-ph., 50-60 Hz

1) Not available for 60-ton capacity

▼ Shown: PL20025-ASA and PL20014-ASA



- Provides continuous locking protection during lift, lower and hold functions
- Patent-pending control technology synchronizes cylinder and lock nut for smooth and efficient lifting and lowering
- Unique double-acting cylinder offers a low collapsed height to accommodate more lifting applications
- Simple 2-button pendant allows operation of raise and lower functions from up to 20 feet away
- All exposed load-bearing steel cylinder components utilize a nitrocarburizing treatment to reduce wear and resist corrosion
- Ergonomic handle has six positions for comfortable handling and folds when not in use
- Meets ANSI /ASME B30.1-2015, AS/NZS-2538, AS/NZS-2693 certification criteria

Efficient Lifting with Continuous, Automatic Load Locking



Pow'R-LOCK™ Self-Locking Lift System

Only the **Pow'R-LOCK™** Lift System provides continuous positive locking of the load through all stages of lifting and lowering. No operator intervention is required to activate or deactivate the automatic locking system.

Two different stroke lengths are available. Both models are powered by an external compressed air system (user-supplied). A convenient two-button pendant controls operation of the Lift System's air motor and directional control valve.



Tilt Load Cap

All **Pow'R-LOCK™** Lift System models feature a Tilt Load Cap to reduce side-loading.



Enerpac declares that this product has been tested and conforms to applicable standards and is approved to carry the CE mark. An EU Declaration of Conformity is enclosed separately.



◀ *The PL-Series Pow'R-LOCK Portable Lift System.*

Pow'R-LOCK™ Portable Lift System



Accessories

Flat Load Cap – Non-tilt load cap has lower profile for tight lifting spaces.

Spacers – Minimize gap between load cap and lifting point to maximize hydraulic stroke of the jack.

Extensions – Stackable, with large alloy steel locating studs to resist effects of side-loading.

Extension Base Adapter – Extension Base Adapter design eliminates risk of improper stacking when using more than one extension.



PL Series

Rated Lifting Capacity:

200 tons

Stroke:

14 or 24.5 inches

Maximum Operating Pressure:

10,000 psi

▼ ACCESSORIES

	Model Number	Description	Height (in)	PL20014-ASA	PL20025-ASA
	PLC1	Flat Load Cap	1.3	x	x
	PLS1	Spacer	1.0	x	x
	PLS2	Spacer	2.0	x	x
	PLE5	Extension	5.0	x	x
	PLE7	Extension	7.0	x	x
	PLE9	Extension	9.0	x	x
	PLE11	Extension	11.0	x	–
	PLE14	Extension	14.0	x	–
	PLB12	Extension base adapter	12.0	x	–



WARNING!

PLE11 and **PLE14** Extensions and **PLB12** Extension Base Adapter are to be used with the "short" model **PL20014-ASA** only.

Use of these extensions on the "tall" model **PL20025-ASA** will result in an excessive maximum lifting height. Load could become unstable and drop, resulting in possible personal injury and/or property damage.

Model No.	Max. Additional Stack Height* (in)
PL20014-ASA	28.0
PL20025-ASA	9.0

* Using optional PLB and PLE-Series extensions and PLS-Series spacers. Load cap height is NOT included in the stack height.



Safety First

When lifting large, heavy vehicles certain precautions must be followed. Follow your published safety directions for lifting and cribbing your loads.

The **Pow'R-LOCK™** Lift System provides load/lock protection, but you must follow the safety directions for load cribbing operations.

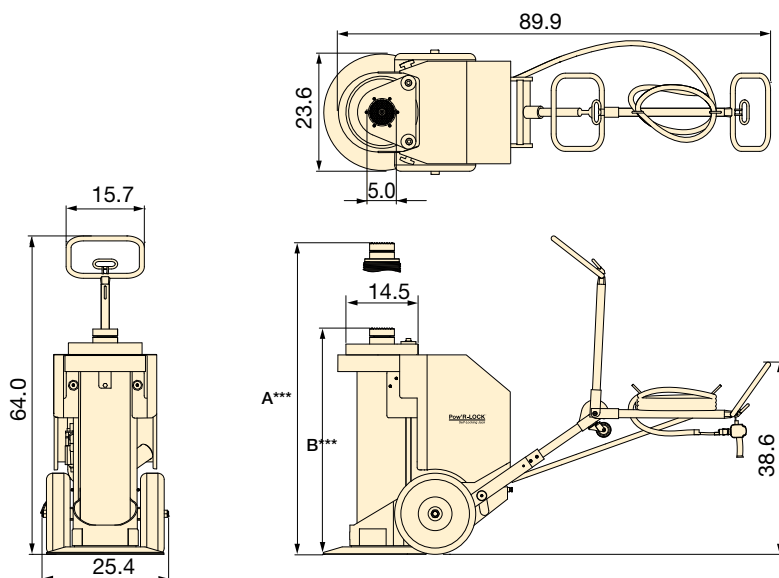

Capacity (ton)	Stroke (in)	Model Number	Cylinder Lifting Speed * in/min		Recommended Air Supply**		A *** (in)	B *** (in)	Wt. (lbs)
			Load	No Load	(CFM)	(psi)			
200	14.0	PL20014-ASA	2.0	2.4	130-150	55-100	48.0	34.0	1105
	24.5	PL20025-ASA	2.0	2.4					

* Depending on available airflow, regulator setting, pump speed and load weight.
 ** Minimum dynamic air pressure of 55-60 psi, 90-100 psi required to achieve 200-ton capacity.
 *** Height of items A and B is with swivel load cap installed. Subtract 2-inches if flat load cap is used.



Pow'R-RISER® Lifting Jack

When automatic load-locking is not required, the Enerpac **Pow'R-RISER®** jack provides a mobile lifting solution.

For more information go to:
www.enerpac.com

▼ Shown: BLS1006



- Climbing Jacks include integral tilt saddles with maximum tilt angles up to 5°
- Large base with anti-rotation rod for stability and safety
- Built-in safety valve prevents accidental over-pressurization
- Baked enamel finish for increased corrosion resistance
- CR400 couplers included on all cylinder models

A Simple Solution to Incremental Lifting



Lifting Height

Climbing Jacks overcome the usual limitation of lift height imposed by the jack's plunger stroke length. Large objects, such as oil tanks, can be lifted, held and lowered for maintenance without sending for a crane.



Split-Flow Pumps

SFP-Series Pumps with multiple outlets with equal oil flow. For lifting applications on multiple points Split-Flow

Pumps are a far better alternative than using independently operated pumps.

Page: 132



EVO-Series, Synchronous Lifting Systems

The EVO-system is the safest system for multi-point lifting, provided synchronized control over lifting stroke with a wide variety of features and functions.

Page: 136



Jack-Up System

For incremental lifting with higher lifting capacities and up to 66 feet lifting height, see our JS-Series Jack-Up Systems.

Page: 366

▼ Synchronous Stage Lifting: 48 double-acting jacks (25 and 50 ton) are networked into a 16 point synchronous system to lift this 164-foot, 1100-ton building up to a height of 8-feet to construct a new floor level.



Cylinder Capacity	Stroke	Model Number	Max. Cylinder Capacity (tons)	
			Push	Pull
(tons)	(in)			
55	5.91	BLS506	55	12
105	6.34	BLS1006	105	48
154	5.94	BLS1506	154	74
220	5.94	BLS2006	220	113

Double-Acting Climbing Jacks



◀ Typical stage-lift application using a custom built Enerpac system to lift the 360 ton Akkerwinde wooden bridge in the Netherlands.

BLS Series



Capacity per Lifting Point:

55 - 220 tons

Stroke per Stage:

5.91 - 6.34 inches

Maximum Operating Pressure:

10,000 psi

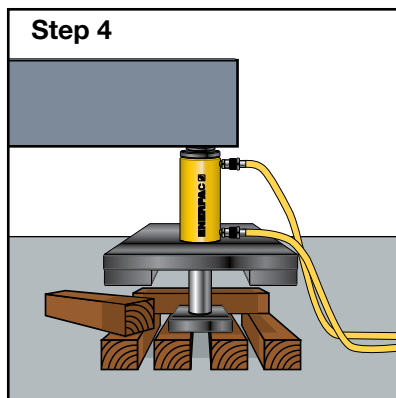
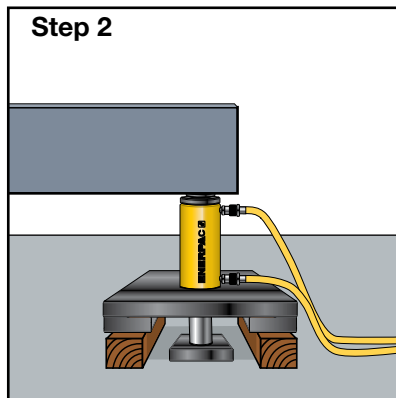
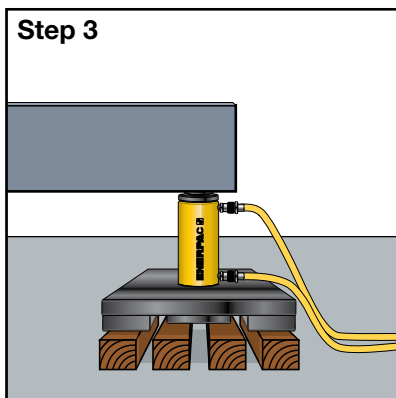
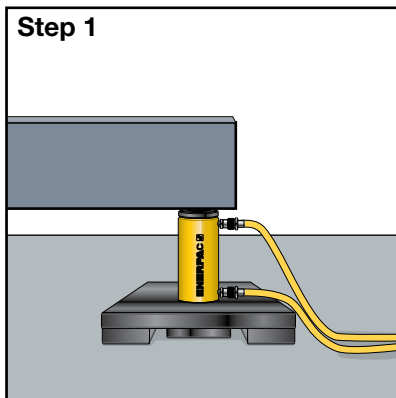

▲ Stage Lifting Sequence

Step 1: The Climbing Jack is placed on a solid support under the load (retracted plunger).

Step 2: Plunger extends, lifting the load and giving clearance to insert two outer blocks under the spreading plate.

Step 3: Plunger retracts, giving clearance to position the central blocks which will support the plunger plate for the next extension.

Step 4: Plunger extends, lifting the load, giving clearance to insert two new blocks, placed crosswise under the spreading plate.

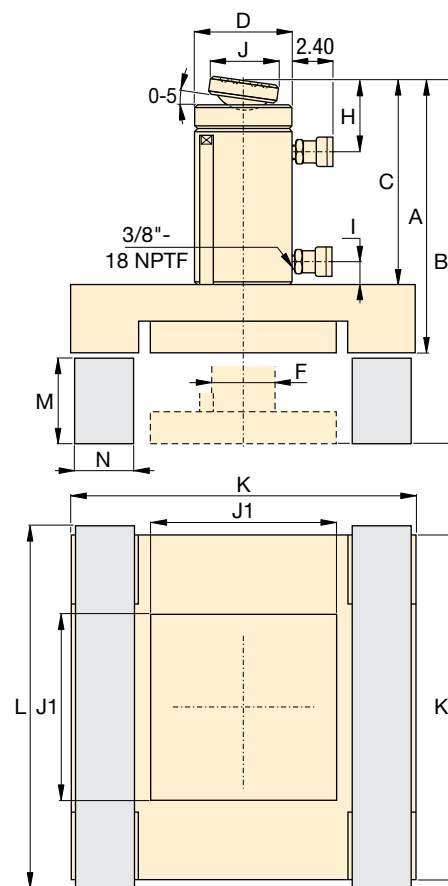

Cylinder Effective Area (in ²)	Oil Capacity (in ³)	Climbing Jack Dimensions (in)													Support Blocks * and Dimensions (in)			Wt. (lbs)	Model Number
		Push	Pull	Push	Pull	A	B	C	D	F	H	I	J	J1	K	Material	L		
11.04	3.33	67.80	20.44	15.98	21.89	12.52	5.00	3.11	2.24	1.42	1.97	9.45	20.28	Azobe	22.24	5.51	4.72	375	BLS506
20.66	9.64	136.57	63.77	17.52	23.86	13.50	6.97	3.74	2.99	0.94	2.80	12.99	26.38	Wood	28.35	5.91	6.30	695	BLS1006
30.71	14.79	188.56	90.80	18.58	24.57	14.57	8.00	4.49	3.70	1.54	5.12	9.06	18.70	Solid aluminum or steel	19.69	5.51	4.53	710	BLS1506
44.21	22.50	264.35	134.80	20.08	26.02	15.24	9.76	5.24	4.02	1.46	5.12	10.63	21.65		22.64	5.51	5.31	825	BLS2006

* Support blocks are not supplied by Enerpac.

▼ SCJ50, Enerpac Self-Locking Cube Jack



Incremental Lifting System With Automatic Mechanical Locking

- System is automatically mechanically locked after the lifting or lowering stroke
- Self-aligning steel cribbing blocks save time, improve side load resistance, and eliminate the need for wooden cribbing materials
- Jobs are completed more efficiently due to simplified operation sequence with 50% less cycles than climbing jacks
- End block with adjustable swivel saddle allows fine adjustment during set-up: 1.97-inch screw extension
- Can be operated with Enerpac's 10,000 psi hydraulic power units
- Maximum sideload 1.5% at full extension
- Lloyds witness tested to 125% of maximum working load

▼ Typical set-up with 4 Self-Locking Cube Jack and cribbing blocks to lift a transformer (hydraulic power pack and hoses not shown).

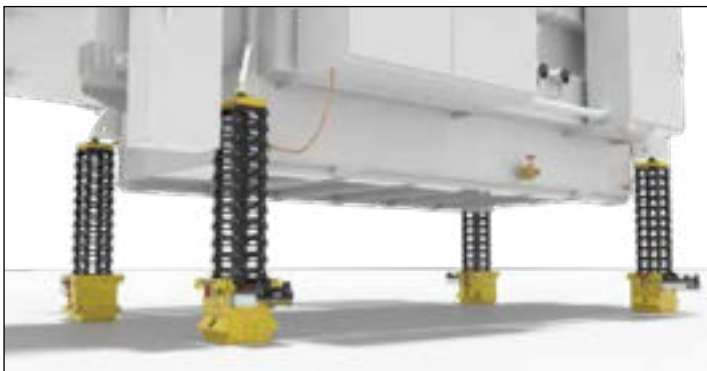

Why use Self-Locking Cube Jacks?

The Self-Locking Cube Jack is a safer, more efficient alternative to the jack-and-pack method with wooden cribbing.

The Cube Jack is derived from the proven Enerpac Jack-up System. The Cube Jack has a small footprint and is usable in confined spaces, providing heavy lift contractors with a stable lift up to 118.3 inch. The cribbing blocks are lightweight and can be handled manually.



Markets & Applications

Applications with a minimum starting height of 19 or 22 inches and requirement to lift up to 81 or 118 inches.

- Power Generation transformer jacking
- Mining - equipment maintenance
- Heavy Transport - vehicle unloading
- Oil & Gas - module jacking
- Construction - bridge jacking
- Industrial Movers - lifting, lowering and levelling of heavy equipment.

Self-Locking Cube Jacks



Self-Locking Cube Jacks

Easy-to-use, compact and portable jacking system that utilizes base lifting frames and self-aligning, lightweight steel cribbing blocks, instead of wooden cribbing materials.

Operation is simple:

1. Connect the Cube Jacks to the Enerpac Split-Flow Pump and select lifting mode on each base lifting frame.
2. Insert a cribbing block and actuate the Cube Jack until the cribbing block engages the lock mechanism.
3. Retract the jack and repeat the process until the desired lifting height is reached. For the lowering operation select lowering mode on each base lifting frame and reverse the process.

The Cube Jack End Block is equipped with an adjustable saddle for initial alignment with the load. All controls except for the main directional valve, which is on the hydraulic power unit, are included on the Cube Jack.

Manual cribbing block insertion

Cribbing blocks are easily managed by hand and the Cube Jack includes integrated fork pockets and lifting rings for effortless positioning.

Synchronous Lifting & Lowering

If synchronization is required, the Cube Jack can accommodate stroke sensors and be used with any Enerpac Computer Controlled Synchronous Lifting System.

SCJ Series



Capacity Per Cube Jack:

56 - 110 ton

Maximum Lifting Height:

81.4 - 118.3 inches

Maximum Operating Pressure:

10,000 psi

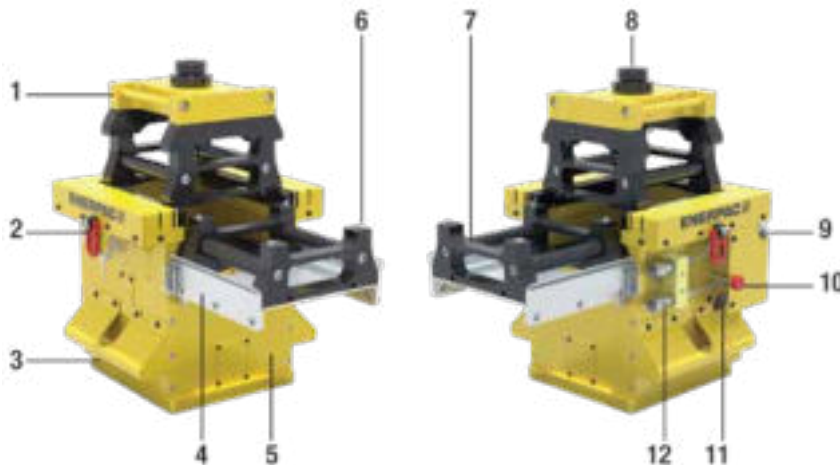

Self-Locking Cube Jacks

- | | |
|---------------------------------|---|
| 1 End block with tilting saddle | 7 Steel cribbing blocks |
| 2 Eye-bolts for hoisting | 8 Adjustable tilting saddle |
| 3 Forklift tabs | 9 Flow control |
| 4 Removable insert table | 10 Mode locking pin |
| 5 Cube Jack base frame | 11 Mode selector lever |
| 6 Locating pins | 12 Hydraulic connections
(Advance / Retract) |



▲ Cube Jack close-up of lifting and lowering valving mode and lock handle.

▼ Optional wire stroke sensor can provide stroke feedback to pump control.



▼ SCJ100, Enerpac Self-Locking Cube Jack



Incremental Lifting System With Automatic Mechanical Locking



Transportation Frame

Provided with purchase of each Cube Jack.

Provides storage and transport for base unit, end block, and all included cribbing blocks.



Lightweight Cribbing Blocks

Provided with purchase of each Cube Jack.

Spare cribbing blocks can be ordered separately.

Description	Model No.
1x Cribbing Block	SCJ5B
1x Cribbing Block	SCJ10B



Split-Flow Pumps

Enerpac recommend to use the SFP-Series Pumps with multiple outlets with equal oil flow.

For lifting and lowering applications on multiple points, Split-Flow Pumps are a far better alternative than using separately operated pumps.

- **Included with Cube Jack are:**
 - **Cube Jack Base Unit**
 - **End Block with Swivel Saddle**
 - **Multiple cribbing blocks: 11x on SCJ50
18x on SCJ100**
 - **Transportation Frame**
- **Cribbing blocks can be manually inserted into Cube Jack by one person**

▼ *Forklift tabs on Cube Jacks for easy transportation and positioning with a pallet truck. See dimensions D and I to select the right pallet truck size.*



▼ Self-Locking Cube Jacks

Lifting Capacity per Base Unit (ton)	Lifting Stroke (in)	Model Number	Maximum Sideload at Full Extension	Oil Capacity per Base Unit (in ³)	
				Advance	Retract
56	6.14	SCJ50	1.5%	75	38
110	6.14	SCJ100	1.5%	152	85

Self-Locking Cube Jack and Accessories

Basic Unit

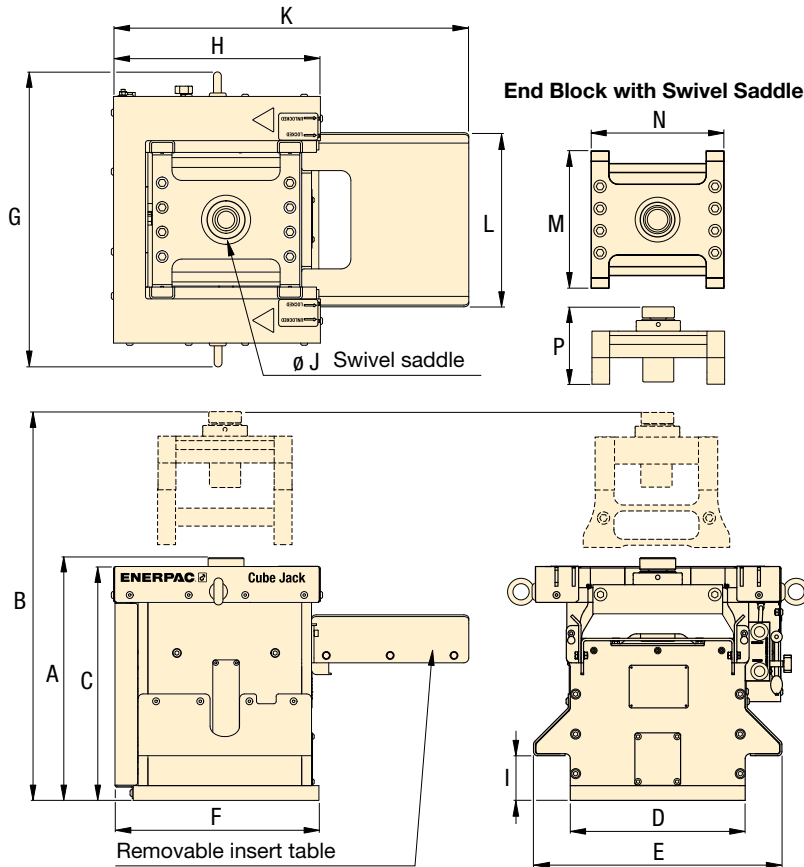

SCJ Series



Capacity Per Cube Jack:

56 - 110 ton

Maximum Lifting Height:

81.4 - 118.3 inches

Maximum Operating Pressure:

10,000 psi



▲ SCJ100 Self-Locking Cube Jack at maximum height of 118.3 inches with 18 cribbing blocks.

Cribbing Block

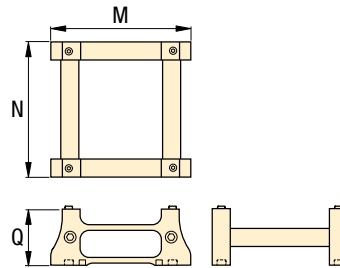

Base Unit		End Block		Cribbing Block		Transport Frame*	
Model Number	Weight (lbs)	Model Number	Weight (lbs)	Model Number	Weight (lbs)	Model Number	Weight (lbs)
SCJ50	794	SCJ5EB	88	SCJ5B	35	SCJ5F	243
SCJ100	1804	SCJ10EB	220	SCJ10B	51.7	SCJ10F	550

Dimensions (inches)																Model Number	
A	B	C	D	E	F	G	H	I	J	K	L	M	N	P			Q
														(min)	(max)		
19.4	81.4	18.7	14	19.9	17.4	21.9	16.9	3.6	4.92	28.6	13.8	11.8	12.2	6.9	8.9	4.9	SCJ50
22.0	118.3	20.7	19.9	25.8	25.0	30.4	23.5	4.0	6.69	41.2	19.8	17.7	18.1	7.4	9.4	4.9	SCJ100

* Dimensions Transport Frame L x W x H: SCJ5F: 36.25 x 33.5 x 34 inches
SCJ10F: 63 x 47.25 x 59 inches

▼ LH-Series, Low-Height Skidding System



- **Low starting height saves time and increases versatility**
- **Portable design allows for easy transport and setup**
- **System can push or pull load without relocating skidding cylinder**
- **Skid track sections bolt together to allow each setup to be customized as needed**
- **Replaceable PTFE skid pads lower the total cost of ownership**

Low Height Skidding System for Heavy Loads

The Ideal Low-Height Jack & Slide Solution



Skidding Systems

The Skidding System is comprised of a series of skid beams moved by hydraulic push-pull cylinders, travelling over a pre-constructed skid track.

A series of special PTFE-coated Teflon® pads are placed on the skid tracks to reduce friction. The push-pull cylinders are then connected by hydraulic hoses to our Split-Flow Pump. The Split-Flow Pump can be mounted on an optional pump cart for easy transport.

An optional storage and transport frame easily holds the equipment in between use.

▼ LH400, Low-Height Skidding System provides the service team with the ability to maneuver and transport a press frame.



Low-Height Skidding System, 400 Tons



Low-Height Skidding Jack Starter Kit - LH400SK

A complete starter kit is available to fit the needs of any jack and slide application.

This system comes with two skidding units that will support up to 400 tons in total. This kit will get the job done, but there are optional accessories available in addition (see pages 80-81).

Each skidding unit will have 1 push-pull unit, 2 skid beams and 5 skid tracks

LH400SK Starter Kit includes:	Model Number	Qty.
Push-Pull Unit (200 tons)	LHPP25	2x
Skid Beam A (3.3 feet)	LHSB1A	2x
Skid Beam B (3.3 feet)	LHSB1B	2x
Skid Track (3.3 feet)	LHST1	10x
Storage and Transport Frame	LHSF	1x

The Split-Flow Pump (to be ordered separately) has 2 outlets and can be easily towed on the pump cart. After the job is complete, components can be stowed on the included storage and transport frame.

LH Series



Skidding Capacity (with 2 push-pull units):

400 tons

Push-Pull Stroke:

23.5 inches

Maximum Operating Pressure:

10,000 psi

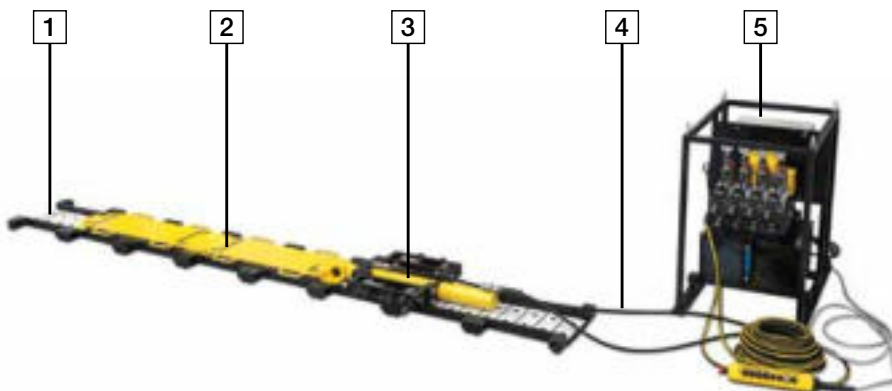

SFP-Series, Split-Flow Pump

Split-Flow pumps distribute an equal amount of hydraulic oil to a maximum of 8 outlets. Smart valve technology allows both controlled lifting and lowering of heavy loads.

Page: 132

▼ LH-Series Skidding System Requirements

1	Skid Track - LHST1	Required
2	Skid Beam - LHSB1A and LHSB1B	Required
3	Push-Pull Cylinder Unit - LHPP25	Required
4	Hydraulic Hoses	Required
5	Split-Flow Electric Pump	Required
6*	Track Support	Application Dependent
7*	Storage and Transport Frame - LHSF	Optional
8*	Pump Cart - LHPC	Optional

* not shown



Hydraulic Power Packs

Enerpac offers a comprehensive range of hydraulic power packs that are optimized for use with Skidding Systems.



LHPC Pump Cart

The LHPC pump cart easily tows pump around jobsite and can be used with all models of Split-Flow Pumps.

LH400 Low-Height Skidding System

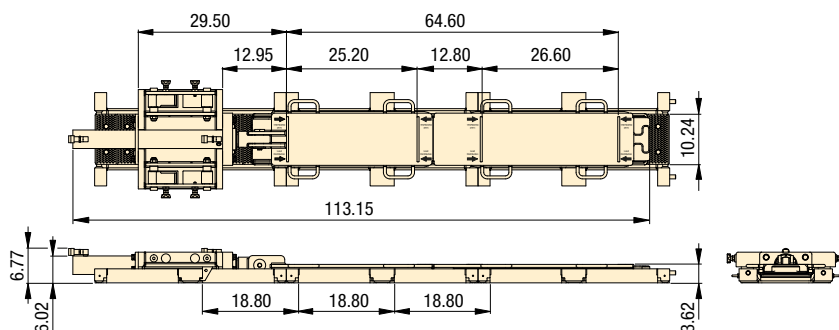

▼ LHPP25 Low-Height Push-Pull Unit



Push-Pull Unit

- Connects to first skid beam to push or pull load along skid track
- Easily reverse direction by switching reaction tabs
- Complies to ASME B30.1 and other safety standards

Maximum Capacity (tons)		Model Number	Stroke (inch)	Weight (lbs)
Push	Pull			
25	11	LHPP25	23.5	224

▼ LHSB1A and LHSB1B Skid Beams



Skid Beams

- Interlocks without any fasteners to slide load over skid track; skid beam A (LHSB1A) attaches to the push-pull unit skid beam B (LHSB1B) attaches to skid beam A
- Polished stainless steel skid surface
- Carrying handles for easy transport

Capacity (tons)	Model Number	Weight (lbs)
100	LHSB1A	145
100	LHSB1B	139

Low-Height Skidding Components

▼ LHST1 Skid Track



- Support the load for skidding operations
- Track sections bolt together
- Includes 9 pieces easily replaceable PTFE skid pads

Max.Cap. (per skid track)	Model Number	Track Length	Weight (including pads)
(tons)		(in)	(lbs)
100	LHST1	37.60	148

LH Series



Skidding Capacity (with 2 push-pull units):

400 tons

Push-Pull Stroke:

23.5 inches

Maximum Operating Pressure:

10,000 psi



Teflon® Pads

A series of special PTFE coated Teflon® pads are placed on the skid tracks.

The PTFE surface is matched with the skid beam and designed to achieve minimum friction coefficients. Replacement Teflon® pads come in packs of 12 pieces. Order model number **HSKSPS1**.



LHSF Storage and Transport Frame

- For easy storage and transport.
- Fits following components:

2x LLPP25 Push-Pull Unit

2x LHSB1A Skid Beam A

2x LHBS1B Skid Beam B

10x LHST1 Skid Tracks

▼ An LH400 Skidding System allows the maintenance team to transport transformers with access limitations.



▼ Details of push-pull unit of LH400.



▼ Low-Height Skidding System assembly (LH400).



▼ ETT 400 Turntable

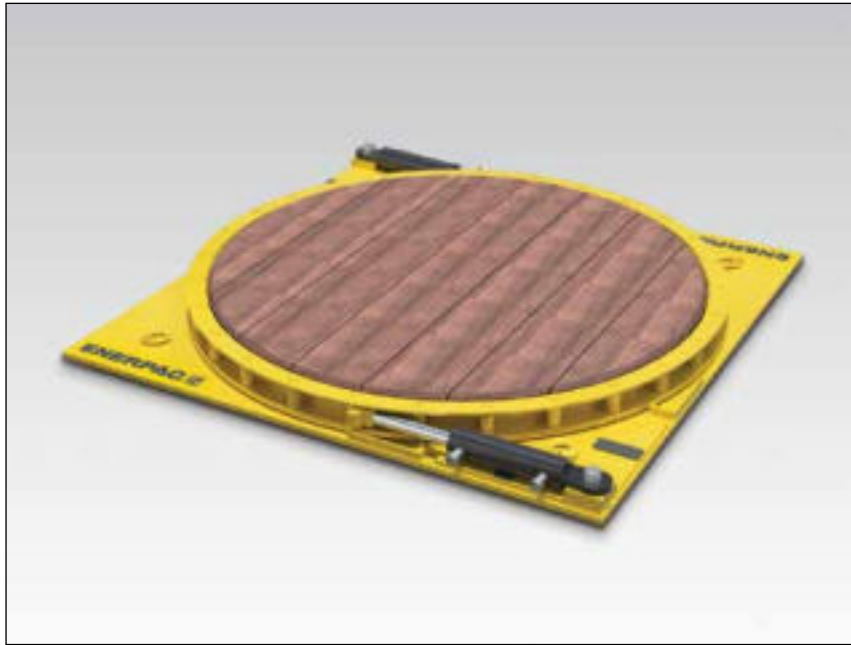

- Safe and controlled rotation of heavy loads
- Easily change rotation direction
- Dual capacity: 225 ton with one cylinder, 450 ton with two cylinders
- Compact size for use in applications with limited space
- Compatible with standard Enerpac pumps
- Hardwood surface

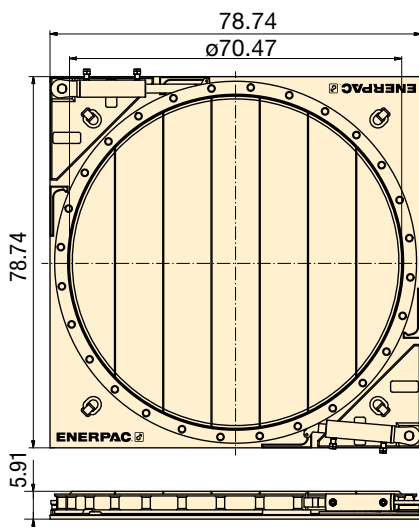

▼ SELECTION CHART

Maximum Load Capacity (ton)	Model Number	Cylinder Capacity * (ton)	Cylinder Oil Capacity * (in ³)		Number of Cylinders*	Rotation per Stroke (degrees)	Platform Diameter (in)	Wt. (lb)
			advance	retract				
225	ETT200	25	48.31	21	1	12.5	70.47	3748
450	ETT400	25	48.31	21	2	12.5	70.47	3803

* Per cylinder. Cylinder model number: **BRD259-ETT**

ETT Series

Maximum Capacity:
225 - 450 tons

Cylinder Capacity:
25 tons

Maximum Operating Pressure:
10,000 psi



Safe and Controlled Rotation

The ETT-Series is your solution for rotating heavy loads during, before or after a lifting and skidding operation.



SFP-Series, Split-Flow Pump

Split-Flow pumps distribute an equal amount of hydraulic oil to a maximum of 8 outlets. Smart valve technology allows both controlled lifting and lowering of heavy loads.

Page: 132



LH-Series, Low-Height Skidding

The ETT-Series is ideal in combination with our skidding systems, particular the LH-Series. Skidding and rotating in confined spaces is simplified.

Page: 360



Telescopic Hydraulic Gantries

The ETT-Series in combination with our hydraulic gantry SL-Series makes load handling in the most demanding situations easy.

Page: 364

INFRASTRUCTURE



◀ Custom cylinders used for incremental bridge launching systems.

BUILDING CONSTRUCTION



◀ Custom cylinders for jack and slide operations.

INFRASTRUCTURE



◀ Custom SyncHoist cylinders for placement of stadium roof trusses.

POWERGEN



◀ Custom double-acting Lock Nut cylinders with internal stroke sensors and an integrated load holding valve for lifting nuclear components.

INFRASTRUCTURE



◀ Custom cylinders with embedded sensors for bridge construction.

POWERGEN



◀ One of three custom SyncHoist cylinders used to place a 1,140-ton nuclear plant module.

Enerpac hydraulic pumps are available in over 1,000 different configurations. Whatever your high pressure pump needs are... speed, control, intermittent or heavy-duty performance... you can be sure that Enerpac has the pump to suit the application.

Featuring Hand, Battery, Electric, Air and Gasoline powered models, with multiple reservoir and valve configurations, Enerpac offers the most comprehensive high pressure pump line available.

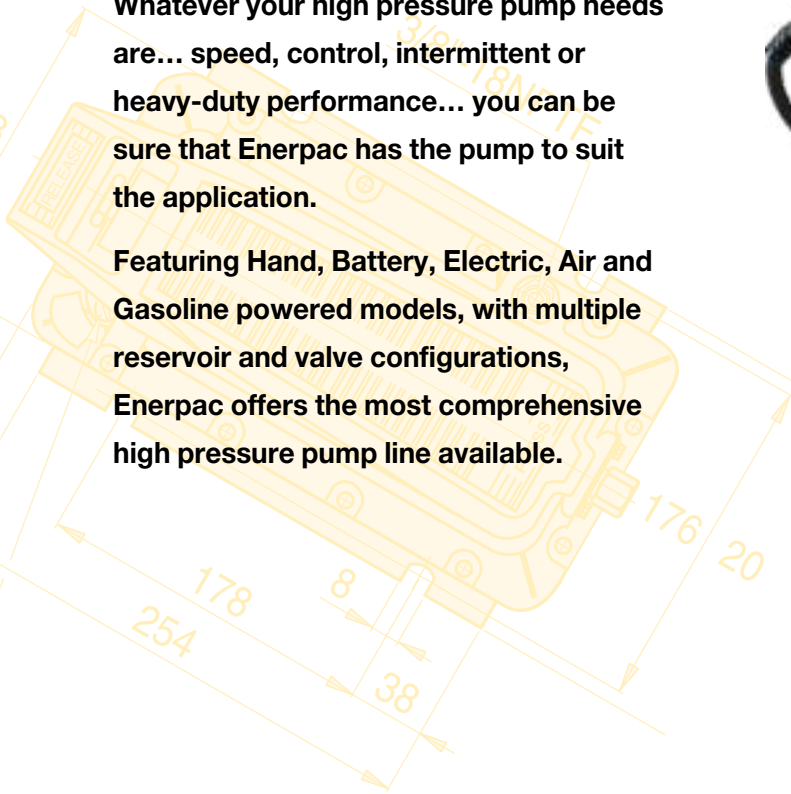

Pump Selection

For help in selecting the correct pump for your application, please review our **“Yellow Pages”**. If you require further assistance, contact the Enerpac office located near you.

Page: 406























Torque Wrench Pumps

System matched air and electric pumps provide control to operate Enerpac Torque Wrenches.

Page: 295

Pumps and Directional Control Valves Section Overview

Power Source	Pump Types	Maximum Reservoir Capacity	Max. Flow at Rated Pressure (in ³ /min)	Series	Image	Page
Manual	Lightweight Hand Pumps Exclusively from Enerpac	155 in ³	0.15 (in ³ /stroke)	P		86 ▶
	ULTIMA Steel Hand Pumps Low-Pressure Hand Pumps	453 in ³ 200 in ³	0.29 0.58 (in ³ /stroke)	P P		88 ▶ 90 ▶
	Foot Pump For Hands-Free Operation	38 in ³	0.15 (in ³ /stroke)	P		92 ▶
	Multifluid Hand Pumps Pumping Fluids up to 14,500 psi	–	1.28 (in ³ /stroke)	MP		93 ▶
	Ultra-High Pressure Hand Pumps Pressure up to 40,000 psi	60 in ³	0.15 (in ³ /stroke)	P, 11		94 ▶
Battery	Battery Powered Hydraulic Pumps Cordless Hydraulic Power	120 in ³	15	XC		96 ▶
	Cordless Hydraulic Pumps High-Performance Battery Power	60-120 in ³	32	ZC		98 ▶
Electric	Economy Series Compact and Portable	1 gal.	20	PU		100 ▶
	Electric Hydraulic Pumps, E-Pulse® The Heart of the System	0.8 gal.	32	E		102 ▶
	Z-Class Portable and Powerful	10 gal.	60 200	ZU4 ZE		104 ▶ 112 ▶
	8000-Series The Maximum Flow Pump	25 gal.	462	PEM PER		118 ▶
Air	Air Hydraulic Pumps Single and Twin-Air Motor	80 in ³ 2 gal.	8 9	PA PAM		120 ▶ 121 ▶
	Turbo II Air Hydraulic Pumps Compact Air Over Hydraulic	305 in ³	10	PA		122 ▶
	XA-Series Air Hydraulic Pumps Control and Ergonomics	122 in ³	15	XA		124 ▶
	ZA4 Air Hydraulic Pumps The Standard for Air-Hydraulic Pumps	10 gal.	80	ZA		126 ▶
Gasoline	ZG5/ZG6 Gasoline Hydraulic Pumps Gas Powered High-Flow Pumps	10 gal.	200	ZG5 ZG6		128 ▶ 130 ▶
	8000-Series Gasoline Pumps For the Largest Jobs	25 gal.	1.5 (gal/min)	EGM		131 ▶
Controlled	Split-Flow Pumps Multi-point Lifting & Lowering	40 gal.	153	SFP		132 ▶
	Synchronized Lifting System Computer Controlled Monitoring for Precise Lifting	66 gal.	292	EVO		136 ▶
	Directional Control Valves					139 ▶

▼ Pumps shown, from top to bottom: P802, P842, P202, P142



Exclusively from Enerpac

i Cylinder Matching Chart
 For help in selecting the correct hand pump for your application, please refer to the Cylinder Matching Chart located in the “Yellow Pages”.

Page: 402

i Speed Chart
 To determine how a specific pump will operate your cylinder, see the Pump/Cylinder Speed Chart in the “Yellow Pages”.

Page: 409

- Lightweight and compact design
- Durable glass-filled nylon reservoir and nylon encapsulated aluminum pump base for maximum corrosion resistance
- Two-speed operation on most models reduces handle strokes by as much as 78% over single speed pumps
- Lower handle effort to minimize operator fatigue
- Integral 4-way valve on P842 for operation of double-acting cylinders
- Handle lock and lightweight construction for easy carrying
- Large oil capacities to power a wide range of cylinders or tools
- Non-conductive fiberglass handle for operator safety
- Internal pressure relief valve for overload protection



Tank Kits

When a return-to-tank port is required, the Tank Kits provide a 7/16"-20 port at the rear of the reservoir.

PC20	Fits P141, P142
PC25	Fits P202, P391, P392



LX101 Hand Pump Oil

A medium viscosity oil specially formulated for hand pumps. Performs well in low temperatures and requires less pumping effort than standard Enerpac HF blue oil.

Page: 152

▼ P392 in action with RC256 cylinders.



Pump Type	Usable Oil Capacity (in ³)	Model Number	Pressure Rating*		Oil Displacement per Stroke		Max. Handle Effort (lbs)
			(psi)		(in ³)		
			1 st stage	2 nd stage	1 st stage	2 nd stage	
Single speed	20	P141	N/A	10,000	N/A	0.055	72
	55	P391	N/A	10,000	N/A	0.151	85
Two speed	20	P142**	200	10,000	0.221	0.055	78
	55	P202	200	10,000	0.221	0.055	63
	55	P392**	200	10,000	0.687	0.151	93
	155	P802	400	10,000	2.40	0.151	95
	155	P842***	400	10,000	2.40	0.151	95

* Contact Enerpac for applications where operating pressure is less than 10% of pressure rating.

** Available as set, see note on top of next page.

*** For use with double-acting cylinders.

Lightweight Hand Pumps

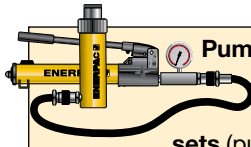

Pump and Cylinder Sets
Pumps marked with an ** are available as sets (pump, cylinder, gauge, couplers and hose) for your ordering convenience.

Page: **62**

P Series



Reservoir Capacity:
20 - 155 in³

Flow at Rated Pressure:
0.055 - 0.15 in³/stroke

Maximum Operating Pressure:
10,000 psi



Hoses

Energac offers a complete line of high-quality hydraulic hoses. To ensure the integrity of your system, specify only genuine Energac hydraulic hoses.

Page: **148**



GA45GC Gauge Adaptor

Protect yourself from system overloading by simply ordering one part number for a pre-assembled gauge, adaptor block and coupler.

Page: **162**



Aluminum Reservoir

For applications where composite reservoirs may not be suitable, the **P392AL** utilizes an extruded aluminum reservoir. Also included is a second handle for two-hand use. Contact Energac for details.

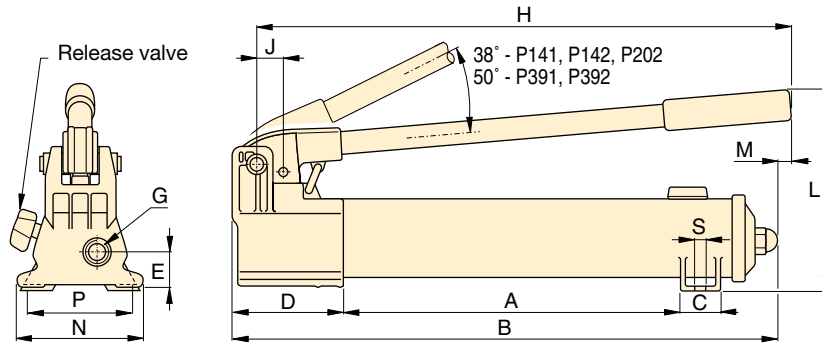

P141, P142, P202, P391, P392

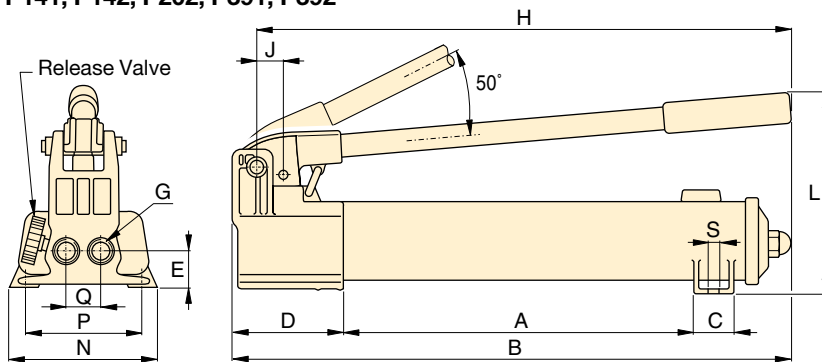

P802

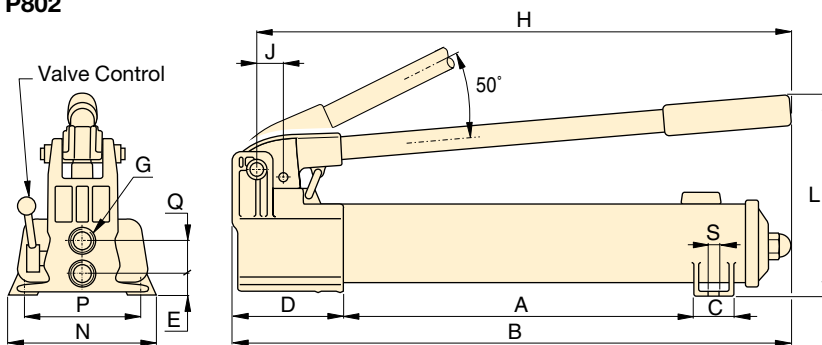

P842

Piston Stroke	Dimensions (in)															Weight (lbs)	Model Number
	(in)	A	B	C	D	E	G	H	J	L	M	N	P	Q	S		
0.50	7.31	13.25	1.13	3.37	1.13	1/4"-18 NPTF	12.56	0.75	5.63	-	3.75	3.25	-	0.28	4.5	P141	
1.00	13.56	21.00	1.44	3.93	1.31	3/8"-18 NPTF	20.56	1.19	7.00	0.63	4.75	-	-	-	9.0	P391	
0.50	7.31	13.25	1.13	3.37	1.13	1/4"-18 NPTF	12.56	0.75	5.63	-	3.75	3.25	-	0.28	5.3	P142**	
0.50	13.56	20.06	1.44	3.37	1.13	1/4"-18 NPTF	15.75	0.75	5.69	0.63	3.75	-	-	-	7.5	P202	
1.00	13.56	21.00	1.44	3.93	1.31	3/8"-18 NPTF	20.56	1.19	7.00	0.63	-	-	-	-	9.0	P392**	
1.00	13.30	21.75	1.78	5.25	1.39	3/8"-18 NPTF	20.75	2.19	9.00	-	7.12	6.02	1.40	0.41	18.0	P802	
1.00	13.30	21.75	1.78	5.25	0.81	3/8"-18 NPTF	20.75	2.19	9.00	-	7.12	6.02	1.44	0.41	22.0	P842***	

▼ Shown from left to right: P77, P80, P84, P801, P39



- Reduced handle effort and ergonomic grip for less operator fatigue
- Two-speed operation for fast and easy operation (except P39)
- Vent free reservoir eliminates spills
- Quick grip handle allows for easy transport
- Integral reservoir over-pressurization protection
- All steel construction, chrome plated plunger and wiper system for durable, long lasting performance
- 4-way valving on the P84 and P464 for operation of double-acting cylinders

▼ In the absence of a power supply, the P80 Hand Pump offers a powerful solution.



The Solution for Tough Jobs



Two-Speed Pumps

Recommended for applications where cylinder plunger must advance rapidly to contact load, and applications where greater oil capacities are required, such as multiple cylinder hook-ups.



Foot Pump Conversion Kits

Convert your P39, P77, P80, or P801 to foot power with the PC11 Kit.

Includes instructions for easy conversion.



GA45GC Gauge Adaptor

Protect yourself from system overloading by simply ordering one part number for a pre-assembled gauge, adaptor block and coupler.

Page: 162



4-Way Control Valve

P84 and P464 feature a manual 4-way control valve, designed for use with one double-acting or two single-acting cylinders. For system set-up information:

Page: 404

Pump Type	Usable Oil Capacity (in ³)	Model Number	Pressure Rating*		Oil Displacement per Stroke (in ³)		Max. Handle Effort (lbs)
			1 st stage	2 nd stage	1 st stage	2 nd stage	
Single	41	P39	N/C	10,000	N/C	0.15	85
Two-speed	41	P77	500	10,000	1.00	0.15	88
	134	P80**	500	10,000	1.00	0.15	77
	250	P801	500	10,000	1.00	0.15	77
	134	P84***	500	10,000	1.00	0.15	77
	453	P462	200	10,000	7.69	0.29	110
	453	P464***	200	10,000	7.69	0.29	110

* Contact Enerpac for applications where operating pressure is less than 10% of pressure rating.

** Available as a set, see note on next page.

*** For use with double-acting cylinders.



Speed Chart

To determine how a specific pump will operate your cylinder, see the Pump/Cylinder Speed Chart in the "Yellow Pages".

Page: 409

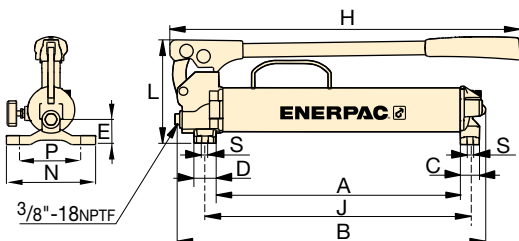

P39, P77

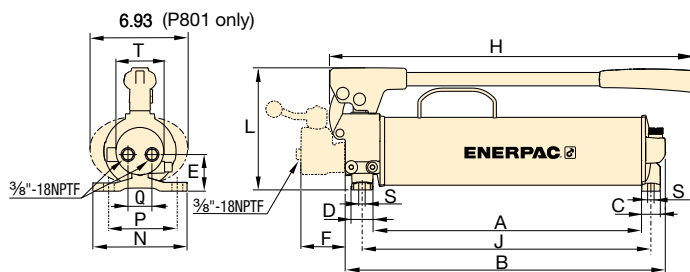

P80, P801, P84

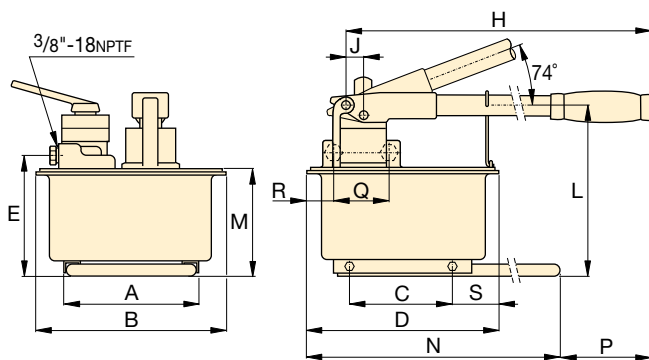

P462, P464

P Series



Reservoir Capacity:
41 - 453 in³

Flow at Rated Pressure:
0.15 - 0.29 in³/stroke

Maximum Operating Pressure:
10,000 psi



Extra Capacity Hand Pumps

P462 and P464 feature extra-large reservoirs and a high first-stage flow rate.

These pumps are ideally suited for powering high-capacity cylinders.

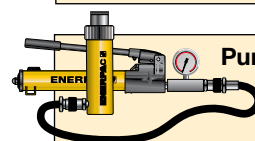

Pump and Cylinder Sets

P80 is also available as a set (pump, cylinder, gauge, couplers and hose) for your ordering convenience.

Page: 62



Cylinder Matching Chart

For help in selecting the correct hand pump for your application, please refer to the Cylinder Matching Chart located in the "Yellow Pages."

Page: 402

Piston Stroke	Dimensions (in)																	Weight (lbs)	Model Number
	(in)	A	B	C	D	E	F	H	J	L	M	N	P	Q	R	S	T		
1.00	15.09	18.91	1.18	1.38	1.48	-	21.63	16.37	6.39	-	5.51	4.37	-	-	0.33	-	13.6	P39	
1.00	15.39	19.19	1.18	1.38	1.86	-	21.63	16.67	6.39	-	5.51	4.37	-	-	0.33	-	15.6	P77	
1.00	16.83	20.12	1.18	1.38	2.17	-	23.50	18.11	7.65	-	5.91	4.76	1.65	-	0.33	2.93	23.6	P80**	
1.00	16.83	20.12	1.18	1.38	2.17	-	23.50	18.11	7.65	-	5.91	4.76	1.65	-	0.33	2.93	31.0	P801	
1.00	16.83	20.06	1.18	1.38	2.30	2.77	22.78	18.11	7.65	-	5.91	4.76	1.50	-	0.33	2.93	26.0	P84***	
1.50	8.25	12.13	6.42	12.63	7.68	-	26.44	.98	10.63	6.89	25.6	3.63	-	-	3.13	-	61.0	P462	
1.50	8.35	12.13	6.42	12.63	7.68	-	26.44	.98	10.63	6.89	25.6	3.63	3.50	2.68	3.13	-	61.0	P464***	

▼ Shown from left to right: P25, P51, P18



When Less Than 10,000 psi is All You Need

- P25 and P50 pump oil in both forward and reverse handle movement improving overall efficiency, ideal when mounting space is restricted
- External load-release valve
- Internal pressure-relief valve for overload protection
- For use with single-acting cylinders and tools
- P18 vertical operation requires pump head facing down
- P25, P50 vertical operation requires pump vent side facing up
- P51 for horizontal operation only



LX101 Hand Pump Oil

A medium viscosity oil specially formulated for hand pumps. Performs well in low temperatures and requires less pumping effort than standard Enerpac HF blue oil.

Page: 152



GA45GC Gauge Adaptor

Protect yourself from system overloading by simply ordering one part number for a pre-assembled gauge, adaptor block and coupler.

Page: 162

▼ P18 hand pump used for locking the rotating table for marble polishing.



Pump Type	Usable Oil Capacity (in ³)	Model Number	Pressure Rating (psi)	Oil Displacement per Stroke (in ³)	Max. Handle Effort (lbs)
Single-speed	18	P18	2,850	0.16	34
	200	P25	2,500	0.58	60
	200	P50	5,000	0.29	60
	50	P51	3,000	0.25	61

Low Pressure Hand Pumps

P Series



Reservoir Capacity:
18 - 200 in³

Flow at Rated Pressure:
0.16 - 0.58 in³/stroke

Maximum Operating Pressure:
2,500 - 5,000 psi

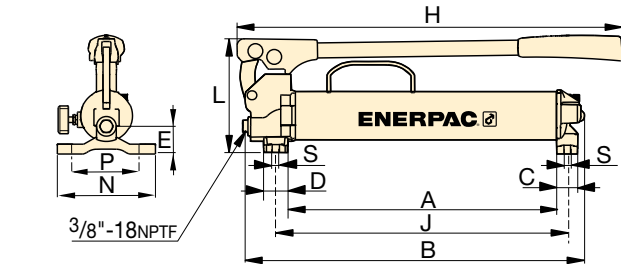

P18

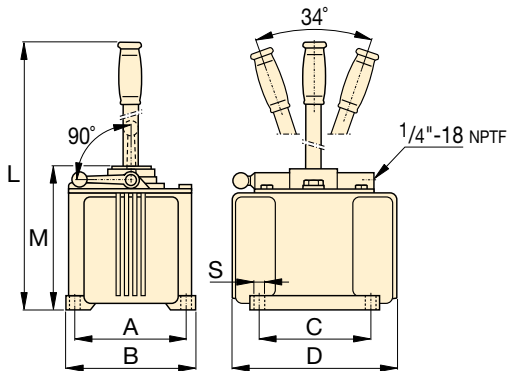

P25, P50

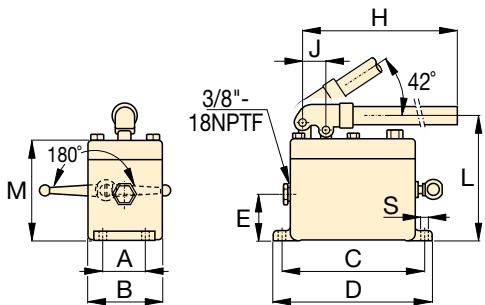

P51

P51 hand pumps used with RC-series cylinders to keep wooden layers under pressure during lamination of plates.



Hoses

Enerpac offers a complete line of high-quality hydraulic hoses. To ensure the integrity of your system, specify only genuine Enerpac hydraulic hoses.

Page: 148



MP-Series Multifluid Hand Pumps

Corrosion resistant hand pumps for low pressure filling and high pressure testing applications, suitable for a wide range of fluids.

Page: 93



Piston Stroke	Dimensions (in)												Weight (lbs)	Model Number
	(in)	A	B	C	D	E	H	J	L	M	N	P		
1.00	8.70	12.44	1.18	1.38	1.48	15.17	9.98	6.39	-	5.51	4.37	0.33	11	P18
1.50	6.00	6.82	6.00	9.43	-	-	-	26.94	7.88	-	-	0.40	36	P25
1.50	6.00	6.82	6.00	9.43	-	-	-	26.94	7.88	-	-	0.40	37	P50
1.00	2.06	3.63	7.12	7.88	2.25	24.00	1.16	6.31	5.06	-	-	0.34	12	P51

▼ Shown: P392FP



P Series

Reservoir Capacity:

38 in³

Flow at Rated Pressure:

0.151 in³/stroke

Maximum Operating Pressure:

10,000 psi

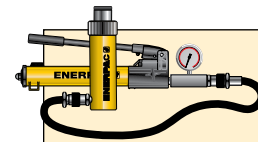

Pump and Cylinder Sets

The P392FP is available as **sets** (pump, cylinder, gauge, couplers and hose) for your ordering convenience.

Page: 92

- Robust, durable and compact
 - Steel frame for maximum stability
 - Steel pumping handle
 - Aluminum reservoir
- Foot pedal lock and lightweight construction for portability
- Two-speed operation reduces foot pedal strokes
- Large foot-pad release valve for controlling load descent
- Internal pressure relief valve for overload protection



Hoses

Enerpac offers a complete line of high-quality hydraulic hoses. To ensure the integrity of your system, specify only genuine Enerpac hydraulic hoses.

Page: 148

▼ P392FP offers the advantage of hands-free operation to handle and control the tool or cylinder.

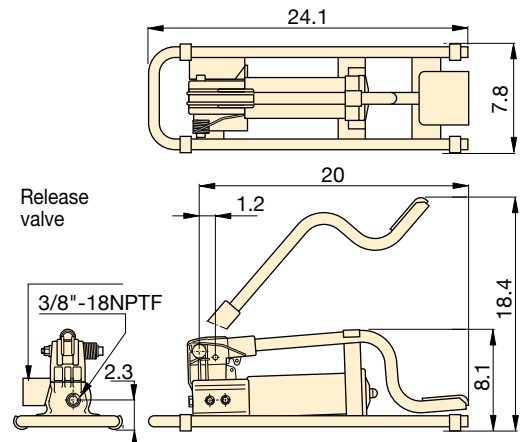

Usable Oil Capacity (in ³)	Model Number	Pressure Rating (psi)		Oil Displacement per Stroke (in ³)		Max. Handle Effort (lbs)	Piston Stroke (in)	Weight (lbs)
		1st stage	2nd stage	1st stage	2nd stage			
30	P392FP *	200	10,000	0.687	0.151	125	1	16

* Available as set, see note on this page.

MP-Series, Multifluid Hand Pumps

▼ Shown: **MP110**



MP Series

Reservoir Capacity:

2 gallon (optional)

Flow at Rated Pressure:

0.12 - 1.28 in³/stroke

Maximum Operating Pressure:

1,500 - 14,500 psi



Optional Reservoir Kit

The two-gallon reservoir kit **MP10T*** includes tank with skid frame, top plate with reservoir seal, suction pipe and mounting bolts. Useable oil capacity is 1.5 gal.

*For use with mineral oil applications only.



Also available is model number **11-400**.

Page: **94**

- Superior corrosion resistance
- Impregnated aluminum anodized pump housing with stainless steel internal pumping components
- Standard Nitrile seals – excellent for demineralized water, oil/water emulsions, water glycols, mineral oils, hydraulic fluids
- Custom EPDM seals available for use with Skydrol® or brake fluids
- Two-speed pumps up to 14,500 psi pressure
- Externally adjustable pressure-relief valve
- 1/4" NPTF gauge port

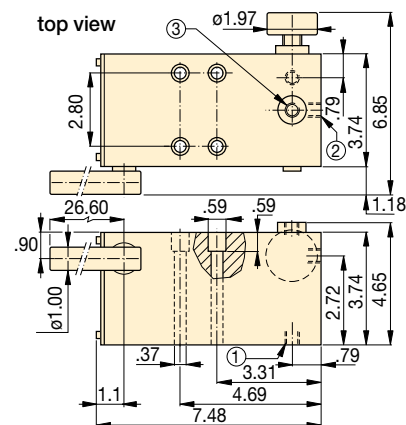

MP110, 350, 700, 1000

- ① Suction / Tank return port 3/8"-18 NPTF
- ② Pressure port 3/8"-18 NPTF
- ③ Gauge port 1/4"-18 NPTF

▼ MP-Series pumps are ideal for testing and filling applications.

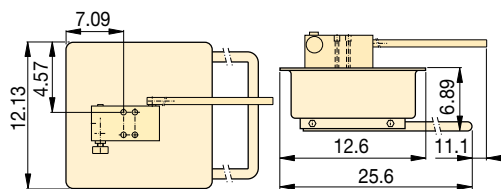

MP10T

Pump Type	Usable Oil Capacity (in ³)	Model Number	Pressure Rating (psi)		Oil Displacement per Stroke (in ³)		Max. Handle Effort (lbs)	Piston Stroke (in)	Weight (lbs)
			1st stage	2nd stage	1st stage	2nd stage			
Two Speed	*	MP110	500	1500	3.2	1.28	99	1.04	14.5
	*	MP350	500	5000	3.2	0.43	99	1.04	14.5
	*	MP700	500	10,000	3.2	0.18	99	1.04	14.5
	*	MP1000	500	14,500	3.2	0.12	99	1.04	14.5

Note: MP-Pump includes 0.060 in. thick gasket for reservoir mounting.

* MP-Series pumps require the use of an external reservoir.

▼ Shown from left to right: 11-100, P2282



Ultra-High Pressure up to 40,000 psi

- Two-speed operation on the P2282 allows for faster fill, reducing cycle times for many testing applications
- 303 Stainless steel construction on the 11-100 and 11-400 models enable use with many different fluids, such as distilled water, alcohol, diesters, silicones, soluble oils and petroleum
- Large release knob for improved control of pressure release
- Outlet ports are 3/4"-16 cone for 40,000 psi rating



2-Way Shut-Off Valve 72-750

For 40,000 psi applications requiring a shut-off valve or gauge snubber. Made of 318 Stainless Steel and utilizing 0.38-inch cone fittings, it is the perfect selection for use with your Ultra-High Pressure Hand Pump.



Test System Gauges

Ideal for monitoring pressure in your hydraulic circuit, Test System Gauges, such as the T6010L, are available with cone threads or NPTF threads and in a variety of pressure ranges.

Page: 160

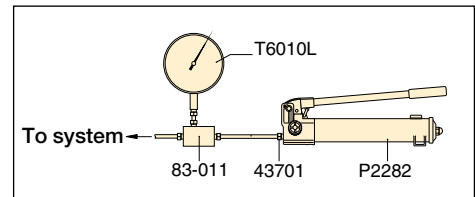

▲ Typical Test System

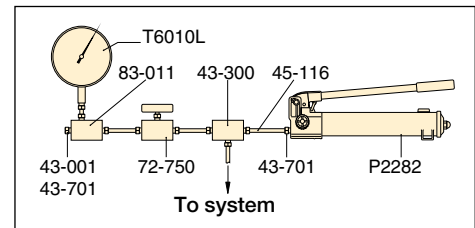

▲ Test System with Gauge and Snubber

Cone Seal

Stainless Steel High Pressure fittings seal on a "cone" surface and do not require pipe sealer. The Gland Nut holds the sleeve and tubing tight against the cone surface to provide a 40,000 psi seal.

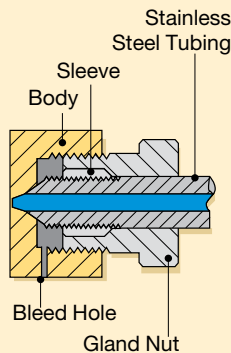

Pump Type	Usable Oil Capacity (in ³)	Model Number	Pressure Rating* (psi)		Oil Displacement per Stroke (in ³)		Max. Handle Effort (lbs)
			1st stage	2nd stage	1st stage	2nd stage	
Two-speed	60	P2282	200	40,000	0.99	0.037	106
Single-speed	45	11-100	N/C	10,000	N/C	0.152	120
	45	11-400	N/C	40,000	N/C	0.038	120

* Contact Enerpac for applications where operating pressure is less than 10% of pressure rating.

Ultra High-Pressure Hand Pumps

▼ Optional Ultra-High Pressure Fittings and Tubing

Description	Connection	Model No.
40,000 psi		
Gland Nut Plug	0.38" cone	43-001
Elbow	0.38" cone	43-200
Tee	0.38" cone	43-300
Gauge Tee	0.38" cone side/ 0.25" cone gauge port	43-301
Gauge Adaptor	0.38" cone side/ 0.25" cone gauge port	83-011
Coupling	0.38" cone	43-400
Cross	0.38" cone	43-600
Gland Nut with Sleeve	0.38" cone	43-701
Gauge Connector	0.25" cone	43-704
Tubing	4" tube, O.D. 0.38" * 8" tube, O.D. 0.38" * 12" tube, O.D. 0.38" *	45-116 45-126 45-136
WARNING: Maximum working pressure: 10,000 psi only		
Adaptor	0.38" F cone to 1/4" M NPTF 0.38" F cone to 3/8" M NPTF	41-146 41-166
Adaptor	0.38" F cone to 1/4" F NPTF 0.38" F cone to 3/8" F NPTF	41-246 41-266
Adaptor	0.38" M cone to 3/8" F NPTF	41-366

Note: 0.25" cone fittings use 9/16"-18 threads, 3/8" cone fittings use 3/4"-16 threads.

* Actual tubing lengths are 0.75" less than nominal size shown. These dimensions make distance between centers of valves and fittings multiples of 4" spaces.

P/11 Series



Reservoir Capacity:

45 - 60 in³

Flow at Rated Pressure:

0.037 - 0.152 in³/stroke

Maximum Operating Pressure:

10,000 - 40,000 psi



Ultra-High Pressure pumps DO NOT have an internal safety pressure relief valve.



Stainless Steel Construction

Ultra-high pressure fittings feature all stainless-steel construction except adaptor 41-366, which features nickel plated carbon steel construction.

11-100*, 11-400

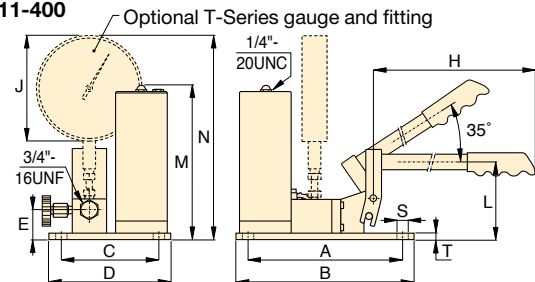

*NOTE: Maximum operating pressure for model 11-100 is 10,000 psi.

P2282

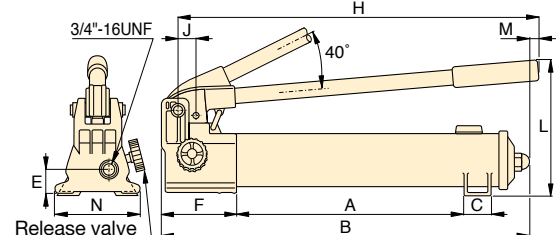

Piston Stroke	Dimensions (in)														Weight (lbs)	Model Number
	(in)	A	B	C	D	E	F	H	J	L	M	N	S	T		
1.00	13.56	22.00	1.40	-	1.24	5.25	20.75	1.16	9.00	0.28	4.74	-	-	14	P2282	
0.78	9.45	10.50	5.98	7.00	1.77	-	25.00	6.41	4.50	9.33	12.38	0.31	0.37	22	11-100	
0.78	9.45	10.50	5.98	7.00	1.77	-	25.00	6.41	4.50	9.33	12.38	0.31	0.37	22	11-400	

▼ Shown: XC1201M



- **Lightweight design with integrated handle and carrying strap for portability**
- **Bladder reservoir prevents contamination and allows pump usage in any position**
- **Powerful ½ horsepower motor and 28-volt Lithium-Ion battery deliver exceptional speed and run time**
- **High-strength fiberglass reinforced composite shroud for superior durability in demanding job site environments**
- **Cordless technology eliminates tripping hazards found in other electric or air powered pumps**
- **Available in torque wrench, dump and hold, single-acting and double-acting valve configurations**



Performance of a Powered Pump

Portability of a Hand Pump



GA45GC Gauge Adaptor

Protect yourself from system overloading by simply ordering one part number for a pre-assembled gauge, adaptor block and coupler.

Page: 162



28-Volt Battery

The XC28V with Lithium-Ion technology for maximum battery performance.



Roll Cage

Optional Roll Cage XC-Series pumps. Please order model number **XCRCTK**.



Interactive Pendant

An interactive pendant is available on the **XC1302S** dump and hold models and **XC1502T** torque wrench

models. Operation, programming, and diagnostic status are provided to the user with yellow, green, and red LED as well as vibration pulses.

The **XC1302S** models can easily toggle between "jog operation" to "dump system pressure" and the **XC1502T** models allow "manual" and "auto cycle" mode.

◀ Power and simplicity for the toughest jobs.

Cordless Hydraulic Pump



XC-Series Cordless Hydraulic Pump

The XC-Series cordless pump is ideal for jobs that require a combination of portability, speed, and safety. These cordless pumps are perfect for remote locations without access to power, but also indoors where trip hazards, ergonomics or size is a concern. The XC-Series cordless pump is compatible with all Enerpac hydraulic tools and small to medium sized cylinders.

The Lithium-Ion battery provides superior run time.*

- 279 cuts of 3/8 inch reinforcing bar using the WHC750 Cutter
- 112 lifts with the WR5 Spreader
- 44 splits on 1-inch, grade 8 nuts using the NC3241 Nut Splitter
- 28 lifts of an RC104

*Actual number of cycles per charge will vary depending on condition of tool, battery and ambient conditions. Battery life with double-acting tools is approximately 75% of that for comparable, single-acting tools.

XC Series



Reservoir Capacity:
60 - 120 in³

Flow at Rated Pressure:
15 in³/min.

Maximum Operating Pressure:
10,000 psi

- ① Outlet "Advance" Port
- ② Oil Fill (must use funnel)
- ③ User Adjustable Relief Valve Access Port
- ④ Directional Control Valve *
- ⑤ Shoulder Strap Connection Points
- ⑥ Safety Lock Feature *
- ⑦ On/Off Switch *
- ⑧ Inlet "Retract" Port (double-acting models only)

* Single-acting and double-acting models only

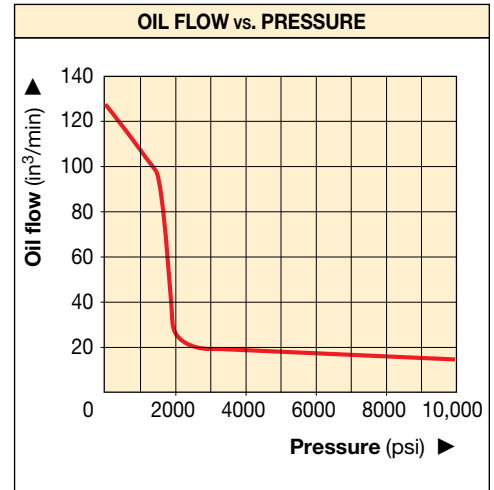
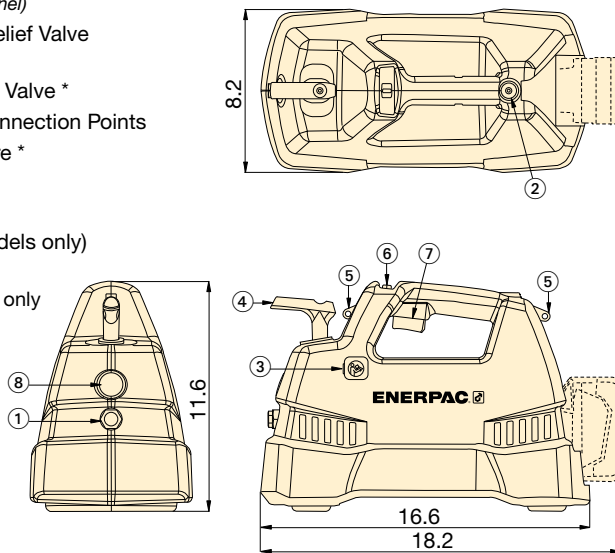

Battery Charger

1-hour quick charger.

XC115VC	115 VAC
XC230VC	230 VAC

▼ Take the battery pump anywhere without power cords or air hoses.



Pump Types (Used with Cylinder)	Oil Capacity (in ³)	Model Number*	Output Flow Rate (in ³ /min)			Valve Function	Charger Voltage (VAC)	Wt. ³⁾ (lbs)
			No Load	2000 psi	10,000 psi			
Single-acting	60	XC1201MB ¹⁾	125	30	15	3-way, 2-pos.	115	21.9
	120	XC1202MB	125	30	15			23.8
	60	XC1201ME ¹⁾	125	30	15	3-way, 2-pos.	230	21.9
	120	XC1202ME	125	30	15			23.8
	60	XC1201M ²⁾	125	30	15	3-way, 2-pos.	-	21.9
	120	XC1202M ²⁾	125	30	15			23.8
Single-acting	120	XC1302SB	125	30	15	Dump and Hold	115	25
	120	XC1302SE	125	30	15			230
	120	XC1302S ²⁾	125	30	15		-	25
Double-acting	60	XC1401MB	125	30	15	4-way,	115	22.3
	120	XC1402MB	125	30	15	3-pos.		24.2
	60	XC1401ME	125	30	15	4-way,	230	22.3
	120	XC1402ME	125	30	15	3-pos.		24.2
	60	XC1401M ²⁾	125	30	15	4-way,	-	22.3
	120	XC1402M ²⁾	125	30	15	3-pos.		24.2

1) Available as a cylinder-pump set, see page 62. 2) Batteries and charger not included.

3) Includes oil and battery

* "E" suffix indicates pumps have 230V chargers with European plug and CE CMC compliant.

▼ Shown: ZC3308JE



Z

Tough.
Dependable.
Innovative.

CLASSIC

High-Performance Battery Power

Productivity, Performance, Safety

- High-flow cordless solution saves users time and money by eliminating the need for using a generator and extension cords
- Brushless 1.4 hp motor and 3-stage pump maximizes pump and tool productivity while minimizing heat buildup and downtime
- The Lithium-Ion battery provides superior run time, even under extreme job site conditions, running approximately 50 cycles on a RC1006 and approximately 90 cycles on a RC504 cylinder on a single charge
- Convenient 10 ft. pendant cord for hassle-free operation
- Reduce noise level, 80 dba maximum
- Zero emission hydraulic power pack



Charger	
ZC115VC	115V
ZC230VC	230V
Battery*	
ZC82V4NA	82V
ZC82V4EUAU	82V

*NA is North America and EUAU is European and Australia



Gauges

Minimize the risk of overloading and ensure long, dependable service from your equipment.

Page: 147



High-Pressure Hoses

Enerpac offers a complete line of high-quality hydraulic hoses. To ensure the integrity of your system, specify only genuine Enerpac hydraulic hoses.

Page: 148



◀ Special Enerpac ZC3-Series pump used for rail stressing applications.

Cordless Hydraulic Pumps



ZC-Series Cordless Hydraulic Pump

The Enerpac ZC-Series pump combines the performance of an electric pump with the convenience and portability of a battery pump. This quiet, cordless solution is ideal for applications where emission and noise are a concern, or when electricity or air is not readily available.

Power for the pump is supplied by a rechargeable 82V Lithium-ion battery. The Lithium-ion battery is capable of providing impressive run times, even under extreme job site conditions.

Valve Options

- 4-way/3-position manual control valve used with double-acting cylinders
- 3-way/3-position manual control valve used with single-acting cylinders
- 4-way/3-position manual control valve with locking and power seat functions used in post tensioning concrete applications

Applications

- High-flow cordless solution for industrial applications
- Foundation repair
- Rail industry
- Post-tensioning concrete

ZC Series



Oil Capacity:

1.75 gallon

Flow at Rated Pressure:

32 in³/min.

Motor Size:

1.36 hp

Maximum Operating Pressure:

10,000 psi

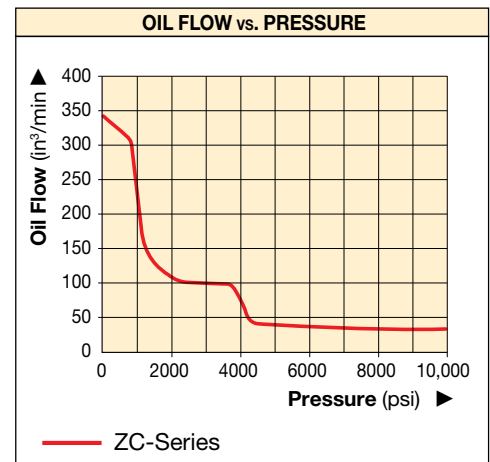
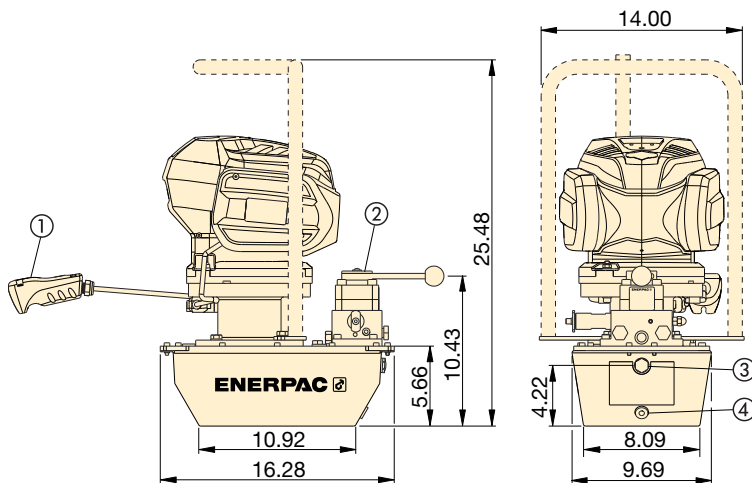

- ① Motor On/Off Remote Pendant
- ② VM43-LPS Valve Shown
- ③ Sight Glass
- ④ Oil Drain 1/2" NPTF

Used with	Oil Capacity (gal)	Manual Valve Model Number	Valve Function	Model Number*	Output Flow Rate (in ³ /min)			Charger Voltage (VAC)	Weight with Oil** (lbs)
					@ no load	@ 4000 psi	@ 10,000 psi		
Single-Acting Cylinder	1.75	VM33	Advance/Neutral/Retract	ZC3308JB	310	80	32	115	65.5
				ZC3308JE				230	
Double-Acting Cylinder	1.75	VM43	Advance/Neutral/Retract	ZC3408JB	310	80	32	115	65.5
				ZC3408JE				230	
Power Seater Post-Tensioning Tools	1.75	VM43LPS	Advance/Hold/Retract	ZC3908JB	310	80	32	115	73.4
				ZC3908JE				230	

* All models meet CE safety requirements and all TUV requirements. Pump includes one charger and battery.

** Weight including oil and battery. Battery weight = 5.7 lbs.

▼ Shown: PUJ1200B



Heavy on Performance, Light on Weight

- Lightweight and compact design
- Large easy-carry handle for maximum portability
- Two-speed operation reduces cycle times for improved productivity
- 115 VAC 50/60-cycle universal motor will operate on voltages as low as 60 volts
- 24 VAC remote motor control, 10-ft length for operator safety
- Starts under full load
- High-strength molded shroud with integral handle, protects motor from contamination and damage
- Designed for intermittent duty cycle

▼ An Economy Pump, PUJ1200B, is used with an RCS302 to reposition a Scissor lift to simplify maintenance.



Hoses

Enerpac offers a complete line of high-quality hydraulic hoses. To ensure the integrity of your system, specify only Enerpac hydraulic hoses.

Page: 148



Gauges

Minimize the risk of overloading and ensure long, dependable service from your equipment. For use with the Economy pump, the **G2535L** gauge and **GA3** gauge adaptor are suggested.

For a full range of gauges, please refer to the System Components section.

Page: 147



Speed Chart

To determine how the 0.5 hp Economy pump will operate your cylinder, see the Pump/Cylinder Speed Chart in the "Yellow Pages".

Page: 409

Used with Cylinder	Oil Capacity (gal)	Model Number *	Pressure Rating	
			(psi)	
			1 st stage	2 nd stage
Single-acting	0.50	PUD1100B	200	10,000
	1.00	PUD1101B	200	10,000
	0.50	PUD1300B	200	10,000
	1.00	PUD1301B	200	10,000
	0.50	PUJ1200B	200	10,000
	1.00	PUJ1201B	200	10,000
Double-acting	0.50	PUJ1400B	200	10,000
	1.00	PUJ1401B	200	10,000



About the Economy Pump

The Economy pump is best suited to power small to medium size cylinders or hydraulic tools. Its lightweight and compact design makes it ideal for applications which require easy transport of the pump.

The Universal motor works well on long extension cords or generator-driven electrical power supplies.

For further application assistance refer to the "Yellow Pages".

PUD1100-Series

- Provides advance/auto-retract of single-acting cylinders
- Ideal for punching applications

- For applications not requiring load holding
- 10-ft pendant controls motor and valve operation

PUD1300-Series

- Provides advance/hold/retract of single-acting cylinders
- 10-foot pendant controls motor and valve operation
- Ideal for applications requiring remote valve operation.

PUJ-Series

- Available with 3- and 4-way valves for single- or double-acting cylinders
- 10-ft cord controls the motor operation
- Manual valves provide advance/retract tool control



* NOTE: CE conformity marking only applies to pumps with an "E" suffix.

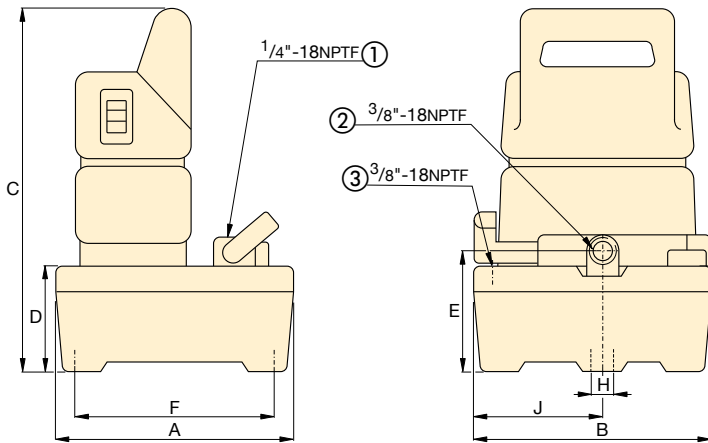

- ① Gauge Port (PUJ1200/1201 only)
- ② Outlet Port
- ③ Tank Port

PU Series



Reservoir Capacity:
0.5 - 1.0 gallon

Flow at Rated Pressure:
20 in³/min.

Motor Size:
0.5 hp

Maximum Operating Pressure:
10,000 psi

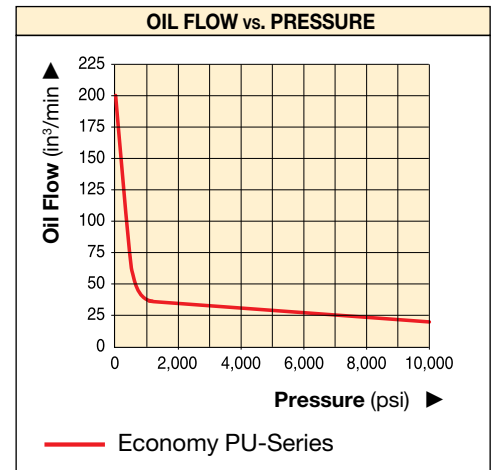

Output Flow Rate (in ³ /min)	Valve Type	Current Draw (Amps)	Motor Voltage (VAC)	Sound Level (dBA)	Dimensions (in)								Weight (lbs)	Model Number*
					1 st stage	2 nd stage	A	B	C	D	E	F		
200	Dump **	9.5	115	85	9.62	9.62	14.25	4.00	4.72	8.00	0.40	5.25	26	PUD1100B
200		9.5	115	85	14.50	12.18	14.72	4.15	5.12	12.74	0.40	5.62	35	PUD1101B
200	Dump and Hold	9.5	115	85	9.62	9.62	14.25	4.00	4.72	8.00	0.40	5.25	26	PUD1300B
200		9.5	115	85	14.50	12.18	14.72	4.15	5.12	12.74	0.40	5.62	35	PUD1301B
200	3-way, 2-pos.	9.5	115	85	9.62	9.62	14.25	4.00	4.72	8.00	0.40	5.25	24	PUJ1200B
200		9.5	115	85	14.50	12.18	14.72	4.15	5.12	12.74	0.40	5.62	31	PUJ1201B
200	4-way, 3-pos.	9.5	115	85	9.62	9.62	14.25	4.00	4.72	8.00	0.40	5.25	29	PUJ1400B
200		9.5	115	85	14.50	12.18	14.72	4.15	5.12	12.74	0.40	5.62	36	PUJ1401B

* For 230 volt applications replace "B" suffix with "E". (CE conformity marking only applies to pumps with an "E" suffix.)
 ** Electric dump valve for auto-retract of cylinders.

▼ Shown: EP3404JE-G



The Heart of the System

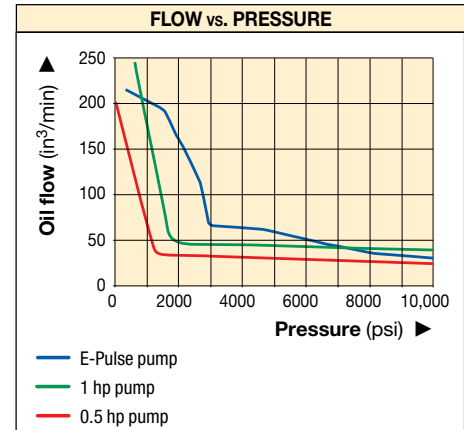

Performance

- Smart controls enable motor to maintain constant power across the pressure range
- Speed control with dial adjustment for precise operation *
- 24V DC power regulator minimizes effects of poor power supply
- Six-piston block design provides even flow for smooth operation of tool

Durability

- High-efficiency permanent magnet, direct drive motor enables continuous use and long service life
- System components enclosed for protection
- Built-in thermal protection
- IP Rating: 54 on the Pump, 67 on the Pendant

Convenience

- Pendant and cord management system
- Draining oil not required for pump element maintenance
- Convenient oil fill port, oil level indicator, and automatic breather



Four Valve Options

- 3/2 manual
- 4/3 manual
- 3/2 dump
- 3/2 dump and hold



Typical E-Pulse Pump Applications

- Lifting
- Spreading
- Cutting
- Pulling
- Crimping
- Pressing
- Bending
- Punching

E-Pulse® Electric Hydraulic Pumps



E-Pulse® Pumps

The Enerpac E-Pulse drives high productivity through its innovative design.

Smart controls enable the motor to maintain constant power providing higher flow than "traditional" ½ hp pumps. Adjustable speed control enables precision as required*.

E-Pulse is designed for convenience. Features include a cord management system and integrated pendant control with a magnet that fits securely into the handle of the pump. The durable aluminum housing is designed to give easy access for serviceability. E-Pulse is the heart to any hydraulic system, ensuring high performance and providing ultimate convenience.

E Series



Useable Reservoir Capacity:

0.8 gallon

Flow at Rated Pressure:

32 in³/min.

Motor Size:

0.85 hp

Maximum Operating Pressure:

10,000 psi



Jog operation
Latch operation

3/2 Jog, 3/2 Dump, 4/3 Jog
10-ft. cord



Jog operation
Dump system pressure

3/2 Dump and Hold
10-ft. cord

Interactive Pendant

- Operation, programming and diagnostics status provided to operator with yellow, green, and red LED as well as vibration pulses
- Fault codes warn operators of any issues related to voltage, temperature, button controls, or if professional service is required

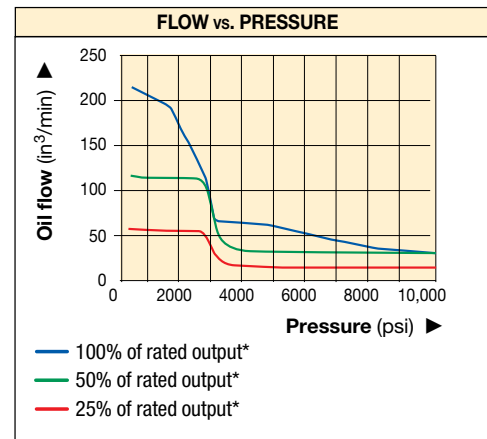
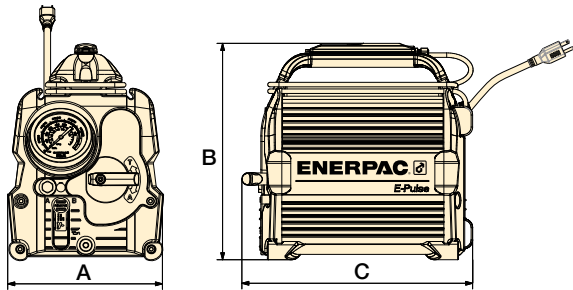

* Flow at alternate speed settings

Used With	Useable Oil Capacity (gal)	Model Number	Output Flow Rate (in ³ /min)				Valve Type	Plug Type	Motor Voltage (VAC)	Current Draw (Amps)	Sound Level (dBA)	Dimensions (in)			Wt. (lbs)
			14.5 psi	2538 psi	5075 psi	10,000 psi						A	B	C	
S/A ¹⁾	0.8	EP3104DB-G	220	130	58	32	Dump	NEMA 5-15	100-120	12	70-85	10.2	14.2	14.0	40.9
	0.8	EP3104DI-G	220	130	58	32		NEMA 6-15	200-250	7	70-85	10.2	14.2	14.0	40.9
	0.8	EP3104DE-G	220	130	58	32		Schuko CEE 7/7	200-250	7	70-85	10.2	14.2	14.0	40.9
	0.8	EP3204JB-G*	220	130	58	32	3-way, 2-pos.	NEMA 5-15	100-120	12	70-85	10.2	14.2	15.2	40.5
	0.8	EP3204JI-G*	220	130	58	32		NEMA 6-15	200-250	7	70-85	10.2	14.2	15.2	40.5
	0.8	EP3204JE-G*	220	130	58	32		Schuko CEE 7/7	200-250	7	70-85	10.2	14.2	15.2	40.5
	0.8	EP3304SB-G*	220	130	58	32	Dump & Hold	NEMA 5-15	100-120	12	70-85	10.2	14.2	14.0	41.2
	0.8	EP3304SI-G*	220	130	58	32		NEMA 6-15	200-250	7	70-85	10.2	14.2	14.0	41.2
	0.8	EP3304SE-G*	220	130	58	32		Schuko CEE 7/7	200-250	7	70-85	10.2	14.2	14.0	41.2
D/A ²⁾	0.8	EP3404JB-G*	220	130	58	32	4-way, 3-pos.	NEMA 5-15	100-120	12	70-85	10.2	14.2	15.2	41.1
	0.8	EP3404JI-G*	220	130	58	32		NEMA 6-15	200-250	7	70-85	10.2	14.2	15.2	41.1
	0.8	EP3404JE-G*	220	130	58	32		Schuko CEE 7/7	200-250	7	70-85	10.2	14.2	15.2	41.1

¹⁾ S/A = Single-acting cylinder

* Adjustable speed control only applies to EP3204, EP3304 and EP3404 pump models.

²⁾ D/A = Double-acting cylinder

Z-Class hydraulic pumps from Enerpac – pumps that run cooler, use less electricity and are easy to service.

Enerpac has used the latest metallurgical, bearing and seal technologies to produce a pump whose features and benefits far surpass the electric pumps that are available today. By reducing the number of moving parts, improving flow dynamics and decreasing friction, Z-Class pumps will stay on the job longer, require less energy to operate and when needed, have lower service costs.



Z-Class electric pumps from Enerpac – simply the best pump you will ever use.



Z Tough.
Dependable.
Innovative.
ZCLASS

Z-Class Pumping Element — The Heart of Your Hydraulic System

Highly efficient design provides increased flow rates, reduced heat generation and a decrease in power consumption. This means improved tool speed and increased service life — which results in higher productivity and lower operating costs.

Heavy-duty bearings extend pump life by reducing friction, reducing surface-loading and lowering bearing stresses.

Pump cavity oil bath extends pump life by reducing heat, improving lubrication and reducing wear.

Self-priming, high-flow 1st stage pump increases pump performance by super-charging the 2nd stage piston pump — improving oil flow in both hot and cold weather operation.

Balanced rotating components reduce vibration creating a smoother running pump — reducing wear, friction and sound levels.

Replaceable piston check-valves increase service life of major pump components.

Ergonomic low-voltage pendant features sealed switches and operates at 24 VDC for improved operator safety.

Back-lit LCD on Pro Z-Class pumps

- pump usage information, hour and cycle counts
- low-voltage warning and recording
- offers self-test and diagnostic capabilities
- information displayed in six languages
- pressure read-out (when used with pressure transducer)
- adjustable pressure setting (when used with pressure transducer)



Back-lit LCD available on ZU and ZE-Series Electric Pumps ▶

Z-Class accessories

Extensive list of accessories including heat exchanger, roll-bar, skid bar, pressure transducer, return-line filter and level and temperature switches, allow complete pump control over a wide range of industrial applications.

Z-Class electric pumps for your application

Available in one flow range for universal motor and four flow ranges for induction motor.



ZU4 Series Pump Applications

- **Mobile:** when frequent pump transport is required and/or on remote locations
- **Universal motor:** 1-phase, runs well under poor voltage supply, using generator power supply or using long extension cord
- **Duty-cycle:** for intermittent applications
- **Cylinders and tools:** for medium to large size single and double-acting applications and high speed



ZE Series Pump Applications

- **Stationary:** when pump remains in one location
- **Induction motor:** 1 and 3-phase for high-cycle usage
- **Duty-cycle:** for heavy-duty, extended cycle application
- **Cylinders and tools:** for medium to large size single- and double-acting applications and high speed

Oil Flow Rate @ 10,000 psi (in ³ /min)	Z-Class Pump Series*	Electric Motor Size (hp)	Air Motor Consumption (scfm)	Gasoline Engine Size** (ft.lbs)	Page:
32	ZC3*	1.4	—	—	98
40	ZE3	1.0	—	—	112
60	ZE4(T)	1.5	—	—	112, 302
60	ZU4(T)	1.7	—	—	106, 300
80	ZA4(T)	—	100	—	126, 306
100	ZG5**	—	—	**	128
120	ZE5(T)	3.0	—	—	112, 302
200	ZE6	7.5	—	—	112
200	ZG6	—	—	17	130

* ZC3 battery powered cordless pumps. ZU4T, ZE4T, ZE5T and ZA4T-Series are Torque Wrench Pumps.

** ZG5 is available in two 4-cycle engine sizes: 7.1 Ft.lbs Honda and 8.5 Ft.lbs Briggs & Stratton.

▼ Shown from left to right: ZU4304MB, ZU4420SBH



ZU Series

Reservoir Capacity:

1.2 - 10.3 gallon

Flow at Rated Pressure:

60 in³/min.

Motor Size:

1.7 hp

Maximum Operating Pressure:

10,000 psi

- Features **Z-Class** high-efficiency two-stage pump design; higher oil flow and bypass pressure, cooler running and requires 18% less current draw than comparable pumps
- Powerful 1.7 hp universal electric motor provides high power-to-weight ratio and excellent low-voltage operating characteristics
- High-strength, molded composite shroud protects motor and electronics, while providing an ergonomic, non-conductive handle for easy transport
- Low-voltage pendant provides additional safety for the operator (remote control units)

Pro-Series pumps only

- LCD readout provides pressure and a number of diagnostic and readout capabilities on a portable electric pump
 - pump usage information, hour and cycle counts
 - self-test, diagnostic and read-out capabilities
 - pressure readout and auto-mode pressure settings



Assisted Return Pumps with Venturi Valve Technology

To improve productivity and plunger retraction, Enerpac offers valve configurations

designed to accelerate your cylinder retraction speeds, ZU4-Series pumps feature Venturi Valve Technology to facilitate the faster return of single-acting gravity return cylinders.

See details in the "Directional Control Valve" section.

Page: 141



Speed Chart

To determine how a "Z" pump will operate your cylinder, see the Pump/Cylinder Speed Chart in the "Yellow Pages".

Page: 409



◀ Designed to be tough, the ZU4-Series with steel reservoirs will take the abuse of today's construction sites.

ZU-Series Specifications and Dimensions

ZU4 Performance							
Motor Size (hp)	Output Flow Rate (in ³ /min)				Motor Electrical Specification (volts-ph-Hz)	Sound Level (dBA)	Relief Valve Adjustment Range (psi)
	100 psi	700 psi	5000 psi	10,000 psi			
1.7	700	535	76	60	115-1-50/60 230-1-50/60	85-90	2,000-10,000

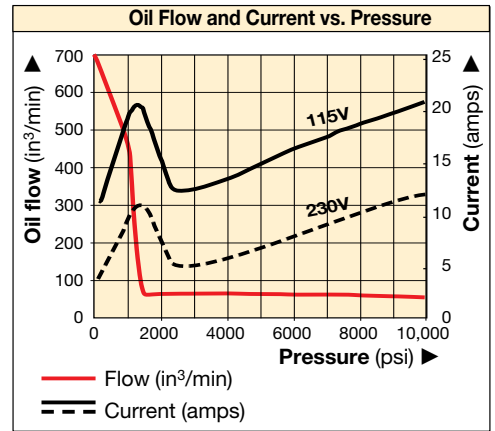

ZU4 Series with 1.2 and 1.8 gallon reservoirs

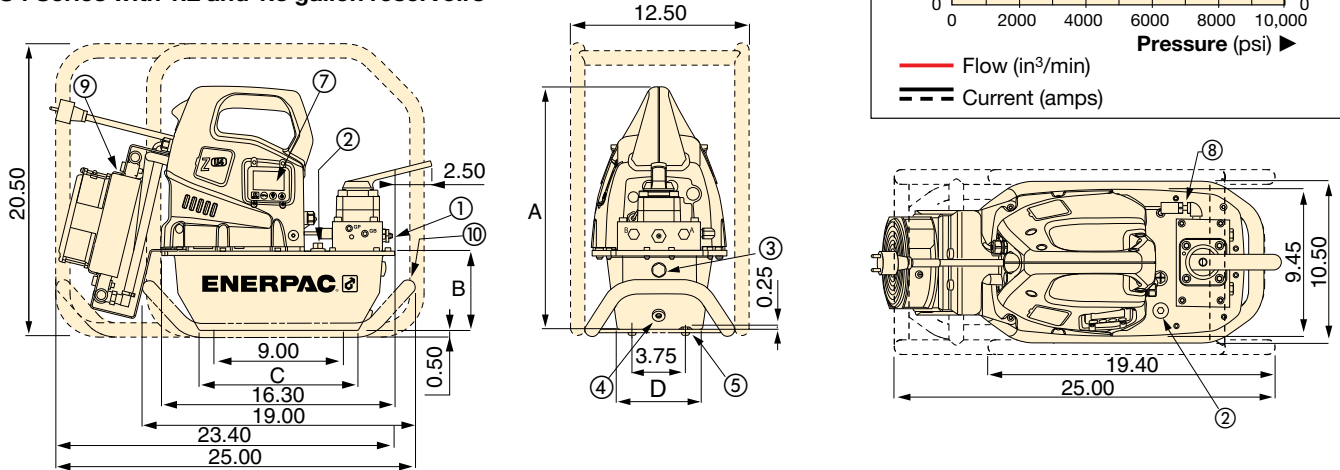

ZU-4 Series with 5.2 and 10.3 gallon reservoirs (Left view shown without side handle)

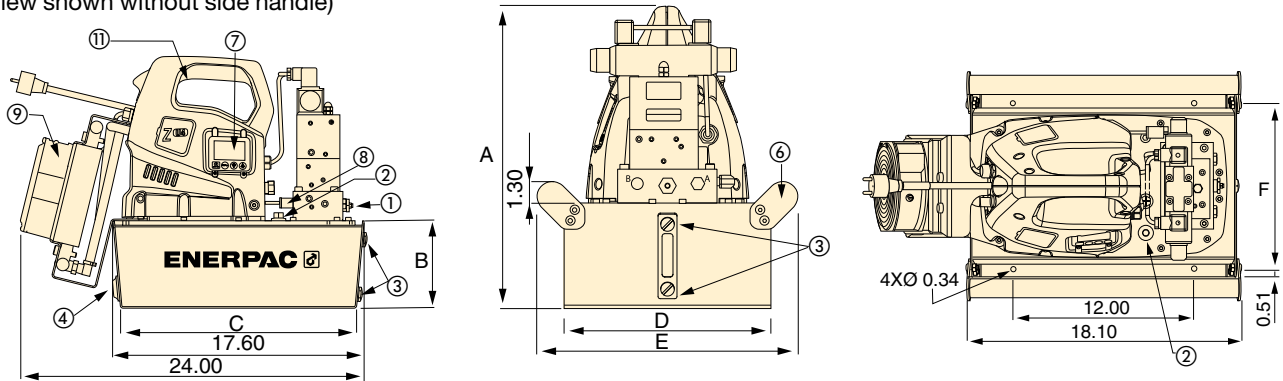

- ① User adjustable relief valve
- ② Oil fill port, SAE#10
- ③ Oil level sight gauge
- ④ Oil Drain, 1/2" NPTF
- ⑤ M8 x 1.25
- ⑥ Handles on all 5.2 and 10.3 gallon reservoirs
- ⑦ Back-lit LCD Electric
- ⑧ Pressure transducer
- ⑨ Heat exchanger
- ⑩ Skid bar
- ⑪ Handle guard installed on all 5.2 and 10.3 gallon reservoirs
- ⑫ Reservoir handles (not shown) included on all 5.2 and 10.3 gallon pumps



◀ Increased output flow and extended brush life increase productivity for post-tensioning applications.

Reservoir Capacity (gal)	Pump Dimensions (in)					
	A	B	C	D	E	F
1.2	16.7	5.6	11.0	6.0	-	-
1.8	16.7	5.6	11.0	8.1	-	-
5.2	18.3	7.1	16.5	16.6	19.7	15.6
10.3	21.7	10.6	15.7	19.9	22.7	18.9

▼ STEP 1: Select a pump from the Pump Ordering Matrix.

The functionality of the pump can be determined by the model number. Utilize the guide below to select the best pump for the application from the pump matrix.

Z	U	4	4	08	J	B	-	H	R
1	2	3	4	5	6	7		8	
Product Type	Motor Type	Flow Group	Valve Type	Reservoir Size	Valve Operation	Voltage		Factory Installed Accessories	

1 Product Type

Z = Pump Series

2 Motor Type

U = Universal electric motor

3 Flow Group

4 = 60 in³/min @ 10,000 psi

4 Valve Type

- 1** = Dump (VE32D)
- 2** = 3 way/2 position manual or electric (VM32 or VE32)
- 3** = 3 way/3 position manual or electric (VM33 or VE33)
- 4** = 4 way/3 position manual or electric (VM43 or VE43)
- 6** = 3 way/3 position locking manual w/po check (VM33L)
- 7** = 3 way/2 position manual (VM22)
- 8** = 4 way/3 position locking manual w/po check (VM43L)
- 9** = 4 way/3 position manual w/power seating (VM43LPS)
- 10** = 3 way/3 position manual, Venturi-Valve (VM33VAC)
- 11** = 3 way/3 position electric, Venturi-Valve (VE33VAC)

5 Reservoir Capacity

- 04** = 1.2 gallon
- 08** = 1.8 gallon
- 20** = 5.2 gallon (includes side handles)
- 40** = 10.3 gallon (includes side handles)

6 Valve Operation

- D** = Dump solenoid valve with pendant and LCD Electric
- J** = Jog manual valve with pendant (w/o LCD)
- L** = Manual valve w/LCD Electric (w/o pendant)
- M** = Manual valve (without pendant and LCD)
- P** = Manual valve with pendant (w/o LCD)
- S** = Solenoid valve with pendant and LCD Electric

7 Voltage

- B** = 115V, 1 ph, 50/60Hz
- E** = 208-240V, 1 ph, 50/60 Hz (w/European plug and CE EMC compliant)
- I** = 208-240V, 1 ph, 50/60 Hz (w/NEMA 6-15 plug)

▼ STEP 2 Factory Installed Accessories

Select factory installed accessories and add to the pump model number after the hyphen. The example above shows that a **Roll Cage (R)** and **Heat Exchanger (H)** have been added to the pump.

8 Factory installed accessories include the following:

- | | |
|---|--------------------------------|
| F = Return Line Filter | R = Roll cage |
| G = Pressure Gauge ¹⁾ | K = Skid Bar |
| H = Heat Exchanger | T = Pressure Transducer |
| L = Level/Temperature Switch ²⁾ | U = Foot Switch |
| N = Lifting Eyes (no reservoir handles) | |

¹⁾⁺²⁾: See the notes about Pressure Gauge and Level/Temperature Switch in right column.

ZU Series



Reservoir Capacity:

1.2 - 10.3 gallon

Flow at Rated Pressure:

60 in³/min.

Motor Size:

1.7 hp

Maximum Operating Pressure:

10,000 psi



Z-Class – A Pump For Every Application

Patented Z-Class pump technology provides high

by-pass pressures for increased productivity—important in applications using long hose runs and high pressure-drop circuits, like heavy lifting or certain double-acting tools.

Enerpac ZU4 Hydraulic Pumps are built to power small to large-sized cylinders or hydraulic tools, or wherever high-speed, intermittent duty, remote hydraulic power is needed.

Pro Electric Pump

Digital (LCD) display features a built-in hour meter and shows self-diagnostic, cycle-count and low voltage warning information.

Pressure can also be displayed when the pump is equipped with a pressure transducer.











Pressure Gauge, Level/Temperature Switch

¹⁾ Pressure Gauge (**G**) not available on pump models with pressure transducer (**T**). The pressure transducer provides digital pressure read-out on LCD-display.



²⁾ Level/Temperature Switch (**L**) requires electric package. Not available on reservoirs 04 and 08.

ZU-Series Pump Ordering Matrix

▼ ZU-SERIES MANUAL PUMP MODELS

	S/A or D/A ¹⁾	Hold 	Valve Type ²⁾	Reservoir Capacity (gal)	Unit Weight w/ oil ⁵⁾ (lbs)	Model Number 115 VAC, 1 Phase ³⁾		
						Manual Only	Standard Electric w/ Pendant	Classic Electric w/ Pendant ⁴⁾
<ul style="list-style-type: none"> • Ideal choice for most applications • Manual valve control, for single-acting or double-acting applications • Motor control on shroud • Venturi Valve technology (VM33VAC) for faster retract of single acting cylinders • Pendant models ideal for light production and lifting applications • Locking valves provide hydraulic locking of cylinder until valve is shifted into retract position 	S/A		VM22	1.2	59	ZU4704MB (I, E)		ZU4704PB (I, E)
	S/A		VM22	1.8	65	ZU4708MB (I, E)		ZU4708PB (I, E)
	S/A		VM22	5.2	108	ZU4720MB (I, E)		ZU4720PB (I, E)
	S/A		VM32	1.2	55	ZU4204MB (I, E)	ZU4204JB (I, E)	
	S/A		VM32	1.8	61	ZU4208MB (I, E)	ZU4208JB (I, E)	
	S/A		VM32	5.2	104	ZU4220MB (I, E)	ZU4220JB (I, E)	
	S/A		VM32	10.3	155	ZU4240MB (I, E)	ZU4240JB (I, E)	
	S/A	●	VM33	1.2	56	ZU4304MB (I, E)		
	S/A	●	VM33	1.8	62	ZU4308MB (I, E)	ZU4308JB (I, E)	ZU4308PB (E)
	S/A	●	VM33	5.2	106	ZU4320MB (I, E)	ZU4320JB (I, E)	ZU4320PB (E)
	S/A	●	VM33	10.3	156	ZU4340MB (I, E)	ZU4340JB (I, E)	ZU4340PB (E)
	S/A	●	VM33VAC	1.8	63	ZU41008MB (E)	ZU41008JB (E)	
	S/A	●	VM33VAC	5.2	106	ZU41020MB (E)	ZU41020JB (E)	
	S/A	●	VM33L	1.8	66	ZU4608MB (E)	ZU4608JB, (E)	
	S/A	●	VM33L	5.2	109	ZU4620MB (E)	ZU4620JB, (E)	
	D/A	●	VM43	1.8	63	ZU4408MB (I, E)	ZU4408JB (I, E)	ZU4408PB (E)
	D/A	●	VM43	5.2	106	ZU4420MB (I, E)	ZU4420JB (I, E)	ZU4420PB (E)
	D/A	●	VM43	10.3	156	ZU4440MB (I, E)	ZU4440JB (I, E)	ZU4440PB (E)
	D/A	●	VM43L	1.8	67	ZU4808MB (E)	ZU4808JB (E)	
D/A	●	VM43L	5.2	110	ZU4820MB (E)	ZU4820JB (E)		

▼ ZU-SERIES PRO SOLENOID VALVE MODELS WITH PENDANT AND LCD ELECTRIC

	S/A or D/A ¹⁾	Neutral 	Valve Type ²⁾	Reservoir Capacity (gal)	Unit Weight w/ oil (lbs)	Model Number 115 VAC, 1 Phase ³⁾
<ul style="list-style-type: none"> • Ideal for punching, crimping and cutting • For use when load-holding is not required 	S/A		VE32D	1.8	69	ZU4108DB (I, E)
	S/A		VE32D	5.2	112	ZU4120DB (I, E)
SINGLE AND DOUBLE ACTING MODELS	S/A	●	VE32	1.2	63	ZU4204SB (I, E)
<ul style="list-style-type: none"> • Ideal for lifting applications and where remote control is required • Motor runs continuously on pumps with VE33 and VE43 valves. • With VE32 valve, motor only runs during the advance function, while holding and retracting, the motor is off • Venturi Valve technology (VE33VAC) for faster retract of single-acting cylinders 	S/A	●	VE32	1.8	69	ZU4208SB (I, E)
	S/A	●	VE32	5.2	112	ZU4220SB (I, E)
	S/A	●	VE33	1.8	81	ZU4308SB (I, E)
	S/A	●	VE33	5.2	124	ZU4320SB (I, E)
	S/A	●	VE33	10.3	174	ZU4340SB (I, E)
	S/A	●	VE33VAC	1.8	74	ZU41108SB (E)
	S/A	●	VE33VAC	5.2	117	ZU41120SB (E)
	S/A	●	VE33VAC	10.3	168	ZU41140SB (E)
	D/A	●	VE43	1.8	81	ZU4408SB (I, E)
	D/A	●	VE43	5.2	124	ZU4420SB (I, E)
	D/A	●	VE43	10.3	174	ZU4440SB (I, E)

¹⁾ S/A or D/A = Single acting or double-acting pumps

²⁾ Additional details can be found in the Directional Control Valve section

³⁾ "I" indicates pump is available in 208-240V, 1-phase, 50/60 Hz with NEMA 6-15 plug. Model number order example: ZU4208MI.

"E" indicates pump is available in 208-240V, 1-phase, 50/60 Hz with European plug and CE CMC compliant. Model number order example: ZU4208ME.

⁴⁾ Classic Electric Pump has traditional electro-mechanical components (transformers, relays, switches) in place of solid-state electronics.

⁵⁾ Manual weights given, Standard Electric w/pendant add 1lb and Classic Electric w/pendant add 3 lbs.

Note: Valve Operation L available on Manual Pumps. Substitute "L" for "M" Valve Operation



Roll Cage (R)

- Protects and stabilizes the pump

Popular Pump Models with Factory Installed Roll Cages	
ZU4108DBR (I, E)	ZU4308MBR (I, E)
ZU4208JBR (I, E)	ZU4320MBR (I, E)
ZU4220JBR (I, E)	ZU4408MBR (I, E)
ZU4208SBR (I, E)	ZU4420MBR (I, E)
ZU4308JBR (I, E)	ZU4408JBR (I, E)
ZU4320JBR (I, E)	ZU4420JBR (I, E)
ZU4308SBR (I, E)	ZU4408SBR (I, E)
ZU4320SBR (I, E)	ZU4420SBR (I, E)

Accessory Kit No.	Fits on Reservoir
	
ZRC-04	1.2 and 1.8 gallon ¹⁾
ZRC-04H	1.2 and 1.8 gallon ²⁾
ZRB-20	5.2 gallon
ZRB-40	10.3 gallon

¹⁾ Without heat exchanger ²⁾ With heat exchanger



Foot Switch (U)

- 10 ft. cord, hands-free control

Popular Pump Models with Factory Installed Foot Switch
ZU4108DBU (I, E)
ZU4208SBU (I, E)
ZU4220SBU (I, E)
ZU4320SBU (I, E)
ZU4408SBU (I, E)
ZU4420SBU (I, E)

Accessory Kit No.	Can be used on ZU4 Pumps with solenoid dump and 3-position valves, LCD electric
	
ZCF-2	Solenoid VE-Series valves

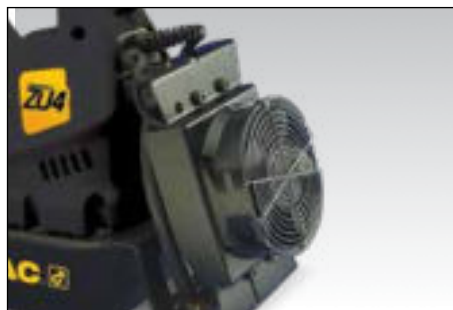

Heat Exchanger (H)

- Removes heat from bypass oil
- Increases oil life, reduces wear on hydraulic components

Popular Pump Models with Factory Installed Heat Exchanger
ZU4108DBH (I, E)
ZU4208SBH (I, E)
ZU4308SBH (I, E)
ZU4408SBH (I, E)
ZU4420SBH (I, E)

Accessory Kit No.	Can be used on
	
ZHE-U115	115V pumps
ZHE-U230	230V pumps



Pressure Transducer (T)

- More durable than analog gauges
- Displays psi, bar or Mpa
- Motor shutoff or shift to neutral at set pressure

Popular Pump Models with Factory Installed Pressure Transducer, Requires LCD Electric Pump
ZU4108DBT (I, E)
ZU4208SBT (I, E)
ZU4308SBT (I, E)
ZU4408SBT (I, E)
ZU4420SBT (I, E)

Accessory Kit No.	Adjustable Pressure Range (psi)	Switch-Point Repeatability	Dead-band (psi)
			
ZPT-U4	50-10,000	± 0.5%	50

Note: The pressure transducer provides digital pressure read-out on LCD-display.

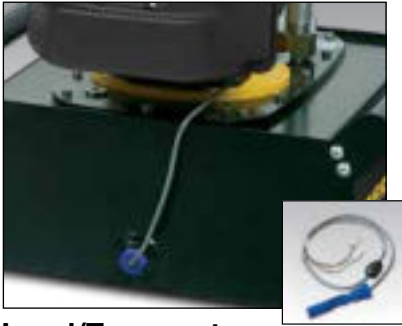

Level/Temperature Switch (L)

- Shuts off pump when high operating temperature or low oil is reached
- Plugs directly into pump electrical enclosure
- Easy installation to pump reservoir
- Requires LCD electric

Model Number	Operating Temperature (° F)	Maximum Pressure (psi)	Wt. (lbs)
ZLS-U4	40-230	150	0.11



Return Line Filter (F)

- 25 micron filter removes contaminants from return oil flow
- Internal by-pass valve prevents damage if filter is dirty
- Features maintenance indicator

Accessory Kit Model Number	Maximum Pressure (psi)	Maximum Oil Flow (GPM)	By-pass Setting (psi)
ZPF	200	12.0	25

ZU Series



Reservoir Capacity:

1.2 - 10.3 gallon

Flow at Rated Pressure:

60 in³/min.

Motor Size:

1.7 hp

Maximum Operating Pressure:

10,000 psi



Heat Exchanger

- Stabilizes oil temperature at a maximum of 130° F at 70° F ambient temperature.

Not suitable for water-glycol or water based fluid.

Thermal Transfer *	Maximum pressure (psi)	Maximum oil flow (GPM)	Voltage (VDC)
Btu/h			
900	300	7.0	12

* At GPM at 70 °F ambient temperature.



Skidbar (K)

- Provides easy two-hand lift
- Provides greater pump stability on soft or uneven surfaces
- Cannot be used in combination with roll cage

Accessory Kit No.	For ZU-Series Pumps with 1.2 and 1.8 Gallon Reservoir	Wt. (lbs)
SBZ-4	1.2-1.8 gal. w/o heat exchanger	4.9
SBZ-4L	1.2-1.8 gal. with heat exchanger	5.5



Pressure Gauge (G)

- Minimize risk of overloading to ensure long life of equipment
- 2.5" face diameter, glycerin filled
- Dual Scale, PSI and Bar

Model No.	Description
G2536L	15,000 psi, Ø 2.5 inches

Note: Pressure Gauge not available on pump models with pressure transducer. The pressure transducer provides digital pressure read-out on LCD-display.

▼ Shown from left to right: ZE3304MBK, ZE4110DBFHR



ZE Series



Reservoir Capacity:

1.2 - 10.3 gallon

Flow at Rated Pressure:

40 - 200 in³/min

Motor Size:

1.0 - 7.5 hp

Maximum Operating Pressure:

10,000 psi

The Standard for Industrial Applications

- Features **Z-Class** high-efficiency pump design; higher oil flow and by-pass pressure, cooler running and requires **18% less current draw** than comparable pumps
- **Totally enclosed, fan-cooled industrial electric motors** supply extended life and stand up to harsh industrial environments
- **Low-voltage pendant, on certain models, provides additional safety for the operator**
- **Multiple valve and reservoir configurations provide application specific models to match the most demanding industrial applications**
- **High-strength, molded electrical enclosure protects electronics, power supplies and LCD readout from harsh industrial environments**
- **LCD readout on electric valve models provides a number of diagnostic and readout capabilities**
- **IP54 Rating for superior dust and water protection**



◀ Rail wheel pulling using RACH aluminum cylinder powered by ZE-Series pump.



Assisted Return Pumps with Venturi Valve Technology

To improve productivity and plunger retraction, Enerpac offers valve configurations

designed to accelerate your cylinder retraction speeds, ZE-Series pumps feature Venturi Valve Technology to facilitate the faster return of single-acting gravity return cylinders. See valve type in ordering matrix and details in the "Directional Control Valve" section.

Page: 141



User Adjustable Relief Valve

All VM and VE-Series have a user adjustable relief valve to allow the operator to easily set the optimum working pressure.



Locking Valves

For applications requiring positive load holding, VM-Series valves (except VM32) are available with a pilot-operated check valve. This provides hydraulic locking of the load until the valve is shifted into the retract position. To order this feature on your ZE-series pump see the valve type in the order matrix.

Page: 140

ZE-Series, Specifications and Dimensions

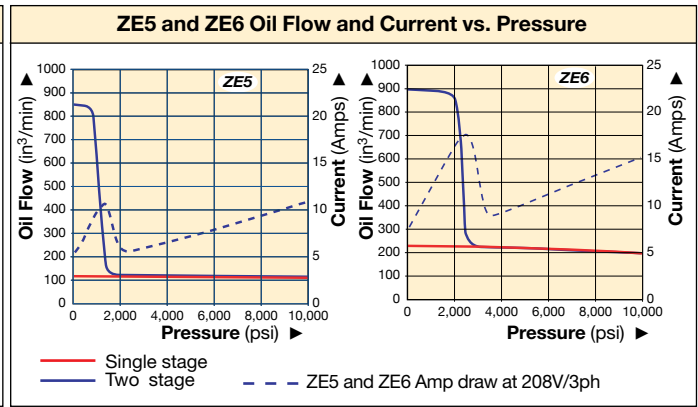
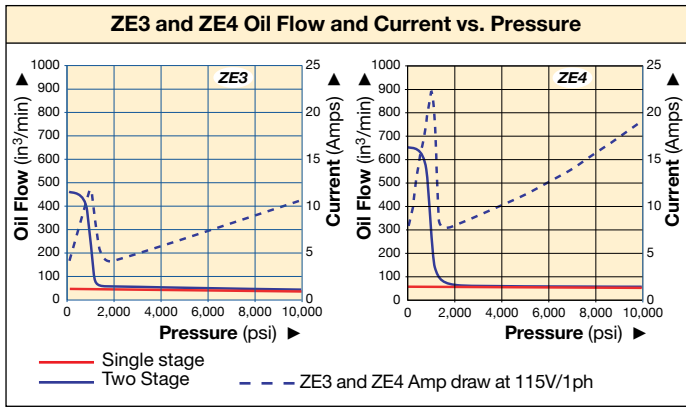

▼ PERFORMANCE CHART

Pump Series	Operation	Output Flow Rate (in ³ /min)				Available Reservoir Sizes (gal)	Motor Size		Relief Valve Adjustment Range (psi)	Sound Level (dBA)
		100 psi	700 psi	5,000 psi	10,000 psi		hp	RPM		
ZE3	Single-stage	43	43	42	40	1.2, 1.8, 2.6, 5.2, 10.3	1.0	1750	1000-10,000	75
	Two-stage	450	385	42	40					
ZE4	Single-stage	64	64	62	60	1.2, 1.8, 2.6, 5.2, 10.3	1.5	1750	1000-10,000	75
	Two-stage	650	600	62	60					
ZE5	Single-stage	128	126	123	120	2.6, 5.2, 10.3	3.0	1750	1000-10,000	75
	Two-stage	850	825	123	120					
ZE6	Single-stage	220	215	210	200	2.6, 5.2, 10.3	7.5	3450	1000-10,000	80
	Two-stage	900	890	210	200					

Output flow rate is listed at 60 Hz. Flow rate will be approximately 5/6 of these values at 50 Hz.

ZE-Series Pumps with 1.2 and 1.8 gallon reservoir

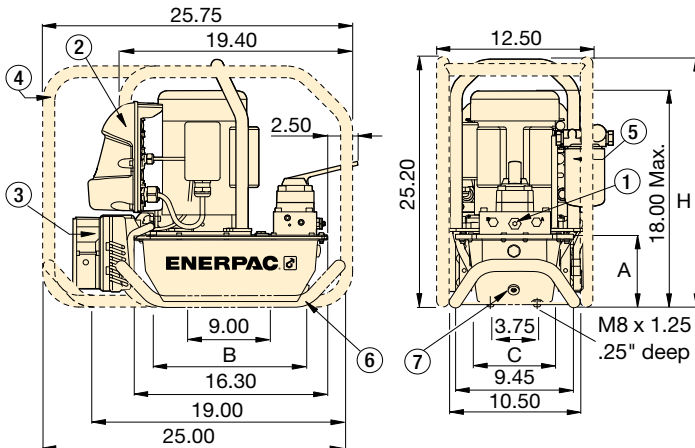

ZE-Series Pumps with 2.6, 5.2, 10.3 gallon reservoir

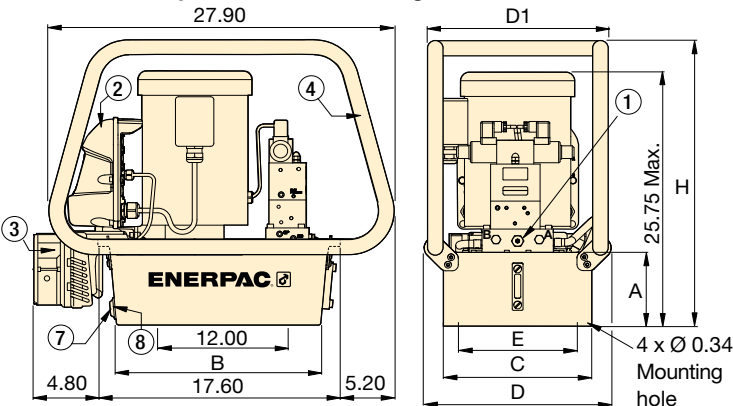

Single-Stage or Two-Stage Pumps

Choose single-stage pumps for applications that require constant flow regardless of pressure, such as testing or clamping.

Two-stage pumps have an increased output flow at low pressure to allow fast movement towards the load, for reduced cycle times and increased productivity.

- ① User-adjustable relief valve on all manual and solenoid valves:
3/8" NPTF on A and B ports
1/4" NPTF on auxiliary ports
- ② Electric Box
- ③ Heat Exchanger
- ④ Roll Bar
- ⑤ Return Line Filter
- ⑥ Skid Bar
- ⑦ Oil Drain
- ⑧ Oil Level/Temperature Switch

Reservoir Capacity (gal)	ZE-Series Pump Dimensions (in)						
	A	B	C	D	D1	E	H
1.2	5.6	11.0	6.0	-	-	-	20.2
1.8	5.6	11.0	8.1	-	-	-	20.2
2.6	6.2	16.5	12.0	15.1	14.6	11.0	23.6
5.2	7.1	16.5	16.6	19.7	19.2	15.6	24.6
10.3	10.6	15.7	19.9	22.7	22.5	18.9	28.1

▼ STEP 1: Select a Pump from the Pump Ordering Matrix.

The functionality of the pump can be determined by the model number. Utilize the guide below to select the best pump for the application from the pump matrix.



1 Product Type

Z = Pump Class

2 Motor Type

E = Induction Electric Motor

3 Flow Group

- 3** = 40 in³/min @ 10,000 psi
- 4** = 60 in³/min @ 10,000 psi
- 5** = 120 in³/min @ 10,000 psi
- 6** = 200 in³/min @ 10,000 psi

4 Valve Types

- 0** = No valve w/cover plate
- 1** = Dump (VE32D)
- 2** = 3-way/2-position manual (VM32)
- 3** = 3-way/3-position manual or electric (VM33 or VE33)
- 4** = 4-way/3-position manual or electric (VM43 or VE43)
- 6** = 3-way/3-position locking manual w/po check (VM33L)
- 7** = 3-way/2-position manual (VM22)
- 8** = 4-way/3-position locking manual w/po check (VM43L)
- 10** = 3-way/3-position manual, Venturi-Valve (VM33VAC)⁶⁾
- 11** = 3-way/3-position electric, Venturi-Valve (VE33VAC)⁶⁾

5 Reservoir Capacity

- 04** = 1.2 gallon *
 - 08** = 1.8 gallon *
 - 10** = 2.6 gallon
 - 20** = 5.2 gallon
 - 40** = 10.3 gallon
- * not available on ZE5 or ZE6

6 Valve Operation

- D** = Dump valve (w/ pendant and LCD)
- L** = Manual valve (w/o pendant, w/ LCD)
- M** = Manual valve³⁾ (w/o pendant or LCD)
- N** = No valve³⁾ (no electrical box)
- S** = Solenoid valve (w/ pendant and LCD)

7 Voltage

Single Phase (not on ZE5 or ZE6)

- B** = 115V 1 ph 50-60Hz¹⁾
- E** = 208-240V 1 ph 50-60 Hz European Plug
- I** = 208-240V 1 ph 50-60 Hz USA Plug

Three Phase³⁾

- G** = 208-240V 3ph 50-60Hz
- J** = 460-480V 3ph 50-60Hz
- W** = 380-415V 3ph 50-60Hz

▼ STEP 2: Factory Installed Accessories

Select factory installed accessories and add to the pump model number after the hyphen. The example above shows that a **Return Line Filter (F)** and **Heat Exchanger (H)** have been added to the pump.

8 Factory installed accessories include the following:

- | | |
|--|---|
| F = Return Line Filter | N = No reservoir handles (includes lifting eyes) ⁷⁾ |
| G = 0-15,000 psi gauge (2 ¹ / ₂ " ⁴⁾ | R = Roll cage |
| H = Heat exchanger ²⁾ | S = Single stage ⁵⁾ |
| K = Skid bar (1.2 and 1.8 gal. reservoirs only) | T = Pressure transducer ^{2) 4)} |
| L = Level/temperature switch ²⁾ | U = Foot switch ²⁾ |

1) 115-volt pumps are supplied with 15-amp plug for intermittent use. 20-amp circuit recommended for frequent full pressure use.
 2) These accessories require LCD electrical package. Pressure switch option only available on manual valves without locking valve. The LCD electrical package can accept either a pressure switch or pressure transducer, but not both.
 3) Standard Electric models with 3-phase motors without electric boxes are shipped without cord, motor starter or overload protection.
 4) Pressure gauge not available on pump models with pressure transducer. Pressure transducer provides digital pressure readout on LCD display.
 5) Not available on Valve Types 10, 11
 6) Not available on ZE3
 7) Lifting eyes (N) not available on reservoir capacities 04 or 08.

▼ ZE-SERIES PUMP MODELS

<p>No Valve with coverplate, no electric box</p>
<p>Manual Valve without electric box or LCD</p> <ul style="list-style-type: none"> • Ideal choice for most applications • Manual valve control, for both single-acting or double-acting applications • Venturi Valve Technology (VM33VAC) for faster retract of single-acting cylinders • Manual motor control • On/off switch on 1-phase electric motor
<p>Solenoid Dump Valve with electric box and LCD</p> <ul style="list-style-type: none"> • Ideal for punching, crimping and cutting • For use when load holding is not required • Push-button control pendant with 10-ft. cord controls the valve and motor
<p>Solenoid 3-position Valve with Electric Box</p> <ul style="list-style-type: none"> • Ideal for production and lifting applications • All valves are 3-position for Advance-Hold-Retract • Venturi Valve Technology (VE33VAC) for faster retract of single-acting cylinders • Push-button control pendant with 10-ft. cord controls the valve and motor

ZE-Series Pump Ordering Matrix

S/A or D/A ¹⁾	Hold 	Valve Type ²⁾	Reservoir Capacity (gal)	ZE3 Series (1.0 hp) Output Flow Rate at 10,000 psi: 40 in ³ /min		ZE4 Series (1.5 hp) Output Flow Rate at 10,000 psi: 60 in ³ /min		ZE5 Series (3.0 hp) Output Flow Rate at 10,000 psi: 120 in ³ /min		ZE6 Series (7.5 hp) Output Flow Rate at 10,000 psi: 200 in ³ /min	
				Model Number ³⁾	Wt. (lbs)	Model Number ³⁾	Wt. (lbs)	Model Number ³⁾	Wt. (lbs)	Model Number ³⁾	Wt. (lbs)
			1.8	ZE3008NB (I, E, W, J, G)	99	ZE4008NB (I, E, W, J, G)	95				
			2.6	ZE3010NB (I, E, W, J, G)	99	ZE4010NB (I, E, W, J, G)	108	ZE5010NW (J, G)	119	ZE6010NW (J, G)	158
			5.2	ZE3020NB (I, E, W, J, G)	126	ZE4020NB (I, E, W, J, G)	135	ZE5020NW (J, G)	146	ZE6020NW (J, G)	185
			10.3	ZE3040NB (I, E, W, J, G)	177	ZE4040NB (I, E, W, J, G)	186	ZE5040NW (J, G)	197	ZE6040NW (J, G)	236
S/A		VM22	5.2			ZE4720MB (E, W)	143				
S/A		VM32	1.2	ZE3204MB (E)	85						
S/A		VM32	1.8	ZE3208MB (I, E, W, J, G)	91	ZE4208MB (I, E, W, J, G)	100				
S/A		VM32	2.6	ZE3210MB (I, E, W, J, G)	104	ZE4210MB (I, E, W, J, G)	113	ZE5210MW (J, G)	124	ZE6210MW (J, G)	163
S/A		VM32	5.2	ZE3220MB (I, E, W, J, G)	131	ZE4220MB (I, E, W, J, G)	140	ZE5220MW (J, G)	151	ZE6220MW (J, G)	190
S/A	●	VM33	1.2	ZE3304MB (E)	86						
S/A	●	VM33	1.8	ZE3308MB (I, E, W, J, G)	92	ZE4308MB (I, E, W, J, G)	101				
S/A	●	VM33	2.6	ZE3310MB (I, E, W, J, G)	105	ZE4310MB (I, E, W, J, G)	114	ZE5310MW (J, G)	125	ZE6310MW (J, G)	164
S/A	●	VM33	5.2	ZE3320MB (I, E, W, J, G)	132	ZE4320MB (I, E, W, J, G)	141	ZE5320MW (J, G)	152	ZE6320MW (J, G)	191
S/A	●	VM33	10.3	ZE3340MB (I, E, W, J, G)	183	ZE4340MB (I, E, W, J, G)	192	ZE5340MW (J, G)	203	ZE6340MW (J, G)	242
S/A	●	VM33VAC	1.8			ZE41008MB (I, E, W, J, G)	101				
S/A	●	VM33VAC	5.2			ZE41020MB (I, E, W, J, G)	141	ZE51020MW (J, G)	153	ZE61020MW (J, G)	192
S/A	●	VM33VAC	10.3					ZE51040MW (J, G)	203	ZE61040MW (J, G)	242
S/A	●	VM33L	1.8	ZE3608MB (I, E, W, J, G)	92						
S/A	●	VM33L	5.2	ZE3620MB (I, E, W, J, G)	136	ZE4620MB (I, E, W, J, G)	145				
S/A	●	VM33L	10.3	ZE3640MB (I, E, W, J, G)	187	ZE4640MB (I, E, W, J, G)	196				
D/A	●	VM43	1.2	ZE3404MB (E)	86						
D/A	●	VM43	1.8	ZE3408MB (I, E, W, J, G)	92	ZE4408MB (I, E, W, J, G)	101				
D/A	●	VM43	2.6	ZE3410MB (I, E, W, J, G)	106	ZE4410MB (I, E, W, J, G)	114	ZE5410MW (J, G)	125	ZE6410MW (J, G)	164
D/A	●	VM43	5.2	ZE3420MB (I, E, W, J, G)	132	ZE4420MB (I, E, W, J, G)	141	ZE5420MW (J, G)	152	ZE6420MW (J, G)	191
D/A	●	VM43	10.3	ZE3440MB (I, E, W, J, G)	183	ZE4440MB (I, E, W, J, G)	192	ZE5440MW (J, G)	203	ZE6440MW (J, G)	242
D/A	●	VM43L	1.8	ZE3808MB (I, E, W, J, G)	96						
D/A	●	VM43L	5.2	ZE3820MB (I, E, W, J, G)	136	ZE4820MB (I, E, W, J, G)	145	ZE5820MW (J, G)	156	ZE6820MW (J, G)	195
D/A	●	VM43L	10.3	ZE3840MB (I, E, W, J, G)	187	ZE4840MB (I, E, W, J, G)	196	ZE5840MW (J, G)	207	ZE6840MW (J, G)	246
S/A		VE32D	1.2	ZE3104DB (I, E, W, J, G)	94						
S/A		VE32D	1.8	ZE3108DB (I, E, W, J, G)	100	ZE4108DB (I, E, W, J, G)	109				
S/A		VE32D	2.6	ZE3110DB (I, E, W, J, G)	114	ZE4110DB (I, E, W, J, G)	122	ZE5110DW (J, G)	136	ZE6110DW (J, G)	175
S/A		VE32D	5.2	ZE3120DB (I, E, W, J, G)	140	ZE4120DB (I, E, W, J, G)	149	ZE5120DW (J, G)	163	ZE6120DW (J, G)	202
S/A		VE32D	10.3			ZE4140DB (I, E, W, J, G)	199	ZE5140DW (J, G)	213	ZE6140DW (J, G)	252
S/A	●	VE33	1.2	ZE3304SB (I, E, W, J, G)	106						
S/A	●	VE33	1.8	ZE3308SB (I, E, W, J, G)	112	ZE4308SB (I, E, W, J, G)	121				
S/A	●	VE33	2.6	ZE3310SB (I, E, W, J, G)	125	ZE4310SB (I, E, W, J, G)	134	ZE5310SW (J, G)	148	ZE6310SW (J, G)	186
S/A	●	VE33	5.2	ZE3320SB (I, E, W, J, G)	152	ZE4320SB (I, E, W, J, G)	161	ZE5320SW (J, G)	174	ZE6320SW (J, G)	213
S/A	●	VE33	10.3	ZE3340SB (I, E, W, J, G)	203	ZE4340SB (I, E, W, J, G)	212	ZE5340SW (J, G)	225	ZE6340SW (J, G)	264
S/A	●	VE33VAC	1.8			ZE41108SB (I, E, W, J, G)	115				
S/A	●	VE33VAC	5.2			ZE41120SB (I, E, W, J, G)	155	ZE51120SW (J, G)	168	ZE61120SW (J, G)	207
S/A	●	VE33VAC	10.3					ZE51140SW (J, G)	219	ZE61140SW (J, G)	258
D/A	●	VE43	1.2	ZE3404SB (I, E, W, J, G)	106						
D/A	●	VE43	1.8	ZE3408SB (I, E, W, J, G)	112	ZE4408SB (I, E, W, J, G)	121				
D/A	●	VE43	2.6	ZE3410SB (I, E, W, J, G)	125	ZE4410SB (I, E, W, J, G)	134	ZE5410SW (J, G)	148	ZE6410SW (J, G)	186
D/A	●	VE43	5.2	ZE3420SB (I, E, W, J, G)	152	ZE4420SB (I, E, W, J, G)	161	ZE5420SW (J, G)	174	ZE6420SW (J, G)	213
D/A	●	VE43	10.3	ZE3440SB (I, E, W, J, G)	203	ZE4440SB (I, E, W, J, G)	212	ZE5440SW (J, G)	225	ZE6440SW (J, G)	264

1) S/A = Single acting / D/A = Double acting

2) See Valve Section for technical information.

3) "B" suffix model numbers shown are 115 VAC, 1-phase, 50/60 Hz

Other voltages available as shown. Replace "B" voltage suffix with selected voltage character. Model number order example: ZE4108DI is 208-240V, 1 phase, 50/60 Hz.

See Ordering Guide page for voltage descriptions

Note: Voltage options K (440V, 3-phase, 50/60Hz) and R (575V, 3-phase, 60 Hz) are available on select models. Contact your local representative for availability.

Note: Valve Operation L available on Manual Pumps. Substitute "L" for "M" Valve Operation



Electric Box ¹⁾

- Back-lit LCD
- Pump usage information, hour and cycle counts
- Low-voltage warning and recording
- Self-test and diagnostic capabilities
- Pressure read-out ²⁾
- Auto-mode pressure setting ²⁾
- Information can be displayed in six languages ³⁾

¹⁾ Included on pumps with solenoid valves
²⁾ When used with pressure transducer
³⁾ English, French, German, Italian, Spanish and Portuguese



Level/Temperature Switch ⁴⁾

- Shuts down pump before oil level reaches an unsafe level, avoiding damage due to cavitation
- Shuts down pump when unsafe oil temperature is reached
- Ideal if pump is used in remote area without visual access to oil level

⁴⁾ 24V, requires Electric Box. Available for 2.6, 5.2 and 10.3 gallon reservoirs

Accessory Kit Model Number	Fixed Temperature Signal (° F)	Operating Temperature (° F)	Max. Pressure (psi)
ZLS-U4	75	40 - 230	150



Return Line Filter

- 25 micron nominal filter removes contaminants from return oil flow before allowing it back into tank
- Internal by-pass valve prevents damage if filter is dirty
- With maintenance indicator
- Replaceable filter element PF25

Accessory Kit Model Number	Maximum Pressure (psi)	Maximum Oil Flow (GPM)	By-pass Setting (psi)
ZPF	200	12.0	25



Roll Cage

- For easy portability
- Protects pump and electric box
- Available for all reservoir sizes

Accessory Kit Number	Fits on Reservoir
ZRC-04	1.2 and 1.8 gallon ¹⁾
ZRC0-4H	1.2 and 1.8 gallon ²⁾
ZRB-10	2.6 gallon
ZRB-20	5.2 gallon
ZRB-40	10.3 gallon

¹⁾ Without heat exchanger
²⁾ With heat exchanger



Skid Bar

- Provides easy two-hand lift
- Provides greater pump stability on soft or uneven surfaces

Accessory Kit Number	For ZE-Series Pumps with Reservoir	Wt. (lbs)
SBZ-4	1.2 & 1.8 gal. w/o heat exchanger	4.9
SBZ-4L	1.2 & 1.8 gal. with heat exchanger	5.5



Foot Switch ⁵⁾

- Hands-free remote control on solenoid dump and 3-position valves
- With 10-foot cord

⁵⁾ 15V, requires Electric Box

Accessory Kit Number	Can be used on ZE-Series Pumps with
ZCF-2	Solenoid VE-Series valves



Pressure Transducer ¹⁾

- Displays pressure on LCD in bar, MPa or psi
- More accurate than analog gauge
- Calibration can be fine-tuned for certification
- Easy-viewing variable rate display
- “Set pressure” feature turns off motor at user defined pressure (or shifts valve to neutral on models with VE33/ VE43 valves)

¹⁾ 24V, requires Electric Box

Accessory Kit Model number	Adjustable Pressure Range (psi)	Switch-point Repeatability	Dead-band (psi)
ZPT-U4	50-10,000	± 0.5%	50



Pressure Switch ^{2) 3) 4)}

- Controls pump, monitors system
- Adjustable pressure 500-10,000 psi
- Includes glycerin filled, 15,000 psi pressure gauge, G2536L
- Accuracy ± 1.5% of full scale

²⁾ 24V, requires Electric Box. Not available in combination with pressure transducer.

³⁾ Not available on LCD electronics

⁴⁾ Only available on locking valves without pressure transducer

Accessory Kit Model number	Switch-point Repeatability	Deadband (psi)	Oil Ports (NPT)
ZPS-E3	± 2%	115-550	3/8"



Heat Exchanger ⁵⁾

- Removes heat from bypass oil to provide cooler operation
- Stabilizes oil viscosity, increasing oil life, and reduces wear of pump and other hydraulic components

⁵⁾ 24V DC, requires electric box

Accessory Kit Model number	Fits on Reservoir	Weight (lbs)
ZHE-E04	1.2 and 1.8 gallon	9.0
ZHE-E10	2.6, 5.2 and 10.3 gallon	9.0



Pressure Gauge (G)

- Minimize risk of overloading to ensure long life of equipment
- 2.5" face diameter, glycerin filled
- Dual Scale, PSI and Bar

Note: Pressure Gauge not available on pump models with pressure transducer. The pressure transducer provides digital pressure read-out on LCD-display.

Model No.	Description
G2536L	15,000 psi, Ø 2.5 inches

ZE Series



Reservoir Capacity:
1.2 - 10.3 gallon

Flow at Rated Pressure:
40 - 200 in³/min

Motor Size:
1.0 - 7.5 hp

Maximum Operating Pressure:
10,000 psi



ZPT-U4 Pressure Transducer

More durable against mechanical and hydraulic shock than analog gauges.

- Digital pressure read-out provides accuracy of 5% of full scale.
- Easy-viewing variable rate display automatically varies increments between 44, 203, 508 and 2103 psi as rate of pressure change increases.
- “Set pressure” feature turns off motor at user defined pressure (or shifts valve to neutral on VE33 and VE43 valves).



ZHE-Series Heat Exchangers

Heat exchanger stabilizes oil temperature at 130° F at 70° F ambient temperature. Thermal transfer at 5 GPM and 70° F ambient temperature: 900 Btu/hour.

Do not exceed maximum oil flow of 7.0 GPM and maximum pressure of 300 psi. Not suitable for water-glycol or high water based fluids.

▼ Shown: PEM8418



The Largest Pump for the Largest Jobs

- Panel-mounted pressure gauge and adjustable relief valve for system pressure control
- Two-speed pump design, with high by-pass pressure, for rapid cylinder advance
- Dual-voltage motor (230/460 VAC, 3-phase, 60 Hz)
- Full length reservoir sight tube with integral thermometer for ease in monitoring oil level and temperature
- Low voltage controls to protect the pump operator



Locking Valves

Pumps with VM4 manual valves are available with VM4L manual valves for positive load holding. Add suffix "L" to pump model number.

Page: 140



FS34 Foot Control Switch

This 3-position switch allows hands-free control of the solenoid valve on the pump. Operates 24V and

115V valves that use the square electrical connector.



Hoses

Enerpac offers a complete line of high-quality hydraulic hoses. To ensure the integrity of your system, specify only genuine Enerpac hydraulic hoses.

Page: 148



◀ With similar specifications, a gasoline-powered EGM8000 Series is shown here performing a synchronized lift.

8000-Series Electric Pumps



About the 8000 Series

The 8000 Series is the largest pump in the Enerpac line and the best choice to power most large size cylinders, multiple cylinder circuits, and applications where the need for high speed requires high flow rates.

The 8000 Series, with its large reservoir capacity, is best suited for large jobs and may be the only solution because of the required oil capacity.

For further application assistance see our "Yellow Pages", or consult your local Enerpac office.

PEM PER Series



Reservoir Capacity:
25 gallon

Flow at Rated Pressure:
2.0 gal/min.

Motor Size:
12.5 hp

Maximum Operating Pressure:
10,000 psi

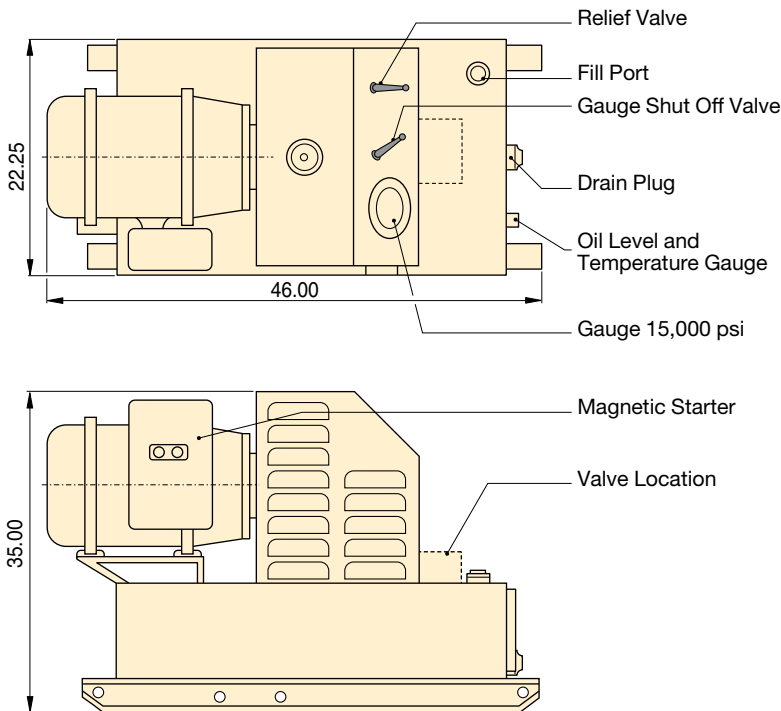

Dimensions shown in inches.



Speed Chart

To determine how an 8000-Series pump will operate your cylinder, see the Pump/Cylinder Speed Chart in the "Yellow Pages".

Page: 409

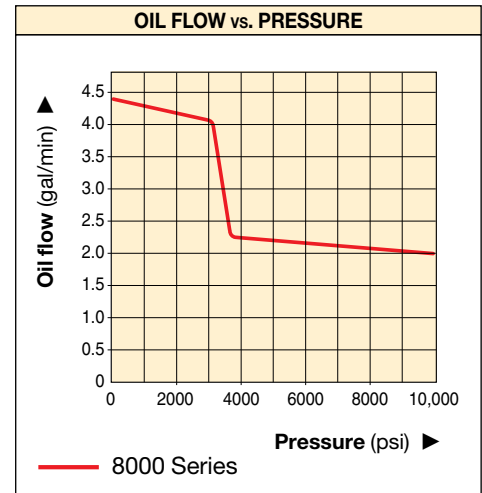

Used with Cylinder	Usable Oil Capacity (gal)	Model Number	Pressure Rating (psi)		Output Flow Rate (gal/min)		Valve Type	Valve Function	Current Draw (Amps)	Motor Voltage* (VAC)	Sound Level (dBA)	Weight (lbs)
			1st stage	2nd stage	1st stage	2nd stage						
Single-acting	18	PEM8218	3,700	10,000	4.4	2.0	Manual (VM-2)	3-way, 2-pos.	33.0	230	78-84	720
	18	PEM8218C	3,700	10,000	4.4	2.0			16.5	460	78-84	720
Double-acting	18	PEM8418	3,700	10,000	4.4	2.0	Manual (VM-4)	4-way, 3-pos.	33.0	230	78-84	720
	18	PEM8418C	3,700	10,000	4.4	2.0			16.5	460	78-84	720
	18	PER8418	3,700	10,000	4.4	2.0	Solenoid (VE43)	4-way, 3-pos.	33.0	230	78-84	765
	18	PER8418C	3,700	10,000	4.4	2.0			16.5	460	78-84	765

* Consult Enerpac for availability of other voltages.

▼ Shown from top to bottom: PA1150, PA133



PA Series

Reservoir Capacity:
36 - 80 in³

Flow at Rated Pressure:
8 in³/min.

Maximum Operating Pressure:
10,000 psi



PC66 Reservoir Conversion Kit

Double the reservoir capacity of your existing PA133 with this easy to install conversion kit.

Model number

PC66

- Rugged construction – built for long life and easy service
- Swivel coupling simplifies hydraulic connection and pump operation
- Three-position treadle provides cylinder advance, hold and retract operation
- PA133 operates in all positions for increased versatility in use and mounting
- Base mounting slots provided on PA133

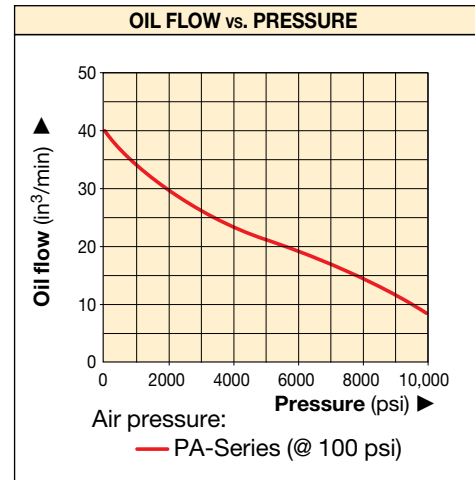

Dimensions shown in inches.

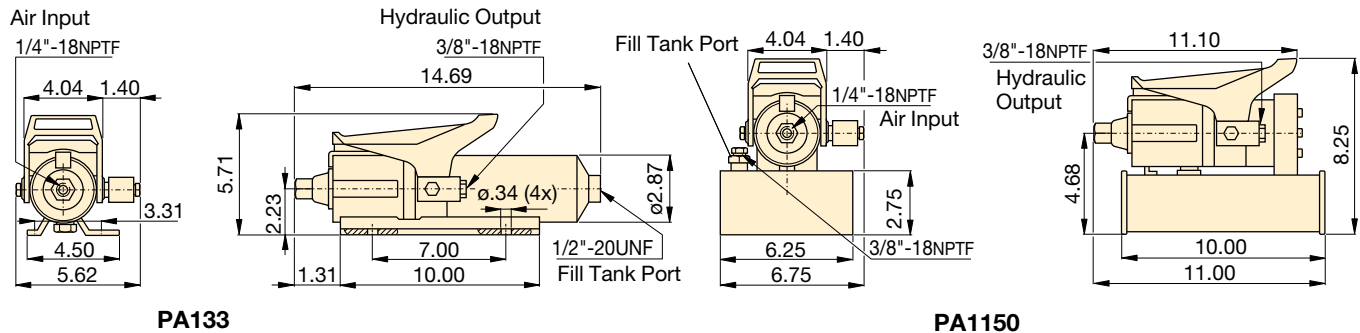

Used with Cylinder	Usable Oil Capacity (in ³)	Model Number	Pressure Rating (psi)	Output Flow Rate (in ³ /min)		Valve Function	Air Pressure Range* (psi)	Air Consumption (scfm)	Sound Level (dBA)	Weight (lbs)
				No load	Load					
Single-acting	36	PA133	10,000	40	8	Advance/Hold/Retract	60-120	9	85	12
	80	PA1150	10,000	40	8	Advance/Hold/Retract	60-120	9	85	18

* Recommended Regulator-Filter-Lubricator: RFL102.

PAM-Series, Air Hydraulic Pumps

▼ Shown: PAM1041



PAM Series

Reservoir Capacity:

1.0 - 2.0 gallon

Flow at Rated Pressure:

9 in³/min.

Maximum Operating Pressure:

10,000 psi



Locking Valves

Pumps with VM4 manual valves are available with VM4L manual locking valves instead. Add suffix "L" to pump model number.

Page: 140



Remote Air Valve

For remote operation of PAM10 series air pumps. Permits either hand or foot operation.

Model number ¹⁾

VA2

- Twin air motor configuration delivers high-flow performance in first stage, up to 200 psi, for rapid cylinder advance
- 1 and 2-gallon reservoirs for use with a wide range of cylinders
- Integral shroud protects air motors and provides easy portability

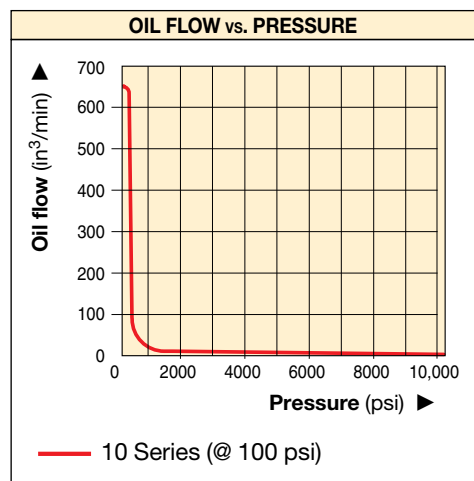
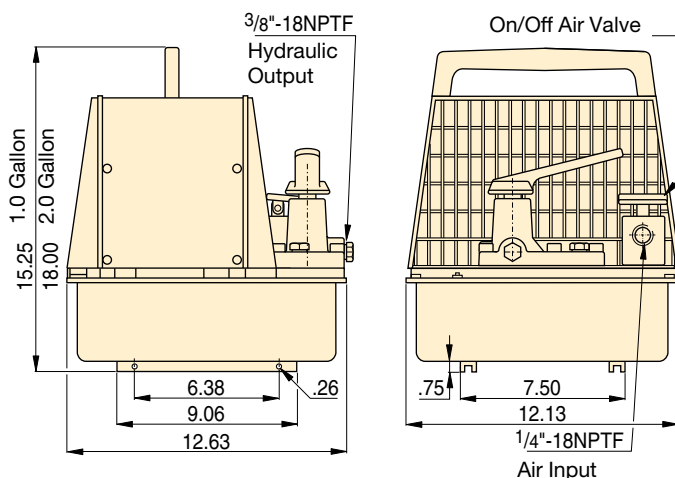

Used with Cylinder	Usable Oil Capacity (gal)	Model Number (with Shroud)	Pressure Rating (psi)	Output Flow Rate (in ³ /min)		Valve Function	Valve Model	Air Pressure Range* (psi)	Air Consumption (scfm)	Sound Level (dBA)	Weight (lbs)
				1 st stage	2 nd stage						
Single-acting	0.7	PAM1021	10,000	650	9	Adv/Hold/Ret	VM2	60-120	18	87	50
	2.0	PAM1022	10,000	650	9	Adv/Hold/Ret	VM2	60-120	18	87	60
Double-acting	0.7	PAM1041	10,000	650	9	Adv/Hold/Ret	VM4	60-120	18	87	50
	2.0	PAM1042	10,000	650	9	Adv/Hold/Ret	VM4	60-120	18	87	60

* Recommended Regulator-Filter-Lubricator: RFL102

▼ Shown left to right: PAMG1402N, PATG1102N, PARG1102N, PATG1105N



Compact Air Over Hydraulic

- High efficiency cast aluminum air motor for increased life and reduced air consumption
- Fully serviceable air motor assembly
- Reinforced heavy-duty reservoir for applications in tough environments
- New generation air-saver piston with rugged one-piece design reduces air consumption and operating costs
- Return-to-tank port for use in remote valve applications
- Quiet – only 76 dBA with low air consumption of 12 scfm
- Operating air pressure: 40-125 psi, enables pump to start at extremely low pressure
- Internal pressure-relief valve provides overload protection
- Mounting Bracket Kit (MTB1) available to mount pumps to horizontal or vertical surfaces



RFL102 Regulator-Filter-Lubricator

Recommended for use with all air pumps. Provides clean, lubricated air and allows

for air pressure adjustment. Steel bowl guards are standard.

Order model number ¹⁾

RFL102



Large Reservoir Models

The Turbo II Air Pump is also available with a larger reservoir: **PATG1105N**, **PAMG1405N**, and **PARG1105N**.



Hoses

Enerpac offers a complete line of high-quality hydraulic hoses. To ensure the integrity of your system, specify only

genuine Enerpac hydraulic hoses.

Page: 148

▼ Easily operated by hand or by foot.



Used with Cylinder	Usable Oil Capacity (in ³)	Model Number
Single-acting	127	PATG1102N
	230	PATG1105N
	127	PARG1102N
	230	PARG1105N
Double-acting	127	PAMG1402N
	230	PAMG1405N

Turbo II Air Hydraulic Pumps



The PATG-models use a foot or hand-operated treadle to control air and valve functions.

The PAMG-models use a treadle with a locking feature and a 4-way manual valve.

The PARG-models use a 15-ft. pendant hose for convenient one-man operation.

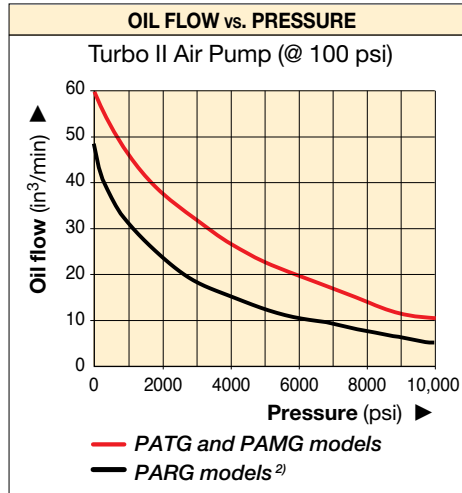

PATG PARG PAMG Series



Reservoir Capacity:

150 - 305 in³

Flow at Rated Pressure:

5 - 10 in³/min.

Maximum Operating Pressure:

10,000 psi

Pressure Rating (psi)	Output Flow Rate (in ³ /min)		Model Number	Valve Function	Air Pressure Range (psi)	Air Consumption (scfm)	Sound Level (dBA)
	No load	Load					
10,000	60	10	PATG & PAMG	Advance/	40-115	12	76
10,000	51 ¹⁾	6 ¹⁾					
10,000	48 ²⁾	5 ²⁾	PARG	Hold/ Retract	40-115	8	76

¹⁾ Air supply connected at pendant. ²⁾ Air supply connected at pump shown on flow curve.



Speed Chart

To determine how an 8000-Series pump will operate your cylinder, see the Pump/Cylinder Speed Chart in the "Yellow Pages".

Page: 409

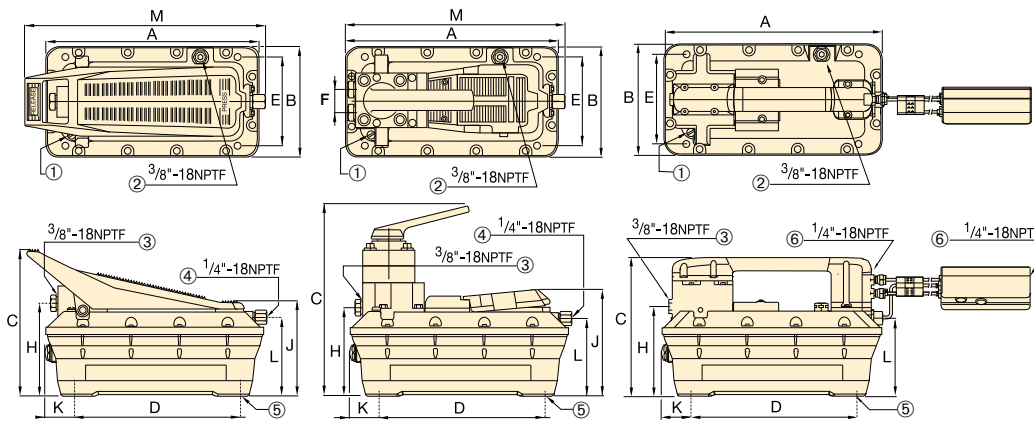

**PATG1102N
PATG1105N**

**PAMG1402N
PAMG1405N**

**PARG1102N
PARG1105N**

- ① Filtered "Permanent" Tank Vent
- ② Return-to-Tank/Auxiliary Vent/Fill Tank Port
- ③ Hydraulic Output
- ④ Swivel Air Input with Filter
- ⑤ 4 Mounting Holes for #10 thread forming screw. Max. depth into reservoir = 0.75"
- ⑥ Air Input Options

Dimensions (in)											Weight (lbs)	Model Number
A	B	C	D	E	F	H	J	K	L	M		
12.33	6.49	8.29	9.04	4.00	—	5.15	5.75	1.65	4.43	13.62	18	PATG1102N
15.60	7.92	8.22	9.04	4.00	—	5.08	5.75	3.28	4.41	17.20	22	PATG1105N
12.33	6.49	7.88	9.04	4.00	—	5.15	—	1.65	4.43	—	22	PARG1102N
15.60	7.92	7.88	9.04	4.00	—	5.08	—	3.28	4.41	—	26	PARG1105N
12.33	6.49	10.50	9.04	4.00	1.42	5.23	6.00	1.65	4.43	12.60	24	PAMG1402N
15.60	7.92	10.50	9.04	4.00	1.42	5.19	6.00	3.28	4.41	15.94	28	PAMG1405N

▼ Shown: **XA 11G**



Ex II 2 GD ck T4
IBExU, Germany

- Higher oil flow for increased productivity
- Variable oil flow and fine metering for precise control
- Ergonomic design for less operator fatigue
- Closed hydraulic system prevents contamination and allows pump usage in any position
- Pedal lock function for retract position
- External adjustable pressure setting valve
- **ATEX Certified.*** Includes ground screw for explosion protection

* See explanation of ATEX Certification in "Yellow Pages".

▼ Easily operated by foot. No need to fully lift up foot - rest body weight on heel, resulting in a hands-free and stable working position.



Control and Ergonomics



Optional Pressure Gauge

Integrated gauge with calibrated scale reading in psi, bar and MPa for actual pressure reading.



Optional 4-Way 3-Position Valve

For powering double-acting hydraulic cylinders and tools.



Optional 1/2 Gallon Reservoir

Double oil capacity for powering larger hydraulic cylinders and tools.



"Joy-stick" Lever Kit

Customer installed set of handles for manual operation of both pedals.

Order model number ¹⁾

XLK1



Hydraulic Swivel Connector

Customer installed swivel connector for optimal orientation of the hydraulic hose.

Order model number ¹⁾

XSC1

¹⁾ Accessories must be ordered separately.

Air Driven Hydraulic Pumps



PRODUCTION APPLICATION

XA11 pump is used with a 13-ton hollow cylinder to compress and position diesel engine valve springs.

The operator benefits from the fine metering capabilities to apply the mandatory precise stroke and force.

XA Series



Reservoir Capacity:
61 - 122 in³

Flow at Rated Pressure:
15 in³/min.

Air Consumption:
10 - 35 scfm

Maximum Operating Pressure:
10,000 psi

▼ XA-SERIES PERFORMANCE CHART

Maximum Pressure (psi)	Output Flow Rate (in ³ /min)		Pump Series	Valve Function	Dynamic Air Pressure (psi)	Sound Level (dba)
	No load	Load				
10,000	120	15	XA1	Advance/Hold/Retract	30-125	88

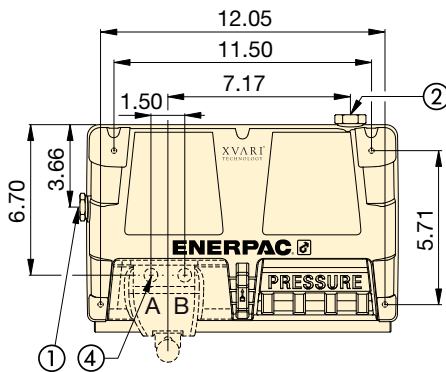

- ① 3/8"-18 NPTF Oil Outlet
- ② 1/4"-18NPTF Air Inlet
- ③ 4/3 Optional Control Valve
- ④ 3/8"-18 NPTF Oil Outlet

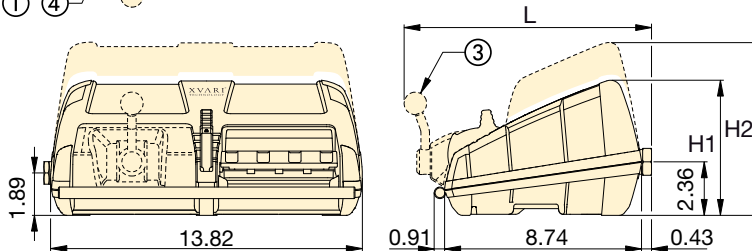

OIL FLOW vs. PRESSURE

at 100 psi dynamic air pressure

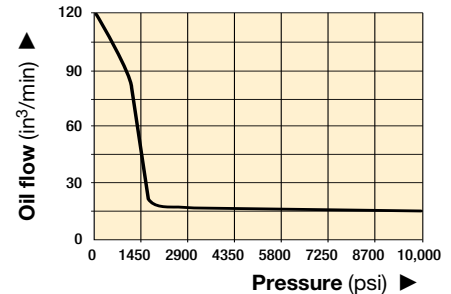

Regulator-Filter-Lubricator

Recommended for use with all XA-Series Air pumps. Provides clean, lubricated air and allows for air pressure adjustment.

Order model number ¹⁾

RFL102

▼ SELECTION CHART

For Use With Cylinder Tool	Usable Oil Capacity (in ³)	Model No. ¹⁾	Pressure Gauge	3-Way, 3-Position Valve	4-Way, 3-Position Valve	Dimensions (in)			Weight (lbs)
						H1	H2	L	
Single-acting	61	XA11 ²⁾	–	•	–	5.98	–	–	19.0
	122	XA12 ²⁾	–	•	–	–	6.69	–	22.4
Single-acting	61	XA11G	•	•	–	5.98	–	–	19.4
	122	XA12G	•	•	–	–	6.69	–	22.9
Double-acting	61	XA11V	–	–	•	5.98	–	10.98	22.3
	122	XA12V	–	–	•	–	6.69	10.98	25.7
Double-acting	61	XA11VG	•	–	•	5.98	–	10.98	22.7
	122	XA12VG	•	–	•	–	6.69	10.98	26.2

¹⁾ High-flow coupler CR400 and accessories must be ordered separately.

²⁾ Available as cylinder pump set, see page 63.

▼ Shown: ZA4208MX, ZA4420MX



Z

Tough.
Dependable.
Innovative.

CLASS

i **ATEX Certified**
See explanation of ATEX certification in the “Yellow Pages.”

Ex II 2 GD ck T4
DEKRA 0602

CE

Page: **399**

i **Speed Chart**
To determine how a ZA Series pump will operate your cylinder, see the Pump/Cylinder Speed Chart in the “Yellow Pages”.

Page: **409**

Hoses
Enerpac offers a complete line of high-quality hydraulic hoses. To ensure the integrity of your system, specify only genuine Enerpac hydraulic hoses.

Page: **148**

- Features Z-Class high efficiency pump design, higher oil flow and bypass pressure
- Two-speed operation and high by-pass pressure reduces cycle time for improved productivity
- Internal relief valves. One is factory set for overload protection while the second is user adjustable for pre-setting maximum system pressure
- Sight gauge on 1.2 and 1.8-gallon and level gauge on 2.6, 5.2 and 10.3-gallon reservoirs allow quick and easy oil level monitoring
- Optional heat exchanger warms exhaust air to prevent freezing and cools the oil

ZA4 Performance		
Dynamic Air Pressure Range	Air Consumption	Sound Level
(psi)	(scfm)	(dBA)
60-100	20-100	94-97

Used with Cylinder	Usable Oil Capacity (gal)	Valve Model Number ²⁾	Valve Function	Model Number	Output Flow Rate ¹⁾			
					(in ³ /min)			
					100 psi	700 psi	5,000 psi	10,000 psi
Single-acting	1.2	Manual VM32	Advance/Retract	ZA4204MX	850	675	110	80
	1.8			ZA4208MX	850	675	110	80
	5.2			ZA4220MX	850	675	110	80
Double-acting	1.2	Manual VM43	Advance/ Hold/ Retract	ZA4404MX	850	675	110	80
	1.8			ZA4408MX	850	675	110	80
	2.6			ZA4410MX	850	675	110	80
	5.2			ZA4420MX	850	675	110	80
	10.3			ZA4440MX	850	675	110	80

1) Actual flow will vary with air supply
2) See valve section for hydraulic symbols and details

ZA-Series, Air Hydraulic Pump Ordering Matrix

CUSTOM BUILD YOUR ZA4 AIR PUMP

▼ This is how a ZA-Series Pump model number is built up:



1	2	3	4	5	6	7	8				
Product Type	Motor Type	Flow Group	Valve Type	Usable Oil Capacity	Valve Operation	Voltage	Options				

1 Product Type

Z = Pump class

2 Motor Type

A = Air motor

3 Flow Group

4 = 80 in³/min@10,000 psi

4 Valve Type

- 0 = No valve with cover plate
- 2 = 3-way, 2-position (VM32)
- 3 = 3-way, 3-position (VM33)
- 4 = 4-way, 3-position (VM43)
- 6 = 3-way, 3-position, locking (VM33L)
- 7 = 3-way, 2-position (VM22)
- 8 = 4-way, 3-position, locking (VM43L)

5 Usable Oil Capacity

- 04 = 1.2 gallon
- 08 = 1.8 gallon
- 10 = 2.6 gallon
- 20 = 5.2 gallon
- 40 = 10.3 gallon

6 Valve Operation

- M = Manual valve
- N = No valve

7 Voltage

- X = Not applicable

8 Options

(Specify in alphabetical order)

- F = Filter
- G = 0-15,000 psi gauge (2 1/2")
- H = Heat exchanger*
- K = Skid bar*
- N = No reservoir handles (includes lifting eyes; 2.5, 5, 10 gallon only)
- R = Roll bars

* (1 and 2 gallon reservoirs only)

Ordering Example

Model Number: ZA4208MXFHK

ZA4208MXFHK is an air operated pump with a 3-way, 2-position manual valve, a 1.8 gallon reservoir, filter, heat exchanger and skid bar.

ZA Series



Reservoir Capacity:

1.2 - 10.3 gallon

Flow at Rated Pressure:

80 in³/min.

Maximum Operating Pressure:

10,000 psi

- ① User adjustable relief valve on all manual valves
 - ② Air inlet 1/2" NPTF
 - ③ Return Line Filter (optional)
 - ④ Oil Sight Gauge
 - ⑤ Roll Cage (optional)
 - ⑥ Oil Drain
 - ⑦ Lifting eyes (4) (optional)
 - ⑧ Handles
- Skid Bar (Model No. SBZ4) (optional)

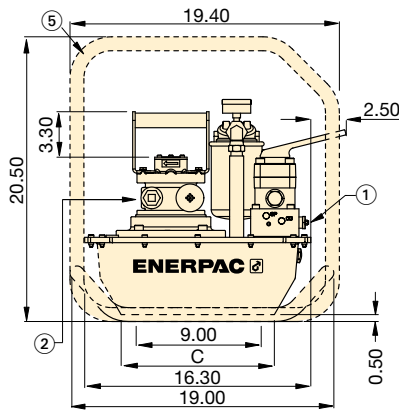

1.2 and 1.8 gallon reservoirs

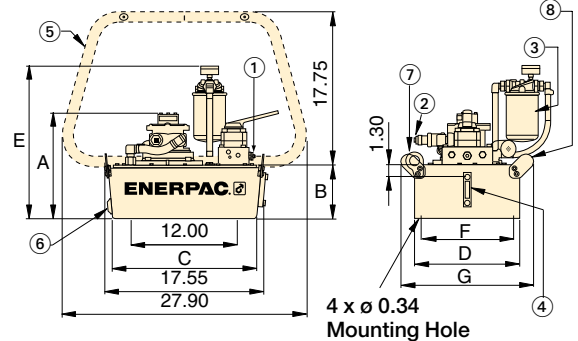
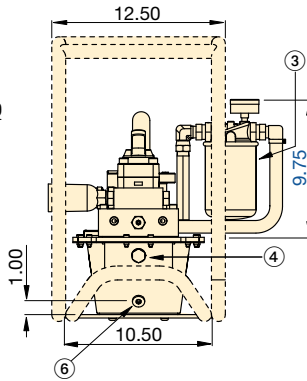

2.6, 5.2, 10.3 gallon reservoirs

Dimensions (in)							Weight (incl. oil) (lbs)
A	B	C	D	E	F	G	
11.6	5.6	11.0	6.0	15.4	-	-	65.5
11.6	5.6	11.0	8.1	15.4	-	-	75.7
13.0	7.1	16.5	16.6	16.0	15.6	18.4	112.7
11.6	5.6	11.0	6.0	15.4	-	-	66.7
11.6	5.6	11.0	8.1	15.4	-	-	76.9
12.0	6.1	16.5	12.0	16.0	11.0	15.1	87.1
13.0	7.1	16.5	16.6	16.9	15.6	18.4	113.9
16.5	10.6	15.7	19.9	20.4	18.9	23.0	164.6

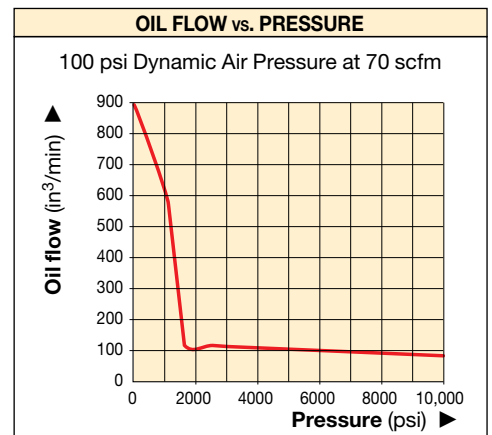

▼ Shown: ZG5420MX-R



Z

Tough.
Dependable.
Innovative.

CLASS



Speed Chart

To determine how a ZG Series pump will operate your cylinder, see the Pump/Cylinder Speed Chart in the “Yellow Pages”.

Page: 409



ZG-Series, Gasoline Pump Performance

Elevation can affect the performance of any gasoline engine. ZG-Series pumps are designed to develop rated performance at elevations up to 4921 ft.

For applications above this elevation please consult your Enerpac office.



User-Adjustable Relief Valve

All VM-Series directional valves have a user adjustable relief valve to allow the operator to easily set the optimum working pressure.

- Features Z-Class high-efficiency pump design, higher oil flow and bypass pressure
- Two-speed operation reduces cycle time for improved productivity
- Full-sight oil level glass on all reservoirs allow quick and easy oil level monitoring
- ZG5 is available in two 4-cycle engine sizes: 7.1 ft.lbs Honda and 8.5 ft.lbs Briggs & Stratton

▼ SELECTION CHART

Used with Cylinder	Usable Oil Capacity (gal)	Valve Model Number	Valve Function	Model Number with Roll Cage	Output Flow Rate (in ³ /min)				Sound Level (dBA)
					at 100 psi	at 700 psi	at 5000 psi	at 10,000 psi	
Single-Acting	2.6	VM33	Advance/ Hold/ Retract	ZG5310MX-R	700	650	110	100	88 - 93
	5.2			ZG5320MX-R	700	650	110	100	88 - 93
Double-Acting	2.6	VM43		ZG5410MX-R	700	650	110	100	88 - 93
	5.2			ZG5420MX-R	700	650	110	100	88 - 93
Single-Acting	2.6	VM33		ZG5310MX-BR	400	380	110	100	91 - 95
	5.2			ZG5320MX-BR	400	380	110	100	91 - 95
Double-Acting	2.6	VM43		ZG5410MX-BR	400	380	110	100	91 - 95
	5.2			ZG5420MX-BR	400	380	110	100	91 - 95
	10.3	VM43L		ZG5840MX-BR	400	380	110	100	91 - 95

*To order Briggs & Stratton motor, place a “B” suffix in the model number.

Gasoline Hydraulic Pumps

CUSTOM BUILD YOUR ZG AIR PUMP

▼ This is how a ZG-Series Pump model number is built up:

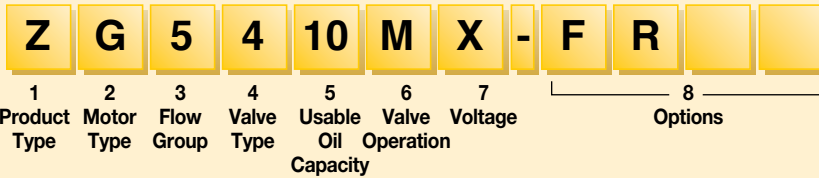

1 Product Type

Z = Pump class

2 Motor Type

G = Gasoline Engine

3 Flow Group

5 = 100 in³/min@10,000 psi

6 = 200 in³/min@10,000 psi (see page 130)

4 Valve Type

0 = No valve with coverplate ¹⁾

2 = 3-way, 2-position (VM32)

3 = 3-way, 3-position (VM33)

4 = 4-way, 3-position (VM43)

6 = 3-way, 3-position, locking (VM33L)

8 = 4-way, 3-position, locking (VM43L)

¹⁾ For remote valve mounting order **BSS1090** high pressure connecting plate.

5 Usable Oil Capacity (Reservoir Size)

10 = 2.6 gallon

20 = 5.2 gallon

40 = 10.3 gallon

6 Valve Operation

M = Manual valve

N = No valve

7 Voltage

X = Not applicable

8 Options

(Specify in alphabetical order)

B = Briggs & Stratton gasoline engine

F = Return Line Filter

G = 15,000 psi gauge

N = No reservoir handles (includes lifting eyes; 2.5, 5, 10 gallon only)

R = Roll bars

Ordering Example

Model Number: **ZG5420MXFR**

This is a 10,000 psi hydraulic pump, with a 4/3 manual valve, 2.6 gallon reservoir, with a 7.1 ft-lbs Honda gasoline engine pump, return-line filter and roll bar.

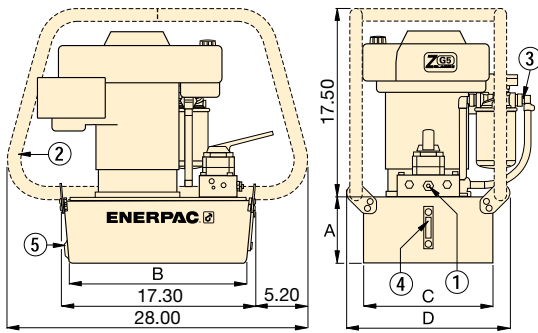

- ① User-adjustable relief valve on all manual valves. 3/8" NPTF on A and B ports; 1/4" NPTF on auxiliary ports.
- ② Roll Bar (optional)
- ③ Return Line Filter (optional)
- ④ Oil Level Gauge
- ⑤ Oil Drain

Motor Manufacturer*	Relief Valve Adjustment Range (psi)	ZG5 Dimensions (in)				Wt. (lbs)	Model Number with Roll Cage
		A	B	C	D		
Honda	1000-10,000	6.1	16.5	12.0	15.1	113.6	ZG5310MX-R
		7.1	16.3	16.6	19.7	140.9	ZG5320MX-R
		6.1	16.5	12.0	15.1	113.6	ZG5410MX-R
		7.1	16.3	16.6	19.7	141.0	ZG5420MX-R
Briggs & Stratton *	1000-10,000	6.1	16.5	12.0	15.1	111.0	ZG5310MX-BR
		7.1	16.3	16.6	19.7	138.3	ZG5320MX-BR
		6.1	16.5	12.0	15.1	111.1	ZG5410MX-BR
		7.1	16.3	16.6	19.7	138.4	ZG5420MX-BR
		10.6	15.7	19.8	21.9	189.6	ZG5840MX-BR

ZG5 Series



Reservoir Capacity:

2.6 - 5.2 - 10.3 gallon

Flow at Rated Pressure:

100 in³/min.

Engine Size:

7.1 and 8.5 Ft.lbs

Maximum Operating Pressure:

10,000 psi



High-Pressure Hoses

Enerpac offers a complete line of high-quality hydraulic hoses. To ensure the integrity of your system, specify only genuine Enerpac hydraulic hoses.

Page: 148



ZG6-Series 17.0 Ft-lb Pump

The ZG6 pump has a 200 in³/min. oil flow at 10,000 psi, Briggs & Stratton 4-cycle gasoline engine with electric start and 12 volt charge output for accessories.

Page: 130

OIL FLOW vs. PRESSURE

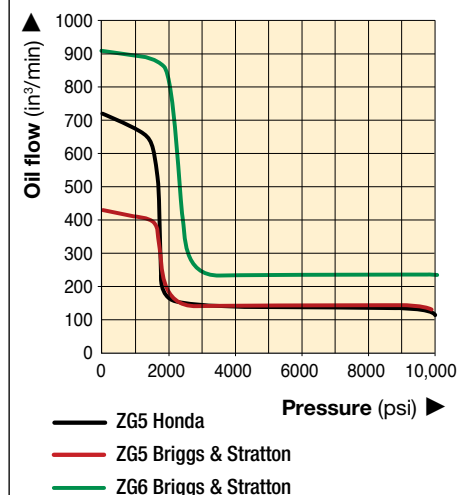

▼ Shown: ZG6440MXBCFH



ZG6 Series

Reservoir Capacity:
10.3 gallon

Flow at Rated Pressure:
200 in³/min.

Engine Size:
17.0 Ft.lbs

Sound Level:
88 - 93 dBA

Maximum Operating Pressure:
10,000 psi

- Features **Z-Class** high-efficiency pump design:
 - higher oil flow and bypass pressure
 - patented balanced rotating pump components to reduce vibration
 - replaceable piston check valves that increase service life of pump components
- Two-speed operation reduces cycle time for improved productivity
- Full-sight oil level glass on all reservoirs allow quick and easy oil level monitoring
- Sturdy wheeled cart allows transport over uneven terrain and features collapsible handles
- Dual forced-air heat exchangers stabilizes hydraulic oil temperature
- Roll cage for easy portability and hoisting, protects pump
- Briggs & Stratton 17 ft.lbs engine with electric start, pressurized oil and 16-amp charge output for accessories



Other Options Available

The ZG5/ZG6 pumps are available in a wide range of configurations and options.

Contact Enerpac for further information.



User Adjustable Relief Valve

All VM-Series directional valves have a user adjustable relief valve to allow the operator to easily set the optimum working pressure.

Used with Cylinder	Usable Oil Capacity (gal)	Valve Model Number	Valve Function	Model Number	Motor Manufacturer*	Motor Size (Ft.lbs)	Weight (lbs)
Double-Acting	10.3	VM43	Advance/Hold/Retract	ZG6440MX-BCFH	Briggs & Stratton	17.0	334.0

8000-Series Gasoline Pumps

▼ Shown: EGM8418



EGM Series

Reservoir Capacity:

25 gallon

Flow at Rated Pressure:

1.5 gal/min.

Motor Size:

18 hp

Maximum Operating Pressure:

10,000 psi



Locking Valves

Pumps with VM4 manual valves are available with VM4L manual valves for positive load holding. Add suffix "L" to pump model number.

Page: 140

- Industrial grade 18 hp twin-cylinder motor
- Panel mounted pressure gauge and adjustable relief valve for system pressure control
- Two-speed pump design with high by-pass pressure for rapid cylinder advance
- Built in oil temperature and oil level gauge
- External adjustable relief valve (1,200-10,000 psi) allows control of operating pressure without opening the pump
- Integral priming circuit guarantees quick starts after transport

OIL FLOW vs. PRESSURE

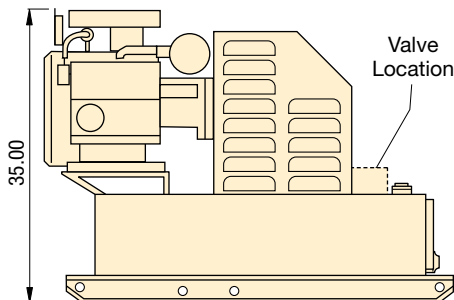
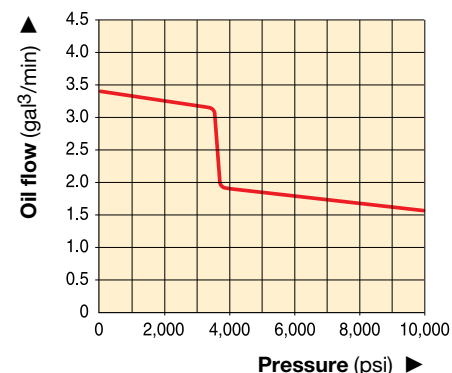

Side View

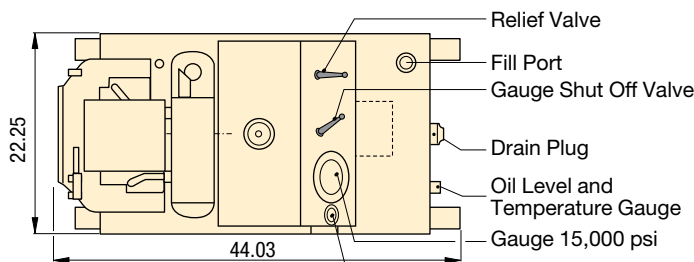

Top View

Used with Cylinder	Usable Oil Capacity (gal)	Model Number	Pressure Rating (psi)		Output Flow Rate (gal/min)		Valve Type	Valve Function	Sound Level (dBA)	Weight (lbs)
			1 st stage	2 nd stage	1 st stage	2 nd stage				
Single-acting	18	EGM8218	3,700	10,000	3.4	1.5	3-way, 2-pos.	Adv./Retr.	94	890
Double-acting	18	EGM8418	3,700	10,000	3.4	1.5	4-way, 3-pos.	Adv./Hold/Retr.	94	890

▼ SFP414SJ and SFP403SJ (Gauges and retract valves not shown)



Multiple Outlets with Equal Flow for Lifting and Lowering



Typical Split-Flow Pump Applications

For lifting and lowering applications on multiple points, Split-Flow Pumps are a far better alternative than using independently operated pumps. Where synchronization of maximum 4% is acceptable, Split-Flow Pumps are a safe and economical solution.

The SFP-Series pumps feature both single and synchronized multiple outlet control either through joystick or pendant operation.

Application examples:

- Bridge deck lifting for bearing maintenance
- Stage lifting in construction and shipbuilding
- Skidding to move structures and buildings
- Levelling of constructions like wind turbines

- 2, 4, 6 or 8 split-flow outlets
- Individual or simultaneously operation of valves, with advance/hold/retract function
- Joystick (manual) controlled or pendant (solenoid) controlled valves
- Flow per outlet ranging from 20 to 153 in³/min at 10,000 psi
- For double- and single-acting cylinders
- Adjustable pressure relief valve per circuit
- Reservoir sizes: 5, 10 or 40 gallons
- All models include pressure gauges

▼ Step-by-step stage lifting an old windmill using double-acting RR506 cylinders powered by a Split-Flow Pump.



Remote Control Pendant

Split-Flow Pumps with solenoid valves include a remote pendant with selector switches for each individual outlet, allowing single or multiple cylinder operation.



Hoses and Couplers

Enerpac offers a complete line of high-quality hydraulic hoses. To ensure the integrity of your system, specify only genuine Enerpac System Components.

Split-Flow Pumps

SFP Series



Reservoir Capacity:

5, 10 or 40 gallon

Split-Flow Outlets:

2, 4, 6 or 8 outlets

Flow at Rated Pressure:

20 - 153 in³/min

Motor Size:

1 - 20 hp

Maximum Operating Pressure:

10,000 psi

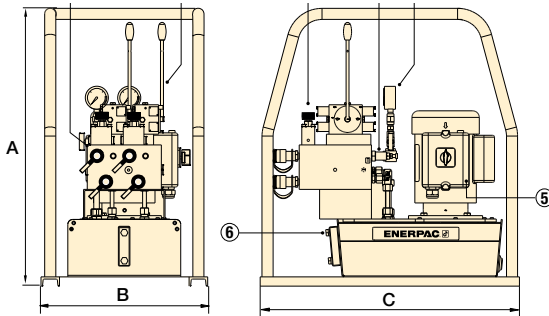

◀ SFP-Series with 5-gallon reservoir (shown with 2 split-flow outlets)

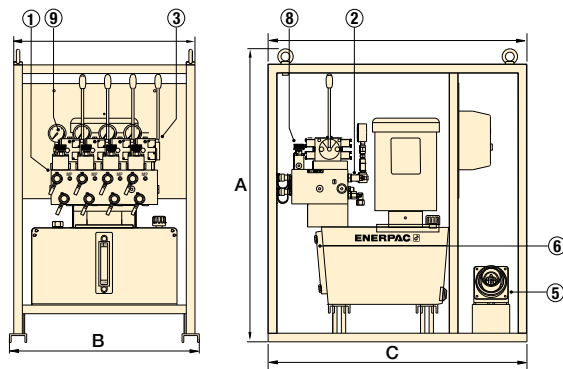

◀ SFP-Series with 10-gallon reservoir (shown with 4 split-flow outlets)

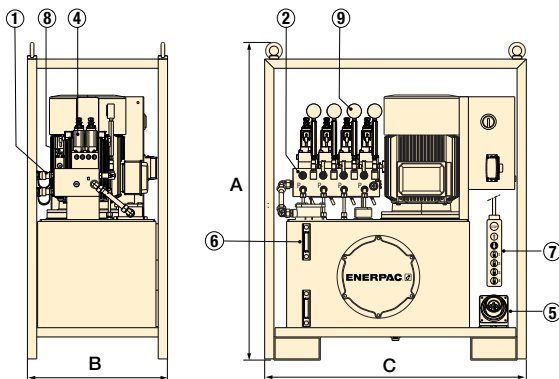

◀ SFP-Series with 40-gallon reservoir (shown with 4 split-flow outlets)



Lifting Cylinders

For a complete line of Enerpac cylinders, see the Cylinder and Lifting Products in our catalog.

Page: 5

- ① Manifold with split-flow outlets and CR400 couplers
- ② Adjustable pressure relief valve per circuit
- ③ Manual 4/3 control valves with joysticks
- ④ Solenoid 4/3 control valves (24 VDC)
- ⑤ Power Socket
- ⑥ Oil sight gauge(s)
- ⑦ Remote control pendant with 16 ft. cord
- ⑧ Flow control valve
- ⑨ Hydraulic gauge

Number of Split-Flow Outlets	Reservoir Size (gal)	Oil Flow per Outlet @ 10,000 psi (in ³ /min)	Pump Model Number 4/3 Valve Operation Advance/Hold/Retract		Motor Size 460 V, 3ph 60 Hz (hp)	Dimensions (inch)			Weight (lbs)
			Manual (Joystick)	24 V Solenoid (Pendant)		A	B	C	
2	5	20	SFP202MB	—	1.0 *	29.4	17.7	27.6	253
	10	22	SFP403MJ	SFP403SJ	3.0	40.0	25.2	38.2	565
4	40	65	—	SFP409SJ	7.5	53.4	23.8	45.7	1045
	40	101	—	SFP414SJ	10	53.4	23.8	45.7	1078
	40	153	—	SFP421SJ	15	53.4	23.8	45.7	1311
6	40	94	—	SFP613SJ	15	53.4	31.7	47.2	1236
8	10	22	—	SFP803SJ	7.5	45.8	32.7	43.8	990
	40	94	—	SFP813SJ	20	53.4	31.7	47.2	1364

* 115V-1 ph, 60 Hz



Motor Voltage

Motor voltage is specified by the last letter in the model number.

Other motor voltages are available from Enerpac. Change "J" in the model as follows for other options:

G = 208-240V, 3 ph, 50-60 Hz

W = 380-415V, 3 ph, 50-60 Hz

▼ SFP-Series Split-Flow Pump Kit Components



Connecting Split-Flow Pumps for more lift points and greater accuracy

- Control multiple Split-Flow Pumps with one control unit
- Pumps can be closer to the lifting points, requiring shorter hoses and increasing accuracy
- Synchronize all lift points to within 0.04 inch (1.0 mm)
- Network control boxes expand the number of lifting points by combining up to four split-flow pumps together, simplifying lifting operations by using a single operator station
- Plug and play synchronous lift upgrade kits limit initial investment and provide everyday flexibility to tailor the controls to the applications needs



Split Flow Pumps Kits

SFP Series kits are customized from standard components to meet the needs of your unique applications. On the next page is the guide to help you choose the right components to upgrade or expand your equipment based on your application needs. Contact your regional Enerpac representative / territory manager for support with your specific project.

Split-Flow Pump Network Kits

Split-Flow Pump Network Kits connect multiple Split-Flow Pumps under one control system.

Split-Flow Pump Synchro Kits

Split-Flow Pump Synchro Kits connect and electronically synchronize each lift point of a single Split-Flow Pump or multiple Split-Flow Pumps under one control system.



Junction Box

SFPKSS4 and SFPKSS8

junction boxes consolidate the signals from pressure and stroke sensors, allowing the master control box to synchronize the lifting operation.



SFPKMN, Master Control Box

All SFP-Series Synchro Kits include a master control box to allow the operator to

easily monitor and control a multi-point synchronized lift and adjust individual lift points as needed.

All master control boxes feature an industrial grade touch screen and a user-friendly interface.



Stroke Sensor Cable,

Can be connected together for additional length. Ordered separately, requires one for each stroke sensor.

Model Number	Length (ft)	Model Number	Length (ft)
EVO-SC-6	19.7	EVO-SC-25	82



EVO-WSS, Wire Stroke Sensors

Provides stroke feedback to controls. Includes magnets for mounting. Ordered separately,

requires one sensor for each lifting point. Available in measuring range from 14.8 to 39.4 inch.

Model Number	Range (in)	Model Number	Range (in)
EVO-WSS-375	14.8	EVO-WSS-1000	39.4
EVO-WSS-500	19.7	-	-



Communication Cables

EVO-COMM-Series communication cables transfer information about the synchronized lift operation

from the master control panel to each of the connected split-flow pumps.

Model Number	Length (ft)	Model Number	Length (ft)
EVO-COMM-25	82	EVO-COMM-75	246
EVO-COMM-50	164	EVO-COMM-100	328



Upgrading Split-Flow Pumps

To network multiple SFP-pumps together with standard function see drawing and table ①.

To upgrade a single SFP-pump to synchronous lift capability, see drawing and table ②.

To upgrade and network multiple SFP-pumps together with synchronous lift capabilities, see drawing and table ③.

SFP Series



Multiple Pumps in Network System:

1 - 4 Pumps

Maximum Lifting Points:

32x Cylinders

① Networked SFP-Pumps in Standard Operation

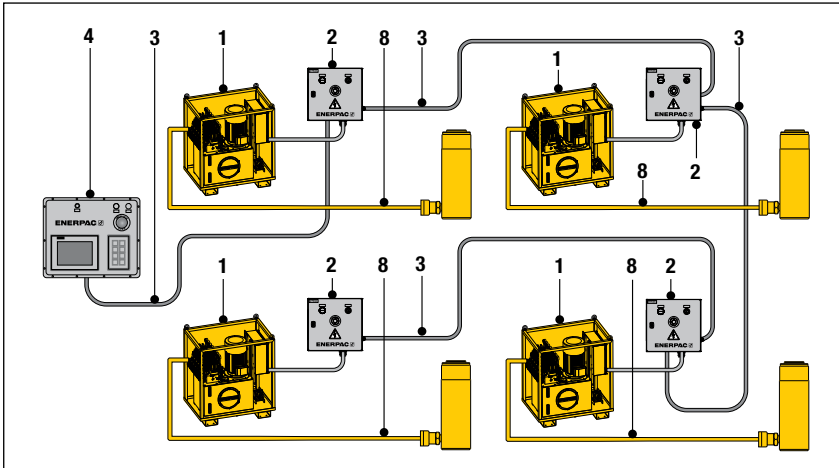

① Networked SFP-Pumps in Standard Operation

No.	Qty.	Model No. & Description
1	4x	SFP...SW Pumps with solenoid valves
2	4x	SFPKSN Junction Box, 1x per pump
3	4x	SFPCOMM25 Communication Cable, 1x per pump
4	1x	SFPKMN Master Control Box
8		HC-700-Series, Hydraulic Hoses

② Single SFP-Pump in Multiple-Point Synchronous Lifting Operation

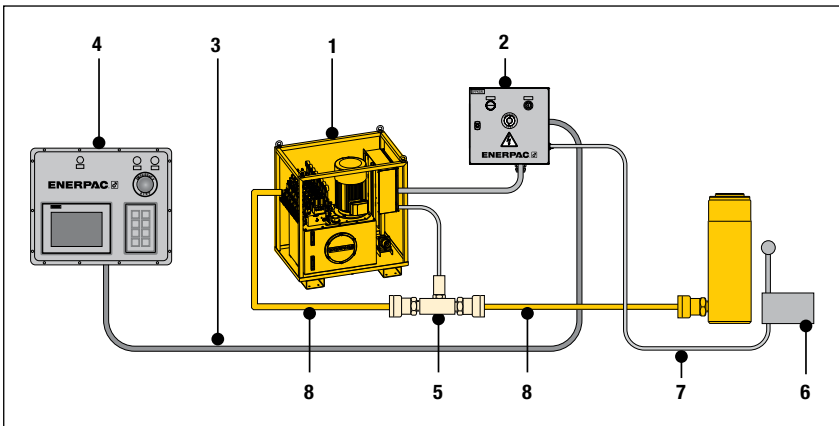

② Single SFP-Pump in Multiple-Point Synchronous Lifting Operation

No.	Qty.	Model No. & Description
1	1x	SFP...SW Pump with solenoid valves
2	1x	SFPKSS4 Junction Box for 2-4 lifting points or SFPKSS8 for 6-8 lifting points
3	1x	SFPCOMM25 Communication Cable
4	1x	SFPSSC Single Slave Control Box
5		SFPKPT Pressure Transducer Kit (1x per cylinder A-port)
6		EVO-WSS-XXX Stroke Sensor, 1x per cylinder
7		EVO-SC25 Stroke Sensor Cable, 1x per cylinder
8		HC-700-Series, Hydraulic Hoses

③ Networked Pumps in Multiple-Point Synchronous Lifting Operation

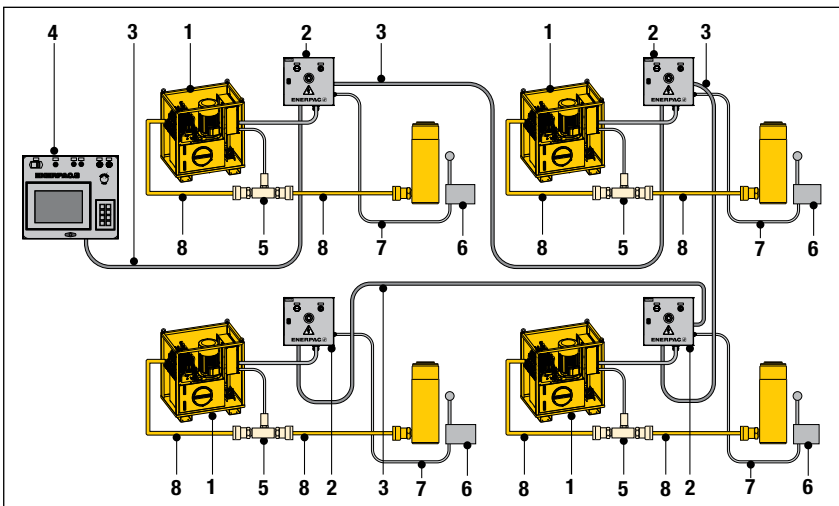

③ Networked SFP-Pumps in Multiple-Point Synchronous Lifting Operation

No.	Qty.	Model No. & Description
1	4x	SFP...SW Pump with solenoid valves
2	4x	SFPKSS4 Junction Box, 1x per pump, for 2-4 lifting points or SFPKSS8 Junction Box for 6-8 lifting points)
3	4x	EVO-COMM-XXX Communication Cable, 1x per pump
4	1x	EVOMASTER Master Control Box
5		SFPKPT Pressure Transducer Kit, 1x per cylinder A-port)
6		EVO-WSS-XXX Stroke Sensor, 1x per cylinder
7		EVO-SC25 Stroke Sensor Cable, 1x per cylinder
8		HC700-Series, Hydraulic Hoses

▼ EVO8 (shown with 4 cylinders and stroke sensors, (sold separately))



- Modular lifting pumps to control 4, 8 or 12 lifting points
- Can be connected to single- or double-acting cylinders with the same or different lifting capacities
- PLC-controlled system with integrated 10,000 psi hydraulic power unit and 66-gallon reservoir
- Network capability to link up to 4 EVO units (HPUs) to a separate EVO master-control box via wireless control
- Intuitive user interface providing easy set up, control and navigation
- Data storage and recording capabilities
- Variable frequency drive motor (VFD) and PLC for precise synchronization and oil flow control

▼ Shown: 3600-ton tunnel boring machine lowered and tilted into its starting position with the EVO-Series Synchronous Lifting System.



The Multi-Functional Synchronous Lifting System



EVO-System Work Modes

The application possibilities are infinite with the standard EVO-System, powering interlinked hydraulic cylinders – single or double-acting, push or pull, stage lift, hollow plunger or lock nut cylinders. The EVO-System has 9 work modes. The operator can navigate to any of these menus:

1. Manual
2. Pre-Load
3. Automatic
4. Retract Fast
5. Depressurize
6. Tilting
7. Stage Lift
8. Weighing *
9. Center of Gravity determination *

* Available in the **EVO-W-models**.



Typical Synchronous Lifting Applications

- Bridge lifting and repositioning
- Bridge launching
- Bridge maintenance
- Incremental launching and box jacking
- Lifting and lowering of heavy equipment
- Lifting, lowering, levelling and weighing of heavy structures and buildings
- Structural and pile testing
- Lifting and weighing of oil platforms
- Foundation levelling of onshore and offshore wind turbines
- De-propping/load transfer from temporary steel work
- Foundation shoring

Synchronous Lifting Systems



Benefits of the EVO-Series System

Precise control of multiple lift points

- Comprehensive understanding and management of a lifting operation from a central control system improves safety and operational productivity
- Programmable synchronized lifting
- Automatic stop at pre-set cylinder stroke or load limit

Safe and efficient movement of loads

- System secured with warning and stop features to realize optimal safety

High accuracy

- Variable frequency drive (VFD) and PLC for precise synchronization and control of oil flow, stroke and speed
- Depending the cylinder capacities used, an accuracy of 0.040 inches between lifting points is achieved

Ease of operation

- User friendly interface: visual screens, icons, symbols and color coding

- A single operator controls the entire operation

Monitoring and Data Recording

- Displays data of the operation.
- Data recording at user-defined intervals
- Data storage and read-out for reporting

Network capability

- Ethernet IP protocol for communication between hydraulic power units, allow easy “plug and play”

EVOW Weighing System

Weighing applications with 1% accuracy

- Includes calibrated sensors and auto-calibration of external load cells
- Center of gravity determination functionality
- Parameters for “waiting time for stabilization” and “number of cycles”.

Global standardized system

- Enerpac global coverage ensures local support

EVO Series



Number of Lifting Points:

4, 8, 12 (up to 48)

Reservoir Capacity:

66 gallon

Flow at Rated Pressure:

46 - 292 in³/min.

Motor Size:

4 - 10 hp

Maximum Operating Pressure:

10,000 psi



Stroke Sensors and Cables

Optional accessories required for each lifting point and stroke sensor.

Page: 134

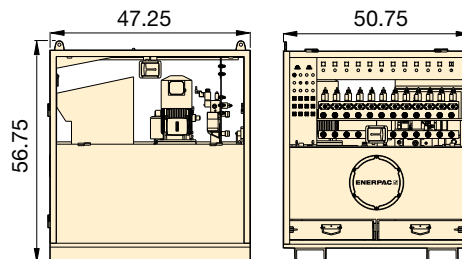

EVO-Series (Standard)

Lifting Points	Variable Oil Flow (in ³ /min)		Model Number 460-480V, 3ph, 50-60Hz	Usable Oil Capacity (gal)	Motor Size (hp)	Motor Speed ²⁾	Wt. (lbs)
	(< 1,800 psi)	(> 1,800 psi)					
4	243-812	46-153	EVO 421460	66	4	VFD	2000
4	243-812	46-153	EVO 421460 W¹⁾	66	4	VFD	2000
4	285-951	88-292	EVO 440460	66	10	VFD	2210
4	285-951	88-292	EVO 440460 W¹⁾	66	10	VFD	2210
8	243-812	46-153	EVO 821460	66	4	VFD	2000
8	243-812	46-153	EVO 821460 W¹⁾	66	4	VFD	2000
8	285-951	88-292	EVO 840460	66	10	VFD	2000
8	285-951	88-292	EVO 840460 W¹⁾	66	10	VFD	2000
12	243-812	46-153	EVO 1221460	66	4	VFD	2025
12	243-812	46-153	EVO 1221460 W¹⁾	66	4	VFD	2025
12	285-951	88-292	EVO 1240460	66	10	VFD	2250
12	285-951	88-292	EVO 1240460 W³⁾	66	10	VFD	2250

¹⁾ Model numbers with suffix **W** are pumps for weighing systems.

²⁾ VFD = Variable Frequency Drive 18-60 Hz.



EVO-Master Control Box

Required to link up to 4 standard EVO-pumps together to achieve a maximum of 48 lifting points. Contact Enerpac for more information.

▼ Precision levelling caisson pier box: 3 EVO-Systems connected with 32 jacks lowered the 1100-ton bascule pier box.



Enerpac offers a wide variety of hydraulic pumps for all your custom needs.

Hydraulic pumps are at the heart of any hydraulic system. Different systems require different flow, pressure and control. Enerpac offers a wide variety of hydraulic pumps from small hand-operated pumps to large gasoline powered pumps. Still many applications require a customized pump to operate

the system. These may include larger reservoir capacity, custom valve configurations or added electrical controls.

Enerpac also specializes in power units and controls used for synchronous lifting/lowering of multiple jacking points.



◀ *Private labeled electric torque wrench pumps for OEMs.*



◀ *Custom pumps with control packages.*



◀ *Pumps with custom valve manifolds and circuits.*

OVERVIEW



▲ *Custom hydraulic pump for a bridge deck launching system.*

CUSTOMIZABLE FEATURES:





- Reservoir and Frame
- Valve Configurations
- Controls
- Oil Types
- Seals
- Pressure and Flow
- Coolers and Heaters
- Paint
- Motor Type
- Human Machine Interface (HMI)

Directional Control Valves Section Overview

Enerpac hydraulic valves are available in a wide variety of models and configurations.

Whatever your requirements... directional control, flow control, or pressure control... you can be sure that Enerpac has the correct valve to match your application exactly.

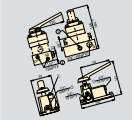
Designed and manufactured for safe operation up to 10,000 psi, the range of Enerpac valves allows for direct pump mounting, remote mounting, manual or solenoid actuation, and in-line installation, giving you flexible solutions to control your hydraulic system.

Valve Type	Series		Page
Pump-Mounted Directional Control Valves	VM, VE		140 ▶
Remote-Manual Directional Control Valves	VC		142 ▶
Valve Dimensions	VC, VM, VE		143 ▶
Modular/Solenoid Operated Directional Control Valves	VE		144 ▶



Pressure and Flow Control Valves

For more hydraulic system control with pressure relief valves, shut-off valves, check valves and sequence valves see our "System Components" section.

Page: 147



Valving Help

See Basic System Set-Up and Valve Information in our 'Yellow Pages'

Page: 404



▼ Shown from left to right: VM32, VE33, VM33, VM43L, VE43



- Advance/Retract and Advance/Hold/Retract operation of single-acting and double-acting cylinders
- Manual or solenoid operation
- Pump mounting will retrofit on most Enerpac pumps
- Available “locking” option on VM Series valves for load-holding applications
- Standard “locking” feature on VE Series 3-position valves
- User adjustable relief valves allow the operator to easily set the working pressure

Venturi Valve Technology

- For fast return of single-acting gravity and spring-return cylinders
- Available as manual or solenoid valve on ZU4- and ZE-Series electric pumps
- Retrofit Venturi valve kits for field installation on existing ZU4- and ZE-Series electric pumps



Adjustable Relief Valve

All valves feature several gauge ports for “system”, A port and B port pressure monitoring.

User-adjustable relief valves are included on all models to allow the operator to easily set the optimum working pressure for each application. VM33 and VE43 valves include “System Check” feature, for more precise pressure holding and improved system control. The VM33 has

improved porting which provides faster cylinder retraction while motor is running.

Locking Valves

For applications that require positive load holding, VM-Series valves (except VM22 and VM32) are available with a pilot-operated check valve. This option provides hydraulic locking of the load until the valve is shifted into the retract position.

For Reliable Control of Single and Double-Acting Cylinders

Valve Operation	Used with Cylinder	Valve Type	
Manual	Single-acting	3-Way 2 Position	
Manual	Single-acting	3-Way 2 Position	
Manual	Single-acting	3-Way 3 Position, Tandem Center	
Manual	Single-acting ONLY	3-Way 3 Position, Tandem Center, Venturi Return Assist	
Manual	Double-acting	4-Way 3 Position, Tandem Center	
Manual	Single-acting	3-Way 3 Position, Tandem Center, Locking	
Manual	Double-acting	4-Way 3 Position, Tandem Center, Locking	
Solenoid 24 VDC	Single-acting	3-Way 2 Position	
Solenoid 24 VDC	Single-acting	3-Way 2 Position, Dump	
Solenoid 24 VDC	Single-acting ONLY	3-Way 3 Position, Tandem Center, Venturi Return Assist	
Solenoid 24 VDC	Single-acting	3-Way, 3 Position, Tandem Center	
Solenoid 115 VAC	Single-acting	3-Way, 3 Position, Tandem Center	
Solenoid 24 VDC	Double-acting	4-Way, 3 Position, Tandem Center	
Solenoid 115 VAC	Double-acting	4-Way, 3 Position, Tandem Center	

For remote valve applications, see page 142.

Pump Mounted Directional Control Valves



Assisted Return Pumps

To improve productivity and plunger retraction, Enerpac offers valve

configurations designed to accelerate your cylinder retraction speeds. ZU4

and ZE-Series pumps feature Venturi valve technology to facilitate the faster return of single-acting gravity return cylinders. See details on www.enerpac.com

VM, VE Series



Flow Capacity:

4.5 gal/min.

Maximum Operating Pressure:

10,000 psi



Assisted Return Pumps with Venturi Valve Technology

To improve productivity and plunger retraction, Enerpac

offers valve configurations designed to accelerate your cylinder retraction speeds, ZU4 and ZE-Series pumps feature Venturi Valve Technology to facilitate the faster return of single-acting gravity return cylinders. See valve type in ZU4 and ZE-pump ordering matrix on pages 109 and 115.

Venturi Valve Retrofit Kits

For field installation on existing ZU4, ZE and ZA-Series pumps, Retrofit Kits are available for manual and solenoid operated valves.

Model Number	Hydraulic Symbol	Schematic Flowpath			Weight (lbs)
		Advance	Neutral	Retract	
VM22					5.6
VM32					5.6
VM33					6.7
VM33VAC					7.5
VM43					6.8
VM33L					10.7
VM43L					10.8
VE32 ¹⁾					8.7
VE32D ¹⁾					8.7
VE33VAC ¹⁾					22
VE33 ¹⁾					20.3
VE33-115					20.3
VE43 ¹⁾					20.3
VE43-115					20.3

¹⁾ When ordering Enerpac VE-Series solenoid valves, the pendant must be ordered separately for Z-Class Pumps See page 143 for product dimensions.

▼ Shown from left to right: **VC20, VC4L**



Reliable Remote Control



Locking Valves

For applications that require positive load holding, VC and VM Series valves are available with a pilot-operated check valve. This option provides hydraulic locking of the load until the valve is shifted into the retract position.

- Advance/Hold/Retract operation for use with single-acting or double-acting cylinders
- Return line kit included with remote valves

Valve Operation	Used with Cylinder	Valve Type	Model Number	Hydraulic Symbol	Schematic Flowpath			Weight (lbs)
					Advance	Hold	Retract	
Manual	Single Acting	3-Way, 3 Position, Tandem Center	VC3					6.4
Manual	Single Acting	3-Way, 3 Position, Tandem Center, Locking	VC3L					10.3
Manual	Single Acting	3-Way, 3 Position, Closed Center	VC15					6.4
Manual	Single Acting	3-Way, 3 Position, Closed Center, Locking	VC15L					10.3
Manual	Double Acting	4-Way, 3 Position, Tandem Center	VC4					6.4
Manual	Double Acting	4-Way, 3 Position, Tandem Center, Locking	VC4L					10.3
Manual	Double Acting	4-Way, 3 Position, Closed Center	VC20					6.4
Manual	Double Acting	4-Way, 3 Position, Closed Center, Locking	VC20L					10.3

Return line kit included with remote valves

VC, VM, VE-Series, Valve Dimensions

Pump Mounted Directional Control Valves

Valve dimensions in inches.

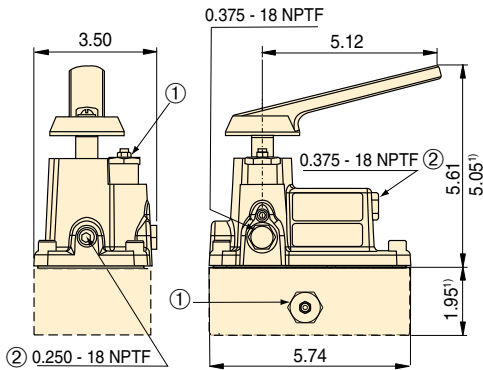

- ① User Adjustable Relief Valve
- ② Auxiliary Port

VC, VM, VE Series



Flow Capacity:

4.5 gal/min.

Maximum Operating Pressure:

10,000 psi

VM22, VM32

¹⁾VM22 only

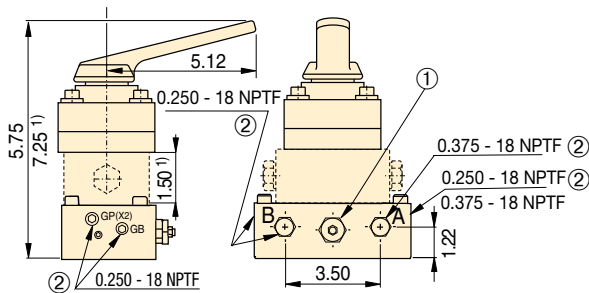

VM33, VM33L, VM43, VM43L

¹⁾VM33VAC, VM33L and VM43L only

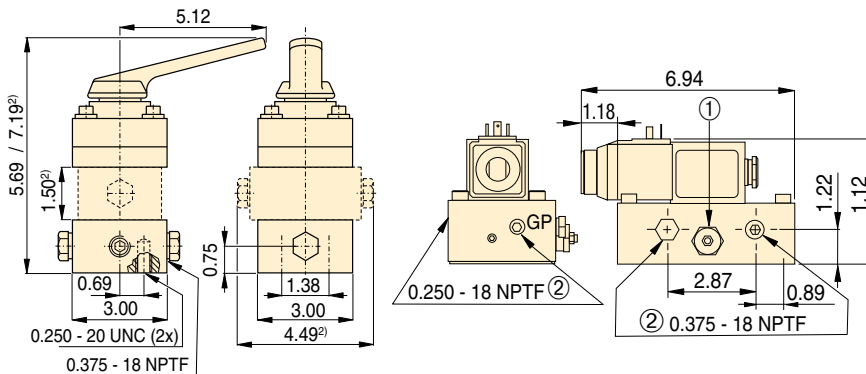

**VC3, VC3L, VC15, VC15L
VC4, VC4L, VC20, VC20L**

VE32, VE32D

²⁾ VC3L, VC15L, VC4L and VC20L only



Gauges

Minimize the risk of overloading and ensure long, dependable service from your equipment. Refer to the System Components section for a full range of gauges.

Page: 147



Fittings

For additional fittings see the fitting page of the System Components section.

Page: 153



Valving Help

See Basic System Set-Up and Valve Information in our 'Yellow Pages'

Page: 399

Remote Manual Directional Control Valves

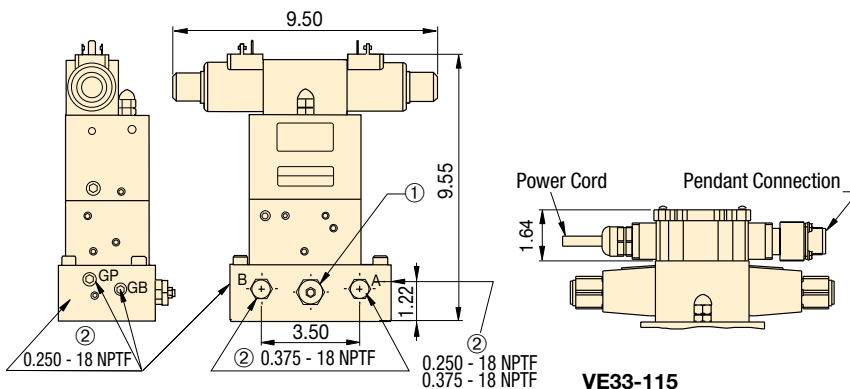

VE33, VE43

**VE33-115
VE43-115**

▼ Shown top to bottom: VEC15600D, VEK15000B, VEC15000B



- Ideal for independent control of multiple cylinders or functions
- Relief valve and pilot-operated check accessory valves are stackable between manifold and valve body
- Remote and pump mounting

Valve Flow Path	Used with Cylinder	Valve Code	Hydraulic Symbol
4-Way, 3-Position (4/3) Open Center	Double-acting	A	
4-Way, 3-Position (4/3) Closed Center	Double-acting	B	
4-Way, 3-Position (4/3) Tandem Center	Double-acting	C	
4-Way, 3-Position (4/3) Float Center	Double-acting	D	
4-Way, 2-Position (4/2) Crossover Offset	Double-acting	E	
3-Way, 3-Position (3/3) Tandem Center	Single-acting	F	
3-Way, 3-Position (3/3) Closed Center	Single-acting	G	
2-Way, 2-Position (2/2) Normally Closed	System	H*	
2-Way, 2-Position (2/2) Normally Open	Un-loading	K*	
4-Way, 2-Position (4/2) Float Offset	Double-acting	M	
3-Way, 2-Position (3/2) Normally Open	Single-acting	P	

* Requires use of tank port for dump or unloading.

Unmatched Combinations and Possibilities



3-Way Check Valve

Use a **VS51** 3-way pilot operated check valve assembly to convert your 3-way modular valve into a load-holding valve.



4-Way Check Valve

Use a **VS61** 4-way pilot operated check valve assembly to convert your 4-way modular valve into a load-holding valve.



System Pressure Control

To add system pressure control to your modular valve, order **VS11 Relief Valve** assembly.

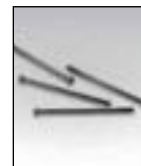

Bolt Kits for Accessory Valves With No Manifold

Order Bolt Kit **BK2** when adding one of the accessory valves. Order Bolt Kit **BK3**

when adding any combination of two accessory valves.

How to order one of the 1,300 possible model numbers?

With over 1,300 possible model numbers, Enerpac has the perfect valve for you. Use the "chart" to build your own valve for the specific application you require. This is the complete guide to all the Modular valves that are available.

VE-Series Solenoid Operated Valves Ordering Matrix

CUSTOM BUILD YOUR MODULAR VALVES

▼ This is how a Modular Valve Model Number is built up:



1 Solenoid Operated Valve 2 Valve Flow Path 3 Flow Capacity 4 Voltage 5 Accessory Valves 6 Manifold

1 Product Type

VE = Solenoid Operated Valve

2 Valve Code

- A** = 4/3 Open Center
- B** = 4/3 Closed Center
- C** = 4/3 Tandem Center
- D** = 4/3 Float Center
- E** = 4/2 Crossover Offset
- F** = 3/3 Tandem Center
- G** = 3/3 Closed Center
- H** = 2/2 Normally Closed
- K** = 2/2 Normally Open
- M** = 4/2 Float Offset
- P** = 3/2 Normally Open

3 Flow Capacity

1 = 4 gallons per minute

4 Voltage

- 1** = 24 VDC
- 2** = 220/240 V, 1 ph, 50 Hz
- 5** = 115 V, 1 ph, 60 Hz

5 Accessory Valves

- 000** = No accessory valves
- 100** = Relief Valve only
- 150** = Relief Valve and 3-way pilot operated check valve
Only for VEF/VEG
- 160** = Relief Valve and 4-way pilot operated check valve
Only for VEA/VEB/VEC/VED
- 500** = 3-way pilot operated check valve
Only for VEF/VEG
- 600** = 4-way pilot operated check valve
Only for VEA/VEB/VEC/VED

6 Manifold

- A** = No manifold**
- B** = Remote Mounted
- D** = Pump Mounted*

* Only for valve code: **VEA/VEC/VEF**

** Must order Bolt Kit separately.

Example: VEA15600-D

VEA15600-D is a Modular Valve with a 4-way, 3-position open center flowpath, 115 VAC, and an integral pilot-operated check valve, for mounting on an Enerpac pump.

VE Series



Flow Capacity:

4 gal/min.

Maximum Operating Pressure:

10,000 psi

Pressure Drop versus Oil Flow

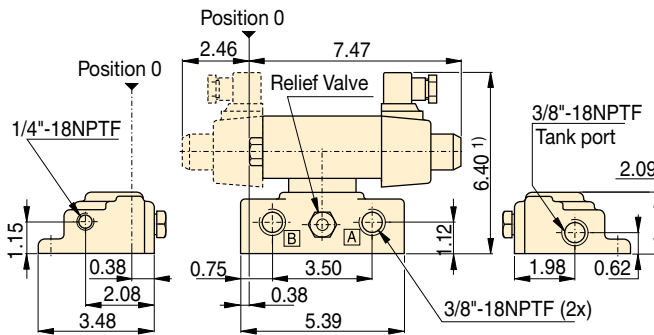
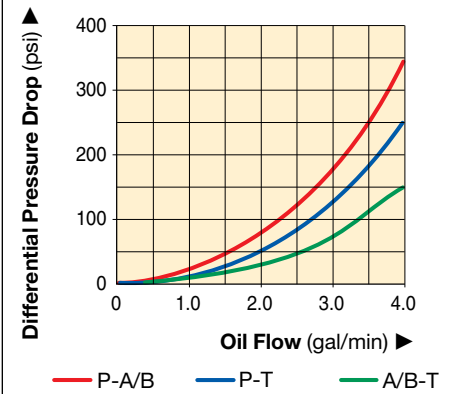

Modular Valve Pump Mounted ¹⁾ add 1.85 inch for each Accessory Valve

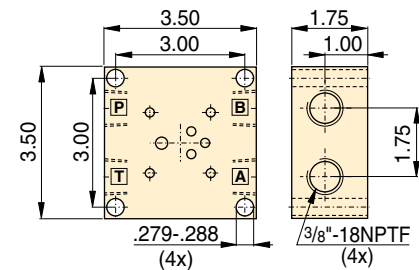

Modular Valve Remote Mount Manifold

Maximum Operating Pressure (psi)	Amperage Draw			Seal Material	Valve Plug
	24 VDC	115 VAC 60 Hz	230 V 60 Hz		
0 - 10,000	N/A Inrush	3.6 A Inrush	1.8 A Inrush	Buna-N, Polyurethane	DIN 43650
	2.5 A Holding	1.0 A Holding	0.5 A Holding		

All the additional components you need to complete your high pressure hydraulic system. Engineered to work with your Enerpac cylinders, pumps and tools. All Enerpac components are designed and manufactured to the most exacting standards.

With this complete line of hydraulic hoses, couplers, fittings, manifolds, oil and gauges Enerpac has the accessories to compliment your system and ensure the efficient operation, long life, and safety of your hydraulic equipment.



Yellow Pages

For sample system set-ups and how to correctly specify your system components, please view the Enerpac **Yellow Pages**.

Page: 399











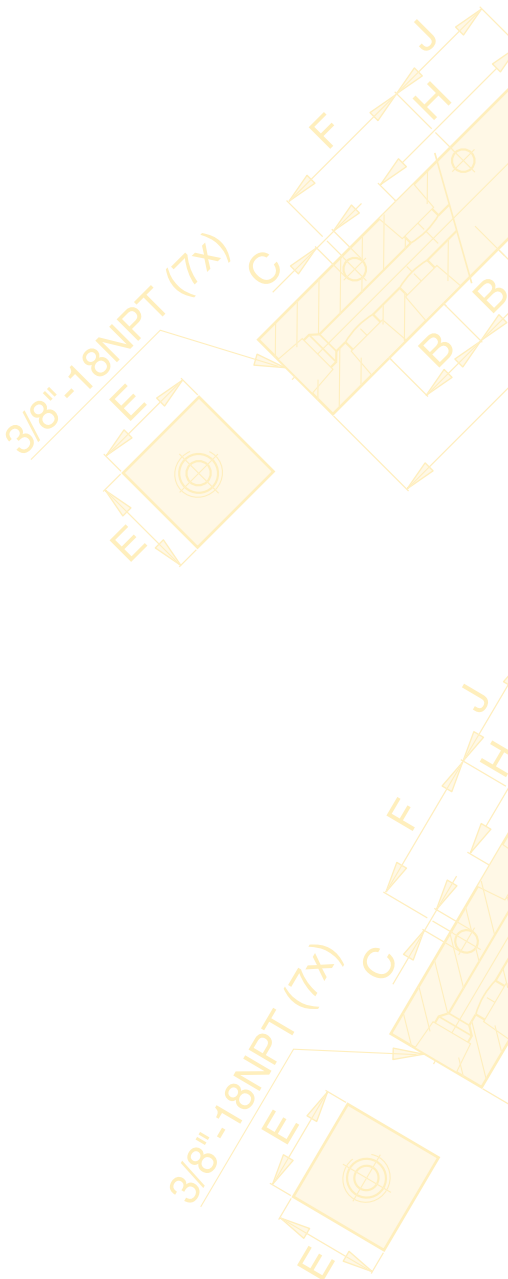





Maintain System Integrity

Use Enerpac System Components, designed to interface with Enerpac Cylinders, Pumps and Tools to ensure your system operates at peak performance.



System Components and Control Valves Section Overview



Component Type	Series		Page
Hoses	H700 H900		148 ▶
Couplers	A, C, F, Z		150 ▶
Hydraulic Oil	HF LX		152 ▶
Manifolds	A		152 ▶
Control Manifolds	AM		152 ▶
Fittings	FZ		153 ▶
Split Flow Pump Manifolds	SFM		154 ▶
Hydraulic Force & Pressure Gauges	GF GP		156 ▶
Hydraulic Pressure Gauges	G, H		158 ▶
Test System Gauges	T		160 ▶
Digital Gauges	DGR		161 ▶
Gauge Adaptor Assembly	GA45		162 ▶
Gauge Accessories	GA NV V		163 ▶
Flow and Pressure Control Valves	V		164 ▶

▼ Shown from top to bottom: HC7206, HC7210, HC9206



Emphasize Safety and Quality



To ensure the integrity of your system, specify only Enerpac hydraulic hoses.

WARNING !

- Do not exceed 10,000 psi maximum pressure.
- Do not handle hoses while under pressure.

More safety instructions in our “Yellow Pages”.

Page: 400

Vinyl strain relief guard on both ends of hose to improve life and durability on all models.

Thermo-plastic Hoses (700-Series)

- For demanding applications, featuring a 4:1 design factor
- Maximum working pressure of 10,000 psi
- Two layers of steel wire braids
- Outside jacket is polyurethane, to provide maximum abrasion resistance
- Exhibits low volumetric expansion under pressure to enhance overall system efficiency

Heavy-duty Rubber Hoses (900-Series)

- The most complete offering: 35 models up to 50 feet in length
- Rubber coated with two layers of steel wire braids
- Designed to comply with Material Handling Institute IJ100 hose specification
- Flexible, with little “memory”, is the best choice for long hose runs



◀ To prevent back pressure and to increase cylinder retraction speed, when using long hoses, the Enerpac HC7300 range of hoses with increased internal diameter is the best choice.

▼ Hose End Couplings

1/4" NPTF	
3/8" NPTF	
A604	
A630	
AH604	
AH630	
C604	
CH604	

High Pressure Hydraulic Hoses



Hose Oil Capacity

When using long hose lengths, it is sometimes necessary to fill the pump reservoir after filling the hoses. To determine the hose oil capacity, use the following:

For 0.25" internal diameter hoses:
Capacity (in³) = .5892 x Length (ft)

For 0.38" internal diameter hoses:
Capacity (in³) = 1.3608 x Length (ft)

H700 H900 Series



Inside Diameter:

0.25 and 0.38 inch

Length:

2 - 50 feet

Maximum Operating Pressure:

10,000 psi

Internal Dia. (in)	Hose End Assemblies and Couplers*		Hose Length (ft)	700-Series Thermo-plastic		900-Series Heavy-duty Rubber			
	End one	End two		Model Number	Wt. (lbs)	Model Number	Wt. (lbs)		
0.25	1/4" NPTF	1/4" NPTF	6	-		H9206Q	2.6		
		3/8" NPTF	6	-		H9206S	2.6		
		A630	6	HB7206QB	2.4	HB9206QB	3.1		
		AH630	6	-		HB9206Q	2.9		
		CH604	6	HC7206Q	2.3	HC9206Q	3.0		
	3/8" NPTF			2	H7202	1.2	H9202	1.6	
				3	H7203	1.5	H9203	1.9	
				6	H7206	2.0	H9206	2.6	
				10	H7210	3.0	H9210	3.9	
				20	H7220	6.2	H9220	8.0	
				30	H7230	10.0	H9230	13.0	
				50	H7250	15.4	H9250	22.0	
			A604				-		-
				6	HA7206B	2.5	HA9206B	3.2	
				10	-		HA9210B	4.5	
		AH604					-		
					3	-		HA9203	2.1
				6	HA7206	2.2	HA9206	2.9	
	AH630		10	HA7210	3.2	HA9210	4.2		
			6	HB7206	2.2	HB9206	2.9		
		C604		3	HC7203B	2.2	HC9203B	2.9	
			6	HC7206B	2.8	HC9206B	3.7		
			10	HC7210B	3.9	HC9210B	5.0		
	CH604		3	HC7203	1.7	HC9203	2.2		
			6	HC7206	2.3	HC9206	3.0		
			10	HC7210	3.3	HC9210	4.3		
			20	HC7220	6.4	HC9220	8.3		
	CH604	CH604	6	HC7206C	2.4	HC9206C	3.1		
50			HC7250C	15.4	HC9250C	20.0			
0.38	3/8" NPTF		6	H7306	3.5	H9306	4.6		
			10	H7310	5.4	H9310	7.0		
			20	H7320	10.0	H9320	13.0		
			30	H7330	16.2	H9330	21.0		
			50	H7350	15.2	H9350	33.0		
	CH604		6	HC7306	3.4	HC9306	4.9		
			8	-		HC9308	6.2		
			10	HC7310	5.6	HC9310	7.3		

* For technical information on couplers see next page.



GA45GC Gauge Adaptor

Protect yourself from system overloading by simply ordering one part number for a pre-assembled gauge, adaptor block and coupler.

Page: 162



Torque Wrenches Hoses

Use Enerpac 3.5:1 twin safety hoses with double-acting wrenches to ensure the integrity of your hydraulic system. See Selection Matrix.

Page: 303



Fittings

For additional fittings see the fitting page of the System Components section.

Page: 153



Premium Hydraulic Oil

Use only genuine Enerpac hydraulic oil. The wrong oil can destroy seals and pump.

Page: 152

▼ Shown: FH604, FR400, A630 disassembled, C604, AH604, AR400



3/8" High Flow Couplers

- Standard equipment on most Enerpac cylinders
- Recommended for use on all Enerpac pumps and cylinders where space and porting permits
- Include "2-in-1" dust cap for use on male and female coupler halves

3/8" High Flow "Flush-face" Couplers

- Featuring "Push-to-connect" operation, to guarantee good connection every time
- Flush-face, zero-leak operation for minimal spillage
- HTMA* recognized for safety and performance

3/8" Regular Spee-D-Coupler®

- For medium-duty applications; for use with hand pumps
- Includes female steel dust cap

1/4" Regular Coupler

- For use with small cylinders and hand pumps
- Includes female steel dust cap

1/4" Spin-on Torque Wrench Couplers

- For use with 10,000 psi S-, W-, RSL-, DSX- and HMT-Series torque wrenches, THQ-Series hoses and 10,000 psi torque wrench pumps

* Hydraulic Tool Manufacturers Association

Quick Connection of Hydraulic Lines



Thread Sealer
To seal NPTF threads use one of the new anaerobic thread sealers or Teflon® paste. When using Teflon® tape, apply the tape one thread back from the end of a fitting to prevent it from entering the hydraulic system.



WARNING!
Couplers should be pressurized only when completely connected, and should not be coupled or uncoupled when pressurized.
More safety instructions in our "Yellow Pages".
Page: 400



Torque Wrench Couplers
S-, W-, RSL-, DSX- and HMT-Series Torque Wrenches require 1/4" spin-on couplers and THQ hoses.
Page: 239

▼ With the use of Enerpac High Flow Couplers, hoses are easily installed for multiple hydraulic line connections in this 34 points PLC-controlled lifting system.



Hydraulic Couplers



CT604 Safety Tool

Use the Enerpac CT604 to relieve hydraulic back pressure by safely bleeding the hydraulic coupler. Minimize injuries from projectile parts and under-skin hydraulic fluid injections by

eliminating unsafe coupler bleeding practices. The CT604 is Enerpac-engineering safe for use at 10,000 psi (700 bar).

NOTE: C-Series only.

A, C, F, T Series



Maximum Flow Capacity:

462 - 2,500 in³/min.

Thread:

1/4" and 3/8" NPTF

Maximum Operating Pressure:

10,000 psi

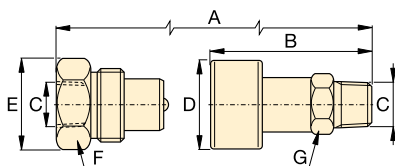

C604

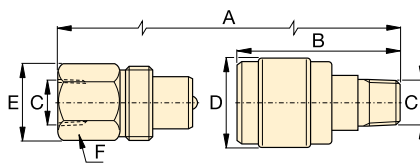

A604
A630

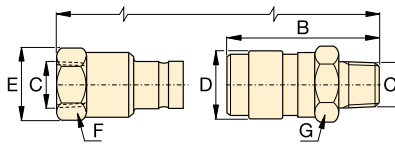

F604

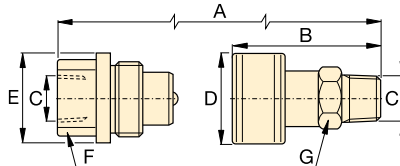

T630



Metal Dust Caps

Steel dust caps are available for the C604 series couplers. Order model number: **CD411M** for female half **CD415M** for male half

Maximum Flow Capacity (in ³ /min)	Coupler Type	Model Numbers			Dimensions (in)							Dust Cap(s)
		Complete Set	Female Half	Male Half	A*	B	C	D	E	F	G	
2,100	10,000 psi High Flow Coupler	C604	CR400	CH604	3.26	2.87	3/8" NPTF	1.38	1.38	1.25	1.00	(2x) CD411 Included
2,500	10,000 psi Flush-face coupler	F604	FR400	FH604	4.36	2.85	3/8" NPTF	1.23	1.23	1.06	1.12	-
462	10,000 psi Regular Spee-D-Coupler®	A604	AR400	AH604	3.09	2.53	3/8" NPTF	1.12	0.94	0.94	0.73	Z410 female only Included
462	10,000 psi Regular Coupler	A630	AR630	AH630	2.61	1.72	1/4" NPTF	0.87	0.81	0.75	0.57	Z640 female only Included
695	10,000 psi Spin-on Coupler	T630	TR630	TH630	2.87	2.36	1/4" NPTF	1.14	1.14	0.74	0.82	-

* Value A is total length when male and female halves are connected.

▼ Shown top to bottom: HF101, HF100, HF102, LX101, A65, and FZ1055



Hydraulic Oil

Contents	Model Number	High viscosity index ensures maximum lubricity over a wide range of operation temperatures.
1 Quart	HF100	
1 Gallon	HF101	
5 Gallons*	HF102	
55 Gallons	HF104	
1 Gallon**	LX101	

* Packed in two 2½ gallon cans.

** Hand pump oil.

▼ Oil Specifications Chart

	HF Oil	LX Oil
ISO Viscosity Grade	32	15
API Gravity, ASTM D1298	32	34
Viscosity, ASTM D445		
SUS @ 212° F	43.7	38
SUS @ 104° F	151	77.5
Viscosity Index, ASTM D2270	95	100
Pour Point, °F, ASTM D97	-36.5	-47.5
Flash Point, °F, ASTM D92	375	370
Color	Blue	Yellow

NOTE: SAE grades do not apply to hydraulic oil.

HF Oil

- Specially formulated for power pumps
 - maximum volumetric efficiency
 - maximum heat transfer
 - prevents cavitation
 - anti-sludge, anti-rust, anti-foam additives
- Maximum film protective lubricity
 - anti-oxidation additives

LX Hand Pump Oil

- Specially formulated for hand pumps
 - anti-sludge, anti-rust additives
- Reduced handle effort over HF blue oil
 - good low temperature performance
- Not for use in power pumps

Manifolds

Description		Model No.	Dimensions (in)
7" Long Manifold with 7 female ports.		A64	
14" Long Manifold that allows direct mounting of control valves to the manifold. 7 female ports.		A65	
6-Port Hexagon Manifold Plugs furnished for all ports ⅜"-18 NPTF.		A66	
Premounted Manifold Functions as split-flow valve to control 2 to 4 single-acting cylinders simultaneously. All ports ⅜"-18 NPTF.		AM21 AM41	
4-Way Single- and Double-Acting Manifold Assemblies with female couplers on all ports allowing the manifold to be quickly connected to up to 4 cylinders.		AMGC41 AMGC42	

Hydraulic Oil, Manifolds and Fittings



3/8" Swivel Connector

360° swivel coupler for optimal orientation of the hydraulic connection on cylinders, pumps and hoses. Order Model No. **XSC1**.

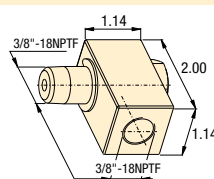

**A, AM
FZ,
BFZ,
HF, LX
Series**



10,000 psi Fittings		Model Number	Dimensions (in)				Diagram	
			A	B	C	D		
Street Elbow			FZ1616	0.94	1.30	3/8" -18 NPTF	3/8" -18 NPTF	
From: 3/8" -NPTF Male	To: 3/8" -NPTF Female							
Reducing Connector			FZ1615	1.13	1.00	3/8" -18 NPTF	1/4" -18 NPTF	
From: 3/8" -NPTF Female	To: 1/4" -NPTF Female							
			FZ1625	1.38	1.25	1/2" -14 NPTF	3/8" -18 NPTF	
From: 1/2" -NPTF Female	To: 3/8" -NPTF Female							
Hexagon Nipple			FZ1608	1.50	0.63	1/4" -18 NPTF	1/4" -18 NPTF	
From: 1/4" -NPTF	To: 1/4" -NPTF							
From: 3/8" -NPTF	To: 3/8" -NPTF							
From: 3/8" -NPTF	To: 3/8" -NPTF							
Coupling			FZ1614	1.14	1.00	3/8" -18 NPTF	3/8" -18 NPTF	
From: 3/8" -NPTF	To: 3/8" -NPTF							
			FZ1605	1.14	0.75	1/4" -18 NPTF	1/4" -18 NPTF	
From: 1/4" -NPTF	To: 1/4" -NPTF							
Cross			FZ1613	1.77	1.00	3/8" -18 NPTF	-	
From: 3/8" -NPTF Female	To: 3/8" -NPTF Female							
Street Tee			FZ1612	1.77	1.00	3/8" -18 NPTF	-	
From: 3/8" -NPTF	To: 3/8" -NPTF							
			FZ1637	1.77	0.94	1/4" -18 NPTF	-	
From: 1/4" -NPTF	To: 1/4" -NPTF							
Street Tee			BFZ16312	2.20	1.02	3/8" -18 NPTF	3/8" -18 NPTF	
From: 3/8" -NPTF Female	To: 3/8" -NPTF Male							
Elbow			FZ1610	1.38	0.88	3/8" -18 NPTF	-	
From: 3/8" -NPTF	To: 3/8" -NPTF							
			FZ1638	1.41	0.94	1/4" -18 NPTF	-	
From: 1/4" -NPTF	To: 1/4" -NPTF							
Reducer			FZ1630	0.75	0.75	1/4" -18 NPTF	3/8" -18 NPTF	
From: 3/8" -NPTF	To: 1/4" -NPTF							
From: 1/4" -NPTF	To: 1/2" -NPTF							
			BFZ1630	1.10	0.86	1/4" -18 NPTF	1/2" -14 NPTF	
From: 3/8" -NPTF	To: G1/4"							
Adaptor			BFZ16411	1.37	0.75	1/4" -18 NPTF	G1/4"	
From: G1/4"	To: 1/4" -NPTF							
From: G1/4"	To: 1/8" -NPTF							
From: G3/8"	To: 1/4" -NPTF							
			BFZ16323	1.69	0.94	1/4" -18 NPTF	G3/8"	
From: G3/8"	To: 3/8" -NPTF							
From: G3/8"	To: 3/8" -NPTF							
Adaptor			FZ1055	1.75	0.94	1/4" -18 NPTF	3/8" -18 NPTF	
From: 1/4" -18 NPTF	To: 3/8" -18 NPTF							
From: 1/2" -14 NPTF	To: 1/4" -18 NPTF							
			FZ1633	1.18	0.75	1/2" -27 NPTF	1/4" -18 NPTF	
From: 1/2" -14 NPTF	To: 3/8" -18 NPTF							
			FZ1634	1.75	1.13	3/8" -18 NPTF	1/2" -18 NPTF	
From: 1/2" -14 NPTF	To: 3/8" -18 NPTF							
Swivel Fitting			FZ1660	1.59	0.88	3/8" -18 NPTF	3/8" -18 NPTF	
From: 3/8" -NPTF Male	To: 3/8" -NPTF Female							

▼ Shown from left to right: SFM41, SFM42 Split-Flow Manifolds



- **Split-Flow Manifolds improve safety, precision and control in lifting and lowering operations**
- **Pressure gauge, flow control valve in each outlet port; CR400 couplers installed in each inlet and outlet port**
- **Regulates both advance and retract speeds: lifting and lowering**
- **1 inlet, 4 outlets. Maximum of 4 cylinders per manifold: SFM41 for single-acting cylinders, SFM42 for double-acting cylinders**
- **Minimum pump oil flow: 85 in³/min to deliver 9.1-15 in³/min per cylinder**
- **Maximum difference among outlets: 10% of the stroke (in 6 inch stroke)**
- **More cylinders can be controlled simultaneously by connecting several SFM-models parallel**



Improved safety on basic simultaneous lifting applications



Pressure Gauges G2535L

Glycerin filled pressure gauges are installed in each outlet pressure line to monitor the pressure of each cylinder.

Page: 162



Optimum Performance

Minimum pump oil flow must be 85 in³/min to deliver 9.1-15 in³/min per cylinder. Enerpac recommends to use

Z-Class electric or gasoline pumps from the ZE5 and ZG-Series.



SFP-Series, Split-Flow Pumps

When a higher accuracy is required across cylinder strokes in a multi-point

lifting or lowering application Enerpac recommends using the SFP-Series Split-Flow Pumps.

Page: 132



Contact Enerpac!

Contact the Enerpac office nearest to you for advice and technical assistance in the layout of your ideal Lifting System or visit us at: www.enerpac.com. Or ask Enerpac for assistance: enerpac.com/contact-us

◀ *To repair the foundation, silos needed to be lifted, levelled and structurally supported. Powered by a ZE5-Series electric pump the split-flow manifold used to operate multiple hydraulic cylinders.*



Split-Flow Manifolds

The SFM-Series offer an economical solution for basic multi-point simultaneous lifting applications and enables a single operator to control a maximum of 4 lifting points from one manifold.

The Split-Flow Manifolds are equipped with pressure compensated flow control valves, to preset and limit advance and retract speed of each cylinder, allowing to move up to 4 cylinders simultaneously.

The SFM-Series provide more lifting and lowering control compared to AM-Series Control Manifolds. See flow control valve adjustments table below.

Minimum pump oil flow must be 85 in³/min (ZE5-Series pumps) to deliver 9.1-15 in³/min per cylinder. Several SFM-models can be connected parallel to the same pump to allow simultaneous operation of 8, 12 or 16 cylinders.

Higher flow pumps are required to achieve faster advance speeds. A 20% higher oil flow must be considered for a proper speed compensation.

Example : when using 4 cylinders: if oil flow of 28 in³/min is required per cylinder, the pump oil flow must be: $4 \times 28 = 112 + 20\% = 134 \text{ in}^3/\text{min}$.

The maximum stroke deviation between the cylinders can reach up to 10% (in 6 inch stroke) depending on the cylinder pressure.

Oil flow adjustment is also possible during cylinder operation by fine tuning using the flow control valves.

All cylinders connected to the SFM-manifold must have the same capacity (effective area). Both advance and retract speed are limited by the same valves. Use hoses of the same lengths to improve the accuracy of the hydraulic system. Improved precision when difference of pressures among the cylinders is within 2900 psi.

SFM Series



Inlet Connection:

1x Power Pump

Outlet Connections:

Max. 4 Cylinders

Minimum Pump Flow Required:

85 in³/min.

Maximum Operating Pressure:

10,000 psi



Load Holding

Use **V66 Check Valves** for load holding applications with single-acting cylinders.

Page: 165

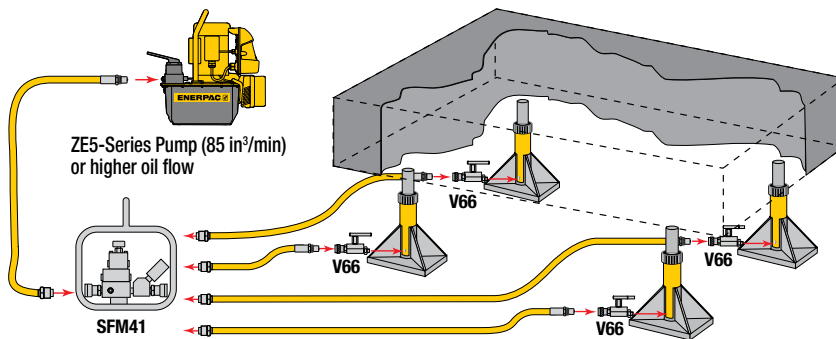

Hoses

Enerpac offers a complete line of high-quality hydraulic hoses. To ensure the integrity of your system, specify only genuine Enerpac hydraulic hoses. Enerpac recommends using hoses of the same lengths between the SFM and cylinders to improve system accuracy.

Page: 148

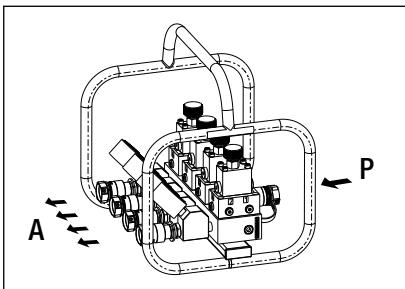

SFM41

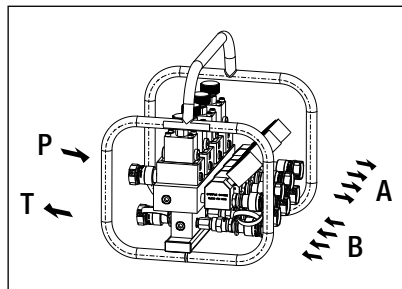

SFM42

▼ SPLIT-FLOW MANIFOLDS

For use with Cylinders	Model Number	Minimum Oil Flow to each Cylinder (in ³ /min)	Female Couplers Included	Dimensions L x W x H (in)	Wt. (lbs)
4x single-acting	SFM41	9.1	CR400	14.6 x 13.2 x 14.8	53
4x double-acting	SFM42	9.1	CR400	14.6 x 13.2 x 14.8	66



Flow Control Valves

The Split-Flow Manifold has pressure compensated flow control valves installed in each outlet line. The oil flow from the SFM-Manifold to each cylinder can be adjusted by turning the knob on the valve.

Flow Control Valve Adjustments

Number of Knob Turns	Oil Flow (in ³ /min)	Number of Knob Turns	Oil Flow (in ³ /min)
1/2	9.1	3	115.9
1	27.4	3 1/2	219.6
1 1/2	45.8	4	341.6
2	54.9	4 1/2	506.3
2 1/2	79.3	Open	628.3

▼ Shown: GF230P, GF835P, GP10S



- GF-Series gauges are calibrated with dual scale reading for pressure and force
- Excellent readability; 4-inch diameter gauge face
- Fast, easy installation
- GF-Series gauges are glycerin filled
- Stainless steel gauge cases for corrosion resistance
- GP-Series gauges are calibrated with dual scale reading for psi and bar

▼ A GP10S gauge is used on this press to check the hydraulic pressure required to bend a steel plate.



Visual References for System Pressure and Force



Auto-Damper Valve V10

For automatic control of gauge fluctuations, the **V10** Auto-Damper Valve controls the movement of the gauge needle by restricting oil flow in and out of the gauge. No adjustments needed.

Page: 164



Snubber Valve V91

Infinitely adjustable for metering oil out of a gauge. The **V91** Snubber Valve is also suitable as a shut-off valve to protect the gauge during high cycle applications.

Page: 163

Used With

	All 10-ton cylinders
	All 15-ton cylinders
	All 5-ton RC, RSM cylinders
	All 10-ton RC, RCS, RSM cylinders
	All 25-ton RC cylinders
	All 50-ton RC, RR cylinders
	12-ton RCH-Series
	RCH, RRH20, 30 and 60-ton
	RCS201, 302
	RCS502, 1002
	25, 30, 50-ton RC, RCS, RSM, RR
	75 and 95-ton RC, RR cylinders
	150 and 200-ton RR cylinders
	10-ton presses
	25-ton presses
	50-ton presses
	100-ton presses
	150-200 ton presses

Hydraulic Force and Pressure Gauges



Load Gauges

To measure external load supported by a cylinder or jack. For pressing parts together under pre-determined loads, weighing, testing, etc.

Pressure Gauges

To measure the input pressure into cylinders, jacks or high pressure systems. Also for all testing applications.

GP-Series gauges are dry gauges.
GF-Series gauges are glycerin filled.

Force Gauges

To measure external load supported by a cylinder or jack in tons. For pressing parts together under pre-determined loads, weighing, testing, etc.

GF GP Series



Pressure Range:
0 - 15,000 psi

Face Diameter:
4 inches

Accuracy, % of full scale:
± 1%

All Models

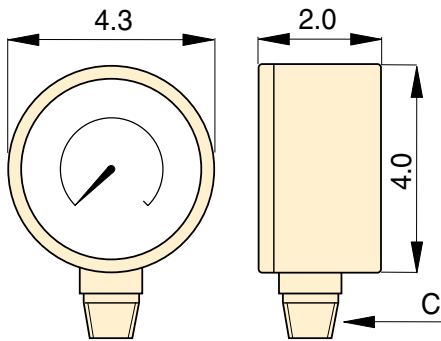



Maximum Indicator Pointer

Indicator retains peak readings of pressure or force generated by the system.

Order model number:
H4000G.

Can easily be installed on GP-Series dry gauges.

Gauge Type and Calibration					Units per Division	Model Number*	Thread C	Gauge Adaptor		
										
psi	bar	psi	lbs	tons			(in)	GA1	GA2	GA3
0-10,000	0-700	-	-	-	100 psi, 10 bar	GP10S	1/2 NPTF	●	●	
0-15,000	0-1000	-	-	-	200 psi, 10 bar	GP15S	1/2 NPTF	●	●	
-	-	0-10,000	0-10,000	0-5	100 psi, 100 lbs, 0.1 ton	GF5P	1/2 NPTF	●	●	
-	-	0-10,000	0-22,200	0-11	100 psi, 200 lbs, 0.2 ton	GF10P	1/2 NPTF	●	●	
-	-	0-10,000	0-51,500	0-25.5	100 psi, 500 lbs, 0.5 ton	GF20P	1/2 NPTF	●	●	
-	-	0-10,000	0-110,000	0-55	100 psi, 1000 lbs, 1 ton	GF50P	1/2 NPTF	●	●	
-	-	0-10,000	0-27,000	0-13.5	100 psi, 200 lbs, 0.25 ton	GF120P	1/2 NPTF	●	●	
-	-	0-10,000	-	0-23.5/36/65	100 psi, 0.5/0.5/1 ton	GF813P	1/4 NPTF			●
-	-	0-10,000	-	0-22/32	100 psi, 0.5/0.5 ton	GF230P	1/2 NPTF	●	●	
-	-	0-10,000	-	0-50/100	100 psi, 1/1 ton	GF510P	1/2 NPTF	●	●	
-	-	0-10,000	-	0-25.5/32.5/55	100 psi, 0.5/0.5/0.5 ton	GF835P	1/4 NPTF			●
-	-	0-10,000	-	0-79/103	100 psi, 1/1 ton	GF871P	1/4 NPTF			●
-	-	0-10,000	-	0-150/200	100 psi, 5/5 ton	GF200P	1/4 NPTF			●
-	-	0-10,000	0-22,200	0-11	100 psi, 200 lbs, 0.2 ton	GF10P	1/2 NPTF	●	●	
-	-	0-10,000	0-51,500	0-25.5	100 psi, 500 lbs, 0.5 ton	GF20P	1/2 NPTF	●	●	
-	-	0-10,000	0-11,000	0-55	100 psi, 1000 lbs, 1 ton	GF50P	1/2 NPTF	●	●	
-	-	0-10,000	-	0-79/103	100 psi, 1/1 ton	GF871P	1/4 NPTF			●
-	-	0-10,000	-	0-150/200	100 psi, 5/5 ton	GF200P	1/4 NPTF			●

* Metric scale Force Gauges are available by changing the "P" suffix to "B".

▼ Shown: H4049L, G2534R, G4089L, G2535L, G4040L



Visual References for System Pressure



GA45GC Gauge Adaptor Assembly

45° angled gauge adaptor improves safety.

Page: 162



Gauge Adaptor

For easy gauge installation into almost any system, Enerpac offers a complete line of gauge adaptors.

Page: 153



Snubber Valve V91

Infinitely adjustable for metering oil out of a gauge. The V91 Snubber Valve is also suitable as a shut-off valve to protect the gauge during high-cycle applications.

Page: 163

Glycerin Filled (G-Series)

- Calibrated in dual scale reading in psi and bar
- All pressure sensing parts sealed and dampened by glycerin for long life
- Includes safety blow-out disk and pressure equalizing membrane
- Gauge snubbers or needle valves recommended for high-cycle applications

High-Cycle Dry Gauges (H-Series)

- Calibrated in dual scale reading in psi and bar
- Ideal for use in many applications, specifically for high cycle and harsh environments
- Gauge snubbers or needle valves recommended to shut off gauge when not in use



◀ When lifting or pressing, always use a gauge. A gauge is your "window" to the system—it lets you see what's going on.

Hydraulic Pressure Gauges



CAUTION! When lifting or pressing, always use a gauge.

Do not override factory setting of relief valves. Always use a gauge to check system pressure. A gauge is your "window" to the system. It lets you see what's going on.

See our Safety Instructions.

Page: 400

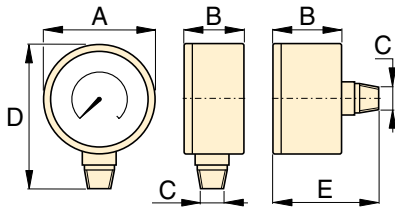

Dimensions (in)						
Face Diam.	Connection	A	B	C	D	E
2.5	Lower Mount	2.50	1.46	¼" NPTF	3.31	–
2.5	Center Rear	2.50	1.46	¼" NPTF	–	2.48
4.0	Lower Mount	4.0	1.15	¼" NPTF	4.80	–
4.0	Lower Mount	4.0	1.93	½" NPTF	5.38	–

Note: dimensions for reference only.

**G
H
Series**



Pressure Range:
0 - 15,000 psi

Face Diameter:
2.5 - 4 inches

Accuracy, % of full scale:
±1% and 1½%



Maximum Indicator Pointer

Indicator retains peak readings of pressure or force generated by the system.

Order model number: **H4000G**.

Note: For use on H-Series gauges only.

▼ SELECTION CHART

Gauge Series	Pressure Range		Model Number				Major Graduation		Minor Graduation		Major Graduation		Minor Graduation	
			Face ø 2.5" ¼ NPTF Lower Mount	Face ø 2.5" ¼ NPTF Center Rear	Face ø 4" ¼ NPTF Lower Mount	Face ø 4" ½ NPTF Lower Mount								
			(psi)	(bar)	Accuracy ±1½%	Accuracy ±1½%	Accuracy ±1%	Accuracy ±1%	(psi)				(bar)	
		(2.5")	(4")	(2.5")	(4")	(2.5")	(4")	(2.5")	(4")	(2.5")	(4")	(2.5")	(4")	
G -Series	0-100	0-7	G2509L	–	–	–	10	–	2	–	1	–	0,01	–
	0-160	0-11	G2510L	–	–	–	10	–	2	–	1	–	0,02	–
	0-200	0-14	G2511L	–	–	–	50	–	5	–	1	–	0,02	–
	0-300	0-20	G2512L	–	–	–	50	–	5	–	5	–	0,50	–
	0-600	0-40	G2513L	–	–	–	100	–	10	–	10	–	1	–
	0-1,000	0-70	G2514L	G2531R	–	–	100	–	20	–	10	–	1	–
	0-2,000	0-140	G2515L	–	–	–	500	–	50	–	10	–	2	–
	0-3,000	0-200	G2516L	–	–	–	500	–	50	–	50	–	5	–
	0-6,000	0-400	G2517L	G2534R	–	–	1000	–	100	–	100	–	10	–
	0-10,000	0-700	G2535L	G2537R	G4088L	G4039L	2000	1000	200	100	100	100	10	10
0-15,000	0-1000	G2536L	G2538R	G4089L	G4040L	3000	3000	200	200	100	100	20	20	
H-Series	0-10,000	0-700	–	–	H4049L	H4071L	–	1000	–	100	–	100	–	10

▼ Gauge shown: **T6003L**



T Series

Pressure Range:
0 - 50,000 psi

Face Diameter:
6.4 inches

Accuracy, % of full scale:
± 1/2% and ± 1 1/2%



Cone Mount Gauge Adaptor

Contains fittings to connect 1/4" cone fitting gauge to 3/8" cone system.

Kit includes **43-301** tee, **43-704** gauge adaptor and **45-116** tubing.

Order model number: **83-011**.

Page: 95



Cone Mount Gauge Connector

For connecting gauges with 1/4" cone fitting directly to model number **11-100** or **11-400** pump. May be used with other 1/4" cone systems.

Order model number: **43-704**

Page: 95

- Calibrated for dual scale reading in psi and bar
- All gauges have spring-loaded backs with rubber blow-out plugs to protect case assembly in case of over-pressurization
- 40,000 and 50,000 psi models include flange mounting
- 1/2" NPTF versions are made of high-strength alloy steel
- 0.25" cone models are made of 316 stainless steel, with 403 stainless steel on 40,000 and 50,000 psi models
- Integral maximum indicator pointer standard on all gauges

▼ An Enerpac P2282 hand pump equipped with a T6011L test system gauge is used for proof pressure testing of hydraulic valves.

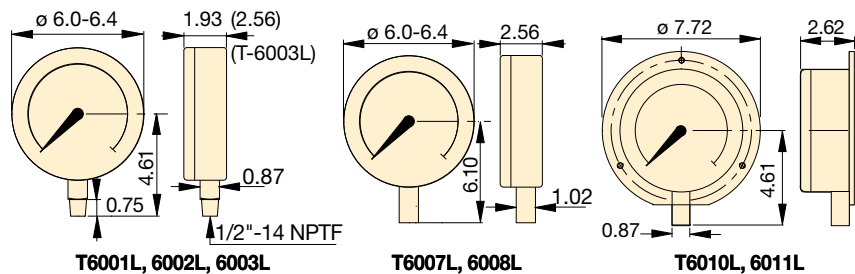

Pressure Range (psi)	Pressure Range (bar)	Model Number		Number Intervals (psi)	Graduation Intervals (psi)	Number Intervals (bar)	Graduation Intervals (bar)
		Alloy Steel 1/2" NPTF	Stainless Steel 0.25" Cone				
0-1,000*	0-70	T6001L	-	100	10	10	1
0-5,000*	0-350	T6002L	-	500	50	50	5
0-10,000*	0-700	T6003L	T6007L	1,000	100	100	10
0-20,000*	0-1400	-	T6008L	1,000	100	200	20
0-40,000**	0-2800	-	T6010L	5,000	200	500	20
0-50,000**	0-3500	-	T6011L	5,000	500	500	50

* Accuracy: $\pm 1/2\%$

** Accuracy: $\pm 1 1/2\%$

Digital, Hydraulic Pressure Gauges

▼ Gauge shown: **DGR2**



DGR Series

Pressure Range:
0 - 20,000 psi

Voltage:
3 VDC (battery)

Accuracy, % of full scale:
± 0.25%

- Rated for system pressure up to 20,000 psi
- Displays in multiple units: psi, bar, mPA, kg/cm² (user selectable)
- Zero reset – ensures that gauge reads actual system pressure
- Batteries included, condition indicator on read-out
- IP65 rated case design
- Shut off selectable – menu driven
- UL listed, CE and RoHS compliant



Back-lit Readout

Back-lit readout allows easy reading in less than ideal lighting.



Gauge Adaptor

For easy gauge installation into almost any system, Enerpac offers a complete line of gauge adaptors.

Page: 163

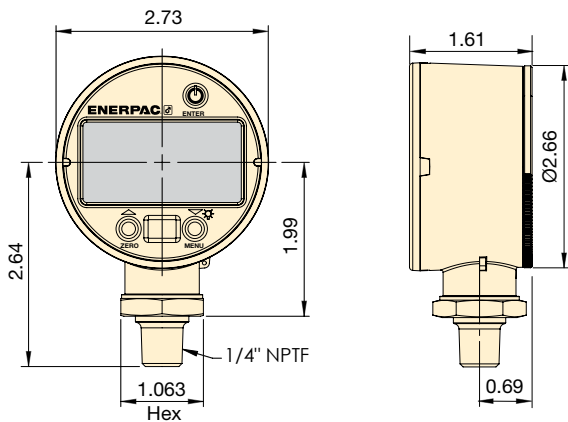

Pressure Rating (psi)		Pressure Rating (bar)		Model Number	Pressure Rating (MPa)		Pressure Rating (Kg/cm ²)	
Range	Resolution	Range	Resolution		Range	Resolution	Range	Resolution
0-20,000	1	0-1380	0.1	DGR2	0-140	0.01	0-1400	0.1

▼ Greater accuracy and easier to read: enhance your ability to monitor and control hydraulic system pressure up to 20,000 psi.



▼ Shown: GA45GC



- 45° angled gauge improves visibility
- Slim and narrow design
- Easy to fit in a broad range of systems
- Maximize controlled load movement
- Glycerin dampened gauge with dual scale
- Enerpac high-flow female coupler

GA45GC, AMGC Series

Maximum Operating Pressure:
10,000 psi

Connection 1:
3/8" NPTF Male

Connection 2:
CR400 Coupler



4-Way Manifold Assembly Complete with Gauges

Offering ease of portability and convenience with an ergonomic robust design, ready to use. Enerpac's CR400 female couplers on all ports allow the manifold to be quickly connected to up to four cylinders. Glycerin filled, 10,000 psi gauges allow operators to work safely. All protected by the robust protection frame.

Manifold Type (used for cylinders)	Model Number
4x Single-acting	AMGC41
4x Double-acting	AMGC42

Page: 154



Portable Tool Box

Portable tool box with hand pump, GA45GC gauge adaptor assembly, hose and RC, RSM, RCS-cylinder, WR5 wedgie or LW16 lifting wedge.

Page: 65

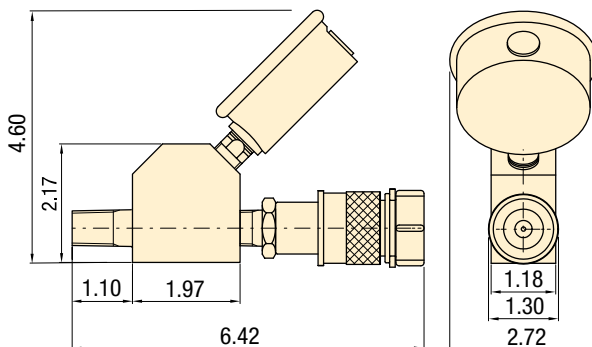

Model Number	Gauge Port	Male End	Female End	Gauge Range	
				(psi)	(bar)
GA45GC	G2535L	3/8" NPTF	CR400	0-10,000	0-700

▼ The Gauge Adaptor Assembly is the window to your system; allows easy reading of the pressure for safe operation.



▼ Shown left to right: GA3, V91, GA1, GA2, GA4, NV251, GA918







GA, NV, V Series

Operating Pressure:

10,000 psi

▼ A gauge is easily installed into your hydraulic system using a gauge adaptor.



Gauge Adaptors (GA-Series)

- For easy mounting of a pressure gauge into your system
- Male end screws into pump or cylinder port, female end accepts hose or coupler, third port is for gauge connection
- GA918 provides for swivel connection
- Simplifies gauge installation and reading

Model Number	Gauge Port (NPTF)	Male End (NPTF)	Female End (NPTF)	Dimensions (in)					
				A	B	C	D	E	F
GA1	1/2" NPTF	3/8" NPTF	3/8"	2.81	1.24	1/2" NPTF	3/8" NPTF	3/8" NPTF	1.25
GA2	1/2" NPTF	3/8" NPTF		6.10	1.38	1/2" NPTF	3/8" NPTF	3/8" NPTF	1.25
GA3	1/4" NPTF	3/8" NPTF		5.25	1.38	1/4" NPTF	3/8" NPTF	3/8" NPTF	1.25
GA4	1/2" NPTF	1/4" NPTF		4.38	1.38	1/2" NPTF	1/4" NPTF	3/8" NPTF	1.25

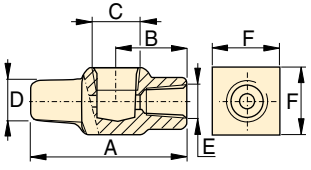

GA1

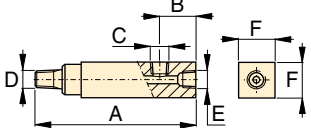

GA2, GA3, GA4





Swivel Adaptor (GA918)

- Simplifies gauge installation and reading

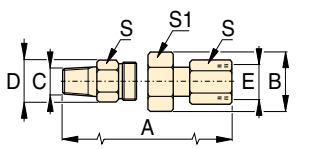
Model Number	Dimensions (in)							
	A	B	C	D	E	S	S1	
GA918	4.62	1.72	1/2" NPTF	1.30	1/2" NPTF	1.13	1.50	



Needle Valves (NV- and V-Series)

- Both NV251 and V91 provide positive shut-off
- 316 stainless steel stem, 24 threads/in.

Model Number	Orifice	Thread Size	Dimensions (in)						
			A	B	C	D	E	F	G
NV251	0.17	1/4" NPT	2.22	0.75	0.38	1.81	2.25	1.13	0.72
V91	0.19	1/2" NPT	3.50	1.44	0.63	1.25	2.50	1.25	—

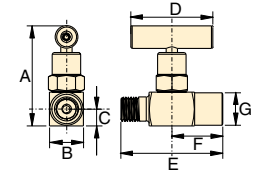

NV251

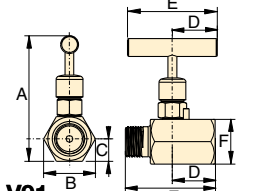

V91

▼ Shown from left to right: V152, V66, V82, V161, V42, V17



Your Hydraulic Control Solution



Valve Applications

To see these valves used in typical hydraulic circuits, please see our "Yellow Pages".

Page: 410

▼ The V152 Pressure Relief Valve limits the pressure or force developed in the hydraulic system.



- All valves are rated for 10,000 psi operating pressure
- All valves feature NPTF porting to insure against leakage at rated pressure
- All valves are painted, coated, or plated for corrosion resistance
- Viton® seals (in V66NV and V152NV) for high temperature applications, nickel-plated for maximum corrosion resistance

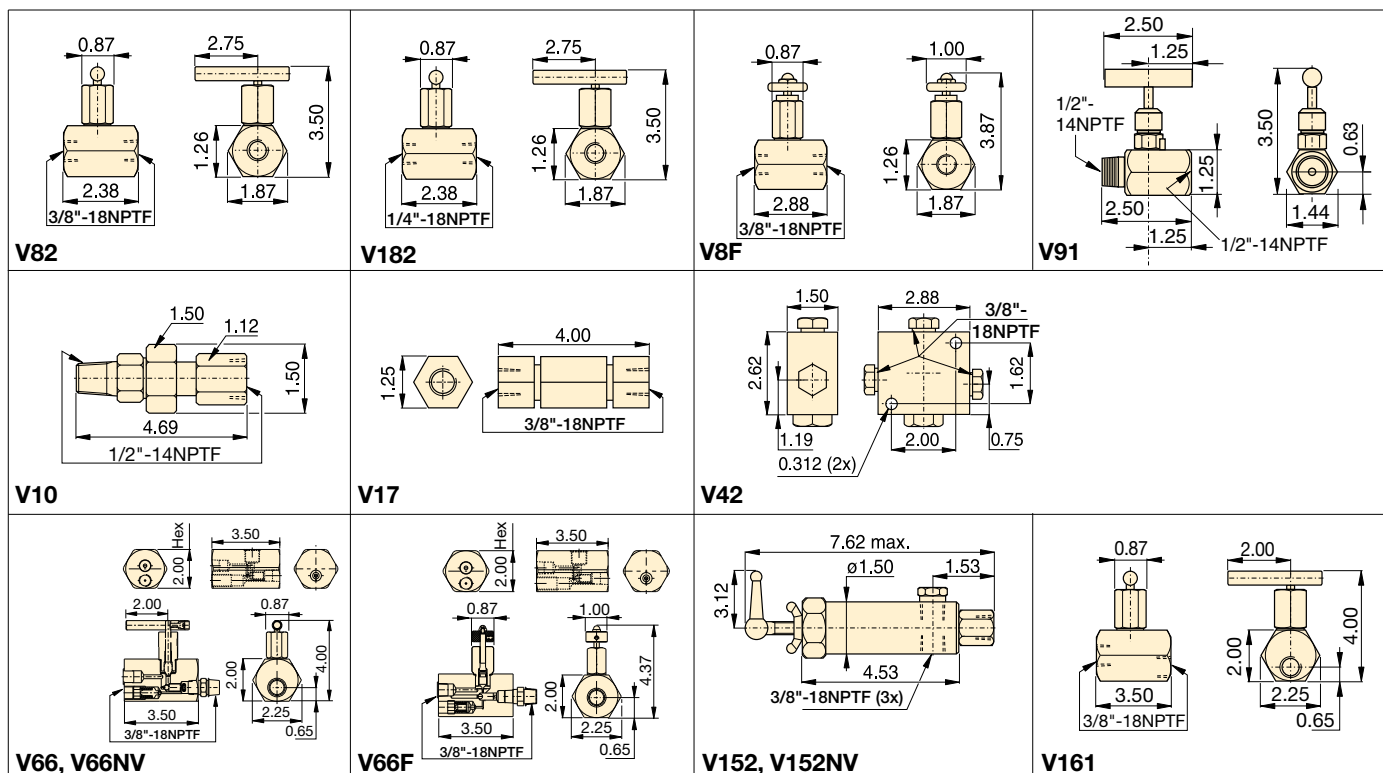

Valve Dimensions in inches.

Flow and Pressure Control Valves



Premounted Manifold

For two or four port manifold with integral flow control valves, see the manifold page of the System Components section.

Page: 152



Fittings

















For additional fittings see the fitting page of the System Components section.

Page: 153

V Series



Maximum Operating Pressure:
10,000 psi

Valve Type and Model Number	Description	Hydraulic Symbol
Needle Valve V82 V182F V8F	 <p>V82: To control cylinder speed. Can also be used as shut-off valve for temporary load holding. $\frac{3}{8}$" NPTF female ports. V182: Same as V82, but with $\frac{1}{4}$" NPTF female ports. Also suitable for gauge snubbing. V8F: Similar to V82, but with very fine metering for precise flow control. Not recommended as shut-off valve.</p>	
Snubber Valve V91	 <p>V91: Adjustable for metering oil out of a gauge to prevent snapping of gauge pointer when load or pressure is suddenly released. Also suitable as shut-off valve to protect the gauge during high cycling applications. $\frac{1}{2}$" NPTF male and female threads for use with GA1, GA2 or GA4 gauge adaptors.</p>	
Auto Damper® Valve V10	 <p>V10: To be used when gauge pressure must be monitored during high cycle applications. Creates a flow resistance when load is released suddenly. No adjustments are necessary. $\frac{1}{2}$" NPTF male and female threads for use with GA1, GA2 or GA4 gauge adaptors.</p>	
Check Valve V17	 <p>V17: Ruggedly built to resist shock and operate with low pressure drop. Closes smoothly without pounding. $\frac{3}{8}$" NPTF female ports.</p>	
Pilot Operated Check Valve V42	 <p>V42: Can be mounted at the cylinder to hold the load in case of system pressure loss. Normally used with double-acting cylinders where pilot port receives pressure from a Tee-fitting in the cylinder retract line. $\frac{3}{8}$" NPTF female ports. Pilot pressure ratio 14% (6.5:1).</p>	
Manually Operated Check Valve V66, V66NV* V66F	 <p>V66, V66NV: For load holding applications with single- and double-acting cylinders. Valves allow oil to flow back to tank when cylinder retracts. V66NV with Viton seals, nickel-plated. V66F: Similar to V66, but with very fine metering capability for precise flow control. V66F not designed for load holding applications.</p>	
Pressure Relief Valve V152 V152NV*	 <p>V152: Limits pressure developed by the pump in hydraulic circuit, thus limiting the force created by other components. Valve opens whenever preset pressure is reached. To increase pressure setting, turn handle clockwise. Includes: <ul style="list-style-type: none"> • 3 ft return line hose kit • $\pm 3\%$ repeatability • 800-10,000 psi adjustment range. </p>	
Sequence/Pressure Differential Valve V161	 <p>V161: To control oil flow to a secondary circuit. Flow is blocked until system pressure rises to the V161 setting. When this pressure level is reached, the V161 opens to allow flow to the secondary circuit. A pressure differential is always maintained between the primary and secondary circuit. Min. operating pressure: 2000 psi.</p>	

* See page 64 for more information about products for use in high temperature and extreme environment applications.

Enerpac Hydraulic Presses are available in a wide variety of standard capacities, configurations and constructions, or you can “build your own” with the easy-to-use matrix.

The IP and IPR-Series Presses are a welded construction for maximum strength and durability, and when combined with the power of high-pressure hydraulics, will provide years of safe and dependable service in your workshop.

XLP-Series Presses are a bolted construction which offer exceptional value.

Enerpac press capacities range from 10 tons to 200 tons and are available in Bench, C-Clamp, Arbor, H-Frame and Roll-Frame models.

These press features increase productivity and broaden the range of applications:

Standard on many Enerpac IP Presses, the exclusive Hydra-Lift™ offers effortless adjustment to the press daylight by use of a hydraulic lift.



Easy horizontal cylinder position is achieved with the unique “roller-head” cylinder mounting block, standard on most Enerpac IP Presses.



Optional “V-blocks” for positioning of complex parts are designed with high-strength steel for long life.

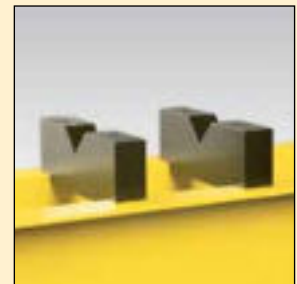

Press Section Overview

Available in capacities from 10 to 200 ton, each Enerpac press consists of three basic high-quality components: a press frame, a power source and a cylinder.

Press Frame

Press frames include features like horizontally adjustable cylinders and vertically adjustable bolsters for ease of use and optimal positioning of the workpiece.

Power Source









Depending on the production requirements, Enerpac presses can be powered by manual, air hydraulic and electric pumps.

Cylinder

Depending on the application, double-acting cylinders offer increased efficiency. Check out the Selection Charts for the press best suited for your needs.

Gauge

All Workshop presses and Roll-Frame Presses feature an easy to monitor pressure/force gauge for increased safety.

Capacity (tons)	Press Type and Functions	Series		Page
10-200	H-Frame Presses	IP		168 ▶
50-200	Roll Frame Presses	IPR		172 ▶
5-20	C-Clamp Presses	A		174 ▶
10-30	Arbor Presses	A		175 ▶
10-200	Press Accessories Press Speed Chart			176 ▶
10-200	Custom Built Presses	IP		177 ▶
10-75	Workshop Bench Presses Workshop H-Frame Presses	VLP XLP		178 ▶
5 1-100	Tension Meter Load Cells	TM LH		180 ▶
	Custom Hydraulic Presses			181 ▶

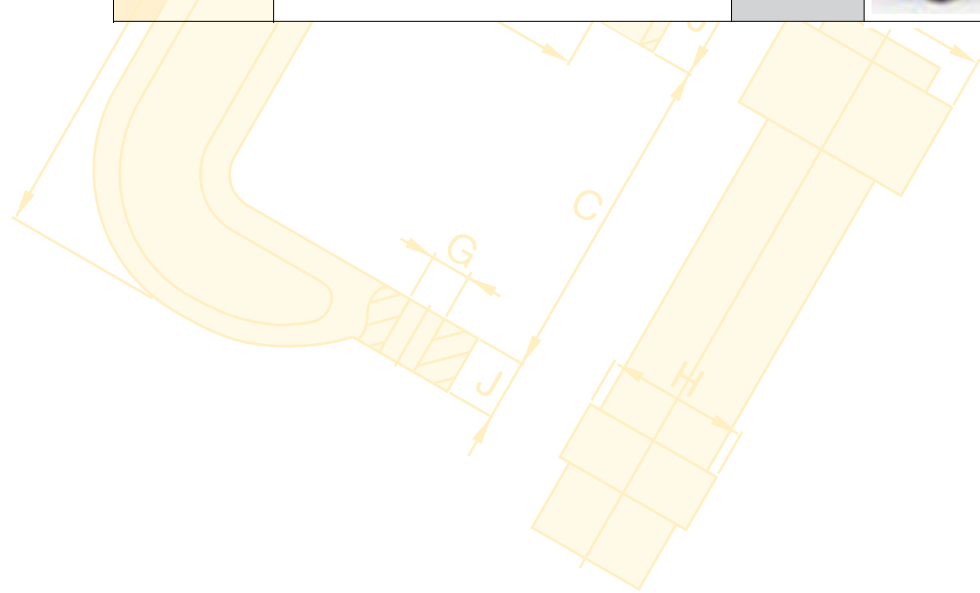

▼ Press shown: IPE5060



Setting the Industry Standard



Cylinder Mounting Block

Allows cylinder mounting into a press frame, while also allowing side to side adjustment of cylinder position.

Page: 176



Hydra-Lift™

Allows easy, effortless daylight adjustment. Standard on most H-Frame presses.

Page: 176



Pump Mounting Bracket

Heavy-duty steel brackets allow mounting of one of the Enerpac Power Sources to power your press.

Page: 176



Gauge Included

All standard press models include a gauge and gauge adaptor, matching the press capacity.

Page: 171



V-Blocks

These optional V-Blocks are designed for easy fixturing of round stock and other non-uniform materials. Featuring precise fit into the press bolster.

Page: 176

- Quality welded frame for maximum strength and long life
- Exclusive “Hydra-Lift™” bed for effortless adjustment of the vertical daylight (10-ton models are manual)
- Roller head design is standard to allow movement and locking of the cylinder from side to side (10 ton, 25 ton and 30 ton are manual)
- All models in the Quick Selection Chart have been matched to a pump, cylinder, hoses and gauge, offering the complete package



◀ An Enerpac H-Frame press quickly removes the shaft from this assembly.

H-Frame Presses



Ordering Variations

Any variations to a listed part number must be ordered as two separate items. For example, if you need a different voltage electric pump, please order from the modular matrix on page 177 and the electric pump from the modular matrix on page 115 (electric) or page 127 (air).

Any questions should be directed to our Technical Service Department.

Page: 176



Cylinder Types



= Single-acting, Spring Return



= Double-acting, Hydraulic Return

IP Series



Capacity:

10 - 200 tons

Maximum Daylight and Width:

54.50 & 48.00 inches

Maximum Operating Pressure:

10,000 psi

▼ QUICK SELECTION CHART

For more technical information see next page.

Press Capacity (tons)	Maximum Vertical Daylight (in)	Maximum Bed Width (in)	Power Source					Press Model Number	Cylinder			Speed (sec/in)*	
			Type			Valve			Stroke (in)	Rapid Advance	Pressing		
			Man.	Elec.	Air	Man.	Elec.						
10	40.00	18.63		●		●		●		10	0.90	6.70	
	40.00	18.63			●	●		●		10	2.20	13.40	
	40.00	18.63	●			●		●		10	{4}	{15}	
	40.00	18.63	●			●			●	10	{2}	{15}	
	40.00	18.63			●	●			●	10	2.20	13.40	
25	54.50	29.00		●		●		●		6	1.50	15.40	
	54.50	29.00		●			●	●		14	0.70	7.70	
	54.50	29.00			●	●		●		14	5.20	30.90	
	54.50	29.00	●			●		●		14	{5}	{34}	
30	54.50	29.00			●	●			●	14	0.60	43.00	
	54.50	29.00		●			●		●	14	0.90	9.80	
	54.50	29.00	●			●			●	14	{7}	{34}	
50	48.56	28.75		●			●	●		13	1.02	11.04	
	48.56	28.75			●	●		●		6	1.00	74.00	
	48.56	28.75	●			●		●		6	{2}	{38}	
	48.56	28.75	●			●		●		6	{11}	{73}	
	48.56	28.75		●		●		●		6	2.90	28.90	
	48.56	28.75			●	●			●	13	1.00	22.20	
	48.56	28.75		●			●		●	13	1.00	11.00	
	48.56	28.75	●			●			●	13	{2}	{38}	
100	41.00	35.00			●	●		●		10	1.90	41.20	
	41.00	35.00		●			●	●		10	1.90	20.60	
	41.00	35.00	●			●		●		10	{3}	{70}	
	41.00	35.00		●			●		●	13	1.90	20.60	
	41.00	35.00	●			●			●	6	{3}	{70}	
150	48.50	48.00		●			●	●		13	2.20	15.40	
200	48.50	48.00		●			●	●		13	3.10	22.10	

* {-} Speed in strokes per inch plunger travel



Hoses

All standard press models come with a hydraulic hose – HC9306 with the exception of IPA1220, IPA1244 comes with hydraulic hose – HC9308 and IPA2520 comes with hydraulic hose - HC9310.

Page: 148

▼ The moveable “cylinder mounting block” allows the user to quickly adapt the press to a specific job.



◀ For full features see page 174.

Press Capacity (tons)	Press Model Number	Pump Model Number	Page:	Cylinder Model Number	Page:	H-Frame Press Dimensions (in)					
						A (max)	A (min)	B	C	D	E
10	IPE1215	PEM1201B	102	RC1010	6	40.00	2.44	–	46.75	5.00	18.63
	IPA1220	XA12	125	RC1010	6	40.00	2.44	–	46.75	5.00	18.63
	IPH1240	P392	86	RC1010	6	40.00	2.44	–	46.75	5.00	18.63
	IPH1234	P84	88	RR1010	40	40.00	2.44	–	46.75	5.00	18.63
	IPA1244	XA12V	125	RR1010	40	40.00	2.44	–	46.75	5.00	18.63
25	IPE2505	PUJ1200B	100	RC256	6	54.50	7.00	–	57.00	11.88	29.00
	IPE2510	ZE3310SB-N	115	RC2514	6	54.50	7.00	–	57.00	11.88	29.00
	IPA2520	XA12	125	RC2514	6	54.50	7.00	–	57.00	11.88	29.00
	IPH2531	P80	88	RC2514	6	54.50	7.00	–	57.00	11.88	29.00
30	IPA3071	PAM1042	121	RR3014	40	54.50	7.00	–	57.00	11.88	29.00
	IPE3060	ZE3410SB-N	115	RR3014	40	54.50	7.00	–	57.00	11.88	29.00
	IPH3080	P84	88	RR3014	40	54.50	7.00	–	57.00	11.88	29.00
50	IPE5010	ZE4320SB-N	115	RC5013	6	48.56	7.06	18.76	54.00	10.38	28.75
	IPA5021	PAM1022	121	RC506	6	48.56	7.06	18.76	54.00	10.38	28.75
	IPH5030	P462	86	RC506	6	48.56	7.06	18.76	54.00	10.38	28.75
	IPH5031	P80	88	RC506	6	48.56	7.06	18.76	54.00	10.38	28.75
	IPE5005	PUJ1200B	100	RC506	6	48.56	7.06	18.76	54.00	10.38	28.75
	IPA5073	ZA4408MX	126	RR5013	40	48.56	7.06	18.76	54.00	10.38	28.75
	IPE5060	ZE4420SB-N	115	RR5013	40	48.56	7.06	18.76	54.00	10.38	28.75
	IPH5080	P464	88	RR5013	40	48.56	7.06	18.76	54.00	10.38	28.75
100	IPA10023	ZA4208MX	126	RC10010	6	41.00	5.50	20.00	51.00	11.69	35.00
	IPE10010	ZE4320SB-N	115	RC10010	6	41.00	5.50	20.00	51.00	11.69	35.00
	IPH10030	P462	86	RC10010	6	41.00	5.50	20.00	51.00	11.69	35.00
	IPE10060	ZE4420SB-N	115	RR10013	40	41.00	5.50	20.00	51.00	11.69	35.00
	IPH10080	P464	88	RR1006	40	41.00	5.50	20.00	51.00	11.69	35.00
150	IPE15065	ZE5420SG-N	115	RR15013	40	48.50	12.50	28.00	54.50	10.00	48.00
200	IPE20065	ZE5420SG-N	115	RR20013	40	48.50	12.50	28.00	54.50	10.00	48.00

H-Frame Presses

IP Series



Capacity:

10 - 200 tons

Maximum Daylight and Width:

54.50 & 48.00 inches

Maximum Operating Pressure:

10,000 psi

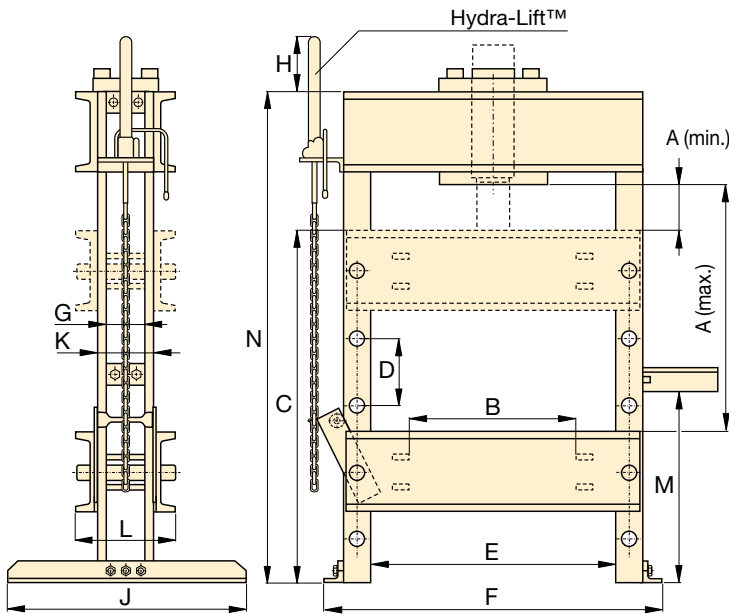

H-Frame Press Dimensions (in)									Weight (lbs)	Press Model Number
F	G	H	J	K	L	M	N			
24.88	-	-	29.75	4.25	7.44	35.00	52.00	298	IPE1215	
24.88	-	-	29.75	4.25	7.44	35.00	52.00	160	IPA1220	
24.88	-	-	29.75	4.25	7.44	35.00	52.00	158	IPH1240	
24.88	-	-	29.75	4.25	7.44	35.00	52.00	189	IPH1234	
24.88	-	-	29.75	4.25	7.44	35.00	52.00	163	IPA1244	
40.50	4.00	13.25	30.00	5.25	10.69	26.50	76.00	605	IPE2505	
40.50	4.00	13.25	30.00	5.25	10.69	26.50	76.00	697	IPE2510	
40.50	4.00	13.25	30.00	5.25	10.69	26.50	76.00	610	IPA2520	
40.50	4.00	13.25	30.00	5.25	10.69	26.50	76.00	620	IPH2531	
40.50	4.00	13.25	30.00	5.25	10.69	26.50	76.00	684	IPA3071	
40.50	4.00	13.25	30.00	5.25	10.69	26.50	76.00	722	IPE3060	
40.50	4.00	13.25	30.00	5.25	10.69	26.50	76.00	664	IPH3080	
42.75	5.00	8.75	36.00	7.25	14.38	30.75	76.00	1,040	IPE5010	
42.75	5.00	8.75	36.00	7.25	14.38	30.75	76.00	968	IPA5021	
42.75	5.00	8.75	36.00	7.25	14.38	30.75	76.00	968	IPH5030	
42.75	5.00	8.75	36.00	7.25	14.38	30.75	76.00	926	IPH5031	
42.75	5.00	8.75	36.00	7.25	14.38	30.75	76.00	930	IPE5005	
42.75	5.00	8.75	36.00	7.25	14.38	30.75	76.00	1,057	IPA5073	
42.75	5.00	8.75	36.00	7.25	14.38	30.75	76.00	1,051	IPE5060	
42.75	5.00	8.75	36.00	7.25	14.38	30.75	76.00	1,003	IPH5080	
51.00	5.75	8.75	36.00	8.75	17.25	33.13	76.00	1,650	IPA10023	
51.00	5.75	8.75	36.00	8.75	17.25	33.13	76.00	1,722	IPE10010	
51.00	5.75	8.75	36.00	8.75	17.25	33.13	76.00	1,656	IPH10030	
51.00	5.75	8.75	36.00	8.75	17.25	33.13	76.00	1,743	IPE10060	
51.00	5.75	8.75	36.00	8.75	17.25	33.13	76.00	1,665	IPH10080	
67.17	9.12	3.09	44.00	13.12	21.85	47.75	90.00	3,906	IPE15065	
67.17	9.12	3.09	44.00	13.12	21.85	47.75	90.00	3,906	IPE20065	



H-Frame Press Gauges

All standard press models include a gauge and gauge adaptor, matching the press capacity:

Press Capacity	Gauge Model Number	Adaptor Model Number
(tons)		
10	GF10P	GA2
25	GF20P	GA2
30	GF835P	GA3
50	GF50P	GA2
100	GF871P	GA3
150	GF200P	GA3
200	GF200P	GA3

For more information on gauges, please refer to the System Components section.

Page: 147



Ordering Variations

Any variations to a listed part number must be ordered as two separate items. For example, if you need a different voltage electric pump, please order from the modular matrix on page 177 and the electric pump from the modular matrix on page 115 (electric) or page 127 (air).

Any questions should be directed to our Technical Service Department.

Page: 176

▼ Shown: IPR10075



The One and Only



Cylinder Mounting Block

Allows cylinder mounting into a press frame, while also allowing side to side adjustment of cylinder position.

Page: 176



Pump Mounting Bracket

Heavy-duty steel brackets to allow conversion to one of the Enerpac Power Sources to power your press.

Page: 176



Hydra-Lift™

Allows easy, effortless daylight adjustment.

Page: 176



Optional V-Blocks

These V-Blocks, 200 ton only, are designed for easy fixturing of round stock and other non-uniform materials. Featuring precise fit into the press bolster.

Page: 176

- Quality welded frame for maximum strength and long life
- Frame rolls easily on four steel roller bearings
- Hydraulic clamp cylinders lock frame into position
- Exclusive “Hydra-Lift™” bolster for effortless adjustment of the vertical daylight
- Standard roller head design allows movement of the cylinder from side to side
- All models in the Quick Selection Chart have been matched to a pump, cylinder, hoses and gauge, offering the complete package
- Roll Frame design features a stationary bed with the ability to support heavy loads

Press Capacity (tons)	Vertical Daylight A (in)		Horizontal Daylight E (in)	Pump Model Number	Press Model Number	Cylinder, Double-Acting Hydraulic Return				Speed (sec/in)		
	minimum	maximum				Stroke (in)	Model Number	Page:	Rapid Advance	Pressing		
50	6.00	37.12	28.75	ZE4420SB-N	115	IPR5075	●	13.13	RR5013	41	1.0	11.1
100	6.28	41.28	35.00	ZE5420SG-N	115	IPR10075	●	13.13	RR10013	41	1.5	10.3
200	11.00	51.00	48.00	ZE5420SG-N	115	IPR20075	●	13.00	RR20013	41	3.1	22.1

Roll Frame Presses

▼ An IPR20075 Roll Frame Press is used to remove a large shaft from this pillow-block assembly. The Roll Frame design allows this heavy part to be safely loaded with an overhead crane.



IPR Series



Capacity:
50 - 200 tons

Maximum Daylight and Width:
51.00 & 48.00 inches

Maximum Operating Pressure:
10,000 psi



Roll Frame Press Gauges

All standard press models include a gauge and gauge adaptor, matching the press capacity:

Press Capacity	Gauge Model Number	Adaptor Model Number
(tons)		
50	GF50P	GA2
100	GF871P	GA3
200	GF200P	GA3

For more information on gauges, please refer to the System Components section.

Page: 147



Ordering Variations

Any variations to a listed part number must be ordered as two separate items. For example, if you need a different voltage electric pump, please order from the modular matrix on page 177 and the electric pump from the modular matrix on page 115 (electric) or page 127 (air).

Any questions should be directed to our Technical Service Department.

Page: 176

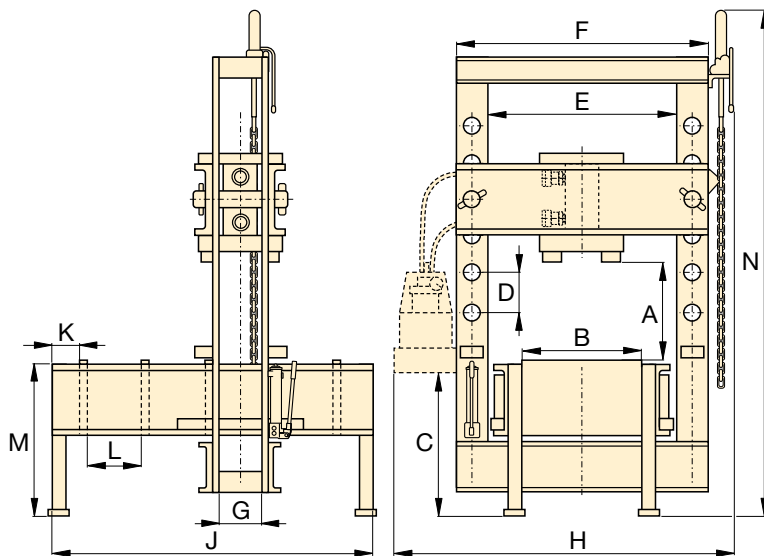

Roll Frame Press Dimensions (in)

Roll Frame Press Dimensions (in)											Weight	Press Model Number
B	C	D	F	G	H	J	K	L	M	N	(lbs)	
20.71	38.25	10.38	36.75	5.00	55.92	64.00	8.00	10.63	30.00	112.96	1,961	IPR5075
26.50	38.00	8.75	45.00	5.75	63.19	66.00	8.00	10.63	32.00	118.94	3,849	IPR10075
38.75	36.75	10.00	64.00	9.12	84.63	86.50	8.00	15.00	36.00	125.96	7,869	IPR20075

▼ Shown from left to right: A220 and A330



The Standard In Workshop Tools



Push Pin A183

For applications requiring precision pressing, such as shaft removal and insertion.

This attachment fits 10 ton cylinders and requires the use of a threaded adaptor saddle (A13).



Smooth Saddle A185

For pressing applications of delicate parts, such as aluminum castings, this saddle decreases surface marks during the pressing application.

Requires 10-ton cylinder and threaded adaptor saddle (A13).

C-Clamp Press

- 5, 10 and 20 ton capacity
- Operational in all positions

Arbor Press

- Foot mounting holes for horizontal or vertical positioning
- Machined work surfaces for easier fixturing
- Slotted back to simplify loading and unloading of longer parts

▼ A310 Arbor Press



Press Type	Press Capacity (tons)	Maximum Vertical Daylight (in)	Maximum Bed Width (in)	Cylinder Series Number*	Press Model Number	Weight (lbs)
Arbor	10	9.06	5.31	RC10-x	A310*	62
	30	10.00	7.00	RC30-x	A330*	220
C-Clamp	5	6.50	2.00	RC5-x	A205*	14
	10	9.00	3.25	RC10-x	A210*	37
	20	11.88	3.75	**	A220**	83

* Requires RC cylinder listed, see page 7 for specifications.

** Requires RC25 ton cylinder, limited to 20 tons.

C-Clamp and Arbor Presses



▲ RC-308 cylinder mounted in A-330 Arbor Press powered by a PATG-Turbo Air pump for controlled pressing of bearings for sprockets of weaving machines. The V-152 Pressure Relief Valve controls the pressing force.

A Series



Capacity:
5 - 30 ton

Maximum Daylight and Width:
11.88 and 7.00 inches

Mounting Capabilities:
Fixed or Portable

Maximum Operating Pressure:
10,000 psi



For high-cycle production applications, C-Clamp and Arbor presses should be limited in their capacity.

Consult Enerpac Technical Services for specific application details.

Top View Working Surface

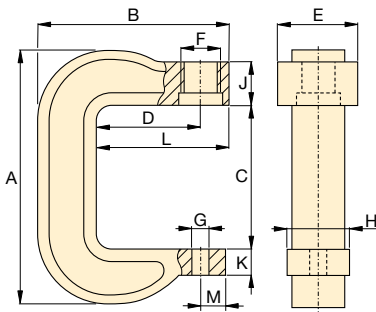
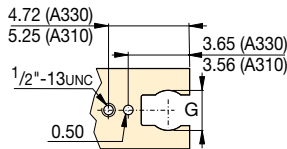

C-Clamp Press A205, A210, A220

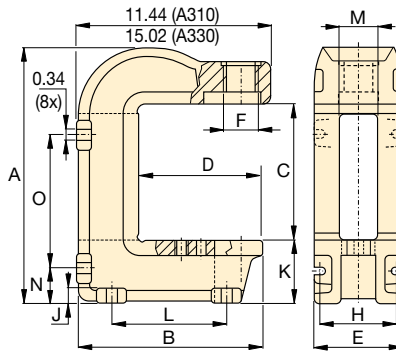

Arbor Press A310, A330

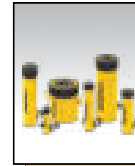

Hydraulic Cylinders

Cylinders for C-Clamps and Arbor Presses must be ordered separately.

Page: 6



Hydraulic Pumps

Pumps for C-Clamps and Arbor Presses must be ordered separately.

Page: 85

Press Dimensions (in)

Press Dimensions (in)														Press Model Number
A	B	C	D	E	F	G	H	J	K	L	M	N	O	
16.31	11.06	9.06	7.25	5.94	2¼-14 UN	2.50	4.81	0.75	3.75	6.88	2.56	2.13	8.63	A310*
22.18	14.02	10.00	7.40	7.00	3½-12 UN	2.50	5.50	1.10	6.63	8.00	2.63	3.88	10.88	A330*
11.44	8.00	6.50	3.75	2.88	1½-16 UN	1.02	2.00	2.50	1.06	4.75	1.00	-	-	A205*
16.00	11.13	9.00	6.00	3.25	2¼-14 UN	1.02	3.00	2.50	1.69	7.63	1.13	-	-	A210*
21.25	13.63	11.88	6.00	4.76	3½-12 UN	1.02	3.75	2.75	1.88	8.38	1.13	-	-	A220**

Description	Frame Capacity	Model Number		Features
Cylinder Mounting Block	10 ton H-Frame 25 and 30 ton H-Frame 50 ton H-Frame 100 ton H-Frame 200 ton H-Frame	IPK1012 IPK3012 PK501 PK1002 PK2002		<ul style="list-style-type: none"> All mounting blocks allow horizontal movement of cylinder
V- Blocks	10 ton H-Frame 25 and 30 ton H-Frame 50 ton H-Frame 100 ton H-Frame 150 & 200 ton H-Frame 200 ton Roll Frame	A136 A130 A150 A175 A200 A200R		<ul style="list-style-type: none"> Machined from high strength steel for long life All model numbers include two V-blocks
Hydra-Lift™	25-100 ton H-Frame 150-200 ton H-Frame 50 and 100 ton Roll Frame 200 ton Roll Frame	IPL100 IPL101 IPLR100 IPLR200		<ul style="list-style-type: none"> Allows easy, effortless daylight adjustments Includes accessory chain
Pump Mounting Bracket	Hand operated and small Air Pumps; P80, P84, P142, P392, PA133, XA, Turbo II pumps Electric, large Hand Pumps, and ZA4 Air Pumps; ZE Series, P462, P464, 10/90 Series Air Pumps	PMB1 PMB2		<ul style="list-style-type: none"> Both mounting brackets are pre-drilled to accept a number of different pump models

Cylinder Speed

This chart will help you calculate the time required for an Enerpac cylinder to extend when powered by a 10,000 psi Enerpac hydraulic pump. The Cylinder Speed Chart can also be used to determine the pump type and model best suited for an application when you know the plunger speed required.

Cylinder and Pump Selection Chart

Cylinder Capacity (tons)	Cylinder Load	Hand Operated Pumps				Electric Pumps					Air Pumps			
		Strokes per inch of plunger travel				Seconds per inch of plunger travel								
		Single Speed	Two-Speed			½ hp Port.	½ hp Subm.	ZE3 Series	ZE4 Series	ZE5 Series	@100 psi air			
			P391	P392	P80 P84						P462 P464	XA	PA133	PAM 10 Series
10	No load	15	4	2	1	0.7	0.9	0.3	0.2	0.2	1.10	2.70	0.21	0.16
	Load	15	15	15	8	6.7	6.7	3.4	2.2	1.1	9.00	16.80	14.90	4.50
25	No load	34	8	5	1	1.5	2.1	0.7	0.5	.4	2.60	6.20	0.48	0.36
	Load	34	34	34	18	15.5	15.5	7.7	5.2	2.6	20.60	38.60	34.30	10.30
30	No load	43	10	7	1	1.9	2.6	0.9	0.6	0.5	3.20	7.50	0.60	0.46
	Load	43	43	43	23	19.5	19.5	9.80	6.5	3.3	26.00	48.70	43.30	13.00
50	No load	73	16	11	2	3.3	4.4	1.50	1.0	0.8	5.50	13.30	1.00	0.80
	Load	73	73	73	38	33.2	33.2	16.6	11.0	5.5	44.20	82.92	73.70	22.10
100	No load	137	30	21	3	6.2	8.3	2.8	1.9	1.5	10.30	24.80	1.90	1.50
	Load	137	137	137	71	61.9	61.9	31.0	20.7	10.3	82.50	154.70	137.50	41.30

Note: Values are approximate. Cylinder speed may vary in actual application.

CUSTOM BUILD YOUR OWN PRESS

If the press that would best fit your application cannot be found in the charts, you can easily build your custom press here. All presses must be ordered with cylinders. The pump is ordered separately.

▼ This is how a press model number is built up:

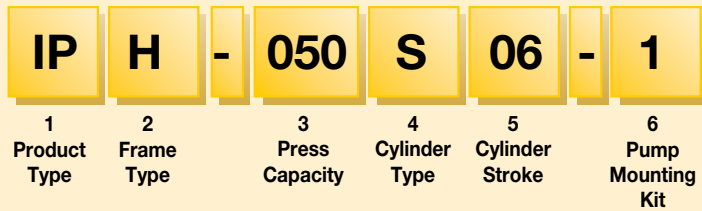

1 Product Type

IP= Industrial Press

2 Frame Type

H = H-Frame
R = Roll Frame ¹⁾

3 Press Capacity

010 = 10 ton
025 = 25 ton
030 = 30 ton
050 = 50 ton
100 = 100 ton
150 = 150 ton
200 = 200 ton

4 Cylinder Type

S = Single-Acting (RC-Series)
D = Double-Acting (RR-Series)

5 Cylinder Stroke (in)

- 10 ton S/A: **06, 08, 10, 12, 14**
10 ton D/A: **10, 12**
- 25 ton S/A: **06, 10, 12, 14**
- 30 ton S/A: **08**
30 ton D/A: **08, 14**
- 50 ton S/A: **06, 13**
50 ton D/A: **06, 13, 20**
- 100 ton S/A: **06, 10**
100 ton D/A: **06, 13, 18**
- 150 ton D/A: **06, 13, 32**
- 200 ton D/A: **13, 18, 24**

6 Pump Mounting Kit ²⁾

0 = No mounting kit
1 = Hand operated and small air pumps: P80, P84, P141, P142, P202, P391, P392, PA133 and all Turbo II Air pumps
2 = Electric, large hand operated and modular air pumps: PUJ12, PEM12, ZE36 Series P462, P464 PAM10 and -90 Series

¹⁾ Roll Frame Press: 50-, 100- and 200-ton press capacity only. (Assembly required)

²⁾ Includes hoses for press, except for option 0.

Ordering Example

Model number: IPH050S06-2

IPH050S06-2 is a 50-ton H-Frame press with a single-acting, 6-inch stroke cylinder (RC506). It has a pump mounting kit (for an electric Pump or a Modular Air Pump).

See the cylinder and pump selection chart on previous page for selecting the proper pump.

IP Series



Capacity:

10 - 200 tons

Maximum Daylight and Width:

54.50 & 48.00 inches

Maximum Operating Pressure:

10,000 psi



“No Load” indicates the plunger speed as it extends toward the load (1st stage).

“Load” indicates the plunger speed as the load is applied at a system pressure of 10,000 psi (2nd stage).

Formula $V = A \div Q$

V (sec/in) = A (in²) ÷ Q (in³/min)

V = Cylinder plunger speed in seconds per inch

A = Cylinder effective area in square inches (in²)

Q = Pump oil flow in cubic inches (in³)

Cylinder Plunger Speed (sec/in)	=	Cylinder Effective Area (in ²)	×	60 sec
		Pump Flow Rate (in ³ /min)		1

▼ Shown from left to right: XLP256XA11GU, XLP506XA12GU, VLP106P142U



No workshop can do without one



XA-Series Foot Pump

The XLP-Press with XA-Series Air Powered Foot Pump: no need to fully lift up foot – rest bodyweight on heel, resulting in a handsfree and stable working position – safe and controlled press operation.



Press Kits

The 50 and 75-ton presses come standard as unassembled kits, and include complete press frame, winch, cylinder, pump with gauge, couplers and hose.



Easy Grip Forklift Access

Cut-away in lower frame for pallet truck access allows easy transportation of 50 and 75-ton XLP-Series Presses.



Side-To-Side Cylinder Movement

Cylinder can be positioned horizontally side-to-side on all XLP-Series presses.

VLP-Series Bench Presses

- Compact design mounts conveniently on bench top
- Operational in vertical or horizontal position

XLP-Series Presses

- Easy height adjustment with integrated winch mechanism
- Horizontal cylinder adjustment enables flexible load placement
- Multiple pump options including pneumatic foot-controlled pumps with integrated gauges for optimal control and variable oil flow
- 50 and 75-ton units provided in kit form

Press Capacity	Maximum Vertical Daylight	Maximum Bed Width	Press Model Number	Power Source						Cylinder				
				Pump Type			Valve Type			Pump Model Number	S/A	D/A	Stroke	Cylinder Model Number
				Man.	Elec.	Air	Man.	Elec.	(in)					
10	16.73	17.13	VLP106P142U	●			●		P142	●		6.13	RC106	
	16.73	17.13	VLP106PAT1U			●	●		PATG1102N	●		6.13	RC106	
25	47.68	20.08	XLP256P392U	●			●		P392	●		6.25	RC256	
	47.68	20.08	XLP256XA11GU			●	●		XA11G	●		6.25	RC256	
50	37.80	38.98	XLP506P802U	●			●		P802	●		6.25	RC506	
	37.80	38.98	XLP506XA12GU			●	●		XA12G	●		6.25	RC506	
	37.80	38.98	XLP5013ZEBU		●			●	ZE4408SB		●	13.13	RR5013	
	37.80	38.98	XLP5013ZEIU		●			●	ZE4408SI		●	13.13	RR5013	
75	37.60	38.98	XLP756XA12GU			●	●		XA12G	●		6.13	RC756	



= Single-Acting



= Double-Acting



Bringing Value to the Workshop

The VLP- and XLP-Series Presses provide a simple and economical solution for standard workshop applications.

The 10-ton VLP comes standard with an RC cylinder and a hand or air pump. Compact and versatile, it's the ideal solution for pressing smaller workpieces from the comfort of a workbench.

The similarly equipped 25-ton XLP features a sturdy welded H-frame, an adjustable bolster and a horizontally adjustable cylinder.

The 50- and 75-ton XLP Presses offer an exceptional value with features including adjustable lower and upper bolsters, horizontally adjustable cylinders, single- and double acting cylinders*, and multiple pump options. These presses come standard as unassembled kits which include the frame, winch, cylinder, pump, gauge, couplers and hose.

For premium performance in more demanding applications, Enerpac also offers the IP Press Series,

which features heavy-duty welded frames and a broad range of cylinder and pump options. Contact Enerpac for additional information.

*On select models



All standard VLP and XLP models include a hose and gauge. The presses that come with an XA pump have the gauge integrated into the pump.

Press Capacity (tons)	Gauge Model Number	Hose Model Number
10	GF10P	HC7206
25	GF20P	HC7210
50	GF50P	HC7210
75	-	HC7210

For more information on gauges and hoses, please refer to the System Components section.

VLP, XLP Series



Capacity:

10 - 75 tons

Maximum Daylight and Width:

47.68 & 38.98 inches

Maximum Operating Pressure:

10,000 psi



IMPORTANT!

Workshop press frames are designed exclusively for pressing operations, not for pulling. For pulling applications please contact Enerpac.



Optional V-Blocks for VLP and XLP Presses

Place upright to facilitate the positioning of pipes and bars, or upside down to serve as a convenient work table. Each model number includes two V-blocks.

To be used with press (ton)	V-Blocks Model Number
10	VB10
25	VB25
50	VB501
75	VB101

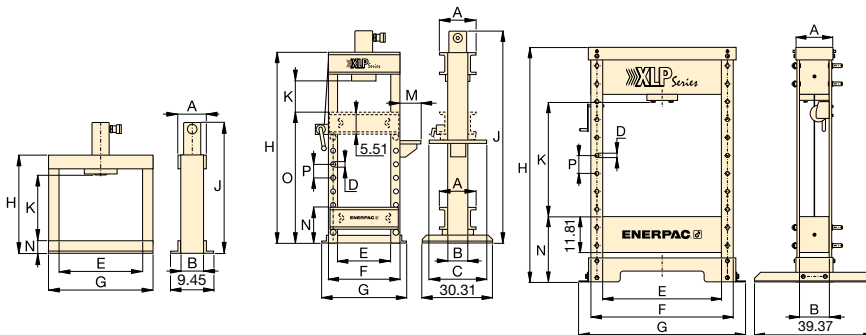

VLP 10 ton

XLP 25 ton

XLP 50, 75 ton

Speed (inches/sec) **		Dimensions (in)														Wt. (lbs)	Press Model Number
Rapid Advance	Pressing	A	B	C	D	E	F	G	H	J	K	M	N	O	P		
0.10**	0.02**	4.33	3.15	-	-	17.13	-	21.26	24.21	29.61	16.73	-	3.15	-	-	108	VLP106P142U
0.45	0.07	4.33	3.15	-	-	17.13	-	21.26	24.21	29.61	16.73	-	3.15	-	-	119	VLP106PAT1U
0.13**	0.03**	10.63	5.51	20.08	1.26	20.08	24.80	27.95	63.78	67.13	14.06-47.68	5.51	8.58	42.20	4.80	364	XLP256P392U
0.39	0.05	10.63	5.51	-	1.26	20.08	24.80	27.95	63.78	67.13	14.06-47.68	-	8.58	42.20	4.80	375	XLP256XA11GU
0.22**	0.01**	12.20	9.45	-	1.26	38.98	46.85	54.72	76.97	-	8.27-37.80	-	21.46	-	5.91	1312	XLP506P802U
0.18	0.02	12.20	9.45	-	1.26	38.98	46.85	54.72	76.97	-	8.27-37.80	-	21.46	-	5.91	1323	XLP506XA12GU
0.98	0.09	12.20	9.45	-	1.26	38.98	46.85	54.72	76.97	79.53	8.27-37.80	-	21.46	-	5.91	1530	XLP5013ZEBU
0.98	0.09	12.20	9.45	-	1.26	38.98	46.85	54.72	76.97	79.53	8.27-37.80	-	21.46	-	5.91	1530	XLP5013ZEIU
0.13	0.02	16.54	12.99	-	1.65	38.98	48.43	56.30	76.97	-	8.07-37.60	-	21.46	-	5.91	1984	XLP756XA12GU

** = speed in inches per hand pump stroke

▼ Shown: LH102 and TM5 (in middle)



TM, LH Series

Capacity:
2,000 to 200,000 lbs.

Accuracy, % of full scale:
± 2%



TM and LH models are 100% tested to verify accuracy within a ± 2% range.

If your application requires a calibrated tool, it must be submitted for certification testing.

Certification is NOT available from Enerpac.

Tension Meter TM5

- Accuracy, ± 2% of full scale
- Zinc and bronze plated to resist rust and corrosion
- Dual-range readout in kilograms and pounds
- Cushioned metal case provides safe storage and transport
- Maximum indicating pointer reading for pre-selected forces or to maintain maximum force readings

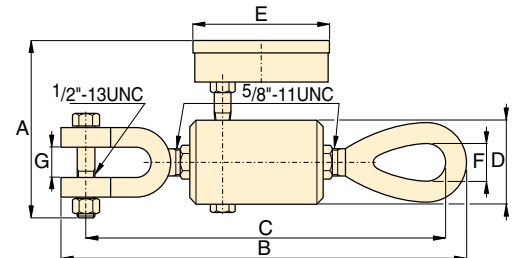

TM5

Load Cells LH Series

- Accuracy, ± 2% of full scale
- Swivel loading pad reduces eccentric loading for improved accuracy
- Maximum indicating pointer reading for pre-selected forces or to maintain maximum force readings
- Dual-range readout in kilograms and pounds

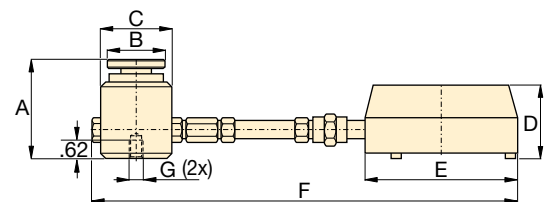

LH-Series

Type	Gauge Capacity		Model Number	Minimum Reading		Gauge Increments		Dimensions (in)						
	(lbs)	(kg)		(lbs)	(kg)	(lbs)	(kg)	A	B	C	D	E	F	G
Direct Mounted	10,000	4500	TM5	1,000	500	100	100	4.75	9.75	9.29	2.00	4.00	0.88	0.75
Direct Load Cell Mounted	2,000	900	LH10	200	100	20	20	3.06	1.75	2.25	2.38	4.00	10.00	1/4"-20, 1.75" BC
	10,000	4500	LH50	1,000	500	100	100	3.06	1.75	2.25	2.38	4.00	10.00	1/4"-20, 1.75" BC
Remote Mounted with 2 ft. Hose	2,000	900	LH102	200	100	20	20	3.06	1.75	2.25	2.38	5.81	33.31	1/4"-20, 1.75" BC
	10,000	4500	LH502	1,000	500	100	100	3.06	1.75	2.25	2.38	5.81	33.10	1/4"-20, 1.75" BC
	20,000	9000	LH1002	2,000	1000	200	200	3.06	1.75	2.25	2.38	5.81	33.10	1/4"-20, 1.75" BC
Remote Mounted with 6 ft. Hose	50,000	21000	LH2506	5,000	2500	500	500	4.00	2.75	3.38	2.38	5.81	82.44	3/8"-24, 2.5" BC
	100,000	45000	LH5006	5,000	2500	1,000	1000	5.22	4.00	5.00	2.38	5.81	84.06	3/8"-24, 3.5" BC
	200,000	90000	LH10006	20,000	10000	2,500	1000	6.22	5.00	6.25	2.38	5.81	85.31	3/8"-24, 4.0" BC

With decades of experience and in-house capabilities look to Enerpac to help find solutions to your customization needs.

Next to our large range of standard workshop presses, Enerpac offers the possibility of customization. Because many customers have specific requirements, we offer turn-key project management, including design, engineering and manufacturing. As the market leader, we listen to our customers and with our world

wide experience we offer the best solutions, especially when safety is not negotiable. Whether a longer stroke, wider frame or complete new design is required, our custom product group has many years of experience in multiple industries to deliver a solution that meets or exceeds expectations.



◀ *Fully Automated PLC-Controlled 1800-Ton, High-Accuracy Press*



◀ *50-Ton Workshop Press for Maintenance Jobs*



◀ *100-Ton Press for Assembly of Spring-Loaded Cylinders*

OVERVIEW



▲ *Enerpac's hydraulic presses can be configured to fulfill a broad range of applications. Each press is designed and manufactured according to customer specifications and in cooperation with our engineering team.*

CUSTOMIZABLE FEATURES:

- Capacity
- Cylinder Stroke
- Pump Type
- Controls
- Guarding
- Daylight Dimensions

CONFIGURATIONS

- Vertical and horizontal press
- Cylinders mounted in upper and lower bolsters
- Height built to customer specifications
- Daylight (vertical and horizontal) built to customer specifications

Enerpac offers a complete line of pullers with the widest range of sizes, capacities and styles. Whether your application requires mechanical or hydraulic force, Enerpac can satisfy your requirements.

Made of high strength steel alloys, you can depend on Enerpac pullers to provide years of trouble-free operation, even in the harshest environments.



Hydraulic Pullers

These hydraulic pullers eliminate time-consuming and unsafe hammering, heating or prying. Damage to parts is minimized through the use of controlled hydraulic power.



Lock-Grip Pullers

The puller's self-centering closing system allows all jaws to move simultaneously, making it easy for a single operator to mount the puller and to perform the application.



CAUTION!

Not all puller components and configurations are rated at the set capacity. Please contact Enerpac for specific details.



Always wear Safety Goggles and Gloves while using pullers.



Puller Section Overview

When selecting a puller it is important to consider three basic specifications:

1. Capacity:

The amount of force the puller is capable of producing.

Typically, the capacity required for a job can be determined by using the shaft diameter of the part being pulled.

For manual pullers, the center bolt diameter of the puller should be at least half the diameter of the shaft being pulled from.

For hydraulic pullers, the capacity in tons should be 7 to 10 times the shaft diameter. Use the following chart:











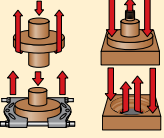

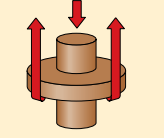

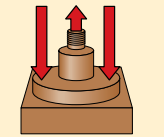

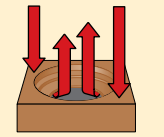

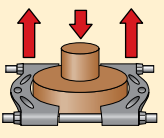

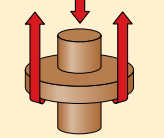

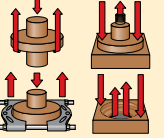

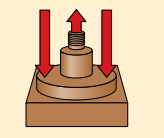
Shaft Diameter	Puller Capacity
0" to 1"	14 ton
1" to 2"	24 ton
2" to 3.5"	36 ton
3.5" to 5.5"	50 ton

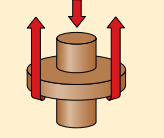
2. Reach:

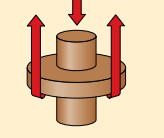
The distance between the bottom of the base and the jaw flats. The puller's reach must equal or exceed the same distance of the part being pulled.

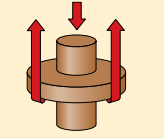
3. Spread:

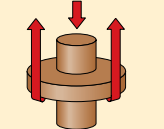
The distance between the jaws. The puller's spread needs to be greater than the width of the part being pulled.

Puller Function	Capacity (tons)	Puller Type	Series		Page
	14-50	Master Puller Sets Max. Reach: 27.56 in. Spread Range: 43.30 in.	BHP		184 ▶
	14-50	Grip Puller Sets Max. Reach: 27.56 in. Spread Range: 43.30 in.	BHP		185 ▶
	7-24	Cross-Bearing Puller Sets Max. Reach: 34.00 in. Spread Range: 22.83 in.	BHP		186 ▶ 193 ▶
	7-25	Bearing Cup Pullers Max. Reach: 5.91 in. Spread Range 9.45 in.	BHP		187 ▶
	7-25	Bearing Separator Max. Spread: 9.84 in. Max. Width 10.24 in.	BHP		187 ▶
	1-20	Mechanical Sync-Grip Puller Max. Reach: 4.13-23.62 in. Spread Range: 4.33-26.77 in.	SGM		190 ▶
	14-50	Hydraulic Sync-Grip Puller Sets Max. Reach: 12.60-27.56 in. Spread Range: 13.78-38.58 in.	MPS GPS SGH		191 ▶ 192 ▶
	3-40	Mechanical Lock-Grip Pullers Max. Reach: 4.02-13.19 in. Spread Range: 5.20-25.00 in.	LGM		194 ▶
	10-64	Hydraulic Lock-Grip Pullers Max. Reach: 8.46-16.06 in. Spread Range: 11.81-25.98 in.	LGH		196 ▶
	10-64	Hydraulic Lock-Grip Master Pullers Sets Max. Reach: 8.46-16.06 in. Spread Range: 11.81-25.98 in.	LGHMS		199 ▶
		Internal Mechanical Pullers Max. Reach: 1.77-3.11 in. Spread Range: 0.98-3.94 in.	IPM		200 ▶
	100	Posi Lock® Hydraulic Pullers Max. Reach: 48.0 in. Spread Range: 7.5-70 in.	EPH		201 ▶

▼ Shown: Master Puller Set BHP3751G



Multi-Purpose Puller Set



WARNING

Not all puller components and configurations are rated at the set capacity. Please contact Enerpac for specific details.

- Supplied with a full hydraulic set including pump, hose, cylinder, gauge and gauge adaptor in a storage case
- High quality, forged steel components provide superior reliability and service
- Sets include speed crank and adjusting screw for fast contact to work before hydraulics are applied
- All Master Puller Sets include a Grip Puller, a Cross Bearing Puller, a Bearing Cup Puller and a Bearing Separator which can be ordered separately. See items 10, 20, 30 and 40

▼ Maintenance engineers throughout the industry greatly appreciate Enerpac Master Puller sets.



▼ SELECTION CHART

Master Puller Set Capacity	14 ton	24 ton	36 ton	50 ton*	Page Number
Model Number ►	BHP1752	BHP2751G	BHP3751G	BHP5751G	
Included Hydraulics: Set Weight ►	82 lbs	198 lbs	380 lbs	657 lbs	
Hand Pump	P142	P392	P392	P80	86-89 ►
Cylinder	RWH121900	RCH202	RCH302	RCH603	34-35 ►
Saddle	-	HP2015	HP3015	HP5016	35 ►
Hose	HC7206C	HC7206C	HC7206C	HC7206C	149 ►
Gauge Adaptor Assembly	GA45GC	GA45GC	GA45GC	GA45GC	162 ►
Included Pullers:					
10 Grip Puller	BHP1762	BHP252	BHP352	BHP552	185 ►
20 Cross Bearing Puller	BHP1772	BHP262	BHP362	BHP562	186 ►
30 Bearing Cup Puller	BHP180	BHP280	BHP380	BHP580	187 ►
40 Bearing Separator	BHP181	BHP282	BHP382	BHP582	187 ►

* Puller capacity at 7,850 psi

▼ Shown: Grip Puller Set BHP351G



- Precise hydraulic control allows fast, efficient and safe pulling
- High quality, forged steel components provide superior reliability and service
- Available with and without full hydraulic set

BHP Series

Capacity:

14, 24, 36 and 50 tons

Maximum Reach:

9.92 - 27.56 inches

Spread Range:

9.84 - 43.30 inches

Maximum Operating Pressure:

10,000 psi



WARNING

Not all puller components and configurations are rated at the set capacity. Please contact Enerpac for specific details.

Ordering Example

Model Number BHP251G:

Includes Grip Puller BHP252 and a full hydraulic set. (Hand pump, cylinder, saddle, hose, gauge and gauge adaptor.)

Model Number BHP252:

Includes Grip Puller mechanical parts **only**, for use with your existing hydraulics.

▼ SELECTION CHART

Grip Puller Set Capacity		14 ton	24 ton	36 ton	50 ton**
Model Number	Included ►	BHP152	BHP251G	BHP351G	BHP551G
Hydraulics:	set weight ►	48 lbs	123 lbs	200 lbs	353 lbs
Hand Pump		P142	P392	P392	P80
Cylinder		RWH121900	RCH202	RCH302	RCH603
Saddle		–	HP2015	HP3015	HP5016
Hose		HC7206C	HC7206C	HC7206C	HC7206C
Gauge Assembly Adaptor		GA45GC	GA45GC	GA45GC	GA45GC
10 Grip Puller *	Model Number ►	BHP1762*	BHP252*	BHP352*	BHP552*
Spread Range (in)	2-jaw	9.84	15.75	23.38	35.43
	3-jaw	9.84	19.68	31.50	43.30
Maximum Reach (in)	2-jaw	9.92	11.81	15.25	27.56
	3-jaw	9.92	11.81	15.25	27.56
Jaw (in)	Thickness	0.59	0.79	0.98	1.18
	Width	0.94	1.10	1.50	1.57
Adjusting Screw (in)	Thread	¾"-16 UNF	1"-8 UNC	1¼"-7 UNC	1½"-5.5 UNS
	Length	15.75	26.38	31.16	38.39

* Grip Puller model number without hydraulics.

** Puller capacity at 7,850 psi

▼ Shown: Cross-Bearing Puller Set BHP361G



BHP Series

Capacity:

7, 12, 18 and 25 tons

Maximum Reach:

14.06 - 34.00 inches

Maximum Spread Range:

10.24 - 22.83 inches

Maximum Operating Pressure:

5000 psi



WARNING!

Not all puller components and configurations are rated at the set capacity. Please contact Enerpac for specific details.

- Precise hydraulic control allows fast, efficient and safe pulling
- High quality, forged steel components provide superior reliability and service
- The Cross-Bearing Puller without hydraulics, Bearing Cup Puller and Bearing Puller may be ordered separately. See items 20, 30 and 40

Cross Bearing Puller Sets			
Hand Pump	XA11G Air Pump	PUD1300 Electric Pump	XC1201M Cordless Pump
BHP162	BHP162A	BHP162EB *	BHP162CB *
BHP261G	BHP261GA	BHP261GEB *	BHP261GCB *
BHP361G	BHP361GA	BHP361GEB *	BHP361GCB *
BHP561G	BHP561GA	BHP561GEB *	BHP561GCB *

* EB for 115 V application
EE for 230 V application

▼ SELECTION CHART – Each set includes all items in columns*

Cross-Bearing Puller Set Capacity		7 ton	12 ton	18 ton	25 ton	
* SET Model Number ►		BHP162	BHP261G	BHP361G	BHP561G	
Included Hydraulics: set weight ►		57 lbs	137 lbs	267 lbs	408 lbs	
Hand Pump		P142	P392	P392	P80	
Cylinder		RWH121900	RCH202	RCH302	RCH603	
Saddle		–	HP2015	HP3015	HP5016	
Hose		HC7206C	HC7206C	HC7206C	HC7206C	
Gauge		GA45GC	GA45GC	GA45GC	GA45GC	
20	SET includes Cross-Bearing Puller Model Number ►	BHP1772	BHP262	BHP362	BHP562	
Spread (in)		Maximum	10.24	13.58	17.32	22.83
		Minimum	4.53	5.51	7.09	8.66
Reach (in)		Maximum	14.06	22.44	27.95	34.00
Adjusting Screw (in)		Diameter	¾"-16 UNF	1"-8 UNC	1¼"-7 UNC	1½"-5.50 UNS
		Length	15.75	26.38	31.10	38.39
Leg (in)		Length	4.17	4.53	8.07	23.98
		Length	14.06	9.45	18.11	34.02
		Length	–	16.54	27.95	–
		Length	–	22.44	–	–
Upper Leg Ends (in)		Thread	¾"-16 UNF	¾"-16 UNF	1"-14 UNS	1¼"-12 UNF
Lower Leg Ends (in)		Thread	5/8"-18 UNF	5/8"-18 UNF	1"-14 UNS	1¼"-12 UNF
30	SET includes Bearing Cup Puller Model Number ►	BHP180	BHP280	BHP380	BHP580	
40	SET includes Bearing Separator Model Number ►	BHP181	BHP282	BHP382	BHP582	
SET includes Wooden Case Model Number ►		CW166	CW166	CW550	CW750	

* Each set includes Cross-Bearing Puller, Bearing Cup Puller, Bearing Separator and Case

Bearing Cup Pullers and Bearing Separators

▼ Shown: BHP180



Bearing Cup Puller

- Made of high strength steel alloy
- Easily adapted to Cross Bearing Pullers for fast and efficient removal of the most difficult parts
- Adjustable to fit a variety of bearings and seals

BHP Series

Capacity:

7, 12, 18 and 25 tons

Maximum Reach:

4.53 - 5.91 inches

Maximum Spread Range:

5.71 - 9.84 inches

Maximum Operating Pressure:

5000 psi

▼ SELECTION CHART

Capacity*		7 ton	12 ton	18 ton	25 ton
30	Bearing Cup Puller				
	Model Number ▶	BHP180	BHP280	BHP380	BHP580
Spread (in)	Max.	5.71	6.30	9.45	9.45
	Min.	1.57	1.26	2.36	2.36
Reach (in)	Max.	4.53	5.51	5.91	5.91
	Center Screw Thread	3/4"-16 UNF	1"-8 UNC	1 1/4"-7 UNC	1 5/8"-5.50 UNS

* Bearing cup puller rated at 50% of puller capacity.



WARNING!

Do not exceed 50% of the rated puller capacity when using a double crosshead (2 grip arms) or when using puller legs in combination with bearing puller attachment.

▼ Shown: BHP181



Bearing Separator

- Made of high strength steel alloy
- Wedge-shaped edges allow removal of the most hard-to-grip components
- Easily adapted to Cross Bearing Pullers for fast and efficient removal of the most difficult parts

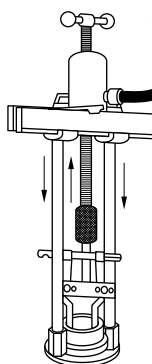

◀ Bearing Cup Puller shown with Cross Bearing Puller attachment.

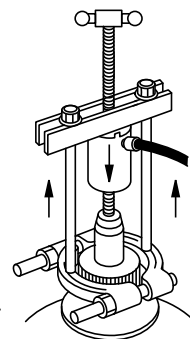

Bearing Separator shown with Cross Bearing Puller attachment. ▶

▼ SELECTION CHART

Capacity**		7 ton	12 ton	18 ton	25 ton
40	Bearing Separator				
	Model Number ▶	BHP181	BHP282	BHP382	BHP582
Spread (in)	Max.	4.33	5.28	9.84	9.84
	Min.	0.39	0.47	0.67	0.67
Width (in)		4.33	6.10	10.24	10.24
Thread		5/8"-18 UNF	5/8"-18 UNF	1"-14 UNS	1 1/4"-12 UNF

* Bearing separator rated at 50% of puller capacity.

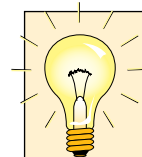

Bearing Separator

Bearing Separator has wedge shaped edges for placing puller behind hard to reach bearings, gears, etc., where clearance prevents direct application of grip puller arms.

The Bearing Separator should be used with the Cross Bearing Puller.

OVERVIEW

The Enerpac Sync Grip multi-purpose puller range is designed to make your jobs easier and safer to accomplish.

Remove bearings, bushings, gears, sleeves, wheels and flywheels, sprockets and other shaft mounted items simply and effectively.

Mechanical and hydraulic configurations are available with a variety of optional accessories that expand application range and increase utility.

Hydraulic models are available in standard sets which include detachable hydraulic cylinders and a choice of pump options, along with a gauge assembly and hose for safe monitoring of applied pulling forces.

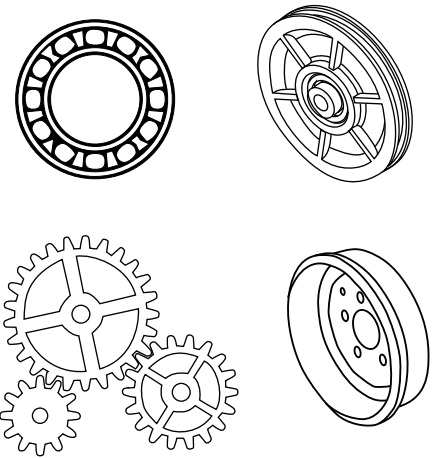

Always wear safety goggles and gloves while using pullers.

WARNING!
Do not exceed 50% of the rated puller capacity when using two jaw configurations.

▼ DIMENSIONAL DATA

Puller Capacity (ton)	Puller Model No.	Sync-Grip Pullers Dimensions (in)								Wt.*** (lbs)
		Standard Reach Jaws		Optional Extended Reach Jaws		Jaw Tip			Jaw Hole Spacing	
		Max. Reach A	Max. Spread B	Max. Reach A	Max. Spread B	Height D	Width E	Thickness F	(in)	
Mechanical Pullers										
1	SGM01*	4.13	4.33	—	—	0.31	0.28	0.30	0.75	1.8
4	SGM04*	7.28	6.89	—	—	0.30	0.31	0.83	2.01	4.4
7	SGM07*	8.86	9.45	—	—	0.39	0.31	0.98	1.75	14.3
10	SGM10*	16.14	13.78	19.29	15.94	0.49	0.59	0.98	3.27	32.0
20	SGM20	23.62	26.77	25.20	28.35	0.87	0.94	1.61	4.92	122.3
Hydraulic Pullers										
14	SGH14*	12.60	13.78	15.75	15.94	0.49	0.59	0.98	3.27	55.1
24	SGH24	12.60	18.90	17.13	21.26	0.61	0.69	1.22	4.53	108.0
36	SGH36	16.14	25.59	20.67	28.35	0.87	0.94	1.61	4.92	165.3
50**	SGH64	27.56	38.58	33.46	42.52	1.18	1.06	1.97	5.91	363.7
100	SGH100	39.37	63.00	—	—	1.79	1.94	2.76	9.84	842

* Puller can be set up as a 2 or 3 jaw configuration.

** Puller capacity at 7,850 psi, maximum cylinder capacity @ 10,000 psi is 64.6 tons.

*** With standard legs and cylinder for hydraulic models



Sync-Grip Pullers: available in both mechanical or hydraulic versions. Some models can be configured as a two jaw puller, however, three jaws are recommended for most even distribution of pulling forces.



Cross Puller: hydraulically powered via detachable cylinder and choice of pump. The Cross Puller can be used individually as a 'push' puller or in conjunction with the Bearing Separator or Bearing Cup Puller.



Bearing Separator: use where access is restricted. The Bearing Separator is used in conjunction with the Cross Puller.



Bearing Cup Puller: specifically designed for cup style bearing and other applications requiring an internal style puller.



Detachable Hollow Cylinder: provided with all hydraulic puller models including both the standard Sync Grip and Cross Puller.



In Sync Grip, Cross Bearing and Master Puller Sets, a hose and gauge are provided as standard along with your choice of pump; including manual hand operated, cordless battery powered, electric or air powered. In each case the pump selection has been optimized for compatibility with the pullers.



Easy To Use

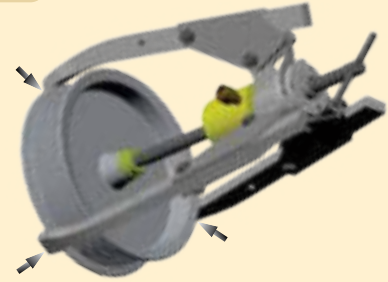

Simple, Safe, Productive

All three jaws close simultaneously making the puller easier and safer to operate.

The synchronous feature of the SGM and SGH-Series Pullers makes positioning the puller simple and helps prevent misalignment.

▼ DIMENSIONAL DATA

Cross Puller Dimensions (in)				Wt.**	Bearing Separator Dims. (in)				Wt.	Bearing Cup Dimensions (in)							Wt.
Standard Leg Height	Long Leg Height	Maximum Spread		Dia.	Spread Range		Thread Size		Height	Height	Spread Range		Jaw Tip				
A	A	B	(lbs)	A	Min. Spread	Max. Spread	C	(lbs)	A	B	Min. Spread	Max. Spread	Height	Width	Thickness	(lbs)	
Mechanical Pullers					Mechanical Pullers					Mechanical Pullers							
—	—	—	—	—	—	—	—	—	—	—	—	—	—	—	—	—	—
—	—	—	—	—	—	—	—	—	—	—	—	—	—	—	—	—	—
—	—	—	—	—	—	—	—	—	—	—	—	—	—	—	—	—	—
—	—	—	—	—	—	—	—	—	—	—	—	—	—	—	—	—	—
Hydraulic Pullers					Hydraulic Pullers					Hydraulic Pullers							
4.17	14.06	10.24	40.77	4.33	0.39	4.33	5/8" - 18 UNF	6.0	4.53	9.33	1.57	5.71	0.20	0.18	1.22	4.41	
4.53	22.44	13.58	76.04	6.10	0.47	5.28	5/8" - 18 UNF	12.6	5.51	10.47	1.26	6.30	0.18	0.18	0.98	5.29	
8.07	27.95	17.32	123.42	10.24	0.67	9.84	1" - 14 UNS	62.8	5.91	12.20	2.36	9.45	0.31	0.43	2.17	13.22	
23.97	34.01	22.83	250.15	10.24	0.67	9.84	1-1/4" - 12 UNF	62.8	5.91	12.20	2.36	9.45	0.31	0.43	2.17	14.11	
—	—	—	—	—	—	—	—	—	—	—	—	—	—	—	—	—	

** With cylinder and standard legs

▼ Shown: SGM10 with three jaws



SGM Series

Puller Capacity:

1 - 20 tons

Maximum Reach:

4.1 - 23.6 inches

Maximum Spread:

4.3 - 26.8 inches

- Sync-Grip mechanism synchronizes movement of all jaws for simultaneous engagement, helping to prevent misalignment for safe and easy use
- Threaded spindle and jaw indexes provide adjustable reach
- Three-jaw configuration for even load distribution
- Two-jaw configuration for confined access applications available on all pullers 10 ton and below (not available on SGM20)
- High-strength forged jaws for superior reliability
- Suitable for a variety of applications including bearings, bushings, wheels, gears and pulleys



Dimensions

Dimensional information for all puller models is included in the dimensional overview table:

Page: 188



WARNING!

Do not exceed 50% of the rated puller capacity when using two jaw configurations.

▼ SGM10 with two jaws.



▼ DIMENSIONAL DATA

Puller Capacity (ton)	Puller Model No.	Dimensions (in)		Weight (lbs)	Long Jaw Sets Model No.*	Dimensions (in)	
		Max. Reach A	Max. Spread B			Max. Reach A	Max. Spread B
1	SGM01	4.13	4.33	1.8	—	—	—
4	SGM04	7.28	6.89	4.4	—	—	—
7	SGM07	8.86	9.45	14.3	—	—	—
10	SGM10	16.14	13.78	32.0	SG1002K	19.29	15.94
20	SGM20	23.62	26.77	122.3	SG3002K	25.20	28.35

* Jaw sets include three jaws.

Hydraulic Sync-Grip Master Puller Sets

▼ Shown: **MPS14H**



SGH, MPS Series

Puller Capacity:

14 - 50 tons

Maximum Reach:

12.6 - 27.6 inches

Maximum Spread:

13.8 - 38.6 inches

Maximum Operating Pressure:

10,000 psi

- Sync-Grip mechanism synchronizes movement of all jaws for simultaneous engagement
- Hydraulically applied pulling force increases pulling capacity reducing operator fatigue
- Standard jaws adjust to accommodate different reach requirements. Optional long jaw sets available for additional reach requirements
- Designed for applications including pulling, pushing and dismantling gears, bearings, bushings, etc.



Dimensions

Dimensional information for all puller models is included in the dimensional overview table:

Page: 188



Sets Include:¹⁾

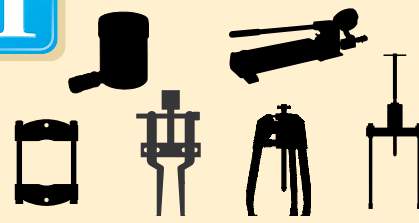

¹⁾ Choose pump options below.

▼ DIMENSIONAL DATA

Puller Capacity (ton)	Model No. (Puller and Cylinder)	Stroke (in)	Dimensions (in)		Wt. (lbs)	Hydraulic Puller Sets					Long Jaw Sets Model No. ^{***}	Dimensions (in)	
			Max. Reach A	Max. Spread B		Hand Pump	Air Pump	Electric Pump	Cordless Pump	All Sets Include:		Max. Reach A	Max. Spread B
14	SGH14	1.0	12.60	13.78	55.1	MPS14H	MPS14A	MPS14E	MPS14C	*	SG1002K	15.75	15.94
24	SGH24	2.0	12.60	18.90	108.0	MPS24H	MPS24A	MPS24E	MPS24C	GA45GC	SG2002K	17.13	21.26
36	SGH36	2.5	16.14	25.59	165.3	MPS36H	MPS36A	MPS36E	MPS36C	&	SG3002K	20.67	28.35
50**	SGH64	3.0	27.56	38.58	363.7	MPS64H	MPS64A	MPS64E	MPS64C	HC7206C	SG6002K	33.46	42.52

* 14-ton sets include an AR630 female coupler, GA45 gauge adaptor, and G2535L gauge.

** Puller capacity at 7,850 psi, maximum cylinder capacity @ 10,000 psi is 64.6 tons.

*** Jaw sets include three jaws.

For 115 V application add "B" suffix
For 230 V application add "E" suffix

▼ Shown: **GPS14H**



SGH, GPS Series

Puller Capacity:

14 - 100 tons

Maximum Reach:

12.6 - 39.4 inches

Maximum Spread:

13.8 - 63.0 inches

Maximum Operating Pressure:

10,000 psi

- Sync-Grip mechanism synchronizes movement of all jaws for simultaneous engagement
- Hydraulically applied pulling force increases pulling capacity and reduces operator fatigue
- Threaded spindle and jaw indexes provide adjustable reach
- Three-jaw configuration for even load distribution
- High-strength forged jaws for superior reliability
- The versatile puller set facilitates safe and easy dismantling in a variety of applications



Dimensions

Dimensional information for all puller models is included in the dimensional overview table:

Page: 188



Sets Include:¹⁾



¹⁾ Choose pump options below.

▼ DIMENSIONAL DATA

Puller Capacity (ton)	Model No. (Puller and Cylinder)	Stroke (in)	Dimensions (in)		Wt. (lbs)	Hydraulic Puller Sets					Long Jaw Sets Model No. ^{***}	Dimensions (in)	
			Max. Reach A	Max. Spread B								Max. Reach A	Max. Spread B
14	SGH14	1.0	12.60	13.78	55.1	GPS14H	GPS14A	GPS14E	GPS14C	*	SG1002K	15.75	15.94
24	SGH24	2.0	12.60	18.90	108.0	GPS24H	GPS24A	GPS24EE	GPS24CC	GA45GC	SG2002K	17.13	21.26
36	SGH36	2.5	16.14	25.59	165.3	GPS36H	GPS36A	GPS36E	GPS36C	&	SG3002K	20.67	28.35
50**	SGH64	3.0	27.56	38.58	363.7	GPS64H	GPS64A	GPS64E	GPS64C	HC7206C	SG6002K	33.46	42.52
100	SGH100	3.0	39.37	63.00	842.0	—	—	GPS100E	—	HC7206C	—	—	—

* 14-ton sets include an AR630 female coupler, GA45 gauge adaptor, and G2535L gauge.

** Puller capacity at 7,850 psi, maximum cylinder capacity @ 10,000 psi is 64.6 tons.

*** Jaw sets include three jaws.

For 115 V application add "B" suffix
For 230 V application add "E" suffix

Cross-Bearing Puller Sets

▼ Shown: Cross-Bearing Puller Set BHP361G



- Precise hydraulic control allows fast, efficient and safe pulling
- High-quality forged components provide superior reliability and service
- Quick set-up to tackle a variety of jobs

BHP Series

Puller Capacity:

7 - 25 tons

Maximum Reach:

14.1 - 34 inches

Maximum Spread:

10.2 - 22.8 inches

Maximum Operating Pressure:

10,000 psi



WARNING!

Enerpac cylinder and pump can be operated to 10,150 psi, but should not be operated past 5,075 psi when using the cross bearing puller set tools.



Dimensions

Dimensional information for all puller models is included in the dimensional overview table:

Page: 188



Sets Include:¹⁾

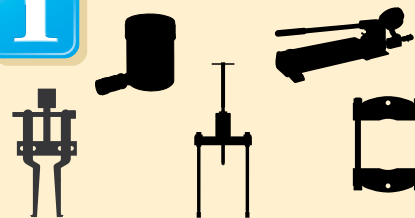

¹⁾ Choose pump options below.

▼ DIMENSIONAL DATA

Puller Capacity* (ton)	Cross-Bearing Only Model No.	Stroke (in)	Dimensions (in)		Cross Bearing Puller Sets			
			Maximum Reach A	Maximum Spread B	Hand Pump	Air Pump	Electric Pump	Cordless Pump
7	BHP1772	1.0	14.06	10.24	BHP162	BHP162A	BHP162E	BHP162C
12	BHP262	2.0	22.44	13.58	BHP261G	BHP261GA	BHP261GE	BHP261GC
18	BHP362	2.5	27.95	17.32	BHP361G	BHP361GA	BHP361GE	BHP361GC
25	BHP562	3.0	34.01	22.83	BHP561G	BHP561GA	BHP561GE	BHP561GC

* Cross Puller, Bearing Cup Puller and Bearing Separator rated at 50% of Grip Puller capacity.

For 115 V application add "B" suffix
For 230 V application add "E" suffix

LGM-Series, Mechanical Lock-Grip Pullers **ENERPAC**

▼ Shown: 2 and 3-Jaw Mechanical Lock-Grip Pullers



- Quickly and easily mount on a wide range of applications
- Lock-on jaws offer a secure grip for safe and easy operation
- Synchronous jaw movement enables entire pulling job to be performed by a single operator
- Available in 2 and 3-jaw configurations

▼ Lock-Grip Pullers – the simple, safe and cost-effective way to remove shaft-mounted parts.

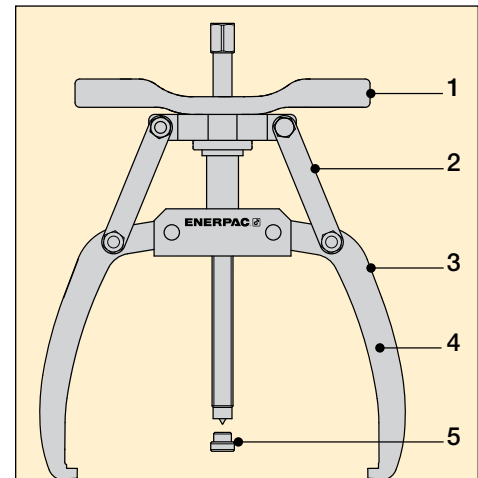

1. Convenient adjustment handle simplifies positioning of jaws on application and increases speed of operation.
2. Locking mechanism helps prevent puller jaws from slipping off application during pulling process.
3. Greater spreading width on top portion of jaws enables use on thicker objects.
4. Synchronous jaw movement increases ease of use, allowing one operator to mount the tool and perform the pulling application.
5. Point protector helps prevent damage to spindle when pulling against a flat surface.

Mechanical Lock-Grip Pullers



LGM-Series Pullers are an ideal solution for pulling small to medium-size wheels, sprockets, bearings and other similar shaft-mounted parts. The puller's self-centering closing system allows all jaws to move simultaneously, making it easy for a single operator to mount the puller and to perform the application.

Turning the puller handle locks the jaws onto the application, allowing the desired object to be pulled free when the spindle is turned.

LGM Series



Puller Capacity:

3 - 40 tons

Maximum Reach:

4.02 - 13.19 inches

Maximum Spread:

5.20 - 25 inches



IMPORTANT!

Always wear safety goggles and gloves while using pullers.



Point Protector

LGM-Series Pullers **MUST** be used with a point protector if the shaft end does not contain a drilled center hole.

One point protector is included with every puller.

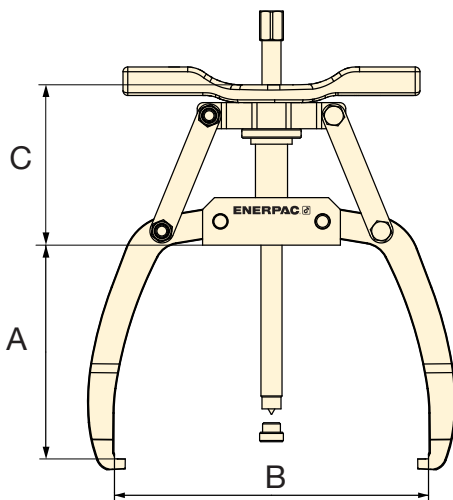
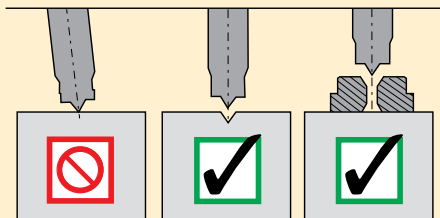

▼ SELECTION CHART

Puller Model No.	Dimensions (in)				Number of Jaws	Puller Capacity (ton)	Maximum Torque (ft-lbs)	Weight (lbs)	Replacement Point Protector Item Number
	Maximum Reach A	Minimum Spread Dia. B	Maximum Spread Dia. B	C					
	LGM203	4.02	1.10	5.20					
LGM305	4.02	1.10	5.20	2.36	3	5	50	4.62	
LGM204	5.59	1.18	7.32	3.54	2	4	50	5.50	
LGM306	5.59	1.18	7.32	3.54	3	6	74	6.82	
LGM207	6.97	1.38	10.24	5.28	2	7	87	10.78	SGM0704
LGM308	6.97	1.38	10.24	5.28	3	8	99	15.18	
LGM211	8.46	3.31	11.81	4.96	2	11	150	14.74	
LGM318	8.46	4.33	15.35	5.51	3	18	245	21.56	
LGM324	10.43	4.33	18.11	5.51	3	24	327	30.64	LGH14K6
LGM340	13.19	3.94	25.00	7.68	3	40	735	79.37	LGH24K6

LGH-Series, Hydraulic Lock-Grip Pullers ENERPAC®

▼ Shown: 2 and 3-Jaw Hydraulic Lock-Grip Pullers



- Quickly and easily mount on a wide range of applications
- Hydraulically applied pulling force increases pulling capacity, reducing operator fatigue
- Lock-on jaws offer a secure grip for safe and easy operation
- Synchronous jaw movement enables entire pulling job to be performed by a single operator
- Available in 2 and 3-jaw configurations with or without a detachable hollow cylinder



Point Protector

LGH-Series Pullers **MUST** be used with a point protector if the shaft end does not contain a drilled center hole.

One point protector is included with every puller.

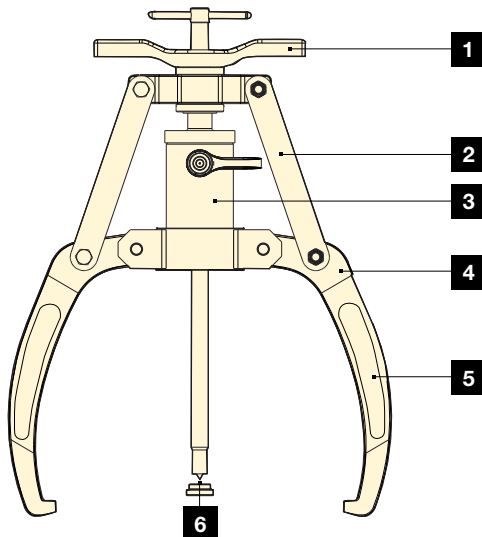
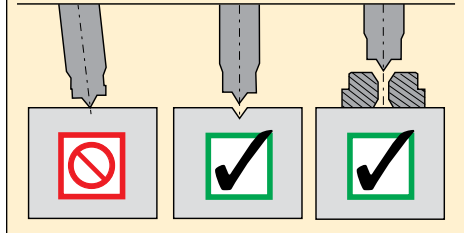

1. Convenient adjustment handle simplifies positioning of jaws on application and increases speed of operation.
2. Locking mechanism helps prevent jaws from slipping off application during pulling process.
3. Detachable hollow cylinder offers increased pulling capacity compared to mechanical alternatives.
4. Greater spreading width on jaws enables use on thicker objects.
5. Synchronous jaw movement increases ease of use, allowing one operator to mount the tool and perform the pulling application.
6. Point protector helps prevent damage to spindle when pulling against a flat surface.

Hydraulic Lock-Grip Pullers



LGH-Series Pullers provide the same safety and ease of use as their mechanical counterparts, with the pulling force applied by a standard 10,150 psi hydraulic cylinder. LGH-Series Pullers can apply up to 64 tons of force and are perfect for removing larger shaft-mounted objects up to 26 inches in diameter.

Turning the puller handle locks the jaws onto the application, allowing the desired object to be pulled free when the spindle is turned.

LGH Series



Puller Capacity:

10 - 64 tons

Maximum Reach:

8.46 - 16.06 inches

Maximum Spread:

11.81 - 25.98 inches

Maximum Operating Pressure:

10,150 psi



IMPORTANT!

Always wear safety goggles and gloves while using pullers.

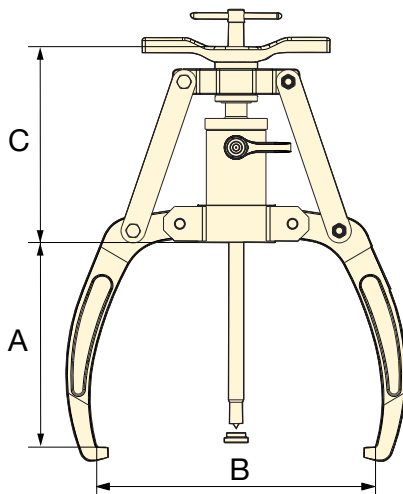

Model Numbers Without a Cylinder

To order a puller without cylinder, add "NC" after "LGH".

Example: LGHNC210



Sets Include:^{1) 2)}



¹⁾ Choose pump options below.

²⁾ All sets include hose model number HC7206C.

▼ DIMENSIONAL DATA

Puller Model No.*	Dimensions (in)				No. of Jaws	Puller Cap. (ton)	Wt. (lbs)	Replacement Point Protector Item Number	Hydraulic Puller Sets ^{1) 2)}			
	Max. Reach A	Min. Spread Dia. B	Max. Spread Dia. B	Max. Spread Dia. C					Hand Pump (P392) Gauge (GA45GC)	Air Pump (XA11G) Integrated Gauge	Electric Pump (PUD1300) Gauge (G2535L)	Cordless Pump (XC1201M) Gauge (GA45GC)
LGH210	8.46	3.31	11.81	7.56	2	10	22.66	SGM0704	—	—	—	—
LGH310	8.46	3.31	11.81	7.56	3	10	27.94	SGM0704	LGHS310H	LGHS310A	LGHS310E	LGHS310C
LGH214	10.24	4.92	14.96	7.32	2	14	31.24	LGH14K6	—	—	—	—
LGH314	10.24	4.92	14.96	7.32	3	14	40.04	LGH14K6	LGHS314H	LGHS314A	LGHS314E	LGHS314C
LGH224	13.23	6.50	18.90	12.80	2	24	82.28	LGH24K6	—	—	—	—
LGH324	13.23	6.50	18.90	12.80	3	24	104.06	LGH24K6	LGHS324H	LGHS324A	LGHS324E	LGHS324C
LGH253	16.06	9.06	25.98	18.62	2	53	243.76	LGH253K6	—	—	—	—
LGH364	16.06	9.06	25.98	18.62	3	64	306.90	LGH253K6	LGHS364H	LGHS364A	LGHS364EB	LGHS364C

*Standard models include cylinder. To receive puller without cylinder add "NC" after LGH (Example: LGHNC210).

For 115 V application add "B" suffix
For 230 V application add "E" suffix

Master Puller Set includes a hydraulic puller, cylinder, a pump with hose and gauge for standard pulling applications, as well as a selection of accessories designed for work environments where clearance prevents a direct application of the puller jaws.



Lock-Grip Pullers: All sets come with a hydraulic LGH-Series Puller. Both two jaw and three jaw versions are available.



Detachable Hollow Cylinder: Provided with all hydraulic pullers as well as the Cross Puller.



Pump with Hose and Gauge: Puller Sets and Master Puller Sets are supplied with a hose, gauge, and your choice of a hand, air, electric or cordless pump.



Cross Puller: Hydraulically powered via a detachable hydraulic cylinder and pump. The Cross Puller can be used individually as a 'push' puller, or in conjunction with the Bearing Separator or Bearing Cup Puller.



Bearing-Cup Puller: Specifically designed to pull cup style bearings and other applications requiring an internal style puller.



Bearing Separator (used with Cross Bearing Puller): Features narrow edges, which enable puller to be placed behind hard to reach bearings, gears, etc., where limited clearance prevents the direct application of puller arms.

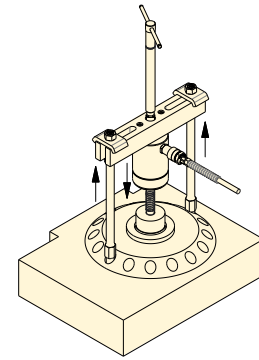

▲ Cross Puller on application

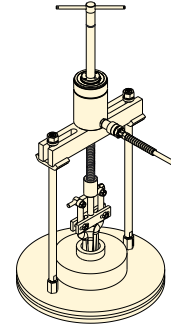

▲ Cross Puller with Bearing Cup Puller on application

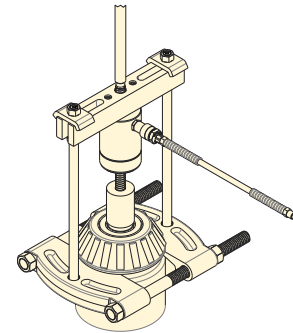

▲ Cross Puller with Bearing Separator on application

▼ DIMENSIONAL DATA

Puller Model No.	Cross Puller Dimensions (in)			Thread Size	Wt.* (lbs)	Bearing Separator Dimensions (in)				Wt. (lbs)	Bearing Cup Puller Dimensions (in)					Wt. (lbs)
	Model No.	A	Min. B			Model No.	A	Min. B	Max. B		Model No.	A	B	Min. C	Max. C	
LGH310	BHP112	11.02	4.53	5/8"-18 UNF	4.40	BHP181	4.33	0.39	4.33	6.16	BHP180	5.31	9.29	1.57	5.71	4.4
LGH314	BHP172	11.02	4.53	5/8"-18 UNF	4.62	BHP282	6.14	0.47	5.28	12.54	BHP190	6.46	10.43	1.57	5.71	4.62
LGH324	BHP272	14.57	5.51	5/8"-18 UNF	5.28	BHP292	7.17	0.51	8.27	27.5	BHP280	6.46	10.43	1.57	5.71	5.28
LGH364	BHP672	24.21	8.66	1 1/4"-12 UNF-2A	14.08	BHP682	11.81	0.79	11.81	95.7	BHP580	5.91	12.20	2.36	9.45	14.08

* With slotted crosshead, cylinder, and spindle

Hydraulic Lock-Grip Master Puller Sets

▼ Shown: LGHMS Master Puller Set with Hand Pump Option



LGHMS Series

Puller Capacity:
10 - 64 tons

Maximum Reach:
8.46 - 16.06 inches

Maximum Spread:
11.81 - 25.98 inches

Maximum Operating Pressure:
10,150 psi



WARNING!
Enerpac cylinders and pumps can be operated to 10,150 psi, but should not be operated past 5,000 psi when using the Cross Bearing Puller Set tools.

- All LGHMS-Series Master Puller Sets include an LGH-Series Puller, a Cross Puller, a Bearing Separator, a Bearing Cup Puller, a detachable Hollow Cylinder, a hose, a gauge and a pump
- Set options include hand, air, electric and cordless pumps for an optimal solution to every application



Dimensions

Dimensional information for all puller models is included in the dimensional overview table:

Page: 188





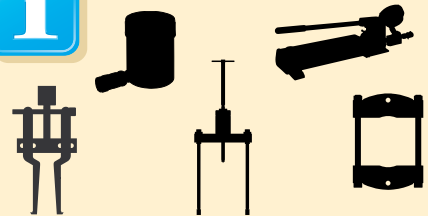

Sets Include:^{1) 2)}



¹⁾ Choose pump options below.

²⁾ All sets include hose model number HC7206C.

▼ DIMENSIONAL DATA

Puller Model No.	Dimensions		Number of Jaws	Puller Capacity (ton)	Replacement Point Protector Item Number	Hydraulic Master Puller Sets ^{1) 2)}			
	Minimum Spread (in)	Maximum Spread (in)							
						Hand Pump (P392) Gauge (GA45GC)	Air Pump (XA11G) Integrated Gauge	Electric Pump (PUD1300) Gauge (G2535L)	Cordless Pump (XC1201M) Gauge (GA45GC)
LGH310	3.31	11.81	3	10	SGM0704	LGHMS310H	LGHMS310A	LGHMS310E	LGHMS310C
LGH314	4.92	14.96	3	14	LGH14K6	LGHMS314H	LGHMS314A	LGHMS314E	LGHMS314C
LGH324	6.50	18.90	3	24	LGH24K6	LGHMS324H	LGHMS324A	LGHMS324E	LGHMS324C
LGH364	9.06	25.98	3	64	LGH253K6	LGHMS364H	LGHMS364A	LGHMS364E	LGHMS364C

For 115 V application add "B" suffix
For 230 V application add "E" suffix

IPM-Series, Internal Mechanical Pullers **ENERPAC**

▼ Shown: **IPM3**



IPM Series

Maximum Reach:

1.77 - 3.11 inches

Spread Range:

0.98 - 3.94 inches



IMPORTANT!

Always wear Safety Goggles and Gloves while using pullers.

- Remove bearings or other shaft-mounted parts where no spindle support is available
- Slide hammer allows for application of safe, high-impact force
- Includes two sets of jaws for internal and external pulling applications

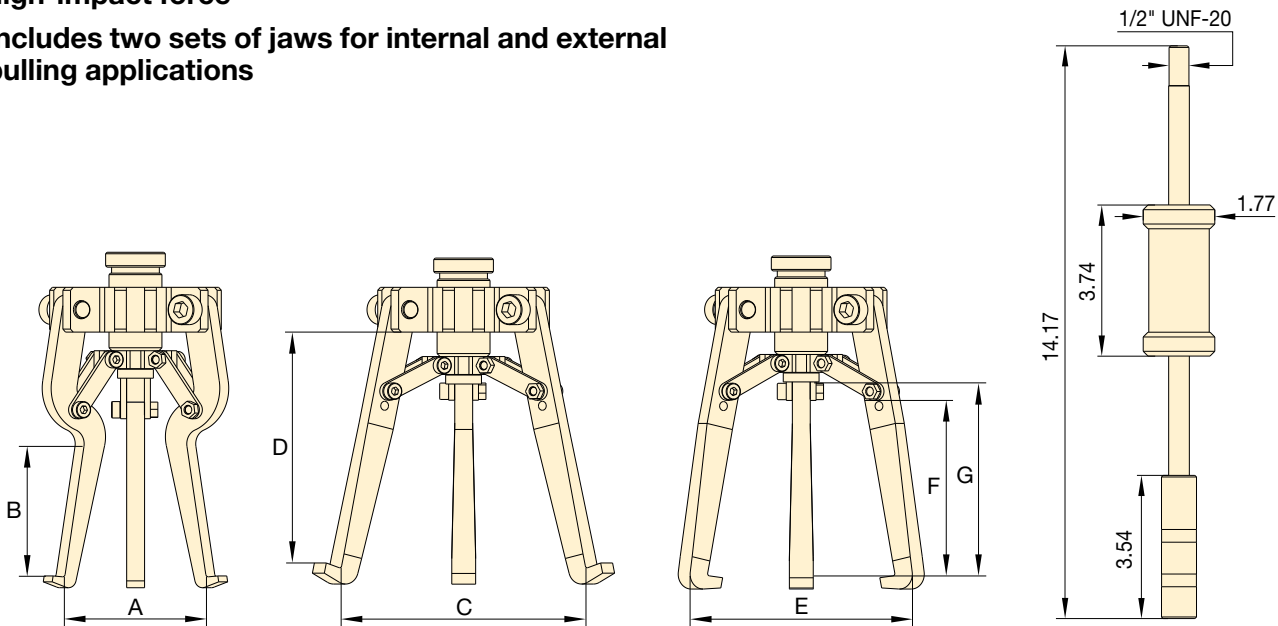

Slide Hammer Dimensions (in)

▼ DIMENSIONAL CHART

Model Number	Internal Jaw Dimensions (in)		Standard Jaw Dimensions (in)							Weight (lbs)	
			Internal Configuration			External Configuration					
	Spread Diameter		Maximum Reach	Spread Diameter		Maximum Reach	Spread Diameter		Maximum Reach		
	(min)	(max)	B	(min)	(max)	D	(min)	(max)	F	G	
IPM3	0.98	2.36	1.77	2.36	3.94	3.11	0.59	2.95	2.16	2.75	4.60

Posi Lock® 100-Ton Hydraulic Grip Pullers

▼ EPH1003



- Roller cart with power lift
- Adjustable jaw tips
- Puller easily detaches from cart
- Self-contained unit
- Puller height range 26.5" to 66.5"

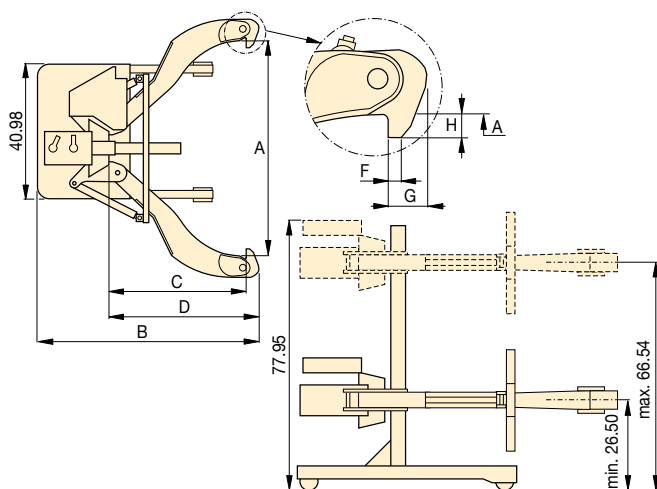

EPH Series

Capacity:

100 tons

Maximum Reach:

48 inches

Spread Range:

7.5 - 70 inches

Maximum Operating Pressure:

10,000 psi



Pushing Adaptors

All Posi Lock 100 Ton Hydraulic Pullers include (3) pushing adaptors.

Diameter (in)	Overall Length (in)	Model Number
3.5	29	EPHT1162
3.5	19	EPHT1163
3.5	9	EPHT1164



▲ The EPH1002 quickly and easily removes this drive coupler from its shaft.

Number of Jaws	Max. Spread (in)	Capacity (tons)	Model Number	Dimensions (in)							Weight (lbs)
				Spread Range	Overall Length	Reach (max.)	Jaw Length	Jaw Width	Tip Clearance	Tip Depth	
				A	B	C	D	F	G	H	
2	70.00	100	EPH1002	7.5-70.0	77.00	48.00	53.00	1.25	3.5	3.5	1700
3	70.00		EPH1003	7.5-70.0	77.00	48.00	53.00	1.25	3.5	3.5	1950

Enerpac offers an extensive range of dedicated tools for a variety of specific and flexible applications. Whatever your requirement... punching, spreading or bending... you can be sure that Enerpac has the correct tool to do your job safely and efficiently.

Featuring maintenance sets, machine lifts and load skates, as well as hole punches pipe benders and cable cutters, Enerpac has the tools to ensure that even your most demanding applications can be undertaken with the highest degree of safety and accuracy.

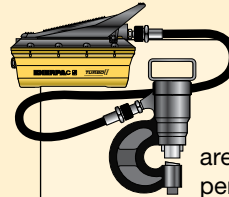

Pump and Tool Sets

Selected hydraulic tools in this section are available in sets, for a perfect tool/pump match.



Hydraulic System Setup

Check out our "Yellow Pages" section for help on system setups and valving configurations.

Page: 399











Hydraulic, Electric and Manual Cutters

Enerpac Cutters can be found in the Cutter section of this catalog.

Page: 221



Specialty Tool Section Overview

Capacity (tons)	Tool Type and Functions	Series		Page
2.5 - 12.5	Maintenance Sets	MS		204 ▶
35 - 50	Punch, Punch Sets	SP MSP STP		208 ▶
16	Lifting Wedge	LW		212 ▶
8.5 - 20	Hydraulic Machine Lifts	SOH		213 ▶
1 - 80	Heavy-Duty Load Skates	ER ES ELP		214 ▶
0.67 - 16 (cu. feet)	Industrial Storage Cases	CM		216 ▶
0.75 - 1.00	Hydraulic Wedgie Spread Cylinders	A WR		217 ▶
Nominal Bore 1/2 - 4 inches	Pipe Bender Sets	STB		218 ▶

▼ Shown: MS210



The Universal Hydraulic Tool Box



Maintenance Sets

Enerpac Maintenance sets are a complete assortment of accessories matched to hydraulic powered tools. Using these sets allows you to quickly configure a unique tool to meet your most difficult jobs.

Built around the Enerpac lightweight hand pump, hose and cylinder, these sets enable you to push, pull, lift, press, straighten, spread and clamp with forces up to 12.5 tons.

- All sets include Enerpac pump, hose, cylinder and gauge
- Lock-on or threaded connectors
- Complete set for almost every maintenance application



More Information

For detailed information on all included attachments, see the following pages.

Page: 206



Clamping a workpiece is just one of the many applications for the Enerpac maintenance sets. ►

▼ QUICK SELECTION CHART

Capacity using attachments* (tons)	Set Model Number						Number of Attachment Components	Weight (lbs)
2.5	MS24	P142	HC7206	RC55	GP10S	GA4	33	59
2.5	MSFP5**	P142	HC7206	RC55	G2535L	GA3	24	44
5	MSFP10	P392	HC7206	RC106	G2535L	GA3	23	105
5	MS210	P392	HC7206	RC106	GP10S	GA2	35	140
12.5	MS220	P392	HC7206	RC256	GP10S	GA2	13	210
5 - 12.5	MS21020	P392	HC7206	RC102, 106, 256	GP10S	GA2	53	350

* If no attachments are being used, capacity is double these values. Maximum operating pressure is then 10,000 psi.

** This set also includes the FZ1055 Adaptor.

MS-Series, Maintenance Sets



CAUTION!

When cylinders are used with maintenance set attachments or components, the maximum system pressure must be limited to half the rated pressure (5,000 psi).



WARNING!

Only use attachments provided with set. Non Enerpac attachments and longer extension tubes will reduce column strength, potentially creating unsafe conditions.

MS Series



Capacity (using attachments):

2.5 - 12.5 tons

Max. Operating Pressure (using attachments):

5,000 psi

▼ APPLICATION EXAMPLES

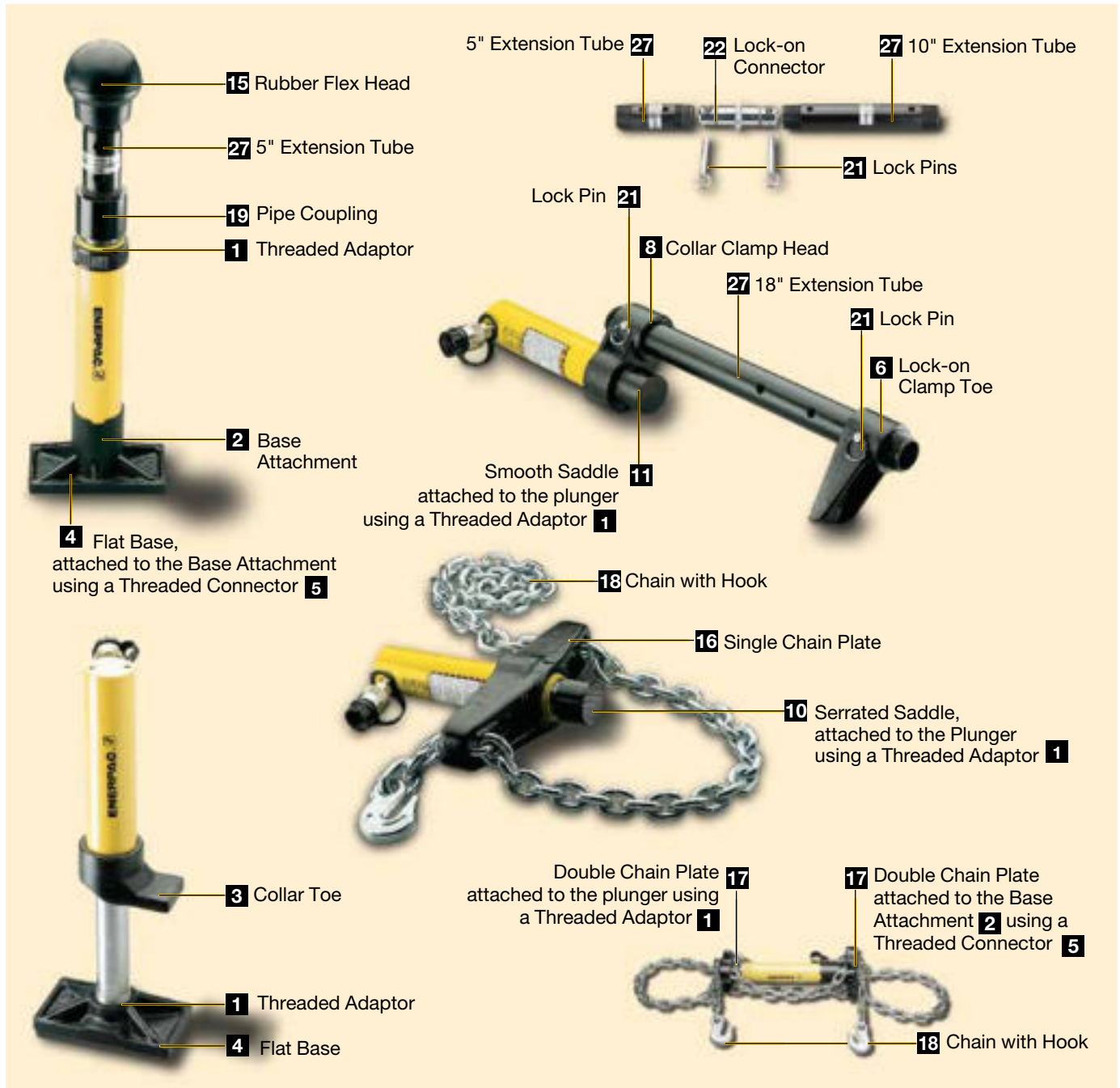



CAUTION! When cylinders are used with maintenance set attachments or components, the maximum system pressure must be limited to half the rated pressure (5,000 psi).

Note: All dimensions in inches.

Set Model No.	MS2-4	MSFP5	MSFP10	MS2-10	MS2-20	MS2-1020
Base/Collar/ Plunger Attachments	Capacity Using Attachments					
	2.5 tons	2.5 tons	5.0 tons	5.0 tons	12.5 tons	5-12.5 tons
Cylinder Series	RC5	RC5	RC10	RC10	RC25	RC10, RC25
1	A23	A23	A13	A13	A28	A13 / A28
2	A25	A25	A21	A21	A27	A21 / A27
3	A1034	A1034	A20	A20	A595	A20 / A595
4	MZ4010	MZ4010	A14	A14	A243	A14 / A243
5	A545	A545	A10	A10	—	A10(2x)
6	—	—	—	A8	—	A8
7	A530	A530	A6	A6	—	A6
8	MZ4011	—	—	A192	—	A192
9	—	—	—	A305	—	A305
10	A531	A531	A18	A18	—	A18
11	—	—	—	A185	—	A185
12	A532	A532	A15	A15	—	A15
13	—	—	—	—	A607	A607
14	A629	A629	A129	A129	—	A129
15	A539	A539	A128	A128	—	A128
Chains and Attach- ments for Pulling	2.5 tons	2.5 tons	5.0 tons	5.0 tons	12.5 tons	5-12.5 tons
Cylinder Series	RC5	RC5	RC10	RC10	RC25	RC10, RC25
16	A558	—	—	A132	A238	A132, A238
17	—	—	—	A5 (2x)	—	A5(2x)
18	A557(2x)	—	—	A141(2x)	A218(2x)	A141(2x) / A218(2x)
 Tubes, Connectors and Adaptors	2.5 tons	2.5 tons	5.0 tons	5.0 tons	12.5 tons	5-12.5 tons
Cylinder Series	RC5	RC5	RC10	RC10	RC25	RC10, RC25
19	A544	—	—	A19(2x)	A242(2x)	A19(2x) and A242(2x)
20	WR5	WR5	WR5	A92	—	A92
21	MZ4013(4x)	MZ4013(4x)	A16(4x)	A16(4x)	—	A16(4x)
22	MZ4007(3x)	MZ4007(3x)	MZ1050(3x)	MZ1050(2x)	—	MZ1050(3x)
23	MZ4008(2x)	—	—	MZ1051	—	MZ1051(2x)
24	MZ4009	MZ4009	MZ1052	MZ1052	—	MZ1052
25	—	—	—	A285	—	A285
26	A650	—	—	—	—	—
Length: 3"	MZ4002	MZ4002	—	—	—	—
	5"	MZ4003	MZ4003	MZ1002	MZ1002	—
	10"	MZ4004	MZ4004	MZ1003	MZ1003	A239
						and A239
	18"	MZ4005(2x)	MZ4005	MZ1004	MZ1004	A240
						and A240
	23"	MZ4006	MZ4006	—	—	—
	30"	—	—	MZ1005	MZ1005	A241
						and A241
Case	CM6	CM6	CW166	CW166	CW166	CW350
Weight	59 lbs.	44 lbs.	105 lbs.	140 lbs.	210 lbs.	350 lbs.

Base/Collar/Plunger Attachments

1 Threaded Adaptor

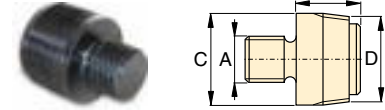

Tons	Model No.	A	B	C	D
2.5	A23	3/4"-16 UN	1.13	1.05	3/4"-14 NPT
5.0	A13	1"-8 UN	1.25	2.19	1 1/4"-11 1/2 NPT
12.5	A28	1 1/2"-16 UN	1.87	2.75	2"-11 1/2 NPT

2 Base Attachment



Tons	Model No.	A	B	C	D
2.5	A25	3/4"-14 NPT	2.00	0.50	1.75
5.0	A21	1 1/4"-11 1/2 NPT	2.25	0.50	2.56
12.5	A27	2"-11 1/2 NPT	2.50	0.50	3.88

3 Collar Toe

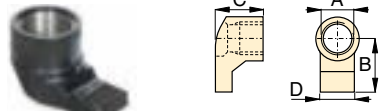

Tons	Model No.	A	B	C	D
2.5	A1034	1 1/2"-16	2.13	1.97	1.25
5.0	A20	2 1/4"-14	3.16	2.25	2.25
12.5	A595	3 3/16"-12	4.06	2.03	3.18

4 Flat Base



Tons	Model No.	A	B	C	D
2.5	MZ4010	3/4"-14 NPT	4.50	1.25	2.50
5.0	A14	1 1/4"-11 1/2 NPT	6.50	1.38	3.50
12.5	A243*	2"-11 1/2 NPT	6.50	2.31	6.50

* A243 is a round base model

5 Threaded Connector

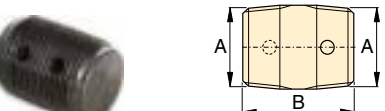

Tons	Model No.	A	B
2.5	A545	3/4"-14 NPT	1.38
5.0	A10	1 1/4"-11 1/2 NPT	1.63

6 Lock-on Clamp Toe

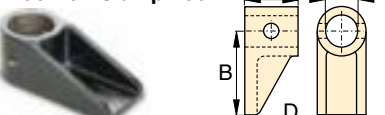

Tons	Model No.	A	B	C	D
5.0	A8	1.69	4.13	2.00	2.25

MS-Series, Maintenance Sets

7 Threaded Plunger Toe



Tons	Model No.	A	B	C	D
2.5	A530	3/4"-14 NPT	2.25	1.00	1.33
5.0	A6	1 1/4"-11 1/2 NPT	3.12	1.25	2.25

8 Collar Clamp Head

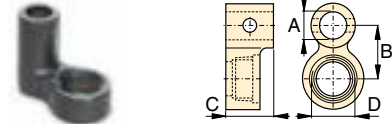

Tons	Model No.	A	B	C	D
2.5	MZ4011	3/4"-14 NPT	1.95	3.00	1 1/2-16 UN
5.0	A192	1.69	2.50	2.00	2 1/4-14 UN

9 Spreader Toe



Tons	Model No.	A	B	C	D
5.0	A305	1 1/4"-11 1/2 NPT	4.50	1.00	2.00

10 Serrated Saddle

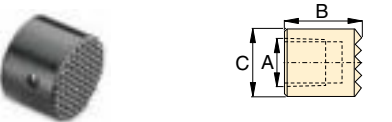

Tons	Model No.	A	B	C
2.5	A531	3/4"-14 NPT	1.25	1.09
5.0	A18	1 1/4"-11 1/2 NPT	1.50	2.00

11 Smooth Saddle

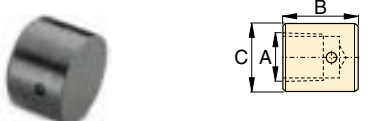

Tons	Model No.	A	B	C
5.0	A185	1 1/4"-11 1/2 NPT	1.50	2.00

12 90° V-Base

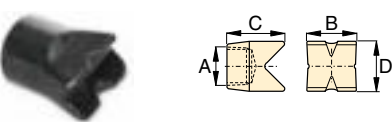

Tons	Model No.	A	B	C	D
2.5	A532	3/4"-14 NPT	1.50	1.88	1.00
5.0	A15	1 1/4"-11 1/2 NPT	2.13	2.25	2.13

13 Plunger Base

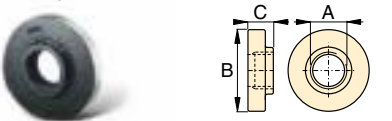

Tons	Model No.	A	B	C
12.5	A607	2"-11 1/2 NPT	6.56	1.53

14 Wedge Head



Tons	Model No.	A	B	C	D
2.5	A629	3/4"-14 NPT	2.75	1.31	1.13
5.0	A129	1 1/4"-11 1/2 NPT	4.00	2.00	1.75

15 Rubber Flex-Head



Tons	Model No.	A	B	C
2.5	A539	3/4"-14 NPT	1.75	2.75
5.0	A128	1 1/4"-11 1/2 NPT	3.40	3.40

Chains and Attachments for Pulling

16 Single Chain Plate

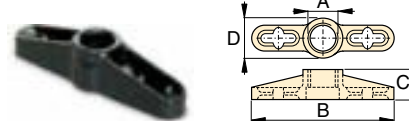

Tons	Model No.	A	B	C	D
2.5	A558	1 1/2"-16 UN	7.75	1.56	1.75
5.0	A132	2 1/4"-14 UN	12.12	2.50	3.12
12.5	A238	3 5/16"-12 UN	17.75	4.03	4.93

17 Double Chain Plate

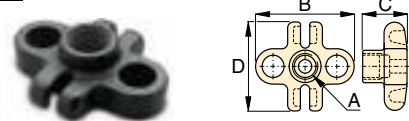

Tons	Model No.	A	B	C	D
5.0	A5	1 1/4"-11 1/2 NPT	6.18	2.00	4.96

18 Chain with Hook



Tons	Model No.	Chain Length
2.5	A557	5 feet
5.0	A141	6 feet
12.5	A218	8 feet

Tubes, Connectors and Adaptors

19 Pipe Coupling

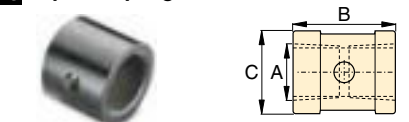

Tons	Model No.	A	B	C
2.5	A544	3/4"-14 NPT	1.69	1.31
5.0	A19	1 1/4"-11 1/2 NPT	1.94	2.15
12.5	A242	2"-11 1/2 NPT	3.50	3.25

20 Spreader

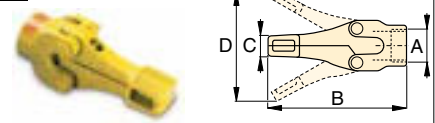

Tons	Model No.	A	B	C	D
1.0	WR5	—	8.78	0.50	3.70
1.0	A92	2 1/4"-14 UN	9.63	1.38	6.25

21 Lock Pin

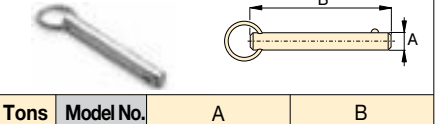

Tons	Model No.	A	B
2.5	MZ4013	0.25	2.38
5.0	A16	0.44	3.25

22 Lock-on Connector

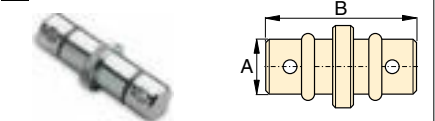

Tons	Model No.	A	B
2.5	MZ4007	0.75	3.12
5.0	MZ1050	1.31	5.00

23 Male Lock-on Adaptor

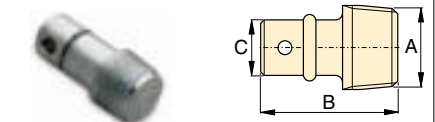

Tons	Model No.	A	B	C
2.5	MZ4008	3/4"-14 NPT	2.38	0.75
5.0	MZ1051	1 1/4"-11 1/2 NPT	3.56	1.31

24 Female Lock-on Adaptor

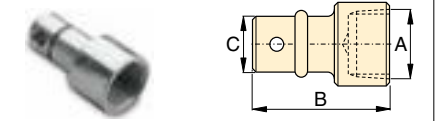

Tons	Model No.	A	B	C
2.5	MZ4009	3/4"-14 NPT	2.56	0.75
5.0	MZ1052	1 1/4"-11 1/2 NPT	3.81	1.31

25 Adjustable Extension

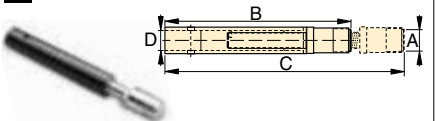

Tons	Model No.	A	B	C	D
5.0	A285	1 1/4"-11 1/2 NPT	13.20	17.37	1.30

26 Slip-Lock Extension

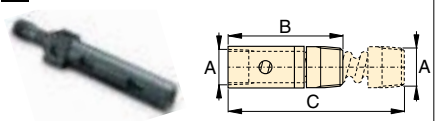

Tons	Model No.	A	B	C
2.5	A650	3/4"-14 NPT	7.88	14.37

▼ Shown: SP35S



Much Faster than Drilling...



Tool Kit SPK10

Included with all 35-ton punches, this tool kit is used to remove and install the punch into the head.

Can be ordered as a replacement under model number **SPK10**.



Ordering Information

The 35-ton hydraulic punch may be ordered by itself or as a set, including an electric, air or hand pump.

Please refer to the Quick Selection Chart information on next page.

A punch and die may also be ordered as a matched set.

- 0.50" thick mild steel maximum capacity
- Round, oblong and square punches and dies are available to solve your punching applications
- Long life Enerpac single-acting, spring return design
- Durable case keeps tools and dies together and provides for easy carrying and storage
- CR400 female coupler included

▼ STANDARD PUNCH AND DIE SETS SELECTION CHART

Hole Shape	Imperial*		Metric*	
	Hole Size (in)	Bolt Size (in)	Hole Size (mm)	Bolt Size (mm)
●	0.31	1/4	7.9	–
●	0.38	5/16	9.5	M8
●	0.44	3/8	11.1	M10
●	0.53	7/16	13.5	M12
●	0.56	1/2	14.3	–
●	0.69	5/8	17.5	M16
●	0.78	–	19.8	M18
●	0.81	3/4	20.6	–
■	0.31	1/4	7.9	–
■	0.38	5/16	9.5	M8
■	0.44	3/8	11.1	M10
■	0.50	7/16	12.7	M12
●	0.31 x 0.75	1/4	7.9 x 19	–
●	0.38 x 0.75	5/16	9.5 x 19	M8
●	0.44 x 0.75	3/8	11.1 x 19	M10
●	0.50 x 0.75	7/16	12.7 x 19	M12

* Material thickness should **not** exceed hole diameter.

▼ SP-Series, Lightweight Hydraulic Punch – much faster than drilling.



Single-Acting, Spring Return Hydraulic Punch

▼ QUICK SELECTION CHART

* 	Included				Model Number	Weight (lbs)
	Punch and Die Set	Pump	Pump Type ¹⁾	Hose		
SP35	-	-	-	-	SP35	35
SP35	Standard**	-	-	-	SP35S	40
SP35	Standard**	PUD1100B	E	HC7206	SP35SP	70
SP35	Metric***	-	-	-	MSP351	40
SP35	Standard**	P392	H	HC7206	STP35H ²⁾	55
SP35	Standard**	PATG1102N	A	HC7206	STP35A ²⁾	63

* Punch oil capacity: 4.58 in³

Includes the following punch and die sets:

** SPD438, SPD688, SPD563 and SPD813

*** SPD375, SPD531, SPD438 and SPD688

¹⁾ E = Electric; H = Hand; A = Air operated

²⁾ STP35H and STP35A include the GP10S gauge and GA2 gauge adapter.

**SP,
MSP,
STP
Series**



Capacity:

35 tons

Hole Sizes:

0.31 - 0.81 inch

Maximum Operating Pressure:

10,000 psi

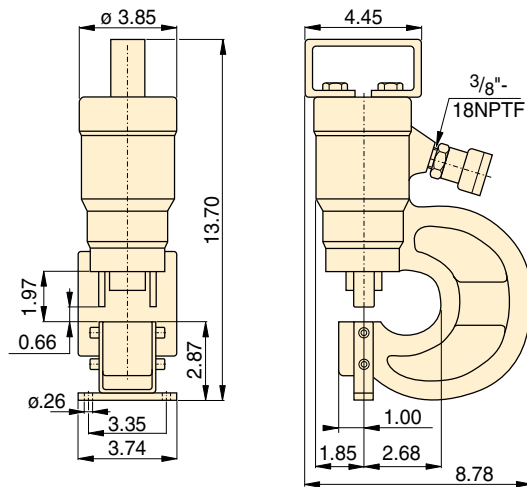

CAUTION!

Chart below is for reference only! Maximum allowable material thickness to be punched varies with set wear.



CAUTION!

Material thickness should not exceed hole diameter.

Standard Punch & Die Set 	Maximum Allowable Material Thickness To Be Punched (in) (Material thickness should not exceed hole diameter.)											
	Model No.	1)	2)	3)	4)	5)	6)	7)	8)	9)	10)	11)
SPD313	0.31	0.31	0.25	0.25	0.25	0.25	0.13	0.19	0.25	0.25	0.25	0.25
SPD375	0.38	0.38	0.31	0.31	0.31	0.31	0.19	0.25	0.31	0.31	0.31	0.31
SPD438	0.44	0.44	0.38	0.38	0.38	0.31	0.19	0.31	0.31	0.31	0.31	0.31
SPD531	0.50	0.50	0.44	0.44	0.44	0.38	0.25	0.31	0.38	0.38	0.38	0.38
SPD563	0.50	0.50	0.50	0.44	0.50	0.44	0.25	0.38	0.44	0.44	0.44	0.44
SPD688	0.50	0.50	0.50	0.44	0.50	0.40	0.25	0.31	0.40	0.40	0.40	0.40
SPD781	0.50	0.50	0.50	0.44	0.50	0.38	0.25	0.31	0.38	0.39	0.38	0.38
SPD813	0.50	0.50	0.50	0.44	0.50	0.31	0.19	0.31	0.31	0.31	0.31	0.31
SPD458	0.31	0.31	0.25	0.25	0.25	0.25	0.13	0.19	0.25	0.25	0.25	0.25
SPD549	0.38	0.38	0.31	0.31	0.31	0.31	0.19	0.25	0.31	0.31	0.31	0.31
SPD639	0.44	0.44	0.38	0.38	0.38	0.31	0.19	0.31	0.31	0.31	0.31	0.31
SPD728	0.50	0.50	0.44	0.44	0.44	0.38	0.25	0.31	0.38	0.38	0.34	0.34
SPD106	0.31	0.31	0.25	0.25	0.25	0.25	0.13	0.19	0.25	0.25	0.25	0.25
SPD125	0.38	0.38	0.31	0.31	0.31	0.31	0.19	0.25	0.31	0.31	0.31	0.31
SPD188	0.44	0.44	0.38	0.38	0.38	0.31	0.19	0.31	0.31	0.31	0.31	0.31
SPD250	0.50	0.50	0.44	0.44	0.44	0.38	0.25	0.31	0.38	0.38	0.38	0.38

Steel Qualities (see table):

- 1) Mild A-7
- 2) Boiler Plate
- 3) Structural A-36
- 4) Struct Corten (ASTM A242)
- 5) Cold Rolled C-1018
- 6) Hot Rolled C-1050
- 7) Hot Rolled C-1095
- 8) Hot Rolled C-1095 Annealed
- 9) Stainless Annealed
- 10) Stainless 304 Hot Rolled
- 11) Stainless 316 Cold Rolled

▼ Shown: SP50100



- Available as a complete set including electric pump and hoses
- Double-acting cylinder design for fast cycle times
- Punch and die changeover tools included
- Lifting handle for easy carrying
- Adjustable power stripper prevents movement of the metal during stripping
- CR400 female couplers included

Cuts the Time Spent Forming Holes



Depth Stop

For simplified repetitive punching applications an adjustable Depth Stop is available.

Order model number: **SP110**.



Foot Mounting Kit

A foot mounting kit for easy mounting of the 50-ton punch to workbench or fixture is available.

Please order: **SP120**.

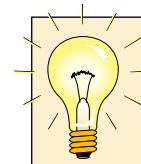

Ordering Information

The 50-ton Hydraulic Punch may be ordered by itself or as a set with an electric pump. A punch and die may be ordered as a matched set. Please refer to the selection chart information.



◀ Save time using this 50-ton Enerpac Punch.

▼ Shown below is the 50-ton punch with SP120 and SP110 assembled.



50-Ton Hydraulic Punch

▼ QUICK SELECTION CHART PUNCH SETS

Model Number Punch*	Included			Set Model Number	Weight (lbs)
	Punch & Die Sets 	Pump	Hose (2x)		
SP50	All**	-	-	SP50100	255
SP50	All**	ZE4410SBN	HC7206	SP5000	384

* Punch Oil Capacity:
Advance: 17 in³
Retract: 14 in³

** All standard sets from chart below.

SP Series



Capacity:

50 tons

Hole Sizes:

0.53 - 1.03 inches

Maximum Operating Pressure:

10,000 psi

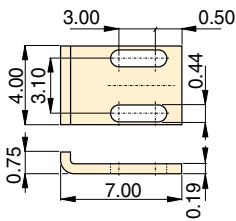

SP110

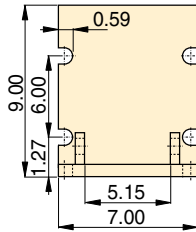

SP120

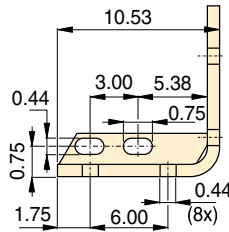

CAUTION!

Material thickness should not exceed hole diameter.



CAUTION!

Chart below is for reference only! Maximum allowable material thickness to be punched varies with set wear.

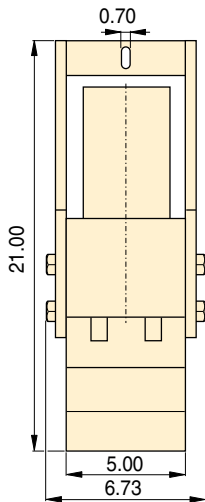

SP50

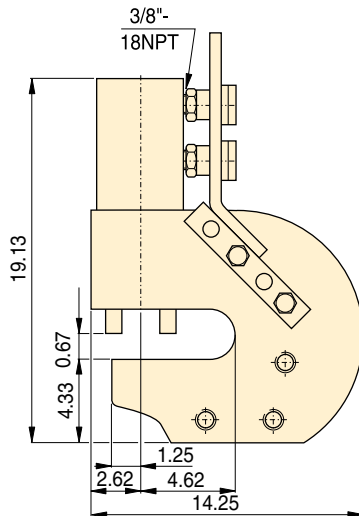

Steel Qualities (see table below):

- 1) Mild A-7
- 2) Boiler Plate
- 3) Structural A-36
- 4) Struct Corten (ASTM A242)
- 5) Cold Rolled C-1018
- 6) Hot Rolled C-1050
- 7) Hot Rolled C-1095
- 8) Hot Rolled C-1095 Annealed
- 9) Stainless Annealed
- 10) Stainless 304 Hot Rolled
- 11) Stainless 316 Cold Rolled

▼ STANDARD PUNCH AND DIE SELECTION CHART

Hole Shape	Hole Size (in)	Bolt Size (in)	Standard Punch and Die Set  Model Numbers	Maximum Allowable Material Thickness To Be Punched (in)										
				1)	2)	3)	4)	5)	6)	7)	8)	9)	10)	11)
●	0.53	1/2	SP150	0.53	0.53	0.53	0.53	0.53	0.49	0.32	0.40	0.49	0.49	0.49
●	0.66	5/8	SP170	0.56	0.56	0.56	0.50	0.56	0.51	0.32	0.40	0.51	0.51	0.51
●	0.78	3/4	SP190	0.56	0.56	0.56	0.50	0.56	0.49	0.32	0.40	0.49	0.50	0.49
●	0.91	7/8	SP121	0.56	0.56	0.56	0.50	0.56	0.35	0.22	0.35	0.35	0.35	0.35
●	1.03	1	SP123	0.56	0.56	0.56	0.44	0.56	0.31	0.19	0.31	0.31	0.31	0.31

▼ Shown: LWC16, LW16 with SB2 and optional LWB1



LW Series

Minimum Clearance:
0.39 inches

Maximum Lift Height:
2.02* - 2.72* inches

Maximum Force:
16 tons

Maximum Operating Pressure:
10,000 psi

* Using LWB1



Portable Hydraulic Toolbox

Tool Box set includes hand pump, gauge, adaptor assembly, hose and coupler.

Page: 65



Split-Flow Manifolds

Split Flow Valves to control two or four lifting wedges simultaneously (LW16 only).

AM21 with 3 ports 3/8" NPTF.
AM41 with 5 ports 3/8" NPTF.

Page: 152

- Minimized access gap for greater accessibility on applications with limited insertion space
- Secure, stable lifting and lowering motion with no slippage
- Single-acting spring return cylinder allows for automatic, mechanical retraction
- Integrated hand pump offers greater maneuverability (LWC16 only)
- Includes safety block SB2

Portable Hydraulic Toolbox Set SWR5PGH

Tool box includes P392 hand pump, gauge adaptor assembly, hose and WR5.

▼ The LW-Series is the ideal solution for lifting heavy equipment with minimum floor clearance.

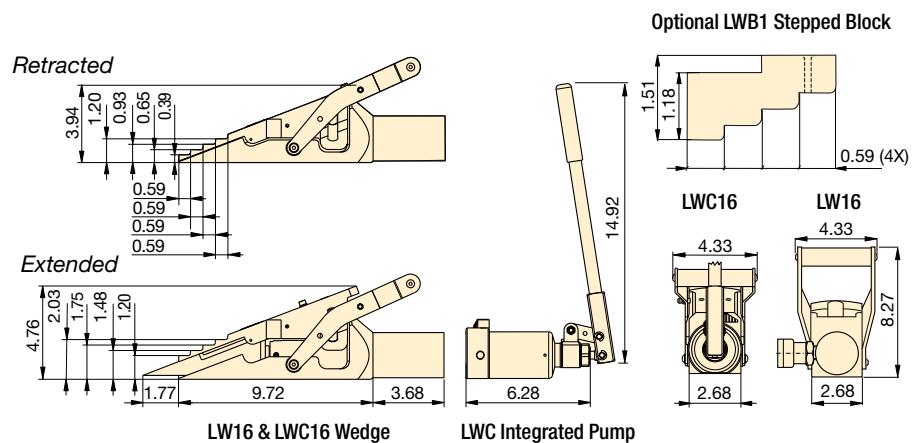

Max. Lifting Force (ton)	Model No.	Minimum Clearance Gap (in)	Max. Lift per Stage (in)	Max. Lifting Height (in)	Max. Lifting Height using Stepped Block (in)	Oil Capacity (in ³)	Wt. (lbs)	Pump Power Source
16	LW16*	0.39	0.83	2.02	2.72	4.75	15.4	External
	LWC16**					-	22.0	Integrated

* Includes SB2

** Includes SB2, LWB1, and carrying case

▼ Shown from left to right: SOH10-6, SOH23-6



- For lifting heavy equipment with minimum available access
- Remote operation of hydraulic pump enhances safety
- Low-height lifting toe
- Precision guided to reduce friction and isolate cylinder from side-loads
- Two extendable support feet provide extra stability
- Includes RC-Series cylinder with CR400 coupler

SOH Series

Lifting Capacity:

8.5 - 20 tons

Stroke:

5.39 - 6.18 inches

Toe Clearance:

0.79 - 1.18 inches

Maximum Operating Pressure:

10,000 psi



ER-Series Load Skates

In combination with the Enerpac Lifting Wedge we recommend Load Skates for moving heavy loads.

Page: 214



RSM Flat-Jac®

Low height, single acting spring-return cylinders are ideal for space restricted applications.

Page: 26

▼ Heavy transport using Load Skates. The machine is first lifted, using SOH-Series Enerpac Machine Lifts.

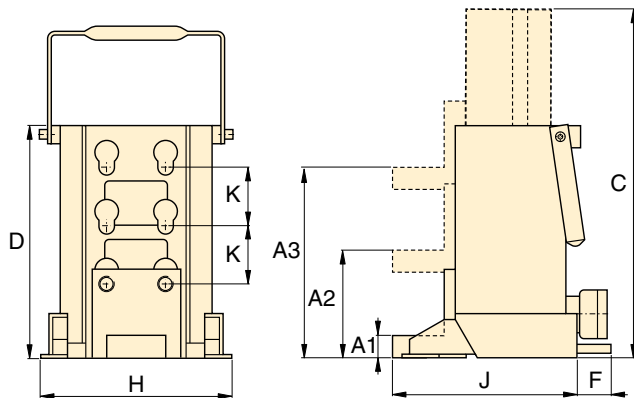

Capacity (ton)	Toe Clearance with Cylinder Retracted (in)			Stroke (in)	Model Number	Oil Capacity (in ³)	Dimensions (in)						Weight (lbs)
	Minimum A1	Central A2	Maximum A3				Total Ext. Height C	Total Body Height D	F	H	J	K	
8.5	0.79	3.74	6.69	5.39	SOH10-6	13.7	17.00	11.61	–	7.48	8.46	2.95	59.2
20	1.18	4.33	7.48	6.18	SOH23-6	32.0	18.58	12.40	2.56	10.24	9.84	3.15	99.2

▼ Shown: Set ERS20



Move Heavy Loads Easily and Safely

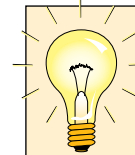

Sets (see table) include all components necessary to handle a variety of applications. Two **ELB1** link-up bars, two **ERH1** handles (34.4" long) and one **EMB1** metal box are included. Optional long handle **ERH2** (46.4") also available.

- Rugged and sturdy construction for long life
- Low profile construction for increased stability
- Low rolling-resistance allows for easy load movement
- Attachable load leveling plates and swivel turntables for turning corners



Lifting Wedge and Machine Lifts

To place the Load Skates, the load must first be lifted. This can be done easily and safely using Enerpac Lifting Wedge or Machine Lifts.

Page: 212

▼ Heavy transport using Load Skates. The machine is first lifted, using SOH-Series Enerpac Machine Lifts.



▼ Chemical tank transportation: The first inch(s) the load was lifted with an RCS-Series Low Height Cylinder and then moved onto load skates for transportation.



ER-Series, Chain Roller Load Skates

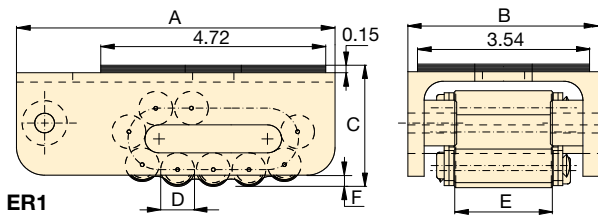

ER1

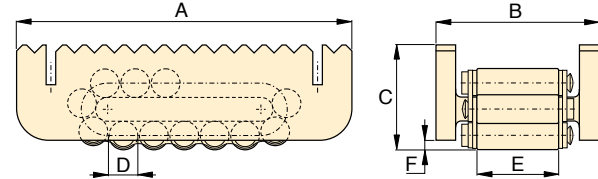

ER10, ER15, ER30

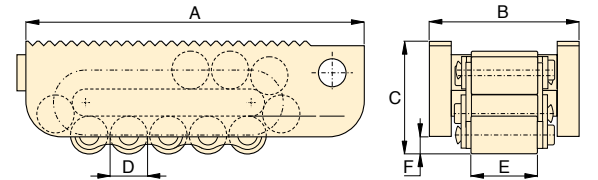

ER60, ER80

**ELP,
ER,
ES
Series**



Maximum Carrying Capacity:
80 tons

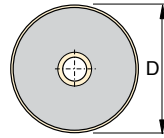

Turntable Swivel
ES1

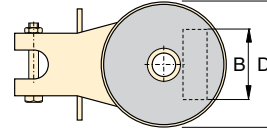

Turntable Swivel
ES10, ES15, ES30

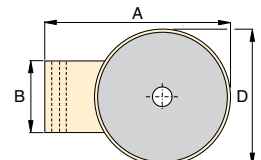

Turntable Swivel
ES60, ES80

Load Skates may be ordered separately or as a matched set.					
Set Capacity*	Set Model Number	Load Skates (4)	Turntable Swivels (2)	Leveling Plates (2)	Weight Including handles and metal box (lbs)
(tons)					
20	ERS20	ER10	ES10	ELP10	110
30	ERS30	ER15	ES15	ELP15	123
60	ERS60	ER30	ES30	ELP30	167

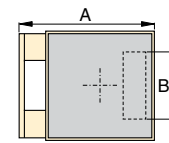

Leveling Plate
ELP10
ELP15
ELP30

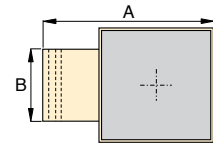

Leveling Plate
ELP60
ELP80

* Sets are designed to enable two skates to take full load for extra safety on uneven floor surfaces

	Capacity (ton)	Model Number	Dimensions (inch)						Contact Rolls per Skate	Rollers per Skate	Weight (lbs)
			A	B	C	D	E	F			
Load Skates ER1 ER10	1	ER1	6.69	3.94	2.56	0.71	2.00	0.24	4	11	8.4
	10	ER10	8.27	3.94	2.63	0.71	2.00	0.24	5	15	11.5
	15	ER15	8.69	4.45	2.95	0.94	2.38	0.39	4	13	16.0
	30	ER30	10.63	5.13	3.63	1.18	2.69	0.39	4	13	28.6
	60	ER60	15.00	6.63	4.94	1.65	3.00	0.63	4	13	70.4
Turntable Swivel ES1 ES10	1	ES1	8.15	-	1.02	3.54	-	-	-	-	2.4
	10	ES10	8.66	2.87	1.65	5.12	-	-	-	-	8.1
	15	ES15	8.66	3.39	1.65	5.12	-	-	-	-	8.1
	30	ES30	9.84	3.78	1.89	5.91	-	-	-	-	11.7
	60	ES60	10.83	4.49	2.40	7.48	-	-	-	-	30.1
Leveling Plate 	10	ELP10	5.87	2.87	1.65	4.72	-	-	-	-	8.1
	15	ELP15	5.87	3.39	1.65	4.72	-	-	-	-	8.1
	30	ELP30	7.01	3.78	1.89	5.12	-	-	-	-	11.6
	60	ELP60	10.63	4.49	2.40	7.09	-	-	-	-	30.4
	80	ELP80	13.78	5.04	2.40	7.87	-	-	-	-	41.4

▼ Shown: **CM16**



CM Series

Case Size:

0.67 - 16 cubic ft.

Protect your Equipment



Maintenance Sets

Enerpac Maintenance sets are a complete assortment of accessories matched to hydraulic powered tools. Using these sets allows you to quickly configure a unique tool to meet your most difficult jobs.

Built around the Enerpac lightweight hand pump, hose and cylinder, these sets enable you to push, pull, lift, press, straighten, spread and clamp with forces up to 12.5 tons.



Hydraulic Pullers

These hydraulic pullers eliminate time-consuming and unsafe hammering, heating or prying.

Damage to parts is minimized through the use of controlled hydraulic power.

- **Protect your equipment from dust, water, grease and dirt**
- **Reduce losses on the jobsite, maintenance area or shop**
- **Durable steel, painted with rust-resistant primer and finished in durable enamel**
- **Heavy-duty hinges and lifting handles**
- **Lockable**

▼ *When not storing the lifting system, this heavy-duty storage case doubles as a work station.*



Page: **183**

Case Size (ft ³)	Model Number	Interior Dimensions L x W x H (in)	Thickness (in)	Weight (lb)
0.67	CM6	23.5 x 7 x 8	0.035	15.4
1.13	CM1	24.5 x 11.1 x 6.5	0.035	17.6
4.50	CM4	30.6 x 17.9 x 13.9	0.059	35.3
7.50	CM7	47.6 x 15.2 x 18	0.074	125.7
16.00	CM16	47.9 x 23.9 x 21.9	0.059	121.3

Hydraulic Wedgie and Spread Cylinders

▼ Shown clockwise from top: **WR15, WR5, A92**



- Single-acting, spring return
- **WR15:** For long stroke spreading applications
- **WR5:** For use in very confined work areas
- **A92*:** Spreader attachment screws onto RC-Series 10-ton cylinders (except RC101)*

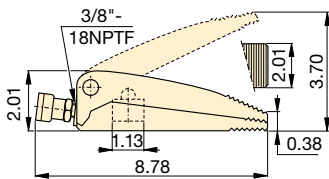

WR5

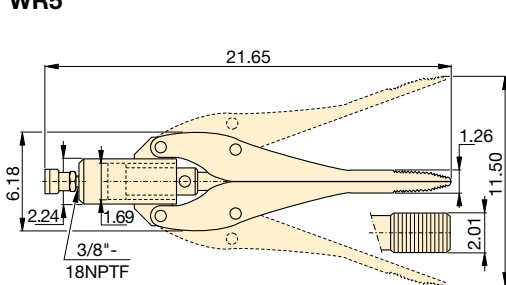

WR15

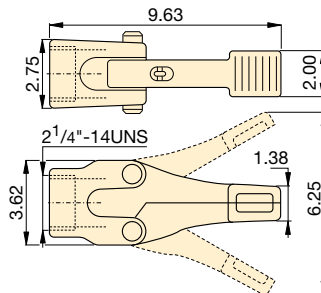

A92*

Spreader Capacity	Tip Clearance	Model Number	Maximum Spread	Cylinder Effective Area	Oil Capacity	Wt.
(ton)	(in)		(in)	(in ²)	(in ³)	(lbs)
1.00	0.50	WR5	3.70	1.00	0.61	5.0
0.75	1.26	WR15	11.50	2.25	3.91	25.0
1.00	1.38	A92*	6.25	—	—	8.0

* Maximum system pressure must be limited to half the rated pressure (5000 psi)

A, WR Series

Capacity:

0.75 - 1.00 ton

Tip Clearance:

0.50 - 1.38 inches

Maximum Spread Range:

3.70 - 11.50 inches

Maximum Operating Pressure:

10,000 psi



RC-Series TRIO Cylinders

10-ton RC-Series TRIO cylinders (except RC101) fit into A92 Spreader attachment.

Page: **6**



Best Match Hand Pump

To power your WR5 and WR15 the **P392** hand pump is an ideal choice.

Page: **86**



Portable Hydraulic Toolbox Set SWR5PGH

Tool box includes P392 hand pump, gauge adaptor assembly, hose and **WR5**.

Page: **65**

▼ A **WR5** Wedgie cylinder is used to loosen a bridge bearing.

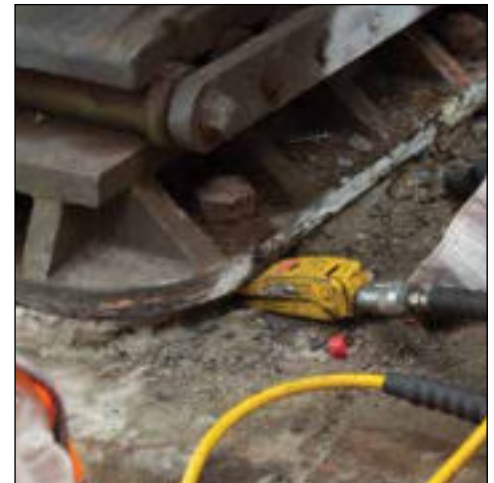

▼ Shown: **STB101H**



Quick, Safe and Wrinkle-free Bending



'One Shot' and 'Sweep'

One shot shoes give up to a 90° bend without resetting.

Sweep shoes are used where increased radii are required for multiple parallel pipe installations.

- Makes smooth, wrinkle-free bends
- Sets include cylinder, hose and manual, air or electric pump
- Sets are also available without hydraulics
- Bending shoes and bending frame are lightweight, heat-treated aluminum
- All sets include sturdy steel storage case
- All sets include BZ12091 angle indicator for accurate bending
- BZ12377 Shoe Lock Pin included in every set
- Eject-O-Matic™ benders (STB202 models) use a double-acting cylinder to eject pipe from the bending shoe

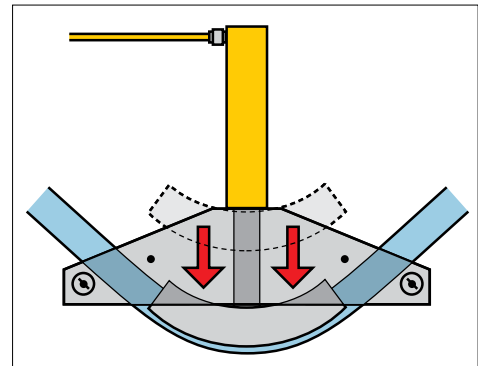

▲ Typical one shot bending operation.

▼ SELECTION CHART

Pipe Range		Set Model Number	Hand Pump*	Air Pump*	Electric Pump*	Cylinder*	Hose*	Steel Case*	Saddle	Weight (includes steel case)
One Shot	Sweep									
½ - 2	-	STB101X	-	-	-	-	-	CM4	A12	88
		STB101N	-	-	-	RC1010	HC7206	CM4	A12	105
		STB101H	P392	-	-	RC1010	HC7206	CM4	A12	114
		STB101A	-	PATG1102N	-	RC1010	HC7206	CM4	A12	119
		STB101B	-	-	PUJ1200B ²⁾	RC1010	HC7206	CM4	A12	127
1 - 2	2½ - 4	STB221X	-	-	-	-	-	CM7	A29	229
		STB221N	-	-	-	RC2510	HC7206	CM7	A29	263
		STB221H	P80	-	-	RC2510	HC7206	CM7	A29	286
1¼ - 4	-	STB202X ¹⁾	-	-	-	-	-	CM7	A29	316
		STB202N ¹⁾	-	-	-	RR3014	HC7206 (2x)	CM7	A29	383
		STB202B ¹⁾	-	-	ZU4408SB ²⁾	RR3014	HC7206 (2x)	CM7	A29	467

* See corresponding sections of this catalog for more detailed specifications.

¹⁾ Eject-O-Matic™ ²⁾ For 230 volt applications change the last digit of Set Model Number from "B" to "E".

Pipe Bender Sets

Nominal pipe size (outside dia.) (in)	Wall Thickness (in)	Schedule Pipe *	Pipe Bend Inside Radius (in)	STB101	STB221	STB202	One Shot Bending Shoe Model Number	Sweep Bending Shoe Model Number
				1/2 - 2 One Shot	1-2 One Shot	2 1/2 - 4 Sweep		
1/2 (0.840)	0.109	40	2 7/8	Yes	-	-	BZ12011	-
	0.147	80		Yes	-	-		
	0.187	160		WS	-	-		
	0.294	DEH		WS	-	-		
3/4 (1.050)	0.113	40	4	Yes	-	-	BZ12021	-
	0.154	80		Yes	-	-		
	0.218	160		WS	-	-		
	0.308	DEH		WS	-	-		
1 (1.315)	0.133	40	5 1/8	Yes	Yes	-	BZ12031	-
	0.179	80		Yes	Yes	-		
	0.250	160		WS	WS	-		
	0.358	DEH		-	WS	-		
1 1/4 (1.660)	0.140	40	6 7/8	Yes	Yes	Yes	BZ12041	-
	0.191	80		Yes	Yes	Yes		
	0.250	160		WS	WS	Yes		
	0.342	DEH		-	WS	WS		
1 1/2 (1.900)	0.145	40	7 5/8	Yes	Yes	Yes	BZ12051	-
	0.200	80		Yes	Yes	Yes		
	0.281	160		WS	WS	Yes		
	0.400	DEH		-	WS	WS		
2 (2.375)	0.154	40	8 5/8	Yes	Yes	Yes	BZ12061	-
	0.218	80		-	Yes	Yes		
	0.343	160		-	WS	Yes		
2 1/2 (2.875)	0.203	40	9 1/2	-	Yes	Yes	BZ12341	BZ12382
	0.276	80		-	WS	Yes		
	0.375	160		-	WS	Yes		
3 (3.500)	0.216	40	11 1/4	-	Yes	Yes	BZ12351	BZ12383
	0.300	80		-	WS	Yes		
3 1/2 (4.000)	0.226	40	15 1/2	-	Yes	Yes	BZ12391	BZ12384
	0.318	80		-	WS	Yes		
4 (4.500)	0.237	40	17 3/4	-	Yes	Yes	BZ12392	BZ12385
	0.337	80		-	-	Yes		

STB Series



Nominal Pipe Size:

0.5 - 4 inches

Maximum Bend Angle:

90°

Maximum Operating Pressure:

10,000 psi



* Schedule Pipe

All bender sets are designed to bend mild steel pipe. For other material please consult Enerpac.

- 40** = Standard;
- 80** = Extra Heavy;
- 160** = Double Extra Heavy;
- DEH** = Double Extra Heavy (slightly thicker than 160);
- WS** = Can be bent by using wider spacing for swivel shoes.

Frame Assembly	Pivot Pin**	Pivot Shoes**	One Shot or Sweep ³⁾ Bending Shoes included									Set Model Number	
			STB101	STB221	STB202	One Shot	Sweep	One Shot	One Shot	Sweep	One Shot		
BZ12371	BZ12375	BZ12071	BZ12011	BZ12021	BZ12031	BZ12041	BZ12051	BZ12061	-	-	STB101X		
												STB101N	
													STB101H
													STB101A
													STB101B
BZ12372	BZ12376	BZ13401	BZ12031	BZ12041	BZ12051	BZ12061	BZ12382 ³⁾	BZ12383 ³⁾	BZ12384 ³⁾	BZ12385 ³⁾	STB221X		
											STB221N		
												STB221H	
BZ12374	BZ12376	BZ13401	-	BZ12041	BZ12051	BZ12061	BZ12341	BZ12351	BZ12391	BZ12392	STB202X ¹⁾		
												STB202N ¹⁾	
												STB202B ¹⁾	

³⁾ Shoes are Sweep, all other shoes are One Shot.

** Sets include two pivot pins and two pivot shoes.

When you need to make cuts through heavy-duty bar, chain, cable and similar materials, look no further than Enerpac's broad range of cutters.

An extensive lineup of hydraulic, electric and manual cutters provides a quick, safe and cost-effective solution for technicians from construction, mining, manufacturing and many other industries.

Enerpac's cutters are built to handle industrial-grade materials on a daily basis. Like all Enerpac tools, each cutter is designed and built to last in tough working conditions for a safer, simpler and more productive workflow.

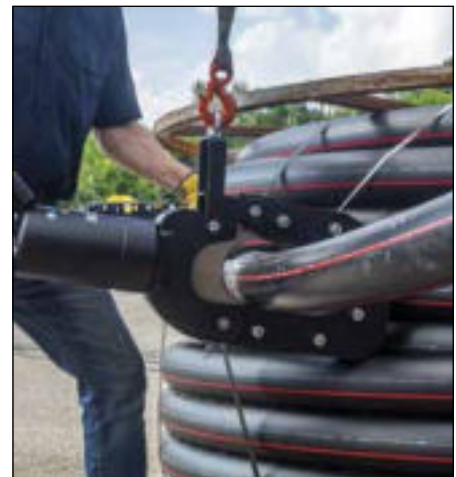

Cutter Type		Maximum Tool Capability*	Series		Power Source	Page
Bar Cutters		2.04" (Maximum Material Cutting Diameter)	EB		Hydraulic, Electric, Cordless	222 ▶
Decommissioning Cutters		6.69" (Maximum Blade Aperture)	EDC		Hydraulic	226 ▶
Flat Bar Cutters		2.75" x 0.59" (Maximum Material Cutting Height and Width)	EFB		Electric	227 ▶
Chain Cutters		1.25" (Maximum Link Cutting Diameter)	ECC		Electric	228 ▶
Wire and Cable Cutters		7.09" (Maximum Material Cutting Diameter)	EWC		Hydraulic, Electric	230 ▶
Cutter / Spreader Combination Tools		11.81" (Maximum Blade Aperture)	ECS		Electric	233 ▶
Hydraulic Cutterheads		4.00" (Maximum Material Cutting Diameter)	WHC WHR STC		Hydraulic	234 ▶
Self-Contained Hydraulic Cutters		3.38" (Maximum Material Cutting Diameter)	WMC		Manual	235 ▶
ZE-Series Pumps and Accessories		1.5 - 7.5 hp	EBH EWCH		Electric	236 ▶
ZC, ZE-Series Pumps and Accessories		1.4 - 7.5 hp	EDCH		Electric, Cordless	237 ▶

* Actual cutting capabilities may vary depending on material being cut.

▼ Shown left to right: EBC20B, EBH30, EBE22B



Your Fast, Safe and Simple Solution for Cutting Metal Bar



Internal Mechanics

EBH-Series: Cylinder is driven by an external Enerpac pump

EBE, EBC-Series: Cylinder is driven by a radial pump powered by an electric motor.



Typical Bar Cutting Applications

- Commercial and residential construction
- Concrete and masonry
- Metal fabrication
- Industrial manufacturing

Productivity

- A broad range of hydraulic and electric tools quickly and easily cut through heavy-duty bar
- Highly durable, long-lasting blades outlast angle grinder or saw blades

Safety

- Controlled cutting process enhances user safety compared with use of cut-off blades
- Minimal spark risk compared to torching, grinding and sawing methods
- Cutters produce minimal vibration, helping prevent HAVS (Hand Arm Vibration Syndrome)

▼ Enerpac's bar cutters are built to handle tough cutting applications.



EBH-Series Hydraulic Bar Cutters



EBH-Series Hydraulic Bar Cutters

EBH-Series Hydraulic Bar Cutters are driven by a specialized external hydraulic pump for optimal power

and a higher duty cycle compared with other cutter types.

These cutters are ideal for use in production or manufacturing facilities with demanding, high-volume cutting applications.

- ① Highly durable blades maintain effectiveness throughout rigorous use
- ② Safety guard helps protect hands from injury
- ③ Heavy-duty cutting head provides a longer operational life
- ④ Lifting handle enables easier positioning and transport
- ⑤ Double-acting cylinder with advance and retract buttons improves control and reduces jamming
- ⑥ External hydraulic pump helps keep the tool cool, improving operational time (pump, hose, and pump coupler sold separately)

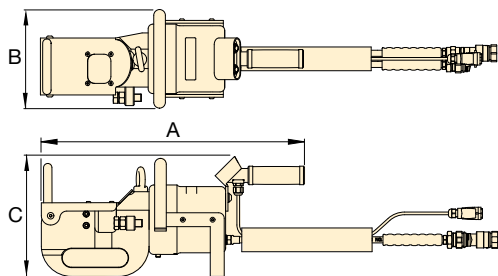

Drawings are for guidance purposes only, exact tool configurations vary by model.

Maximum Material Diameter* (in)	Model Number	Maximum Material Tensile Strength* (psi)	Maximum Material Hardness* (HRc)	Maximum Cutting Force (tons)	Maximum Hydraulic Operating Pressure (psi)	Dimensions (in)			Weight (lbs)	Replacement Blade Kit Number
						A	B	C		
1.18	EBH30	87,000	43	50	10,000	18.9	7.2	8.7	46	EBH3001K
1.38	EBH35	89,900	43	68	10,000	22.3	8.4	10.2	106	EBH3501K
2.04	EBH52	72,500	43	121	10,000	30.1	10.39	12.2	299	EBH5201K

* Maximum material properties indicated refer to the material to be cut.

EBH Series



Maximum Material Hardness:

43 HRc

Maximum Material Diameter:

1.18 - 2.04 inches

Maximum Operating Pressure:

10,000 psi



Pumps and Accessories

The EBH-Series Cutters are designed to work with specialized ZE4 and ZE6-Series pumps.

Pump models vary by voltage type. The pump and hose are sold separately. Both are required for the system to function. For complete details on required pumps and accessories:

Page: **236**



Optional gauges and accessories may be used to monitor pressure in the hydraulic circuit. Enerpac recommends **Gauge Kit GKHC** for use with Enerpac hydraulic cutters.



EBE-Series Electric Bar Cutters

The versatile EBE-Series Electric Bar Cutters

quickly cut through heavy-duty bar up to one inch (26 mm) in diameter without the need for an external hydraulic

pump. Their compact size and low weight enable them to be easily transported and used wherever an external power source is available.

EBE Series



Maximum Material Hardness:

43 HRC

Maximum Material Diameter:

0.87 - 1.02 inches

Voltage*:

120 and 230 Volts

* ETL certification applies to 120V tools only

- ① Highly durable blades maintain effectiveness throughout rigorous use
- ② Safety guard helps protect hands from injury
- ③ Heavy-duty cutting head provides a longer operational life
- ④ Lifting handle enables easy positioning and transport
- ⑤ Piston-release mechanism allows blade to be reset, reducing jamming and providing a controlled cutting process



EBE22

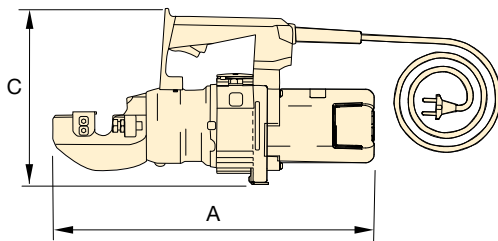

EBE26

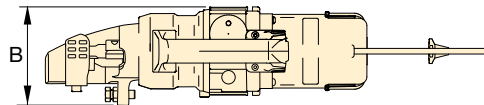
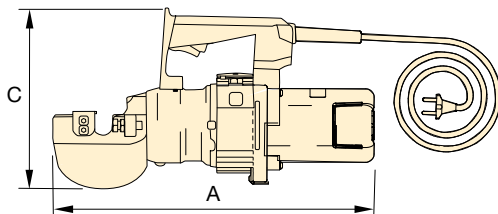

Voltage: (Model No. ending with suffix)

B = 120V, 60 Hz (with American-style NEMA 1-15 plug)

E = 230V, 50 Hz (with European-style SCHUKO plug)

Maximum Material Diameter* (in)	Power Specifications				Model Number	Maximum Material Tensile Strength* (psi)	Maximum Material Hardness* (HRC)	Maximum Cutting Force (tons)	Dimensions (in)			Cord Length (ft)	Wt. (lbs)	Replacement Blade Kit Number
	Volts	Hz	Amps	Watts					A	B	C			
0.87	120	60	11	1300	EBE22B	94,275	43	25.1	18.1	5.5	9.8	6	29	EBE2201K
0.87	230	50	6.8	1400	EBE22E	94,275	43	25.1	18.1	5.5	9.8	10	29	EBE2201K
1.02	120	60	11	1300	EBE26B	94,275	43	37	18.4	5.5	10.2	6	35	EBE2601K
1.02	230	50	6.8	1400	EBE26E	94,275	43	37	18.4	5.5	10.2	10	35	EBE2601K

* Maximum material properties indicated refer to the material to be cut.

EBC-Series Cordless Bar Cutters



EBC-Series Cordless Bar Cutters

The highly portable EBC-Series Cordless Bar Cutters quickly and easily slice through up to number 6 rebar, or similar metal bar up to 0.79" (20mm) in diameter.

A powerful 20V Lithium-ion battery provides mobility and long lasting performance, making these tools the perfect go-to solution for the jobsite, including remote locations, or anywhere an external power source is not available.

- ① Highly durable blades maintain effectiveness throughout rigorous use
- ② Safety guard helps protect hands from injury
- ③ Highly durable cutting head can be rotated 360 degrees to aid in the positioning of the blades on the application.
- ④ Lifting handle enables easy positioning and transport
- ⑤ Piston-release mechanism allows blade to be reset, providing a controlled cutting process and reducing jamming
- ⑥ Powerful 20V battery provides high performance and complete mobility



Dimensions shown in inches.

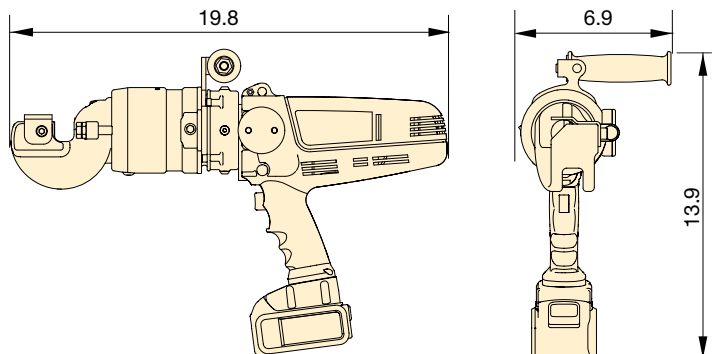

EBC Series



Maximum Material Hardness:

43 HRC

Maximum Material Diameter:

0.79 inches

Battery:

12 and 18 Volts

* ETL certification applies to 120V tools only



Batteries and Chargers

EBC-Series Cutters come standard with two DeWALT® TM 18V-5Ah Lithium-ion batteries and one DeWALT® TM 12V and 18V charger. Additional batteries and chargers sold separately.

EBC-Series Cutters work with DeWALT® 18V MAX® batteries. DeWALT® is a registered trademark of DEWALT Industrial Tool Co., which has not manufactured, licensed, approved, or endorsed this cutter product.

EBC-Series Replacement Parts

To order replacement parts, use one of the model numbers shown below.

For Cutter Model No.	DeWALT® Lithium-ion Battery	Li-ion Battery Charger 12V and 20V
EBC20B	B205	BC1220B
EBC20E	B185	BC1220E

Charger Voltage: (Model No. ending with suffix)

- B = 120V, 60 Hz (with American-style NEMA 1-15 plug)
- E = 230V, 50 Hz (with European-style SCHUKO plug)

Maximum Material Diameter*	Power Specifications			Model Number**	Maximum Material Tensile Strength*	Maximum Material Hardness*	Maximum Cutting Force	Weight (without battery)	Replacement Blade Kit Number
	Battery Input Voltage (volts)	Amps	Watts						
0.79 (in)	18-20	46	830	EBC20B	94,275 (psi)	43 (HRC)	21.2 (tons)	19.2 (lbs)	EBC2001K
0.79	18-20	46	830	EBC20E	94,275	43	21.2	19.2	EBC2001K

* Maximum material properties indicated refer to the material to be cut.

** To order an EBC-Series Cutter without batteries or a charger, remove the "B" or "E" from the Model Number, e.g. "EBC20"

▼ Shown: EDCH130



EDCH Series



Maximum Material Hardness:

41 HRc

Maximum Blade Aperture:

5.12 – 6.69 inches

Maximum Operating Pressure:

10,000 psi



Pumps and Accessories

The EDCH-Series Cutters are designed to work with specialized ZC3, ZE4 and ZE6-Series pumps.

The pump and hose are sold separately. Both are required for the system to function. See page 237 for complete details on required pumps and accessories.

Page: **237**

Productivity

- **Powerful jaws and an exceptionally large blade aperture enable use on a large variety of applications including metal tubes, communication cables, profiles and similar materials***
- **Multiple pump options provide power, speed and mobility for all your applications**

Safety

- **Minimal spark risk compared with torching, grinding and sawing methods**
- **Cutters produce minimal vibration, helping prevent HAVS (Hand Arm Vibration Syndrome)**

* NOTE: Do not use to cut wire rope. Use instead the wire and rope cutter, page 232.



Optional gauges and accessories may be used to monitor pressure in the hydraulic circuit. Enerpac recommends **Gauge Kit GKHC** for use with Enerpac hydraulic cutters.



- ① Durable blades maintain efficiency throughout rigorous use
- ② Double-acting steel piston and cylinder improve robustness and control
- ③ Control knob immediately stops the tool when released, improving operator safety
- ④ External hydraulic pump helps keep tool cooler and working longer (pump, hose, and pump coupler sold separately)

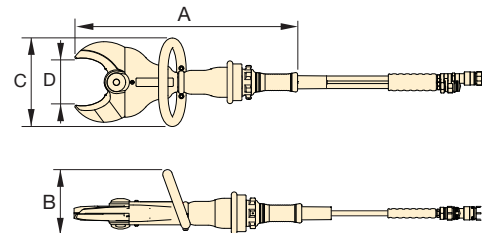

Maximum Blade Aperture (in)	Model Number	Maximum Material Tensile Strength* (psi)	Maximum Material Hardness* (HRc)	Maximum Hydraulic Operating Pressure (psi)	Dimensions (in)				Weight (lbs)	Replacement Blade Kit Number
					A	B	C	D		
5.12	EDCH130	94,275	41	10,000	23.2	6.7	9.2	5.1	25.4	EDCH13001K
5.70	EDCH145	94,275	41	10,000	27.0	8.1	9.7	5.7	37.3	EDCH14501K
6.69	EDCH170	94,275	41	10,000	28.9	6.8	9.8	6.7	53.4	EDCH17001K

* Maximum material properties indicated refer to the material to be cut.

Electric Flat Bar Cutters

▼ Shown: EFBE5017B



EFBE
Series



Maximum Material Hardness:

33 HRC

Maximum Material Dimensions:

1.96 x 0.67 – 2.75 x 0.59 in.

Voltage*:

120 and 230 volts

* ETL certification applies to 120V tools only

Productivity

- Cut through high-tensile flat bar in seconds
- Highly durable, long-lasting blades offer increased longevity and less down time

Safety

- Controlled cutting process enhances operator safety
- Minimal spark risk compared with torching, grinding and sawing methods



Replacement Blade Kits

To order replacement parts use one of the model numbers shown below.

For Cutter Model Number	Order Blade Kit Number
EFBE5017B	EFBE501701K
EFBE5017E	EFBE501701K
EFBE7015B	EFBE701501K
EFBE7015E	EFBE701501K



- ① Highly durable blades cut through flat bar, maintaining effectiveness throughout rigorous use
- ② Heavy-duty cutting head provides a longer operational life
- ③ Robust handle enables easy positioning and transport
- ④ Piston-release mechanism allows blade to be retracted, providing a controlled cutting process and reducing jamming

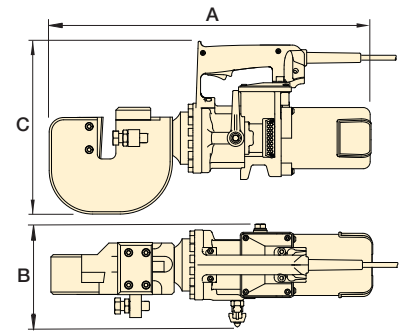

Voltage: (Model No. ending with suffix)

B = 120V, 60 Hz (with American-style NEMA 1-15 plug)

E = 230V, 50 Hz (with European-style SCHUKO plug)

Max. Material Dimensions* (in)		Power Specifications				Model Number	Maximum Material Tensile Strength* (psi)	Maximum Material Hardness* (HRC)	Maximum Cutting Force (tons)	Cord Length (ft)	Dimensions (in)			Wt. (lbs)
Height	Width	Volts	Hz	Amps	Watts						A	B	C	
1.96	0.67	120	60	11.0	1300	EFBE5017B	65,267	33	29.8	6	19.0	6.9	10.7	46
1.96	0.67	230	50	6.8	1400	EFBE5017E	65,267	33	29.8	10	19.0	6.9	10.7	46
2.75	0.59	120	60	11.0	1300	EFBE7015B	65,267	33	29.8	6	21.9	6.9	11.7	66
2.75	0.59	230	50	6.8	1400	EFBE7015E	65,267	33	29.8	10	21.9	6.9	11.7	66

* Maximum material properties indicated refer to the material to be cut.

▼ Shown: ECCE32B-Series Chain Cutter



Your Simple Solution for Cutting High-Strength Industrial Chain



Internal Mechanics

ECCE-Series: Cylinder is driven by a radial pump powered by an electric motor.



Typical Chain Cutting Applications

- Chain manufacturing
- Mining
- Rigging / material handling for transport
- Oil and gas
- Marine

Productivity

- Quickly cut through heavy-duty chain links with minimal effort
- Highly durable blades outlast angle grinder or saw blades

Safety

- Controlled cutting process behind a protective shield enhances safety
- Precisely cut only selected link, helping prevent damage to adjacent links and weakening of chain
- Minimal spark risk compared to torching, grinding and sawing methods
- Cutters produce minimal vibration, helping prevent HAVS (Hand Arm Vibration Syndrome)



◀ Cut through chain links with ease using Enerpac's chain cutters.

ECCE-Series Electric Chain Cutters



ECCE-Series Electric Chain Cutters

ECCE-Series Electric Chain Cutters are ideal for applications where safety is paramount. Unlike other cutting methods, Enerpac's chain cutters precisely cut selected chain links behind an enclosed, transparent safety guard.

This not only protects the operator's hands, it also helps prevent damage to adjacent links, which often results from using alternative cutting methods like torches or cut-off tools.

- ① Highly durable blades cut through heavy-duty chain, maintaining effectiveness throughout rigorous use
- ② Transparent safety guard protects hands and allows continuous monitoring for better management of cutting process
- ③ Heavy-duty cutting head provides a longer operational life
- ④ Lifting handle and eyebolt enable easy positioning and transport

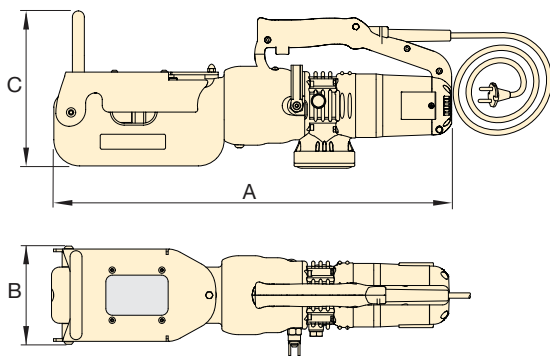
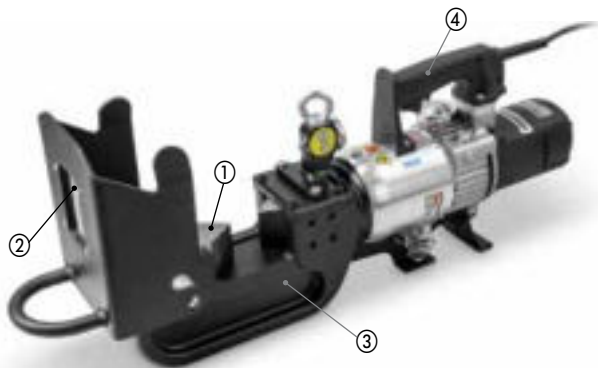

Voltage: (Model No. ending with suffix)

- B** = 120V, 60 Hz (with American-style NEMA 1-15 plug)
- E** = 230V, 50 Hz (with European-style SCHUKO plug)

ECCE Series



Maximum Material Hardness:

46 HRc

Maximum Material Diameter:

1.25 inches

Maximum Grade Chain:

100

Voltage*:

120 and 230 volts

* ETL certification applies to 120V tools only

Maximum Material Diameter ¹⁾²⁾ (in)			Power Specifications				Model Number	Maximum Material Hardness ¹⁾ (HRc)	Maximum Cutting Force (tons)	Dimensions (in)			Cord Length (ft)	Wt. (lbs)	Replacement Blade Kit Number
Grade 70	Grade 80	Grade 100	Volts	Hz	Amps	Watts				A	B	C			
1.00	1.00	0.5	120	60	10.0	1200	ECCE26B	46	35.1	23.6	6.0	9.3	6	55	ECCE2601K
1.00	1.00	0.5	230	50	5.3	1100	ECCE26E	46	35.1	23.6	6.0	9.3	10	55	ECCE2601K
1.25	1.00	0.75	120	60	11.0	1300	ECCE32B	46	52.9	27.5	7.5	12.6	6	106	ECCE3201K
1.25	1.00	0.75	230	50	6.8	1400	ECCE32E	46	52.9	27.5	7.5	12.6	10	106	ECCE3201K

¹⁾ Cutting larger chains or those of a grade higher than those recommended will result in increased wear, and may damage the tool.

²⁾ All links over 1/2" must be cut in two passes, with each pass cutting one side of the link.

▼ Shown left to right: EWCH90 and EWCE55B



The Quick and Clean Way to Cut Cable and Wire Rope

Productivity

- A broad range of hydraulic and electric tools quickly and easily cut through cable and wire rope

Safety

- Controlled cutting process enhances operator safety
- Minimal spark risk compared with torching, grinding and sawing methods
- Cutters produce minimal vibration, helping prevent HAVS (Hand Arm Vibration Syndrome)



Internal Mechanics

EWCH-Series: Cylinder is driven by an external Enerpac pump.

EWCE-Series: Cylinder is driven by a radial pump powered by an electric motor



Typical Wire and Cable Cutting Applications

- Telecommunications
- Electrical installation and maintenance
- Power generation and transmission
- Shipbuilding

▼ Guillotine-style blades make quick work of electrical cables and wire rope.



EWCH-Series Hydraulic Wire and Cable Cutters



EWCH-Series Hydraulic Wire and Cable Cutters

EWCH-Series Hydraulic Wire and Cable Cutters are ideal for use in production facilities where demanding, high-volume cutting applications are often encountered.

Each tool is driven by a specialized external hydraulic pump, which provides greater cutting force and allows for higher duty cycles compared with other cutter types.

- ① Guillotine-style blades maintain effectiveness throughout rigorous use
- ② Cutting head can be opened and closed to help position material to be cut
- ③ Eyebolt facilitates easy lifting
- ④ Double-acting cylinder with advance and retract buttons improves control and reduces jamming
- ⑤ External hydraulic pump helps keep tool cooler and working longer (pump, hose, and pump coupler sold separately)



EWCH180

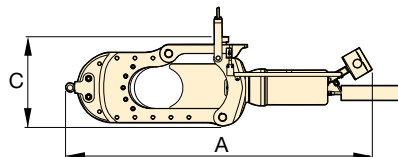
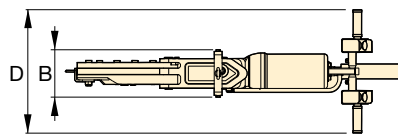

EWCH90

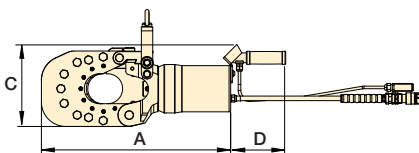
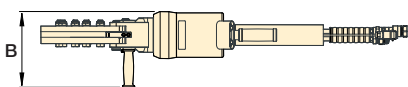

EWCH140

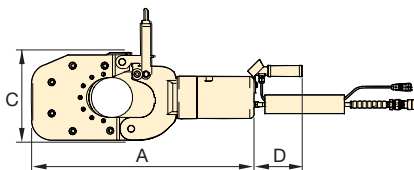
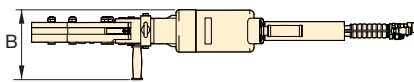

EWCH Series



Maximum Material Hardness (Cable):

43 HRc

Maximum Material Diameter:

3.54 - 7.09 inches

Maximum Operating Pressure:

10,000 psi



Pumps and Accessories

The EWCH-Series Cutters are designed to work with specialized ZE6-Series pumps.

The pump and hose are sold separately. Both are required for the system to function. See page 236 for complete details on required pumps and accessories.

Page: 236



Optional gauges and accessories may be used to monitor pressure in the hydraulic circuit. Enerpac recommends **Gauge Kit GKHC** for use with Enerpac hydraulic cutters.

Maximum Material Diameter* (in)	Model Number	Maximum Material Tensile Strength* (psi)	Maximum Material Hardness* (HRc)	Maximum Cutting Force (tons)	Maximum Hydraulic Operating Pressure (psi)	Dimensions (in)				Wt. (lbs)	Replacement Blade Kit Number
						A	B	C	D		
3.54	EWCH90	94,275	43	61.8	10,000	22.9	11.1	9.9	6.7	119	EWCH9001K
5.51	EWCH140	94,275	43	61.8	10,000	30.8	9.7	12.2	6.7	198	EWCH14001K
7.09	EWCH180	94,275	43	89.0	10,000	53.7	8.3	15.8	21.7	330	EWCH18001K

* Maximum material properties indicated refer to the material to be cut.



EWCE-Series Electric Wire and Cable Cutters

Their lighter weight allows for easier carrying and positioning. Available in 120V and 230V versions.

EWCE-Series Electric Wire and Cable Cutters combine the efficiency and safety of their hydraulic counterparts with the greater portability of electric tools.

EWCE Series



Maximum Material Hardness:

48 HRc

Maximum Material Diameter:

1.65 - 2.17 inches

Voltage*:

120 and 230 Volts

* ETL certification applies to 120V tools only

- ① Durable, guillotine-style blades maintain effectiveness throughout rigorous use
- ② Cutting head opens wide for easy positioning of wire or cable
- ③ Robust handles enable easy positioning and transport
- ④ Double-acting cylinder with directional control improves handling and reduces jamming



▼ Cut through wire and cables with ease.



Dimensions shown in inches.

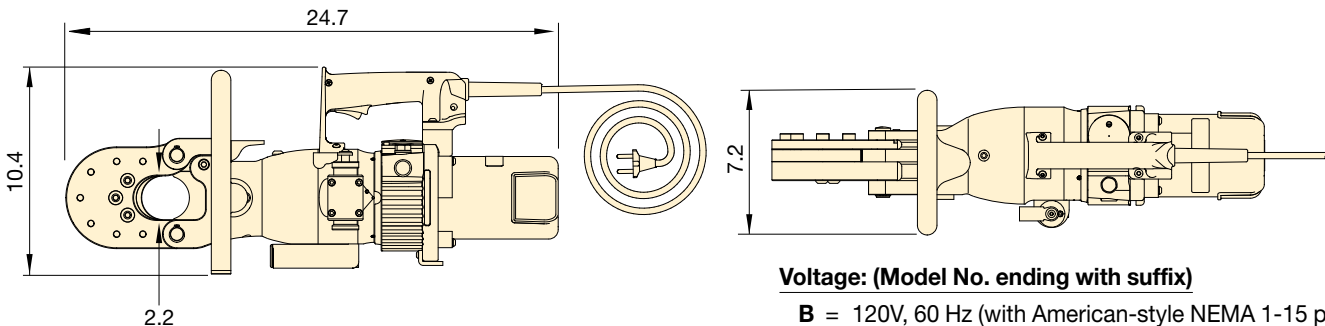

Voltage: (Model No. ending with suffix)

B = 120V, 60 Hz (with American-style NEMA 1-15 plug)

E = 230V, 50 Hz (with European-style SCHUKO plug)

Max. Material Diameter* (in)		Power Specifications				Model No.	Maximum Material Hardness* (HRc)	Maximum Cutting Force (tons)	Cord Length (ft)	Weight (lbs)	Replacement Blade Kit Number
Cable	Rope	Volts	Hz	Amps	Watts						
2.17	1.65	120	60	11.0	1300	EWCE55B	48	38.2	6	55	EWCE5501K
2.17	1.65	230	50	6.8	1400	EWCE55E	48	38.2	10	55	EWCE5501K

* Maximum material properties indicated refer to the material to be cut.

Cutter / Spreader Combination Tools

▼ Shown: **ECSE300B**



ECSE
Series



Maximum Material Hardness:

41 HRc

Maximum Blade Aperture:

11.81 inches

Voltage*:

120 and 230 Volts

* ETL certification applies to 120V tools only



Internal Mechanics

ECSE-Series: Cylinder is driven by a radial pump powered by an electric motor.



Typical Cutter / Spreader Applications

- Industrial manufacturing
- Recycling
- Demolition

Productivity

- Blades easily cut through metal profiles, pipes, rods and other obstructions
- Wedges on tips of blades provide powerful spreading force

Safety

- Controlled cutting process creates minimal spark risk compared with torching, grinding and sawing methods

Dimensions shown in inches.

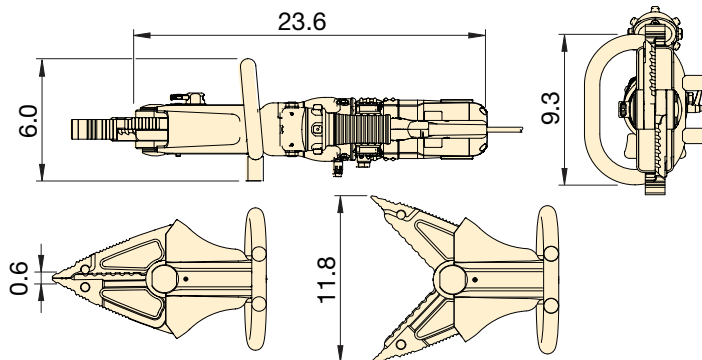

- ① Highly durable blades grip and cut through metal obstructions with ease
- ② Cutting head can be rotated 180 degrees in each direction for easier access to the application
- ③ Robust handle enables easy positioning and transport
- ④ Double-acting cylinder improves control and reduces jamming
- ⑤ Wedges provide powerful spreading force

Voltage: (Model No. ending with suffix)

B = 120V, 60 Hz (with American-style NEMA 1-15 plug)

E = 230V, 50 Hz (with European-style SCHUKO plug)

Maximum Blade Aperture (in)	Power Specifications				Model Number	Maximum Material Tensile Strength* (psi)	Maximum Material Hardness* (HRc)	Maximum Spreading Force** (tons)	Cord Length (ft)	Weight (lbs)	Replacement Jaws Kit Number
	Volts	Hz	Amps	Watts							
11.81	120	60	10.0	1200	ECSE300B	94,275	41	5.17	6	33	ECSE30001K
11.81	230	50	5.3	1100	ECSE300E	94,275	41	5.17	10	33	ECSE30001K

* Maximum material properties indicated refer to the material to be cut.

** 0.98 inches from jaw tips with jaws closed.

▼ Shown left to right: **WHC3380, WHC750**



WHC, WHR, STC Series

Capacity:
3 - 20 tons

Cutting Capacity:
0.50 - 4 inches

Maximum Operating Pressure:
10,000 psi

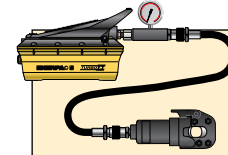

Cutterhead Sets

Hydraulic Cutterheads are available as sets (pump, tool and hose).

Cutter Model Number	Pump Model Number	Set Model Number †
WHC750	P392	STC750H
WHC750	P392FP	STC750FP
WHC750	PATG1102N	STC750A
WHC1250	P392	STC1250H
WHC1250	P392FP	STC1250FP
WHC1250	PATG1102N	STC1250A

†: H = Hand Pump, A = Air Operated Pump
FP = Foot Pump

- Single acting, spring-return on all models, except WHR1250
- Guillotine action for efficient operation
- Lifting handles on larger models
- Carrying bag included for easy carrying and tool protection
- Ideal for use with most Enerpac pumps featuring 3-way valve or dump valve and 10,000 psi pressure rating (except WHR1250, which requires 4-way valve)
- CR400 coupler and dust cap included on all models

▼ Steel rope is easily cut with the smooth guillotine action of an Enerpac cutterhead.



▼ Selection Chart Maximum Cutting Capacities (diameter in inches)

Cutter Head Operation	Model Number	Capacity (ton)	Oil Cap. (in ³)	Steel Wire Rope, Hemp-core or IWRC 6x7 6x12 6x19	Round Bar				Wire Strand				Cable		Length (in)	Wt. (lbs)	Replacement Blade Kit Numbers
					Copper Wire or Bar	Aluminum Wire or Bar	Soft Steel Bolts	Reinforcing Bar	Bare Copper Wire Strands	Bare Aluminum Wire Strands	ACSR	Guy Steel Wire Strands	Telephone Cable CPP	Underground Cable (Power)			
Single-acting	WHC750*	4	1.2	0.63	0.75	0.75	0.75	0.50***	0.75	0.75	0.75	0.63	☆	☆	5.00	7	WCB750
	WHC1250*	20	8.2	1.25	1.25	1.25	1.25	1.00	1.25	1.25	1.25	0.88	☆	☆	11.00	25	WCB1250
	WHC2000	13	7.3	1.00	1.25	1.25	0.88	☆	2.00	2.00	2.00	0.75	☆	☆	15.00	23	WCB2000
	WHC3380	3	4.0	☆	☆	☆	☆	☆	3.00	3.00	☆	☆	3.38	3.38	19.00	20	WCB3380
	WHC4000	8	8.4	☆	☆	☆	☆	☆	3.50	3.50	☆	☆	4.00	4.00	24.00	32	WCB4000
D/A**	WHR1250	20	7.5	1.25	1.25	1.25	1.25	1.00	1.25	1.25	1.25	0.88	☆	☆	16.50	26	WCB1250

* Available in sets. ** D/A = Double-acting *** Low Alloy

☆ Will not cut designated material

Self-Contained Hydraulic Cutters

▼ Shown left to right: **WMC2200, WMC750**



WMC Series

Capacity:

3 - 20 tons

Maximum Material Diameter:

0.38 - 3.38 inches



Replacement Blades

To order 60-62HRC hardened replacement blades use one of the model numbers shown below.

For Cutter Model Number	Order Blade Model Number
WMC580	WCB750
WMC750	WCB750
WMC1000	WCB1000
WMC1250	WCB1250
WMC2200	WCB2000
WMC 3380	WCB3380

- Rotating heads for operator convenience
- Guillotine action (except WMC1000) for efficient operation
- Carrying bag included for easy carrying and tool protection
- Velcro® straps to secure handles on larger models for easy transportation
- Spring-return on all models
- Lightweight, self-contained tool, can be used anywhere



Caution!

A "☆" in the charts on these pages means that this hydraulic cutter is not designed to cut this size or type of material. Any attempt to do so may result in personal injury and damage to the unit and will void the warranty.

▼ Selection Chart Maximum Cutting Capacities (diameter in inches)

Model Number	Capacity (ton)	Steel Wire Rope, Hemp-core or IWRC 6x7 6x12 6x19	Round Bar				Wire Strand					Cable		Length (in)	Weight (lbs)
			Copper Wire or Bar	Aluminum Wire or Bar	Soft Steel Bolts	Reinforcing Bar	Bare Copper Wire Strands	Bare Aluminum Wire Strands 6x7	ACSR Wire Strands	Guy Steel Wire Strands 1x7	Guy Steel Wire Strands 1x19	Telephone Cable CPP	Underground Cable (Power)		
WMC580	4	0.63	0.63	0.63	0.63	0.38	0.63	0.63	0.63	0.56	0.56	☆	☆	15.00	8
WMC750	4	0.75	0.75	0.75	0.69	0.50***	0.75	0.75	0.75	0.56	0.56	☆	☆	15.00	8
WMC1000*	20	☆	0.75	0.75	0.75	0.75	☆	☆	☆	☆	☆	☆	☆	26.75	25
WMC1250	20	1.25	1.25	1.25	1.25	0.88	1.25	1.25	1.25	0.88	0.88	☆	☆	26.75	23
WMC2200	13	1.00	1.25	1.25	0.88	☆	2.00	2.00	2.00	0.75	0.75	☆	☆	24.75	24
WMC3380	3	☆	☆	☆	☆	☆	3.00	3.00	☆	☆	☆	3.38	3.38	26.00	22

* Cuts .50" alloy chain grade 70 (type G7 transport or tie-down) or grade 80 (for overhead lifting applications)

☆ Will not cut designated material

*** Low Alloy



EBH-Series Bar Cutters and EWCH-Series Wire and Cable Cutters are powered by an external pump with an electric valve.

A twin hydraulic hose and electric cable connect the tools to the pump, allowing the user to operate them directly from a control panel located on the cutters.

ZE Series



Reservoir Capacity:

1.2 - 2.6 gallon

Motor Size:

1.5 - 7.5 hp

Maximum Operating Pressure:

10,000 psi

▼ Pumps used with EBH Bar Cutters and EWCH Wire & Cable Cutters



ZE4-Series Pump

Specialized **ZE4-Series** pumps provide a balance of speed and versatility, and are available in 115 and 230 volts. Recommended for use with **EBH30** and **EBH35** cutters when portability, or the convenience of using standard voltage is required.



ZE6-Series Pump

Specialized **ZE6-Series** three-phase pumps offer a high-flow rate that provides fast performance for demanding applications. Recommended for all **EWCH** and **EBH** bar cutting applications where speed is critical, or where higher flow rates are required by the application.



Gauges

Optional gauges and accessories may be used to monitor pressure in the hydraulic circuit. Enerpac recommends **Gauge Kit GKHC** for use with Enerpac hydraulic cutters.



Hoses

EBH- and EWCH-Series Cutters require a twin hose with an electric cable. The hose comes equipped with the appropriate couplers.

Required hoses sold separately.

Description	Model No.
20 ft. long, twin hose with sheath and electric cable	CH720EC

Voltage: (Model No. ending with suffix)

B = 115V, 50-60 Hz (with NEMA 5-15 plug)

E = 208-240V, 50-60 Hz (with commonly used European (SCHUKO) plug)

I = 208-240V, 50-60 Hz (with NEMA 6-15 plug)

Pump Series	Pump Model Number ^{1) 2)}	Motor Electrical Specification	Motor Size (hp)	Reservoir Capacity (gal)	Height (in)	Length (in)	Width (in)	Wt. (lbs)	Recommended Cutter Model Number (sold separately)
ZE4	ZE4404XB	115 V-1 ph 50-60 Hz	1.5	1.2	20.2	20.5	11.0	100	EBH30 EBH35
	ZE4404XE	208-240V-1 ph 50-60 Hz							
	ZE4404XI	208-240V-1 ph 50-60 Hz							
ZE6	ZE6410XG-S	208-240 V-3 ph	7.5	2.6	15.1	22	15.1	170	All EWCH- and EBH-Series Cutters
	ZE6410XJ-S	460-480 V-3 ph							
	ZE6410XK-S	440 V-3 ph							
	ZE6410XW-S	380-415 V-3 ph							

¹⁾ Indicated pumps come equipped with appropriate configurations to work with indicated cutters.

²⁾ ZE6 pumps are available with roll cages. To add a roll cage, add an "R" prior to the "S" in the nomenclature, e.g. ZE6410XG-RS.

Pumps and Accessories for EDCH Cutters



EDCH-Series Decommissioning Cutters are designed to work in a wide variety of environments, from factories to demolition projects.

Enerpac offers multiple pump options to provide power, speed and mobility for all your applications.

**ZE,
ZC
Series**



Reservoir Capacity:

1.2 - 2.6 gallon

Motor Size:

1.4 - 1.5 - 7.5 hp

Maximum Operating Pressure:

10,000 psi

▼ Pumps used with EDCH Decommissioning Cutters



ZC3-Series Pumps

Specialized ZC3-Series Cordless Pumps offer the portability of a cordless tool without the added weight of an integrated motor, combining freedom of movement with ease of use. Recommended for use with **EDCH130** cutters.



ZE4-Series Pumps

Specialized ZE4-Series Pumps provide a balance of speed and versatility. Recommended for use with all **EDCH** Cutters when the convenience of using standard voltage is required.



ZE6-Series Pump

Specialized ZE6-Series pumps offer a high-flow rate that provides fast performance. Recommended for use with all **EDCH** Cutters when 3-phase power is available, and speed is critical.



Gauges

Optional gauges and accessories may be used to monitor pressure in the hydraulic circuit. Enerpac recommends **Gauge Kit GKHC** for use with Enerpac hydraulic cutters.



Hoses

EDCH-Series Cutters require a twin hose for operation. The hose comes equipped with the appropriate couplers.

Required hoses sold separately.

Description	Model No.
20 ft. long, twin hose only	CH720MC

Voltage: (Model No. ending with suffix)

B = 115V, 50-60 Hz (with NEMA 5-15 plug)

E = 208-240V, 50-60 Hz (with commonly used European (SCHUKO) plug)

I = 208-240V, 50-60 Hz (with NEMA 6-15 plug)

Pump Series	Pump Model Number ^{1) 2)}	Motor Electrical Specification	Motor Size (hp)	Reservoir Capacity (gal)	Height (in)	Length (in)	Width (in)	Wt. (lbs)	Recommended Cutter Model Number (sold separately)
ZC3	ZC3204XB	Cordless (115 V Charger)	1.4	1.2	25.7	18.6	14.3	60	EDCH130
	ZC3204XE	Cordless (230 V Charger)							
ZE4	ZE4204XB	115 V-1 ph 50-60 Hz	1.5	1.2	20.2	20.5	11.0	100	EDCH130 EDCH145 EDCH170
	ZE4204XE	208-240V-1 ph 50-60 Hz							
	ZE4204XI	208-240V-1 ph 50-60 Hz							
ZE6	ZE6210XG-S	208-240 V-3 ph	7.5	2.6	15.1	22	15.1	170	
	ZE6210XJ-S	460-480 V-3 ph							
	ZE6210XK-S	440 V-3 ph							
	ZE6210XW-S	380-415 V-3 ph							

¹⁾ Indicated pumps come equipped with appropriate configurations to work with indicated cutters.

²⁾ ZE6 pumps are available with roll cages. To add a roll cage, add an "R" prior to the "S" in the nomenclature, e.g. ZE6210XG-RS.

Enerpac's Bolting Solutions caters to the complete bolting work-flow, ensuring joint integrity in a variety of applications throughout industry:

Joint Assembly

From simple pipe alignment to complex joint positioning of large structural assemblies, our comprehensive line of joint assembly products range from hydraulic and mechanical flange alignment and flange closing tools to PLC-controlled multi-point synchronous positioning systems.

Controlled Tightening

Enerpac offers a variety of controlled tightening options to best meet the requirements of your application. From manual torque multipliers to hydraulic and pneumatic driven square drive wrenches, and from low-profile hexagon torque wrenches to inter-connectable bolt tensioning tools; we offer the products you need for accurate and simultaneous tightening of multiple bolts.

Joint Separation

Enerpac also provides hydraulic nut splitters and a variety of mechanical and hydraulic spreading tools for joint separation during inspection, maintenance and decommissioning operations. High-quality bolting solutions from the brand you can trust. See how Enerpac can make your bolting work-flow more accurate, safer and efficient.



Enerpac Bolting Integrity Software Solutions

Enerpac Bolting Integrity Software Solutions play a key role in implementing and managing an Integrity Program for bolted connections.

The software is used by a wide range of clients worldwide often interfacing with maintenance, construction and commissioning management systems.























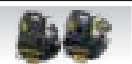
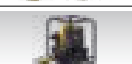

The software offers Tool selection, Bolt Load calculations and Tool pressure settings, as well as, a combined Application Data Sheet and Joint Completion Report.

Custom Joint information can also be entered.

Page: 416

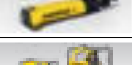
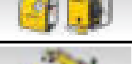

Bolting Tools and Pumps Section Overview

	Capacity	Tool Type and Functions	Series		Page
Controlled Tightening and Loosening	1400-26,150 Ft.lbs	Square Drive Hydraulic Torque Wrenches Rigid steel design & maximum versatility	S		240 ▶
	3/4 - 6 1/8 inches 19 - 155 mm	Heavy-duty Impact Sockets Square Drive	BSH		244 ▶
	1 1/16 - 4 15/16 inches 27- 120 mm	Back-Up Spanners for Torque Wrenches	BUS		245 ▶
	1 19/16 - 3 1/8 inches 46 - 75 mm	Safe T™ Torque Lock Hands-free torque wrench system	STTL		246 ▶
	2000-35,000 Ft.lbs 1980-4360 Ft.lbs	Low-Profile Hydraulic Torque Wrenches-Steel UltraSlim Stepped-Width Cassette	W W-SL		248 ▶ 258 ▶
	1408-28,002 Ft.lbs	Hexagon and Square Drive Torque Wrenches One drive, two tools	RSL, RLP RSL, RSQ		262 ▶
	1411-24,057 Ft.lbs	Square Drive Aluminum Torque Wrenches Setting Industry-First Safety Standards	DSX		274 ▶
	1541-13,489 Ft.lbs	Drive Units, Hexagon Cassettes and Square Drive Torque Wrenches	HMT, HLP, HSQ		278 ▶ 283 ▶
	750-8000 Ft.lbs	Manual Torque Multipliers	E		284 ▶
	1000-6000 Ft.lbs	Pneumatic Torque Wrenches	PTW		286 ▶
	148-7375 Ft.lbs	Mobile Calibration System For continuous rotation tools and hydraulic wrenches	MCS		290 ▶
		Selection Matrix Optimum Combinations Torque Wrenches - Torque Pumps - Hoses			291 ▶
	Flow 15 in ³ /min.	Portable Electric Torque Pumps Cordless Hydraulic Power	XC		292 ▶
	Flow 32 in ³ /min.	Electric Torque Pumps	E-Pulse		294 ▶
	Flow 60-120 in ³ /min.	Electric Torque Pumps	TQ		296 ▶
	Flow 60-120 in ³ /min.	Electric Torque Pumps	ZU4T		298 ▶
	Flow 60-120 in ³ /min.	Electric Torque Pumps	ZE4T, ZE5T		302 ▶
	Flow 25-60 in ³ /min.	Air Torque Pumps	LAT ZA4T		304 ▶ 306 ▶
	15.1 - 522.7 tons 25.2 - 444.9 tons	Topside Tensioners	HM GT		310 ▶ 314 ▶
	17.8 - 260.9 tons	Subsea Tensioners	EAJ		316 ▶
22.9 - 333.9 tons	Power Gen Tensioners Foundation Bolt Tensioners	PGT, FTR, FTE		318- 323 ▶	
0.037 in ³ /stroke	High-Pressure Hand Pump Ultra-High-Pressure Hoses & Couplers	HPT, HT, B		324 325	
Flow 4 in ³ /min. Flow 8-20 in ³ /min.	Ultra High-Pressure Air Pump Electric Tensioning Pumps	ATP ZUTP		327 ▶ 328	
Joint Assembly / Joint Separation	1-10 tons	Flange Alignment Tools	ATM		330 ▶
	8-14 tons	Step-type Industrial Spreaders	FSC, FSH, FSM		332 ▶
	1/2 - 2 7/8 A/F 2 3/4 - 5 3/8 A/F	Hydraulic Nut Splitters	NC, NSC NSH		334 ▶ 338
	1-12 in. flange	Mechanical Flange Face Tool	FF		340 ▶

▼ Shown: S3000PX



Setting New Standards in Safety, Simplicity and Performance



Two Handle Styles

Robust angled positioning handles come standard with every S-Series (X-Edition) tool. Straight positioning handles are available as accessories.

Compatible S-Series (X-Edition) wrenches	Angled positioning handles (standard)	Straight positioning handles (optional)
S1500X, S3000X	SWH6A	SWH6S
S6000X, S11000X	SWH10A	SWH10S
S25000X	Supplied with an eyebolt handle (SWH10EA)	

Safety and Performance

- Compact, high-strength uni-body construction provides a small operating radius without sacrificing endurance
- 35° rotation angle and rapid return stroke for fast operation
- Tough manifold design with added safety feature for enhanced operator safety

Simplicity

- 360° click-on reaction arm with quick release lever provides easier handling, even when wearing gloves
- Includes robust handle which mounts on both sides of tool for extra maneuverability
- Push button square drive release for quickly reversing the square drive for tightening or loosening

Versatility

- Available with optional enhanced tilt and swivel TSP300 manifold for horizontal and vertical maneuverability, with greater durability*

Accuracy

- Constant torque output provides accuracy of +/-3% across full stroke
- Optional Angle-of-Turn Indicator provides measurement of rotation

* TSP300 is designed for X-Edition tools only, and is not compatible with standard edition tools. For replacement components for existing tools, refer to repair sheet on www.enerpac.com



TSP - Pro Series Swivel

The optional TSP300 tilt and swivel manifold with robust interlocking design provides 360° X-axis rotation and 160° Y-axis rotation.

Page: 243

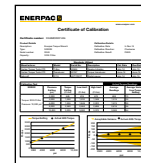

Calibration Certificate

All X-Edition tools are CE-ATEX certified and are shipped complete with a calibration certificate.

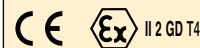

Bolting Integrity Software

Enerpac Bolting Integrity Software Solutions play a key role in implementing and managing an Integrity Program for bolted connections. The software offers Tool selection, Bolt Load calculations and Tool pressure settings, as well as, a combined Application Data Sheet and Joint Completion Report. Custom Joint information can also be entered.

Page: 416

Square Drive Hydraulic Torque Wrenches

Standard are ① ② ⑥ ⑧. Other items are optional.

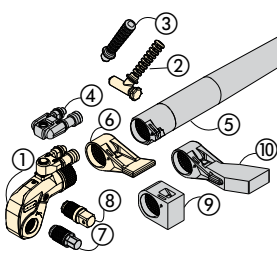

- ① Drive Unit
- ② Angled Positioning Handle
- ③ Straight Positioning Handle
- ④ Pro Series Swivel
- ⑤ Reaction Tube Extension
- ⑥ Standard Reaction Arm
- ⑦ Allen® Drive
- ⑧ Square Drive
- ⑨ Short Reaction Arm
- ⑩ Extended Reaction Arm



Select the Right Torque

Choose your Enerpac Torque Wrench using the untightening rule of thumb: Loosening torque equals about 250% of tightening torque.

S Series (X-Edition)



Nominal Torque at 10,000 psi:

26,150 Ft.lbs

Square Drive Range:

3/4 - 2 1/2 inches

Nose Radius:

0.98 - 2.52 inches

Maximum Operating Pressure:

10,000 psi

*TORQUE WRENCH SELECTION (based on hexagon socket size range)

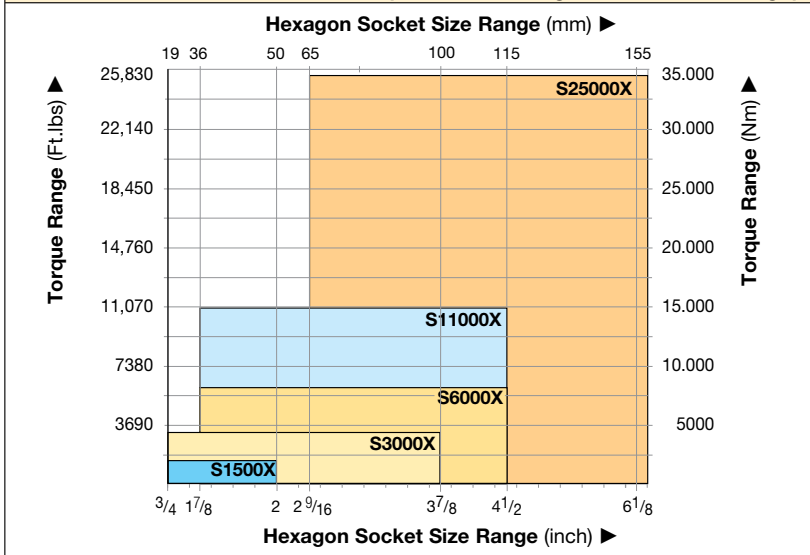

Use only Heavy-Duty Impact Sockets

For power-driven torquing equipment, according to ISO2725 and ISO1174; DIN 3129 and DIN 3121 or ASME-B107.2/1995.

Page: 244

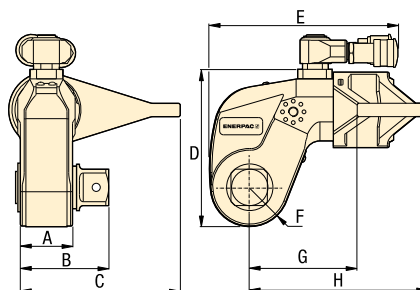

Back-Up Spanners

Hands free tool to be used to stop back nut from turning during make up or break out.

Page: 245



Safe T™ Torque Lock

The Safe T™ Torque Lock is suitable for all bolted applications from 140 to 11,070 ft-lbs. using a heavy-duty impact socket.

The patented mechanical locking system creates a hands-free torque wrench solution suitable for Enerpac only square drive tools.

Suitable for S3000X, S6000X, and S11000X.

Page: 246

Nominal Torque at 10,000 psi / 690 bar		Minimum Torque at 1000 psi / 69 bar		Square Drive		Angle-of-Turn Model No. (optional)	Torque Wrench Model No.*	Dimensions (in)								Wt. (lbs)
(Ft.lbs)	(Nm)	(Ft.lbs)	(Nm)	Size (in)	Model No. (included with wrench)			A	B	C	D	E	F	G	H	
1440	1952	144	195	3/4"	SD15-012	AOT15	S1500X	1.54	2.56	4.25	3.82	5.35	0.98	2.76	5.08	7.0
3225	4373	323	438	1"	SD30-100	AOT30	S3000X	1.89	3.15	5.31	5.04	6.81	1.30	3.54	6.34	12.3
6150	8338	615	834	1 1/2"	SD60-108	AOT60	S6000X	2.17	3.62	6.65	6.18	7.56	1.57	4.33	7.40	20.2
11,175	15,151	1,118	1,515	1 1/2"	SD110-108	AOT110	S11000X	2.83	4.49	7.76	7.48	8.98	1.95	5.24	9.02	34.7
26,150	35,455	2,615	3,545	2 1/2"	SD250-208	AOT250	S25000X	3.50	5.63	9.69	9.61	11.30	2.52	7.17	11.61	70.8

* To order a S-series (X-Edition) wrench fitted with the TSP swivel, insert a "P" prior to the "X" in the tool designation. e.g., **S1500PX**.

Nominal Torque at 10,000 psi:

26,150 ft.lbs.

Hexagon Size Allen® Drive:

1/2 - 2 1/4 in. (14-85 mm)

For
S
Series
(X-Edition)



TORQUE WRENCH	OPTIONAL ALLEN® DRIVES, IMPERIAL				OPTIONAL ALLEN® DRIVES, METRIC				SHORT REACTION ARM FOR ALLEN® DRIVES		
	Model Number	Hexagon Size (in)	Maximum Torque (ft.lbs)	Model Number	Dim. B1 (in)	Hexagon Size (mm)	Maximum Torque (ft.lbs)	Model Number	Dim. B1 (in)	Model Number	Dimensions (in) C1 H1
 S1500X (1440 Ft-lbs)	1/2	355	SDA15008	2.6	14	475	SDA1514	2.60	 SRA15X	2.66	2.56
	5/8	690	SDA15010	2.6	17	850	SDA1517	2.68			
	3/4	1195	SDA15012	2.8	19	1185	SDA1519	2.76			
	7/8	1400	SDA15014	2.9	22	1400	SDA1522	2.87			
	1	1400	SDA15100	3.0	24	1400	SDA1524	2.91			
S3000X (3225 Ft-lbs)	5/8	690	SDA30010	3.0	17	850	SDA3017	3.03	SRA30X	3.15	2.91
	3/4	1195	SDA30012	3.1	19	1185	SDA3019	3.11			
	7/8	1895	SDA30014	3.3	22	1835	SDA3022	3.23			
	1	2825	SDA30100	3.4	24	2385	SDA3024	3.31			
	1 1/8	3200	SDA30102	3.5	27	3200	SDA3027	3.35			
	1 1/4	3200	SDA30104	3.5	30	3200	SDA3030	3.43			
	-	-	-	-	32	3200	SDA3032	3.46			
S6000X (6050 Ft-lbs)	5/8	690	SDA60010	3.3	17	850	SDA6017	3.39	SRA60X	3.60	3.50
	3/4	1195	SDA60012	3.5	19	1185	SDA6019	3.46			
	7/8	1895	SDA60014	3.6	22	1835	SDA6022	3.58			
	1	2825	SDA60100	3.7	24	2385	SDA6024	3.66			
	1 1/8	4025	SDA60102	3.8	27	3395	SDA6027	3.70			
	1 1/4	5520	SDA60104	3.9	30	4655	SDA6030	3.78			
	-	-	-	-	32	5650	SDA6032	3.82			
S11000X (11,175 Ft-lbs)	1 1/4	5520	SDA110104	4.5	30	4655	SDA11030	4.41	SRA110X	5.02	4.17
	1 3/8	7345	SDA110106	4.6	32	5650	SDA11032	4.49			
	1 1/2	9535	SDA110108	4.6	36	8040	SDA11036	4.61			
	1 5/8	11,000	SDA110110	4.8	41	11,000	SDA11041	4.76			
	1 3/4	11,000	SDA110112	4.9	46	11,000	SDA11046	5.00			
S25000X (26,150 Ft-lbs)	1 1/2	9535	SDA250108	5.5	36	8040	SDA25036	5.51	SRA250X	6.24	5.31
	1 5/8	12,120	SDA250110	5.7	41	11,880	SDA25041	5.67			
	1 3/4	15,135	SDA250112	5.8	46	16,775	SDA25046	5.83			
	1 7/8	18,620	SDA250114	5.9	50	21,545	SDA25050	5.94			
	2	22,595	SDA250200	5.9	55	26,150	SDA25055	6.06			
	2 1/4	26,150	SDA250204	6.0	60	26,150	SDA25060	6.22			
	-	-	-	-	65	26,150	SDA25065	6.34			
	-	-	-	-	70	26,150	SDA25070	6.46			
	-	-	-	-	75	26,150	SDA25075	6.61			
	-	-	-	-	85	26,150	SDA25085	6.89			

Accessories for S-Series, X-Edition Torque Wrenches

TSP-Series, Pro Series Swivels

- Robust interlocking design
- 360° X-axis and 160° Y-axis rotation
- Increases tool fit in restricted access areas
- Simplifies hose placement
- Includes male and female couplers

**TSP
RTEX
SRSX
Series**

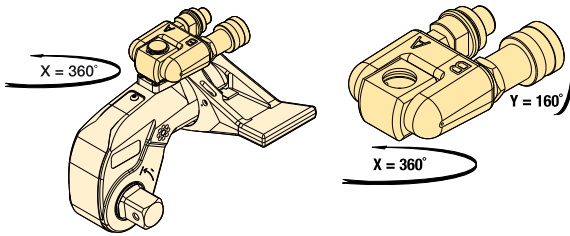

TSP Series

Torque Wrench Model Number	Model Number	Maximum Pressure (psi)	Wt. (lbs)
S1500X, S3000X, S6000X, S11000X, S25000X	TSP300*	10,000	0.44

Note: To order a S-series (X-Edition) wrench fitted with the TSP swivel, insert a "P" prior to the "X" in the tool designation, e.g., **S1500PX**.

* TSP300 is designed for X-Edition tools only, and is not compatible with standard edition tools. For replacement components for existing tools, refer to repair sheet on www.enerpac.com

RTEX-Series, Reaction Tube Extensions

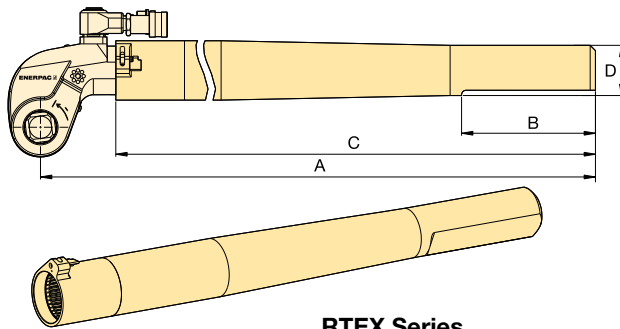

RTEX Series

- Full torque rated
- Increases tool fit in restricted access areas

Torque Wrench Model Number	Model Number	Dimensions (in)				Wt. (lbs)*
		A	B	C	D	
S1500X	RTE15X	27.80	5.98	25.04	2.28	10.1
S3000X	RTE30X	28.86	5.98	25.47	2.24	12.1
S6000X	RTE60X	29.41	5.98	25.94	2.56	17.0
S11000X	RTE110X	30.28	5.98	26.57	2.99	24.7
S25000X	RTE250X	32.01	5.98	26.97	3.94	38.1

* Weights indicated are for the accessories only and do not include the wrench.

SRSX-Series, Extended Reaction Arms

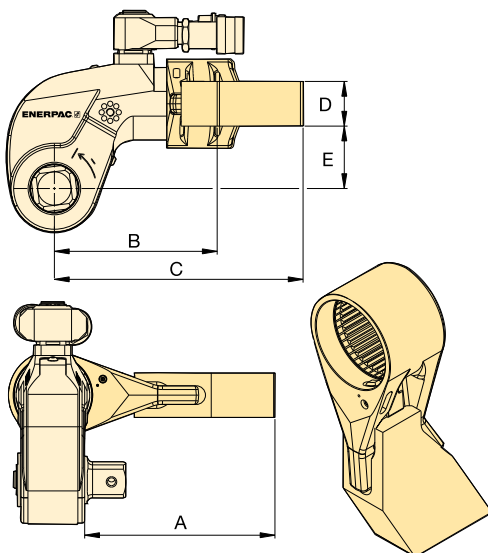

SRSX Series

- Lightweight interchangeable design

Wrench Model	Max. Torque (Ft-lbs)	Model Number	Dimensions (in)					Wt. (lbs)*
			A	B	C	D	E	
S1500X	1328	SRS151X	3.70	3.39	5.00	0.94	1.34	1.8
	1210	SRS152X	4.69	3.82	5.43	0.94	1.34	2.2
	1131	SRS153X	5.71	4.29	5.83	0.94	1.34	2.6
S3000X	2890	SRS301X	4.37	4.17	6.61	1.34	1.89	3.5
	2739	SRS302X	5.39	4.61	7.17	1.34	1.89	4.4
	2638	SRS303X	6.38	5.20	7.80	1.34	1.89	5.5
S6000X	5784	SRS601X	5.43	5.04	7.56	1.54	2.44	5.1
	5501	SRS602X	6.42	5.67	8.15	1.54	2.44	6.0
	5295	SRS603X	7.44	6.26	8.74	1.54	2.44	7.5
S11000X	10,812	SRS1101X	5.87	6.18	9.13	1.81	2.99	9.7
	10,300	SRS1102X	6.89	6.77	9.72	1.81	2.99	11.2
	9883	SRS1103X	7.87	7.36	10.28	1.81	2.99	12.8
S25000X	24,751	SRS2501X	7.20	8.23	11.61	1.97	3.94	16.8
	23,652	SRS2502X	8.19	8.74	12.20	1.97	3.94	18.5
	22,694	SRS2503X	9.17	9.29	12.83	1.97	3.94	22.0

* Weights indicated are for the accessories only and do not include the wrench.

- Heavy-duty impact sockets
- Supplied with "Pin and Ring"

METRIC SOCKETS							
3/4" Square Drive		1" Square Drive		1 1/2" Square Drive		2 1/2" Square Drive	
A/F (mm)	Model Number	A/F (mm)	Model Number	A/F (mm)	Model Number	A/F (mm)	Model Number
19	BSH7519	19	BSH1019	36	BSH1536	65	BSH2565
24	BSH7524	24	BSH1024	41	BSH15163	70	BSH2570
27	BSH7527	27	BSH1027	46	BSH1546	75	BSH2575
30	BSH7530	30	BSH1030	50	BSH1550	80	BSH2580
32	BSH7532	32	BSH1032	55	BSH1555	85	BSH2585
36	BSH7536	36	BSH1036	60	BSH1560	90	BSH2590
41	BSH75163	41	BSH10163	65	BSH1565	95	BSH2595
46	BSH7546	46	BSH1046	70	BSH1570	100	BSH25100
50	BSH7550	50	BSH1050	75	BSH1575	105	BSH25105
-	-	55	BSH1055	80	BSH1580	110	BSH25110
-	-	60	BSH1060	85	BSH1585	115	BSH25115
-	-	65	BSH1065	90	BSH1590	120	BSH25120
-	-	70	BSH1070	95	BSH1595	125	BSH25125
-	-	75	BSH1075	100	BSH15100	135	BSH25135
-	-	80	BSH1080	105	BSH15105	140	BSH25140
-	-	85	BSH1085	110	BSH15110	145	BSH25145
-	-	90	BSH1090	115	BSH15115	150	BSH25150
-	-	95	BSH1095	-	-	155	BSH25155
-	-	100	BSH10100	-	-	-	-

BSH Series



Hexagon Sizes:

3/4 - 6 1/8 inches | 19 - 155 mm



Select the Right Torque

Choose your Enerpac Torque Wrench using the untightening rule of thumb: Loosening torque equals about 250% of tightening torque.

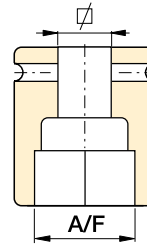

Pin and Ring

All sockets are supplied with a "Pin and Ring" to hold the socket in place on the square drive of the tool.

IMPERIAL SOCKETS													
3/4" Square Drive		1" Square Drive				1 1/2" Square Drive				2 1/2" Square Drive			
A/F (in)	Model Number	A/F (in)	Model Number	A/F (in)	Model Number	A/F (in)	Model Number	A/F (in)	Model Number	A/F (in)	Model Number	A/F (in)	Model Number
3/4"	BSH7519	3/4"	BSH1019	2 5/16"	BSH10231	1 7/16"	BSH15144	2 13/16"	BSH15281	2 7/16"	BSH25244	4 3/16"	BSH25419
7/8"	BSH75088	7/8"	BSH10088	2 3/8"	BSH10238	1 1/2"	BSH1538	2 7/8"	BSH15288	2 1/2"	BSH25250	4 1/4"	BSH25425
15/16"	BSH75094	15/16"	BSH10094	2 7/16"	BSH10244	1 9/16"	BSH15156	2 15/16"	BSH1575	2 9/16"	BSH2565	4 5/16"	BSH25110
1 1/16"	BSH7527	1 1/16"	BSH1027	2 1/2"	BSH10250	1 5/8"	BSH15163	3"	BSH15300	2 5/8"	BSH25263	4 3/8"	BSH25438
1 3/16"	BSH7530	1 3/16"	BSH1030	2 9/16"	BSH1065	1 11/16"	BSH1543	3 1/16"	BSH15306	2 11/16"	BSH25269	4 1/2"	BSH25450
1 1/4"	BSH75125	1 1/4"	BSH10125	2 5/8"	BSH10263	1 3/4"	BSH15175	3 1/8"	BSH15313	2 3/4"	BSH2570	4 5/8"	BSH25463
1 5/16"	BSH75131	1 5/16"	BSH10131	2 11/16"	BSH10269	1 13/16"	BSH1546	3 3/16"	BSH15319	2 13/16"	BSH25281	4 3/4"	BSH25475
1 3/8"	BSH7535	1 3/8"	BSH1035	2 3/4"	BSH1070	1 7/8"	BSH15188	3 1/4"	BSH15325	2 7/8"	BSH25288	4 7/8"	BSH25488
1 7/16"	BSH75144	1 7/16"	BSH10144	2 13/16"	BSH10281	1 15/16"	BSH15194	3 3/8"	BSH15338	2 15/16"	BSH2575	5"	BSH25500
1 1/2"	BSH7538	1 1/2"	BSH1038	2 7/8"	BSH10288	2"	BSH15200	3 1/2"	BSH15350	3"	BSH25300	5 1/8"	BSH25513
1 9/16"	BSH75156	1 9/16"	BSH10156	2 15/16"	BSH1075	2 1/16"	BSH15206	3 5/8"	BSH15363	3 1/16"	BSH25306	5 3/16"	BSH25519
1 5/8"	BSH75163	1 5/8"	BSH10163	3"	BSH10300	2 1/8"	BSH15213	3 3/4"	BSH1595	3 1/8"	BSH25313	5 1/4"	BSH25525
1 11/16"	BSH7543	1 11/16"	BSH1043	3 1/16"	BSH10306	2 3/16"	BSH15219	3 7/8"	BSH15388	3 3/16"	BSH25319	5 3/8"	BSH25538
1 3/4"	BSH75175	1 3/4"	BSH10175	3 1/8"	BSH10313	2 1/4"	BSH15225	3 15/16"	BSH15100	3 1/4"	BSH25325	5 1/2"	BSH25140
1 13/16"	BSH7546	1 13/16"	BSH1046	3 3/16"	BSH10319	2 5/16"	BSH15231	4"	BSH15400	3 3/8"	BSH25338	5 3/4"	BSH25575
1 7/8"	BSH75188	1 7/8"	BSH10188	3 1/4"	BSH10325	2 3/8"	BSH15238	4 1/8"	BSH15105	3 1/2"	BSH25350	5 7/8"	BSH25150
1 15/16"	BSH75194	1 15/16"	BSH10194	3 3/8"	BSH10338	2 7/16"	BSH15244	4 3/16"	BSH15419	3 5/8"	BSH25363	6"	BSH25600
2"	BSH75200	2"	BSH10200	3 1/2"	BSH10350	2 1/2"	BSH15250	4 1/4"	BSH15425	3 3/4"	BSH2595	6 1/8"	BSH25613
-	-	2 1/16"	BSH10206	3 5/8"	BSH10363	2 9/16"	BSH1565	4 5/16"	BSH15110	3 7/8"	BSH25388	-	-
-	-	2 1/8"	BSH10213	3 3/4"	BSH1095	2 5/8"	BSH15263	4 3/8"	BSH15438	3 15/16"	BSH25100	-	-
-	-	2 3/16"	BSH10219	3 7/8"	BSH10388	2 11/16"	BSH15269	4 1/2"	BSH15450	4"	BSH25400	-	-
-	-	2 1/4"	BSH10225	-	-	2 3/4"	BSH1570	4 5/8"	BSH15463	4 1/8"	BSH25105	-	-

Back-Up Spanners for Torque Wrenches

▼ **BUS03 Back-Up Spanner** (safety cable not shown)



- Hands free solution – improves operator safety
- Eliminates the need for flogging spanners
- Speeds up the bolting process
- Includes safety cable with quick-connect carabiners, stainless steel tethers and secure Allen-key fixings
- Won't lock on during operations
- Lightweight, spark-free and non-impact for improved safety and ease of use
- Two hexagon sizes in one tool

▼ **SELECTION CHART BACK-UP SPANNERS**

Hexagon Sizes (A/F)		Model Number	Dimensions (in)				Wt. (lbs)
S1 to S2 (in)	S1 to S2 (mm)		A	B	C	D	
1 1/16 - 1 1/4"	27 - 32	BUS01	2.0	3.9	0.6	M8	0.7
1 7/16 - 1 5/8"	36 - 41	BUS02	2.4	4.7	0.6	M8	0.9
1 13/16 - 2"	46 - 50	BUS03	3.0	5.6	0.8	M8	1.3
2 3/16 - 2 3/8"	55 - 60	BUS04	3.5	6.5	0.8	M12	1.8
2 9/16 - 2 3/4"	65 - 70	BUS05	3.9	7.5	1.0	M16	2.2
2 15/16 - 3 1/8"	75 - 80	BUS06	4.4	8.4	1.0	M16	2.9
3 1/2 - 3 7/8"	-	BUS07	5.3	10.1	1.2	M20	4.9
4 1/4 - 4 5/8"	-	BUS08	6.4	12.2	1.2	M20	7.3
-	85 - 90	BUS09	5.0	9.5	1.0	M16	3.7
3 3/4 - 3 15/16"	95 - 100	BUS10	5.4	10.5	1.2	M20	5.1
4 1/8 - 4 15/16"	105 - 110	BUS11	6.0	11.7	1.2	M20	6.8
-	115 - 120	BUS12	6.5	12.6	1.2	M20	7.7

BUS Series

Hexagon Sizes (A/F):

1 1/16 - 4 15/16 inches

Hexagon Sizes (A/F):

27 - 120 mm



Back-Up Spanners

Hands free operation of a hydraulic torque wrench improves the safety of the operator significantly.

Enerpac Back-Up Spanners are a hands-free tool that eliminates the need to use a flogging spanner as a backing tool.

The Back-Up Spanners have been specifically designed to prevent them from locking onto the nut during bolt torquing operations. They fit easily onto the back nut and prevent it from turning during make up or break out of bolted joints.

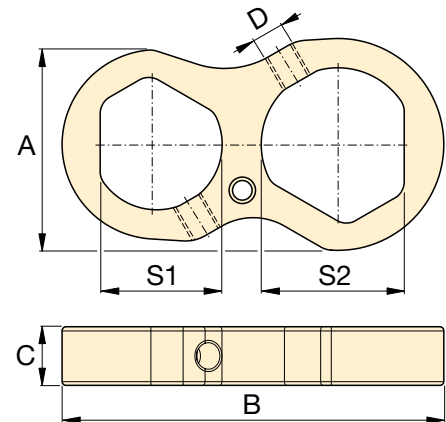

▼ *Enerpac Back-Up Spanners to be used to stop back nut from turning during make up or break out.*



▼ Shown: STTLS Safe T™ Torque Lock



Hands-free Torque Wrench System



Safe T™ Torque Lock

The Safe T™ Torque Lock is suitable for all bolted applications from 140 ft-lbs to 11,175 ft-lbs. using a heavy-duty impact socket.

The patented mechanical locking system creates a hands-free torque wrench solution suitable for Enerpac only square drive tools.

Suitable for:

S-Series	RSQ-Series
S3000X	RSQ3000
S6000X	RSQ5000
S11000X	RSQ11000



IMPORTANT:

Safe T™ Torque Lock not suitable for use on PTFE coated nuts.

▼ *Hands-free torque wrench system: STTLS-model with S-Series torque wrench. The square drive of the wrench can easily be exchanged by the Safe T™ Torque Lock model.*



Safety – Safe T™ Torque Lock

- Transforming Enerpac S-Series and RSQ-Series wrenches into a dedicated hands-free tool
- Improves operator safety during bolting operations by minimizing exposure to pinch points and high-pressure hydraulic connections
- Grips securely to the application in any orientation, including inverted positions
- Minimizes drop hazards of falling tools
- Reduces operator fatigue on overreaching or awkward positioning of the tool

Simplicity

- With one twist of the locking collar the Safe T™ Torque Lock grips onto the application, firmly holding the full tool weight in place
- Assembles onto the torque wrench with one push of the square drive quick-release button for tightening or loosening
- Locking feature dramatically reduces the number of tool lifts

Versatility

- Suitable for both S-Series & RSL-Series squaredrive wrenches
- Simple twist & lock mechanism is user friendly, easy to operate
- No additional loose components like reaction washers are needed



Common Torque Lock Applications:

- Oil & Gas flanges
- Tower Crane installation
- Machine installation/assembly (Mining),
- Wind Tower installation etc.

Industries

- Oil & Gas, Petrochemical
- Wind Power Generation
- Mining
- Marine
- Manufacturing
- Rail and more

STTL Series



Hexagon Range (A/F):

1¹³/₁₆ - 3¹/₈ inch

Hexagon Range (A/F)

46 - 75 mm

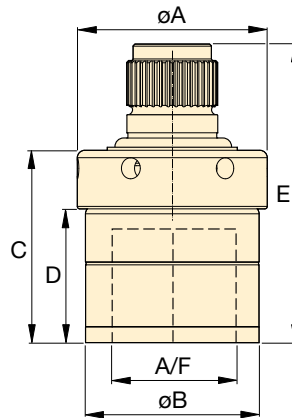
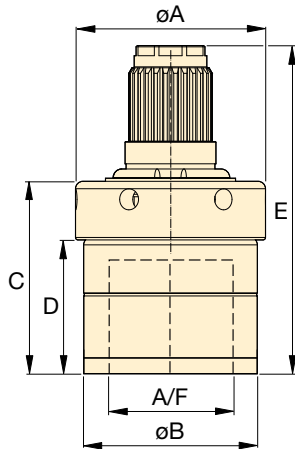

STTLS
for S-Series Spline Fitting

STTLR
for RSQ-Series Spline Fitting



Back-Up Spanners

Hands free tool to be used to stop back nut from turning during make up or break out.

Hexagon Sizes (A/F)		For use with torque wrench model	Safe T™ Torque Lock Model Number		Dimensions (in)					Wt. (lbs)	Dimensions (mm)					Wt. (kg)
(inch)	(mm)		For S-Series Spline Fitting	For RSQ-Series Spline Fitting	A	B	C	D	E		A	B	C	D	E	
1 ¹³ / ₁₆	46	S3000X	STTLS31046	-	3.0	2.8	3.1	2.1	5.2	4.4	77	71	78	54	133	2.0
		RSQ3000	-	STTLR31046					4.8	4.2					121	1.9
2	50	S3000X	STTLS31550	-	3.5	3.2	3.1	2.1	5.2	5.7	89	82	78	54	133	2.6
		RSQ3000	-	STTLR31550					4.8	5.7					123	2.6
2 ³ / ₁₆	55	S3000X	STTLS31055	-	3.7	3.4	3.3	2.3	5.4	6.6	93	86	83	58	138	3.0
		RSQ3000	-	STTLR31055					5.1	6.4					130	2.9
2 ³ / ₈	-	RSQ3000	-	STTLR315238	3.9	3.6	3.6	2.6	5.4	7.7	99	92	91	67	136	3.5
2	50	RSQ5000	-	STTLR51550	3.5	3.2	3.1	2.1	5.2	5.9	89	82	78	54	132	2.7
		S6000X	STTLS61560M	-					5.9	8.2					150	3.7
-	60	RSQ5000	-	STTLR51560M	3.9	3.6	3.4	2.5	5.7	8.2	99	92	86	62	145	3.7
		S6000X	STTLS615238	-					6.0	8.4					154	3.8
2 ³ / ₈	-	RSQ5000	-	STTLR515238	3.9	3.6	3.6	2.6	5.9	8.4	99	92	91	67	150	3.8
		S6000X	STTLS61565	-					6.8	11.7					172	5.3
2 ⁹ / ₁₆	65	RSQ5000	-	STTLR51565	4.2	3.9	4.2	2.9	6.6	11.9	107	100	108	74	168	5.4
		S6000X	STTLS61570	-					6.8	13.0					173	5.9
2 ³ / ₄	70	RSQ5000	-	STTLR51570	4.5	4.2	4.3	3.0	6.7	13.2	114	107	109	76	169	6.0
		S6000X	STTLS61575	-					7.0	12.3					177	5.6
2 ¹⁵ / ₁₆	75	RSQ5000	-	STTLR51575	4.4	4.1	4.4	3.1	6.9	13.2	112	105	113	80	173	5.8
		S6000X	STTLS61575	-					7.7	13.2					195	6.0
-	60	RSQ11000	-	STTLR111560M	3.9	3.6	3.4	2.5	6.1	9.3	99	92	86	62	156	4.2
		S11000X	STTLS111560M	-					6.6	9.3					167	4.2
2 ⁹ / ₁₆	65	RSQ11000	-	STTLR111565	4.2	3.9	4.2	2.9	7.5	12.8	107	100	107	74	189	5.8
		S11000X	STTLS111565	-					7.0	12.8					178	5.8
2 ³ / ₄	70	RSQ11000	-	STTLR111570	4.5	4.2	4.3	3.0	7.5	14.1	114	107	109	76	191	6.4
		S11000X	STTLS111570	-					7.1	14.3					181	6.5
2 ¹⁵ / ₁₆	75	RSQ11000	-	STTLR111575	4.4	4.1	4.4	3.1	7.7	13.2	112	105	113	80	195	6.0
		S11000X	STTLS111575	-					7.2	13.2					183	6.0
3 ¹ / ₈	-	RSQ11000	-	STTLR1115318	4.8	4.5	4.5	3.2	7.8	16.1	122	115	115	81	197	7.3
		S11000X	STTLS1115318	-					7.3	16.3					185	7.4

▼ W4206X cassette with W4000PX drive unit



Setting New Standards in Safety, Simplicity and Performance



Two Handle Styles

Robust angled positioning handles come standard with every W-Series (X-Edition) tool. Straight positioning handles, designed for extreme limited access applications, are available as accessories.

Compatible W-Series (X-Edition) Wrenches	Angled Positioning Handles (standard)	Straight Positioning Handles (optional)
W2000X, W4000X	SWH6A	SWH6S
W8000X, W15000X	SWH10A	SWH10S
W22000X, W35000X	Supplied with an eyebolt handle (SWH10EA)	

Safety and Performance

- Superior strength to size ratio provides easy access to difficult to reach applications without sacrificing endurance
- 30° rotation angle and rapid return stroke provide fast operation
- Tough manifold design with added safety feature for enhanced operator safety

Simplicity

- Fast release drive unit enables rapid exchange of cassettes, no tools required and no pins to lose
- Drive unit includes robust handle which mounts on both sides to allow for extra maneuverability
- Quick and easy disassembly for maintenance without special tools

Versatility

- Available with optional enhanced tilt and swivel TSP300 manifold for horizontal and vertical maneuverability, with greater durability*
- X-Edition drive units, cassettes and most accessories are compatible with standard edition tools *
- Drive unit compatible with UltraSlim cassettes

Accuracy

- Constant torque output provides accuracy of +/-3% across full stroke

* TSP300 is designed for X-Edition tools only, and is not compatible with standard edition tools. For replacement components for existing tools, refer to repair sheet on www.enerpac.com



TSP - Pro Series Swivel

The optional TSP300 tilt and swivel manifold with robust interlocking design provides 360° X-axis rotation and 160° Y-axis rotation.

Page: 260

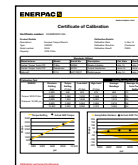

Calibration Certificate

All X-Edition cassettes are CE-ATEX certified, factory calibrated and are shipped complete with a calibration certificate.

CE Ex II 2 GD ck T4
CSA/SIRA 15XT072



Bolting Integrity Software

Enerpac Bolting Integrity Software Solutions play a key role in implementing and managing an Integrity Program for bolted connections. The software offers Tool selection, Bolt Load calculations and Tool pressure settings, as well as, a combined Application Data Sheet and Joint Completion Report. Custom Joint information can also be entered.

Page: 416

Double-Acting Hydraulic Hexagon Wrenches, X-Edition

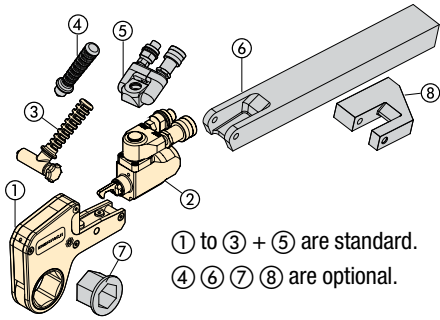

- ① Hexagon Cassette (pages 250-257)
- ② Drive Unit (page 249)
- ③ Angled Positioning Handle (page 248)
- ④ Straight Positioning Handle (page 248)
- ⑤ Pro Series Swivel (page 260)
- ⑥ Extended Reaction Arm (page 260)
- ⑦ Reducer Insert (pages 250-257)
- ⑧ Reaction Paddle (page 260)

① to ③ + ⑤ are standard.
④ ⑥ ⑦ ⑧ are optional.

W Series (X-Edition)



Nominal Torque at 10,000 psi:

35,000 ft.lbs

Hexagon Range:

1 1/16 - 6 1/8 in | 30-155 mm

Nose Radius:

1.22 - 4.52 inches

Maximum Operating Pressure:

10,000 psi

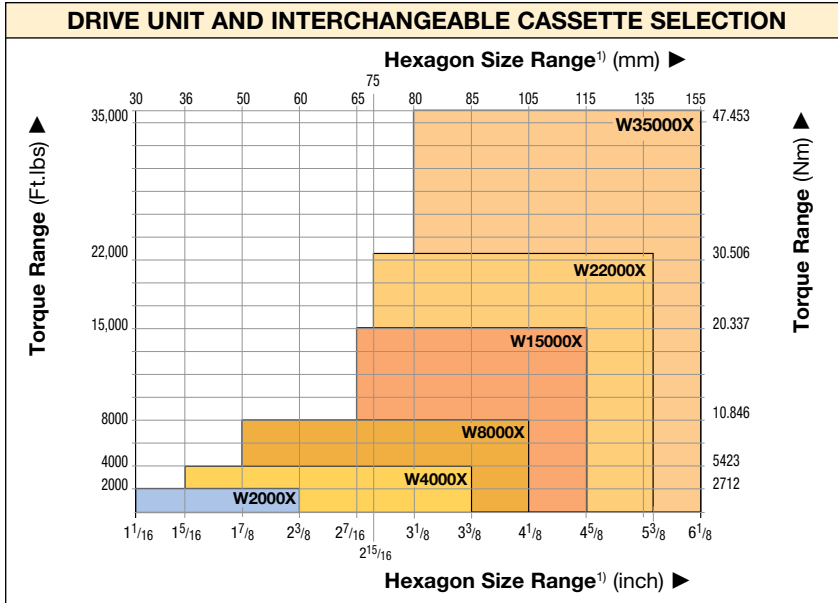

¹⁾ See page 411 for table of hexagon sizes of bolts, nuts and related thread diameters.

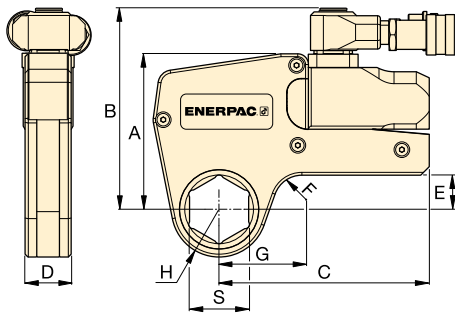

SELECTION CHART

Hexagon Range *	Nominal Torque at 10,000 psi		Drive Unit Model Number **	Minimum Torque		Dimensions (in)					Weight (lbs)	
	(in)	(mm)		(Ft.lbs)	(Nm)	(Ft.lbs)	(Nm)	A	B	C		D
1 1/16 - 2 3/8	30 - 60	2040	2766	W2000X	204	277	4.29	5.55	5.83	1.26	0.79	3.04
1 5/16 - 3 3/8	36 - 85	4175	5661	W4000X	418	566	5.35	6.57	7.01	1.61	0.79	4.44
1 7/8 - 4 1/8	50 - 105	8470	11,484	W8000X	847	1148	6.77	8.07	8.19	2.07	0.98	6.59
2 7/16 - 4 5/8	65 - 115	15,330	20,785	W15000X	1533	2079	8.15	9.45	9.96	2.48	0.79	10.72
2 15/16 - 5 3/8	75 - 135	22,500	30,506	W22000X	2250	3050	8.94	10.46	11.68	3.03	1.38	16.98
3 1/8 - 6 1/8	80-155	35,000	47,453	W35000X	3500	4745	10.54	11.94	13.60	3.57	1.98	26.40

* With in-line reaction foot.

** To order a W-series (X-Edition) wrench fitted with the TSP swivel, insert a "P" prior to the "X" in the tool designation. e.g., W2000PX.



Torque Wrench Pump Selection Matrix

For optimum speed and performance see the torque wrench and pump matrix.

Page: 291

▼ These rigid steel wrenches with low-profile interchangeable hexagon cassettes guarantee durability and maximum versatility in bolting applications.



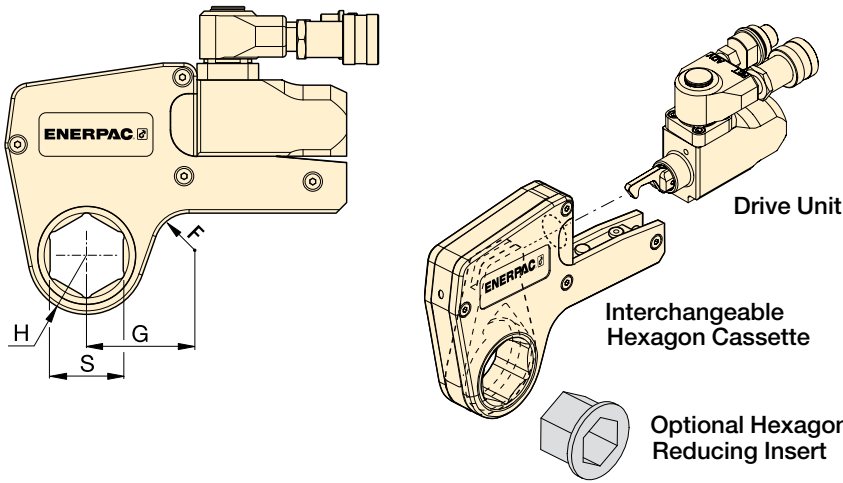

W Series (X-Edition)



Nominal Torque at 10,000 psi:

2040 ft.lbs

Hexagon Range:

1¹/₁₆ - 2³/₈ inches

Maximum Operating Pressure:

10,000 psi



Metric Sizes

For metric sizes of hexagon cassettes and reducer inserts see:

Page: 256



Back-Up Spanners

Hands free tool to be used to stop back nut from turning during make up or break out.

Page: 245

SELECTION CHART

Drive Unit Model Number	Hexagon Size	Nose Radius	Dim. G (in)	Model Number	Wt. (lbs)	Hexagon Reducer		Hexagon Reducer		Hexagon Reducer	
						Hexagon Reducer (in)	Model Number	Hexagon Reducer (in)	Model Number	Hexagon Reducer (in)	Model Number
W2000X	1 ¹ / ₁₆	1.22	2.11	W2101X	4.19	-	-	-	-	-	-
	1 ¹ / ₈	1.22	2.11	W2102X	4.19	-	-	-	-	-	-
	1 ³ / ₁₆	1.22	2.11	W2103X	4.19	-	-	-	-	-	-
	1 ¹ / ₄	1.22	2.11	W2104X	4.19	-	-	-	-	-	-
	1 ⁵ / ₁₆	1.22	2.11	W2105X	4.48	-	-	-	-	-	-
	1 ³ / ₈	1.22	2.11	W2106X	4.43	-	-	-	-	-	-
	1 ⁷ / ₁₆	1.22	2.11	W2107X	4.37	1 ⁷ / ₁₆ - 1 ¹ / ₈	W2107R102	-	-	-	-
	1 ¹ / ₂	1.32	2.29	W2108X	4.51	-	-	-	-	-	-
	1 ⁹ / ₁₆	1.32	2.29	W2109X	4.44	-	-	-	-	-	-
	1 ⁵ / ₈	1.32	2.29	W2110X	4.38	1 ⁵ / ₈ - 1 ¹ / ₄	W2110R104	1 ⁵ / ₈ - 1 ³ / ₁₆	W2110R103	-	-
	1 ¹¹ / ₁₆	1.44	2.38	W2111X	4.63	-	-	-	-	-	-
	1 ³ / ₄	1.44	2.38	W2112X	4.57	-	-	-	-	-	-
	1 ¹³ / ₁₆	1.44	2.38	W2113X	4.46	1 ¹³ / ₁₆ - 1 ⁷ / ₁₆	W2113R107	1 ¹³ / ₁₆ - 1 ¹ / ₄	W2113R104	-	-
	1 ⁷ / ₈	1.54	2.48	W2114X	4.69	-	-	-	-	-	-
	1 ¹⁵ / ₁₆	1.54	2.48	W2115X	4.64	-	-	-	-	-	-
	2	1.54	2.48	W2200X	4.54	2 - 1 ⁵ / ₈	W2200R110	2 - 1 ⁷ / ₁₆	W2200R107	-	-
	2 ¹ / ₁₆	1.65	2.70	W2201X	4.83	-	-	-	-	-	-
	2 ¹ / ₈	1.65	2.70	W2202X	4.74	-	-	-	-	-	-
	2 ³ / ₁₆	1.65	2.70	W2203X	4.64	2 ³ / ₁₆ - 1 ¹³ / ₁₆	W2203R113	2 ³ / ₁₆ - 1 ⁵ / ₈	W2203R110	2 ³ / ₁₆ - 1 ⁷ / ₁₆	W2203R107
	2 ¹ / ₄	1.75	2.55	W2204X	4.94	-	-	-	-	-	-
2 ⁵ / ₁₆	1.75	2.55	W2205X	4.84	-	-	-	-	-	-	
2 ³ / ₈	1.75	2.55	W2206X	4.72	2 ³ / ₈ - 2	W2206R200	2 ³ / ₈ - 1 ⁷ / ₈	W2206R114	2 ³ / ₈ - 1 ¹³ / ₁₆	W2206R113	
-	-	-	-	-	2 ³ / ₈ - 1 ¹ / ₂	W2206R108	2 ³ / ₈ - 1 ⁷ / ₁₆	W2206R107	2 ³ / ₈ - 1 ⁵ / ₈	W2206R110	

W4000X, Inch-Cassettes & Reducer Inserts

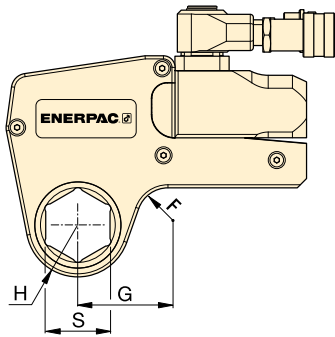

Nominal Torque at 10,000 psi:

4175 ft.lbs

Hexagon Range:

1⁵/₁₆ - 3³/₈ inches

Maximum Operating Pressure:

10,000 psi

W
Series
(X-Edition)



▼ **SELECTION CHART**

Drive Unit Model Number	Hexagon Size	Nose Radius	Dim.	Model Number	Wt.	Hexagon Reducer		Hexagon Reducer		Hexagon Reducer	
						Hexagon Reducer (in)	Model Number	Hexagon Reducer (in)	Model Number	Hexagon Reducer (in)	Model Number
W4000X	1⁵/₁₆	1.46	2.40	W4105X	8.15	-	-	-	-	-	-
	1³/₈	1.46	2.40	W4106X	8.15	-	-	-	-	-	-
	1⁷/₁₆	1.46	2.40	W4107X	8.15	-	-	-	-	-	-
	1¹/₂	1.46	2.40	W4108X	8.31	-	-	-	-	-	-
	1⁹/₁₆	1.46	2.40	W4109X	8.22	-	-	-	-	-	-
	1⁵/₈	1.46	2.40	W4110X	8.15	-	-	-	-	-	-
	1¹¹/₁₆	1.56	2.52	W4111X	8.43	-	-	-	-	-	-
	1³/₄	1.56	2.52	W4112X	8.35	-	-	-	-	-	-
	1¹³/₁₆	1.56	2.52	W4113X	8.25	-	-	-	-	-	-
	1⁷/₈	1.63	2.63	W4114X	8.45	-	-	-	-	-	-
	1¹⁵/₁₆	1.63	2.63	W4115X	8.39	-	-	-	-	-	-
	2	1.63	2.63	W4200X	8.28	2 - 1 ⁷ / ₁₆	W4200R107	-	-	-	-
	2¹/₁₆	1.73	2.89	W4201X	8.65	-	-	-	-	-	-
	2¹/₈	1.73	2.89	W4202X	8.53	-	-	-	-	-	-
	2³/₁₆	1.73	2.89	W4203X	8.42	2 ³ / ₁₆ - 1 ⁵ / ₈	W4203R110	2 ³ / ₁₆ - 1 ⁷ / ₁₆	W4203R107	2 ³ / ₁₆ - 1 ¹ / ₄	W4203R104
	2¹/₄	1.83	2.78	W4204X	8.73	-	-	-	-	-	-
	2⁵/₁₆	1.83	2.78	W4205X	8.61	-	-	-	-	-	-
	2³/₈	1.83	2.78	W4206X	8.47	2 ³ / ₈ - 2	W4206R200	2 ³ / ₈ - 1 ¹³ / ₁₆	W4206R113	2 ³ / ₈ - 1 ⁷ / ₁₆	W4206R107
	-	-	-	-	-	2 ³ / ₈ - 1 ³ / ₈	W4206R106	-	-	-	-
	2⁷/₁₆	1.95	3.00	W4207X	8.96	2 ⁷ / ₁₆ - 2	W4207R200	-	-	-	-
	2¹/₂	1.95	3.00	W4208X	8.86	2 ¹ / ₂ - 2	W4208R200	2 ¹ / ₂ - 1 ¹³ / ₁₆	W4208R113	2 ¹ / ₂ - 2 ¹ / ₁₆	W4208R201
	2⁹/₁₆	1.95	3.00	W4209X	8.67	2 ⁹ / ₁₆ - 2 ³ / ₁₆	W4209R203	2 ⁹ / ₁₆ - 2 ¹ / ₈	W4209R202	-	-
	-	-	-	-	-	2 ⁹ / ₁₆ - 2	W4209R200	2 ⁹ / ₁₆ - 1 ¹³ / ₁₆	W4209R113	-	-
	2⁵/₈	2.07	3.08	W4210X	9.14	-	-	-	-	-	-
	2¹¹/₁₆	2.07	3.08	W4211X	9.03	-	-	-	-	-	-
	2³/₄	2.07	3.08	W4212X	8.84	2 ³ / ₄ - 2 ³ / ₈	W4212R206	2 ³ / ₄ - 2 ³ / ₁₆	W4212R203	2 ³ / ₄ - 2 ¹ / ₈	W4212R202
	2¹³/₁₆	2.18	3.21	W4213X	9.32	-	-	-	-	-	-
	2⁷/₈	2.18	3.21	W4214X	9.17	-	-	-	-	-	-
	2¹⁵/₁₆	2.18	3.21	W4215X	8.96	2 ¹⁵ / ₁₆ - 2 ⁹ / ₁₆	W4215R209	2 ¹⁵ / ₁₆ - 2 ³ / ₈	W4215R206	2 ¹⁵ / ₁₆ - 2 ³ / ₁₆	W4215R203
	-	-	-	-	-	2 ¹⁵ / ₁₆ - 2	W4215R200	-	-	-	-
	3	2.30	3.29	W4300X	9.51	3 - 2 ³ / ₁₆	W4300R203	-	-	-	-
	3¹/₁₆	2.30	3.29	W4301X	9.42	-	-	-	-	-	-
	3¹/₈	2.30	3.29	W4302X	9.16	-	-	3 ¹ / ₈ - 2 ³ / ₄	W4302R212	3 ¹ / ₈ - 2 ⁹ / ₁₆	W4302R209
	-	-	-	-	-	3 ¹ / ₈ - 2 ³ / ₈	W4302R206	3 ¹ / ₈ - 2 ⁵ / ₁₆	W4302R205	3 ¹ / ₈ - 2 ¹ / ₄	W4302R204
	-	-	-	-	-	3 ¹ / ₈ - 2 ³ / ₁₆	W4302R203	3 ¹ / ₈ - 2 ¹ / ₈	W4302R202	3 ¹ / ₈ - 2	W4302R200
	3³/₁₆	2.44	3.37	W4303X	9.92	-	-	-	-	-	-
3¹/₄	2.44	3.37	W4304X	9.92	-	-	-	-	-	-	
3⁵/₁₆	2.44	3.37	W4305X	9.92	-	-	-	-	-	-	
3³/₈	2.44	3.37	W4306X	9.92	-	-	-	-	-	-	

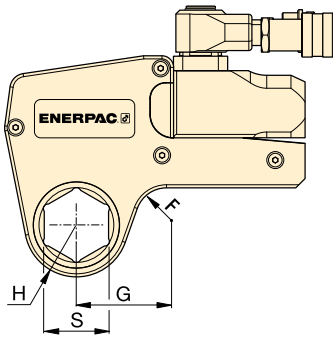

Nominal Torque at 10,000 psi:

8470 ft.lbs

Hexagon Range:

1⁷/₈ - 4¹/₈ inches

Maximum Operating Pressure:

10,000 psi

W
Series
(X-Edition)



▼ SELECTION CHART

Drive Unit Model Number	Hexagon Size	Nose Radius	Dim.	Model Number	Wt.	Image 1		Image 2		Image 3	
						Hexagon Reducer (in)	Model Number	Hexagon Reducer (in)	Model Number	Hexagon Reducer (in)	Model Number
W8000X	S	H	G		(lbs)						
	1 ⁷ / ₈	1.77	3.08	W8114X	17.97	-	-	-	-	-	-
	1 ¹⁵ / ₁₆	1.77	3.08	W8115X	17.89	-	-	-	-	-	-
	2	1.77	3.08	W8200X	17.75	-	-	-	-	-	-
	2 ¹ / ₁₆	1.89	3.15	W8201X	17.52	-	-	-	-	-	-
	2 ¹ / ₈	1.89	3.15	W8202X	17.36	-	-	-	-	-	-
	2 ³ / ₁₆	1.89	3.15	W8203X	17.22	-	-	-	-	-	-
	2 ¹ / ₄	2.01	3.25	W8204X	17.92	-	-	-	-	-	-
	2 ⁵ / ₁₆	2.01	3.25	W8205X	17.76	-	-	-	-	-	-
	2 ³ / ₈	2.01	3.25	W8206X	17.59	-	-	-	-	-	-
	2 ⁷ / ₁₆	2.07	3.38	W8207X	17.65	-	-	-	-	-	-
	2 ¹ / ₂	2.07	3.38	W8208X	17.52	-	-	-	-	-	-
	2 ⁹ / ₁₆	2.07	3.38	W8209X	17.29	2 ⁹ / ₁₆ - 2	W8209R200	-	-	-	-
	2 ⁵ / ₈	2.20	3.34	W8210X	17.50	-	-	-	-	-	-
	2 ¹¹ / ₁₆	2.20	3.34	W8211X	17.36	-	-	-	-	-	-
	2 ³ / ₄	2.20	3.34	W8212X	17.12	2 ³ / ₄ - 2 ³ / ₁₆	W8212R203	-	-	-	-
	2 ¹³ / ₁₆	2.28	3.35	W8213X	17.57	-	-	-	-	-	-
	2 ⁷ / ₈	2.28	3.35	W8214X	17.38	-	-	-	-	-	-
	2 ¹⁵ / ₁₆	2.28	3.35	W8215X	17.11	2 ¹⁵ / ₁₆ - 2 ³ / ₈	W8215R206	2 ¹⁵ / ₁₆ - 2 ³ / ₈	W8215R203	-	-
	3	2.38	3.52	W8300X	17.77	-	-	-	-	-	-
	3 ¹ / ₁₆	2.38	3.52	W8301X	17.65	-	-	-	-	-	-
	3 ¹ / ₈	2.38	3.52	W8302X	17.33	3 ¹ / ₈ - 2 ⁹ / ₁₆	W8302R209	3 ¹ / ₈ - 2 ⁹ / ₁₆	W8302R206	3 ¹ / ₈ - 2 ³ / ₁₆	W8302R203
	-	-	-	-	-	3 ¹ / ₈ - 2	W8302R200	-	-	-	-
	3 ³ / ₁₆	2.60	3.63	W8303X	18.99	-	-	-	-	-	-
	3 ¹ / ₄	2.60	3.63	W8304X	18.72	-	-	-	-	-	-
	3 ⁵ / ₁₆	2.60	3.63	W8305X	18.54	-	-	-	-	-	-
	3 ³ / ₈	2.60	3.63	W8306X	18.36	-	-	-	-	-	-
	3 ⁷ / ₁₆	2.60	3.63	W8307IX	18.11	-	-	-	-	-	-
	3 ¹ / ₂	2.60	3.63	W8308X	17.81	3 ¹ / ₂ - 3	W8308R300	3 ¹ / ₂ - 2 ¹⁵ / ₁₆	W8308R215	3 ¹ / ₂ - 2 ³ / ₄	W8308R212
	3 ⁹ / ₁₆	2.91	4.05	W8309X	20.36	-	-	-	-	-	-
	3 ⁵ / ₈	2.91	4.05	W8310X	20.18	-	-	-	-	-	-
	3 ¹¹ / ₁₆	2.91	4.05	W8311X	19.93	-	-	-	-	-	-
3 ³ / ₄	2.91	4.05	W8312X	19.71	3 ³ / ₄ - 3 ¹ / ₈	W8312R302	3 ³ / ₄ - 2 ¹⁵ / ₁₆	W8312R215	3 ³ / ₄ - 2 ³ / ₄	W8312R212	
3 ¹³ / ₁₆	2.91	4.05	W8313X	19.46	-	-	-	-	-	-	
3 ⁷ / ₈	2.91	4.05	W8314X	19.10	3 ⁷ / ₈ - 3 ¹ / ₈	W8314R302	3 ⁷ / ₈ - 2 ¹⁵ / ₁₆	W8314R215	-	-	
3 ¹⁵ / ₁₆	3.13	4.33	W8315X	20.31	-	-	-	-	-	-	
4	3.13	4.33	W8400X	20.04	-	-	-	-	-	-	
4 ¹ / ₁₆	3.13	4.33	W8401IX	19.80	-	-	-	-	-	-	
4 ¹ / ₈	3.13	4.33	W8402X	19.39	-	-	-	-	-	-	

W15000X, Inch-Cassettes & Reducer Inserts

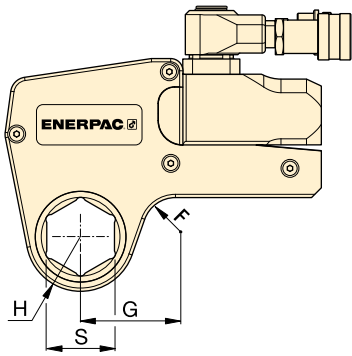

Nominal Torque at 10,000 psi:

15,330 ft.lbs

Hexagon Range:

2⁷/₁₆ - 4⁵/₈ inches

Maximum Operating Pressure:

10,000 psi

W
Series
(X-Edition)



▼ SELECTION CHART

Drive Unit Model Number	Hexagon Size	Nose Radius	Dim. G	Model Number	Wt. (lbs)	Hexagon Reducer		Hexagon Reducer		Hexagon Reducer	
						Hexagon Reducer (in)	Model Number	Hexagon Reducer (in)	Model Number	Hexagon Reducer (in)	Model Number
W15000X	2 ⁷ / ₁₆	2.32	3.49	W15207X	30.72	-	-	-	-	-	-
	2 ¹ / ₂	2.32	3.49	W15208X	30.72	-	-	-	-	-	-
	2 ⁹ / ₁₆	2.32	3.49	W15209X	30.72	-	-	-	-	-	-
	2 ⁵ / ₈	2.32	3.49	W15210X	30.72	-	-	-	-	-	-
	2 ¹¹ / ₁₆	2.32	3.49	W15211X	30.72	-	-	-	-	-	-
	2 ³ / ₄	2.32	3.49	W15212X	30.72	-	-	-	-	-	-
	2 ¹³ / ₁₆	2.44	3.56	W15213X	30.62	-	-	-	-	-	-
	2 ⁷ / ₈	2.44	3.56	W15214X	30.39	-	-	-	-	-	-
	2 ¹⁵ / ₁₆	2.44	3.56	W15215X	30.08	-	-	-	-	-	-
	3	2.54	3.66	W15300X	30.86	3 - 2 ¹ / ₈	W15300R202	-	-	-	-
	3 ¹ / ₁₆	2.54	3.66	W15301X	30.71	-	-	-	-	-	-
	3 ¹ / ₈	2.54	3.66	W15302X	30.34	3 ¹ / ₈ - 2 ⁹ / ₁₆	W15302R209	-	-	-	-
	3 ³ / ₁₆	2.74	3.80	W15303X	32.38	-	-	-	-	-	-
	3 ¹ / ₄	2.74	3.80	W15304X	32.07	-	-	-	-	-	-
	3 ⁵ / ₁₆	2.74	3.80	W15305X	31.85	-	-	-	-	-	-
	3 ³ / ₈	2.74	3.80	W15306X	31.63	-	-	-	-	-	-
	3 ⁷ / ₁₆	2.74	3.80	W15307IX	31.32	-	-	-	-	-	-
	3 ¹ / ₂	2.74	3.80	W15308X	30.98	3 ¹ / ₂ - 2 ¹⁵ / ₁₆	W15308R215	3 ¹ / ₂ - 2 ³ / ₄	W15308R212	-	-
	3 ⁹ / ₁₆	2.95	4.01	W15309X	31.70	-	-	-	-	-	-
	3 ⁵ / ₈	2.95	4.01	W15310X	31.70	-	-	-	-	-	-
	3 ¹¹ / ₁₆	2.95	4.01	W15311X	31.70	-	-	-	-	-	-
	3 ³ / ₄	2.95	4.01	W15312X	31.70	3 ³ / ₄ - 3 ¹ / ₈	W15312R302	3 ³ / ₄ - 2 ¹⁵ / ₁₆	W15312R215	-	-
	3 ¹³ / ₁₆	2.95	4.01	W15313X	31.70	-	-	-	-	-	-
	3 ⁷ / ₈	2.95	4.01	W15314X	31.70	3 ⁷ / ₈ - 3 ¹ / ₈	W15314R302	3 ⁷ / ₈ - 2 ¹⁵ / ₁₆	W15314R215	-	-
	3 ¹⁵ / ₁₆	3.17	4.06	W15315X	34.02	-	-	-	-	-	-
	4	3.17	4.06	W15400X	33.70	-	-	-	-	-	-
	4 ¹ / ₁₆	3.17	4.06	W15401IX	33.41	-	-	-	-	-	-
	4 ¹ / ₈	3.17	4.06	W15402X	33.09	4 ¹ / ₈ - 3 ¹ / ₂	W15402R308	4 ¹ / ₈ - 3 ⁵ / ₁₆	W15402R305	4 ¹ / ₈ - 3 ¹ / ₄	W15402R304
	4 ³ / ₁₆	3.17	4.06	W15403IX	32.81	-	-	-	-	-	-
	4 ¹ / ₄	3.17	4.06	W15404X	32.29	4 ¹ / ₄ - 3 ¹ / ₂	W15404R308	4 ¹ / ₄ - 3 ¹ / ₈	W15404R302	-	-
	4 ⁵ / ₁₆	3.44	4.52	W15405X	35.61	-	-	-	-	-	-
	4 ³ / ₈	3.44	4.52	W15406X	35.32	-	-	-	-	-	-
4 ⁷ / ₁₆	3.44	4.52	W15407X	34.99	-	-	-	-	-	-	
4 ¹ / ₂	3.44	4.52	W15408IX	34.63	-	-	-	-	-	-	
4 ⁹ / ₁₆	3.44	4.52	W15409IX	34.28	-	-	-	-	-	-	
4 ⁵ / ₈	3.44	4.52	W15410IX	33.72	4 ⁵ / ₈ - 3 ¹⁵ / ₁₆	W15410R315	4 ⁵ / ₈ - 3 ⁷ / ₈	W15410R314	4 ⁵ / ₈ - 3 ³ / ₄	W15410R312	
-	-	-	-	-	-	4 ⁵ / ₈ - 3 ¹ / ₂	W15410R308	-	-	-	

W22000X, Inch-Cassettes & Reducer Inserts **ENERPAC**

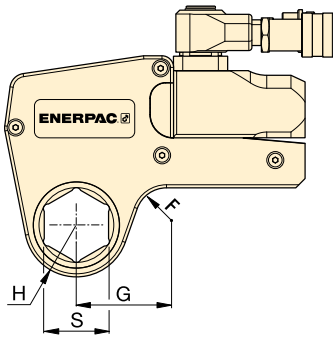

Nominal Torque at 10,000 psi:

22,500 ft.lbs

Hexagon Range:

2¹⁵/₁₆ - 5³/₈ inches



Maximum Operating Pressure:

10,000 psi

W
Series
(X-Edition)



▼ SELECTION CHART

Drive Unit Model Number	Hexagon Size	Nose Radius	Dim.	Model Number	Wt.						
						Hexagon Reducer (in)	Model Number	Hexagon Reducer (in)	Model Number	Hexagon Reducer (in)	Model Number
W22000X	2¹⁵/₁₆	2.64	4.02	W22215X	48.72	-	-	-	-	-	-
	3	2.64	4.02	W22300X	48.40	-	-	-	-	-	-
	3¹/₁₆	2.64	4.02	W22301X	48.22	-	-	-	-	-	-
	3¹/₈	2.64	4.02	W22302X	47.78	3 ¹ / ₈ - 2 ³ / ₈	W22302R206	3 ¹ / ₈ - 2 ³ / ₁₆	W22302R203	-	-
	3³/₁₆	2.85	4.23	W22303X	50.58	-	-	-	-	-	-
	3¹/₄	2.85	4.23	W22304X	50.19	-	-	-	-	-	-
	3⁵/₁₆	2.85	4.23	W22305X	49.92	-	-	-	-	-	-
	3³/₈	2.85	4.23	W22306X	49.66	-	-	-	-	-	-
	3⁷/₁₆	2.85	4.23	W22307X	50.29	-	-	-	-	-	-
	3¹/₂	2.85	4.23	W22308X	48.87	3 ¹ / ₂ - 2 ³ / ₄	W22308R212	3 ¹ / ₂ - 2 ⁹ / ₁₆	W22308R209	3 ¹ / ₂ - 2 ³ / ₈	W22308R206
	3⁹/₁₆	3.07	4.45	W22309X	51.58	-	-	-	-	-	-
	3⁵/₈	3.07	4.45	W22310X	51.30	-	-	-	-	-	-
	3¹¹/₁₆	3.07	4.45	W22311X	50.93	-	-	-	-	-	-
	3³/₄	3.07	4.45	W22312X	50.62	3 ³ / ₄ - 2 ¹⁵ / ₁₆	W22312R215	-	-	-	-
	3¹³/₁₆	3.07	4.45	W22313X	50.24	-	-	-	-	-	-
	3⁷/₈	3.07	4.45	W22314X	49.77	3 ⁷ / ₈ - 3 ¹ / ₈	W22314R302	3 ⁷ / ₈ - 2 ¹⁵ / ₁₆	W22314R215	3 ⁷ / ₈ - 2 ³ / ₄	W22314R212
	3¹⁵/₁₆	3.35	4.72	W22315X	53.57	-	-	-	-	-	-
	4	3.35	4.72	W22400X	53.19	-	-	-	-	-	-
	4¹/₁₆	3.35	4.72	W22401IX	52.82	-	-	-	-	-	-
	4¹/₈	3.35	4.72	W22402X	52.43	-	-	-	-	-	-
	4³/₁₆	3.35	4.72	W22403X	52.09	-	-	-	-	-	-
	4¹/₄	3.35	4.72	W22404X	51.48	4 ¹ / ₄ - 3 ¹ / ₂	W22404R308	4 ¹ / ₄ - 3 ¹ / ₈	W22404R302	4 ¹ / ₄ - 2 ¹⁵ / ₁₆	W22404R215
	4⁵/₁₆	3.54	4.92	W22405X	54.26	-	-	-	-	-	-
	4³/₈	3.54	4.92	W22406X	53.91	-	-	-	-	-	-
	4⁷/₁₆	3.54	4.92	W22407X	53.50	-	-	-	-	-	-
	4¹/₂	3.54	4.92	W22408IX	53.06	-	-	-	-	-	-
	4⁹/₁₆	3.54	4.92	W22409X	52.64	-	-	-	-	-	-
	4⁵/₈	3.54	4.92	W22410IX	51.99	4 ⁵ / ₈ - 3 ⁷ / ₈	W22410R314	4 ⁵ / ₈ - 3 ³ / ₄	W22410R312	4 ⁵ / ₈ - 3 ¹ / ₂	W22410R308
	4³/₄	3.74	5.12	W22412X	54.54	-	-	-	-	-	-
	4⁷/₈	3.74	5.12	W22414X	53.60	-	-	-	-	-	-
	5	3.74	5.12	W22500X	52.37	5 - 4 ¹ / ₄	W22500R404	5 - 4 ¹ / ₈	W22500R402	5 - 3 ⁷ / ₈	W22500R314
	5¹/₈	3.94	5.31	W22502X	55.10	-	-	-	-	-	-
5¹/₁₆	3.94	5.31	W22503X	54.71	-	-	-	-	-	-	
5¹/₄	3.94	5.31	W22504X	54.05	-	-	-	-	-	-	
5³/₈	3.94	5.31	W22506X	52.77	5 ³ / ₈ - 4 ⁵ / ₈	W22506R410	5 ³ / ₈ - 4 ¹ / ₄	W22506R404	5 ³ / ₈ - 4 ¹ / ₈	W22506R402	
-	-	-	W22506X	52.77	5 ³ / ₈ - 3 ⁷ / ₈	W22506R314	-	-	-	-	

W35000X, Inch-Cassettes & Reducer Inserts

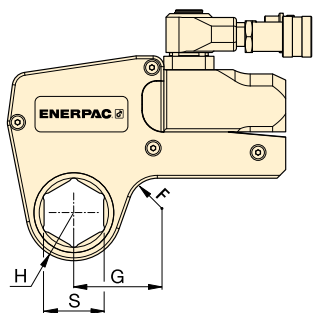

▼ SELECTION CHART

Drive Unit Model Number	Hexagon Size	Nose Radius	Dim.	Model Number	Wt.	Image	
						Hexagon Reducer (in)	Model Number
	S (in)	H (in)	G (in)		(lbs)		
W35000X	3 ¹ / ₈	3.02	4.99	W35302X	72.30	3 ¹ / ₈ - 2	W35302R200
	3 ³ / ₁₆	3.02	4.99	W35303X	72.10	-	-
	3 ¹ / ₄	3.02	4.99	W35304X	71.70	-	-
	3 ⁵ / ₁₆	3.02	4.99	W35305X	71.40	-	-
	3 ³ / ₈	3.02	4.99	W35306X	71.00	-	-
	3 ⁷ / ₁₆	3.02	4.99	W35307IX	70.50	-	-
	3 ¹ / ₂	3.02	4.99	W35308X	70.10	3 ¹ / ₂ - 2 ⁵ / ₁₆	W35308R205
	3 ⁹ / ₁₆	3.23	5.22	W35309X	71.40	-	-
	3 ⁵ / ₈	3.23	5.22	W35310X	73.40	-	-
	3 ¹¹ / ₁₆	3.23	5.22	W35311X	73.00	-	-
	3 ³ / ₄	3.23	5.22	W35312X	72.50	-	-
	3 ¹³ / ₁₆	3.23	5.22	W35313X	72.10	-	-
	3 ⁷ / ₈	3.23	5.22	W35314X	71.40	3 ⁷ / ₈ - 2 ¹¹ / ₁₆	W35314R211
	3 ¹⁵ / ₁₆	3.45	5.39	W35315X	70.80	3 ¹⁵ / ₁₆ - 2 ¹³ / ₁₆	W35315R213
	4	3.45	5.39	W35400X	74.70	-	-
	4 ¹ / ₁₆	3.45	5.39	W35401X	74.30	-	-
	4 ¹ / ₈	3.45	5.39	W35402X	73.90	-	-
	4 ³ / ₁₆	3.45	5.39	W35403X	73.40	-	-
	4 ¹ / ₄	3.45	5.39	W35404X	72.80	4 ¹ / ₄ - 3 ¹⁵ / ₁₆	W35404R301
	4 ⁵ / ₁₆	3.69	5.63	W35405X	76.90	-	-
	4 ³ / ₈	3.69	5.63	W35406X	76.50	-	-
	4 ⁷ / ₁₆	3.69	5.63	W35407X	76.10	-	-
	4 ¹ / ₂	3.69	5.63	W35408X	75.60	-	-
	4 ⁹ / ₁₆	3.69	5.63	W35409IX	75.20	-	-
	4 ⁵ / ₈	3.69	5.63	W35410IX	74.50	4 ⁵ / ₈ - 3 ⁵ / ₈	W35410R310
	4 ³ / ₄	3.91	5.85	W35412X	78.50	4 ³ / ₄ - 3 ³ / ₄	W35412R312
	4 ⁷ / ₈	3.91	5.85	W35414X	76.90	-	-
	5	3.91	5.85	W35500X	75.60	5 - 4	W35500R400
	5 ¹ / ₈	4.09	6.02	W35502X	78.90	5 ¹ / ₈ - 4 ¹ / ₈	W35502R402
	5 ³ / ₁₆	4.09	6.02	W35503X	78.50	-	-
	5 ¹ / ₄	4.09	6.02	W35504X	77.60	-	-
	5 ³ / ₈	4.09	6.02	W35506X	76.30	5 ³ / ₈ - 4 ⁵ / ₁₆	W35506R405
5 ¹ / ₂	4.31	6.24	W35508X	79.80	-	-	
5 ⁹ / ₁₆	4.31	6.24	W35509X	79.40	-	-	
5 ⁵ / ₈	4.31	6.24	W35510X	78.50	-	-	
5 ³ / ₄	4.31	6.24	W35512X	76.90	5 ³ / ₄ - 4 ³ / ₄	W35512R412	
5 ⁷ / ₈	4.52	6.46	W35514X	80.90	5 ⁷ / ₈ - 4 ⁷ / ₈	W35514R414	
6	4.52	6.46	W35600X	79.60	-	-	
6 ¹ / ₈	4.52	6.46	W35602X	77.80	6 ¹ / ₈ - 5 ¹ / ₈	W35602R502	

W Series (X-Edition)



Nominal Torque at 10,000 psi:

35,000 ft.lbs

Hexagon Range:

3¹/₈ - 6¹/₈ inches

Maximum Operating Pressure:

10,000 psi



Back-Up Spanners

Hands free tool to be used to stop back nut from turning during make up or break out.

Page: 245



Hexagon Bolt and Nut Sizes

See the table of hexagon sizes of bolts, nuts and related thread diameters.

Page: 411

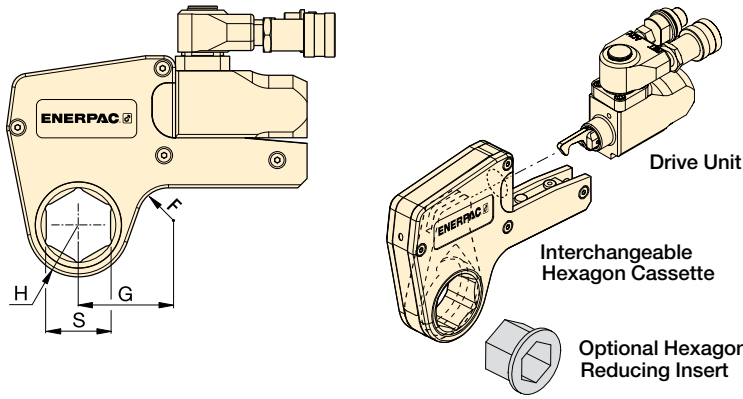

W
Series
(X-Edition)



Hexagon Range:

24 - 105 mm

Maximum Operating Pressure:

10,000 psi (690 bar)

▼ SELECTION CHART

Drive Unit Model Number	Hexagon Size* S (mm)	Nose Radius H (in)	Dim. G (in)	Model Number	Wt. (lbs)	Hexagon Reducer		Hexagon Reducer		Hexagon Reducer		
						Hexagon Reducer (mm)	Model Number	Hexagon Reducer (mm)	Model Number	Hexagon Reducer (mm)	Model Number	
W2000X	30	1.22	2.11	W2103X	4.19	-	-	-	-	-	-	
	32	1.22	2.11	W2104X	4.19	-	-	-	-	-	-	
	36	1.22	2.11	W2107X	4.19	-	-	-	-	-	-	
	38	1.32	2.29	W2108X	4.51	-	-	-	-	-	-	
	41	1.32	2.29	W2110X	4.38	41 - 32	W2110R104	41 - 30	W2110R103	41 - 24	W2110R024M	
	46	1.44	2.38	W2113X	4.69	46 - 36	W2113R107	46 - 32	W2113R104	-	-	
	50	1.54	2.48	W2200X	4.54	50 - 41	W2200R110	50 - 36	W2200R107	-	-	
	55	1.65	2.70	W2203X	4.64	55 - 46	W2203R113	55 - 41	W2203R110	55 - 36	W2203R107	
	60	1.75	2.55	W2206X	4.72	60 - 50	W2206R200	60 - 46	W2206R113	60 - 41	W2206R110	
-	-	-	-	-	-	60 - 36	W2206R107	-	-	-	-	
W4000X	36	1.46	2.40	W4107X	7.72	-	-	-	-	-	-	
	41	1.46	2.40	W4110X	7.72	-	-	-	-	-	-	
	46	1.56	2.52	W4113X	7.94	-	-	-	-	-	-	
	50	1.63	2.63	W4200X	8.28	50 - 36	W4200R107	-	-	-	-	
	55	1.73	2.89	W4203X	8.42	55 - 41	W4203R110	55 - 36	W4203R107	55 - 32	W4203R104	
	60	1.83	2.78	W4206X	8.47	60 - 50	W4206R200	60 - 46	W4206R113	60 - 36	W4206R107	
	65	1.95	3.00	W4209X	8.67	65 - 55	W4209R203	65 - 50	W4209R200	65 - 46	W4209R113	
	70	2.07	3.08	W4212X	8.84	70 - 60	W4212R206	70 - 55	W4212R203	-	-	
	75	2.18	3.21	W4215X	8.96	75 - 65	W4215R209	75 - 60	W4215R206	-	-	
	-	-	-	-	-	-	75 - 55	W4215R203	75 - 50	W4215R200	-	-
	80	2.30	3.29	W4302X	9.16	80 - 75	W4302R215	80 - 70	W4302R212	80 - 65	W4302R209	
	-	-	-	-	-	-	80 - 55	W4302R203	80 - 50	W4302R200	-	-
W8000X	50	1.77	3.08	W8200X	17.75	-	-	-	-	-	-	
	55	1.89	3.15	W8203X	17.22	-	-	-	-	-	-	
	60	2.01	3.25	W8206X	17.59	-	-	-	-	-	-	
	65	2.07	3.38	W8209X	17.29	65 - 50	W8209R200	-	-	-	-	
	70	2.07	3.34	W8212X	17.12	70 - 55	W8212R203	-	-	-	-	
	75	2.28	3.35	W8215X	17.11	75 - 60	W8215R206	75 - 55	W8215R203	-	-	
	80	2.38	3.52	W8302X	17.33	80 - 65	W8302R209	80 - 60	W8302R206	80 - 55	W8302R203	
	-	-	-	-	-	-	80 - 50	W8302R200	-	-	-	
	85	2.60	3.63	W8085MX	18.42	85 - 70	W8085R070M	85 - 65	W8085R065M	85 - 60	W8085R060M	
	-	-	-	-	-	-	85 - 55	W8085R055M	-	-	-	
	90	2.91	4.05	W8090MX	20.46	90 - 75	W8090R075M	-	-	-	-	
	95	2.91	4.05	W8312X	19.71	95 - 80	W8312R302	95 - 75	W8312R215	-	-	
100	3.13	4.33	W8315X	20.31	-	-	-	-	-	-		
105	3.13	4.33	W8402X	19.39	-	-	-	-	-	-		

* See page 411 for table of hexagon sizes of bolts, nuts and related thread diameters.

W-Series, Metric Cassettes and Reducer Inserts

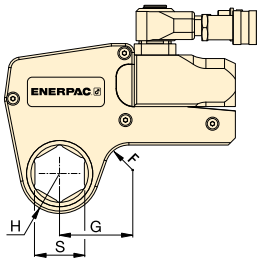

Hexagon Range:
50 - 155 mm

Maximum Operating Pressure:
10,000 psi (690 bar)

W
Series
(X-Edition)



▼ SELECTION CHART

Drive Unit Model Number	Hexagon Size	Nose Radius	Dim.	Model Number	Wt.	Hexagon Reducer		Hexagon Reducer	
						Hexagon Reducer (mm)	Model Number	Hexagon Reducer (mm)	Model Number
W15000X	S (mm)	H (in)	G (in)		(lbs)				
	65	2.32	3.49	W15209X	30.72	-	-	-	-
	70	2.32	3.49	W15212X	30.72	-	-	-	-
	75	2.44	3.56	W15215X	30.08	-	-	-	-
	80	2.54	3.66	W15302X	30.34	80-65	W15302R209	-	-
	85	2.74	3.80	W15085MX	31.70	85-70	W15085R070M	-	-
	90	2.95	4.01	W15090MX	33.32	90-75	W15090R075M	-	-
	95	2.95	4.01	W15312X	31.70	95-80	W15312R302	95 - 75	W15312R215
	100	3.17	4.06	W15315X	34.02	-	-	-	-
	105	3.17	4.06	W15402X	33.09	105-90	W15402R090M	-	-
	110	3.44	4.52	W15405X	35.61	110-95	W15110R095M	-	-
115	3.44	4.52	W15115MX	34.48	115-100	W15115R100M	-	-	
W22000X	75	2.64	4.02	W22215X	48.72	-	-	-	-
	80	2.64	4.02	W22302X	47.78	80-60	W22302R206	80 - 55	W22302R203
	85	2.85	4.23	W22085MX	49.74	85-65	W22085MR209	85 - 60	W22085MR206
	90	3.07	4.45	W22090MX	51.72	90-70	W22090M212	90 - 60	W22090MR206
	95	3.07	4.45	W22312X	50.62	95-75	W22312R215	-	-
	100	3.35	4.72	W22315X	53.57	-	-	-	-
	105	3.35	4.72	W22402X	52.09	-	-	-	-
	110	3.54	4.92	W22404X	51.48	-	-	-	-
	115	3.54	4.92	W22115MX	52.88	-	-	-	-
	120	3.74	5.12	W22412X	54.54	-	-	-	-
	123	3.74	5.12	W22123MX	53.80	-	-	-	-
	130	3.94	5.31	W22502X	55.10	-	-	-	-
	135	3.94	5.31	W22506X	52.77	135-105	W22506R402	-	-
W35000X	80	3.02	5.08	W35302X	72.30	80-50	W35302R200	-	-
	85	3.02	5.08	W35085MX	33.10	-	-	-	-
	90	3.23	5.33	W35090MX	34.30	90-60	W35090R206	-	-
	95	3.23	5.30	W35312X	72.50	-	-	-	-
	100	3.45	5.48	W35315X	70.80	-	-	-	-
	105	3.45	5.48	W35402X	73.90	-	-	-	-
	110	3.69	5.75	W35405X	76.90	110-85	W35405R085M	-	-
	115	3.69	5.75	W35115MX	77.10	-	-	-	-
	120	3.91	6.01	W35412X	78.50	120-95	W35412R312	-	-
	123	3.91	6.01	W35123MX	78.90	-	-	-	-
	130	4.09	6.30	W35502X	78.90	130-105	W35502R402	-	-
	135	4.09	6.30	W35506X	76.30	135-110	W35506R405	-	-
	140	4.31	6.43	W35508X	79.80	140-115	W35508R115M	-	-
	145	4.31	6.43	W35512X	76.90	145-120	W35512R412	-	-
	150	4.52	6.67	W35514X	80.90	-	-	-	-
	151	4.52	6.67	W35151MX	82.10	-	-	-	-
	155	4.52	6.67	W35602X	77.80	155-130	W35602R502	-	-

▼ Shown: W4206SL stepped-width cassette with W4000X drive unit



Your Easy and Long-Lasting Solution to Difficult Access Bolting Applications



Designed for Tight Spots
Stepped width design provides easy access in confined areas. UltraSlim cassettes fit where standard solutions won't.



Built to Outperform
High endurance components keep working when others fail.



Top Mounted Handles
Standard top mounted handles provide safety and versatility; optional angled handles are also available.

Replacement handle (straight)	SWH6S
Angled handle (optional)	SWH6A

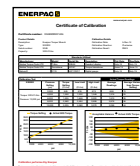

Calibration Certificate
All UltraSlim Series cassettes are CE - ATEX certified, factory calibrated and are shipped complete with a calibration certificate.

CE II 2 GD T4
CSA/SIRA 15XT072



Versatility

- Lean, stepped width design allows tool to be mounted over bolts where other tools won't fit
- Bi-Hexagonal cassette allows twice as many positioning points on nut or bolt
- Uses same drive unit as standard W-series hexagon cassettes
- Robust top mounted handle stays out of the way, providing safe fastening in hard to reach areas

Performance

- Premium components provide best-in-class endurance

Ease of Use

- Few moving parts are easily accessible for quick field maintenance
- Fast release drive unit enables rapid exchange of cassettes, no tools required and no pins to lose
- Uses same drive unit as standard and X-Edition cassettes

Accuracy

- Constant torque output provides accuracy of +/- 3% across the full stroke

Slim enough to fit and tough enough to last. This UltraSlim wrench is the perfect controlled bolting solution for this oil and gas flange. ▶

UltraSlim Stepped-Width Cassettes



UltraSlim Stepped-Width Cassettes

Accessing narrow spaces normally requires significantly reducing the width of the torque wrench. For the tool operator, this has always meant vastly reduced tool durability, and/or reduced torque output.

By using the highest-grade materials, perfecting the geometry, and placing the positioning handle on top of the tool, Enerpac UltraSlim cassettes are able to provide greater torque, get into tighter spaces, and vastly outperform the competition in product durability.*

Durability of Key Components*

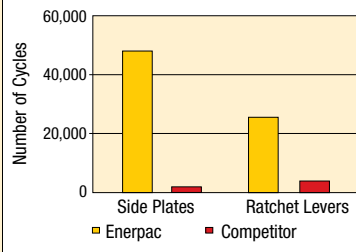

*Average test results, whereby three Enerpac 1³/₁₆" UltraSlim cassettes and three competitor 1³/₁₆" cassettes were tested at 4000 ft-lbs for 50,000 cycles. The Enerpac side plates never broke for the full duration of the test.

W-SL Series Ultra-Slim



Nominal Torque at 10,000 psi:

4360 Ft.lbs.

Hexagon Range:

1¹³/₁₆ - 2¹⁵/₁₆ inches

Maximum Operating Pressure:

10,000 psi



Torque Wrench Pumps

Visit enerpac.com for system matched air and electric torque wrench pumps that are ideal for use with hydraulic torque wrenches.

Page: 291

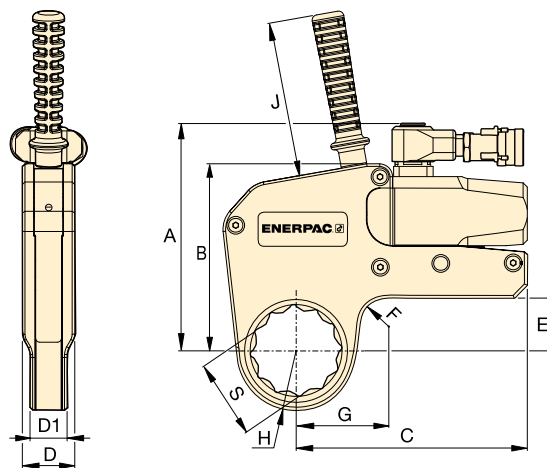

Torque Wrench Hoses

Use Enerpac THQ-Series hoses with W-Series torque wrenches to ensure the integrity of your hydraulic system.

10,000 psi	
6 feet long, 2 hoses	THQ702T
19.5 feet long, 2 hoses	THQ706T
39 feet long, 2 hoses	THQ712T

▼ SELECTION CHART

Hexagon Size	Nominal Torque @ 10,000 psi	Cassette Model Number *	Minimum Torque @ 1000 psi	Nose Radius	Dimensions (in)									Weight (lbs)	Drive Unit Model ** (sold separately)			
					S	H	G	A	B	C	D	D1	E			F	J	
1 ³ / ₁₆	1980	W2113SL	200	1.44	2.35													
2	1980	W2200SL	200	1.52	2.40													
2 ³ / ₁₆	1980	W2203SL	200	1.63	2.49	5.54	4.30	5.81	1.28	1.00	0.94	0.79	4.72	4.87	W2000X			
2 ³ / ₈	1980	W2206SL	200	1.75	2.56									4.88				
1 ³ / ₁₆	4360	W4113SL	430	1.56	2.65									10.15		W4000X		
2 ³ / ₁₆	4360	W4203SL	430	1.73	2.70									10.15				
2 ³ / ₈	4360	W4206SL	430	1.89	2.82	6.91	5.69	7.03	1.59	1.13	1.61	0.79	4.72	10.36				
2 ⁹ / ₁₆	4360	W4209SL	430	1.99	2.92									10.37				
2 ³ / ₄	4360	W4212SL	430	2.11	2.98									10.42				
2 ¹⁵ / ₁₆	4360	W4215SL	430	2.20	2.99									10.37				

* Bi-Hexagonal Cassette includes top mounted straight handle.

** May also be used with W2000PX and W4000PX drive units, featuring double-swivel manifolds.

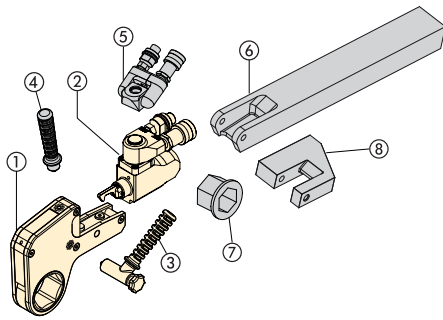

- ① Hexagon Cassette
- ② Drive Unit
- ③ Angled Positioning Handle
- ④ Straight Positioning Handle (optional)
- ⑤ Pro Series Swivel (optional)
- ⑥ Extended Reaction Arm (optional)
- ⑦ Reducer Insert (optional)
- ⑧ Reaction Paddle (optional)

TSP WTE WRP Series



TSP-Series, Pro Series Swivels

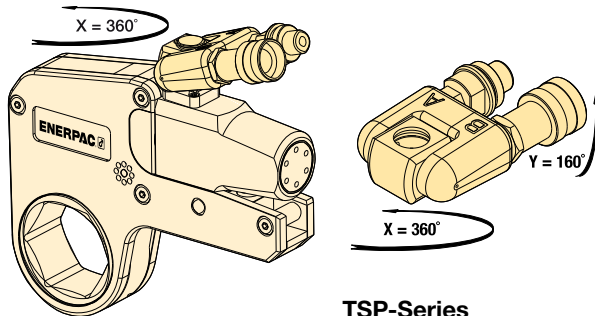

TSP-Series

- Robust interlocking design
- 360° X-axis and 160° Y-axis rotation
- Increases tool fit in restricted access areas
- Simplifies hose placement
- Includes male and female couplers

Torque Wrench Model Number	Model Number	Maximum Pressure (psi)	Wt. (lbs)
W2000X, W4000X, W8000X, W15000X, W22000X, W35000X	TSP300*	10,000	0.44

Note: To order a W-series (X-Edition) wrench fitted with the TSP swivel, insert a "P" prior to the "X" in the tool designation, e.g., W2000PX.

* TSP300 is designed for X-Edition tools only, and is not compatible with standard edition tools. For replacement components for existing tools, refer to repair sheet on www.enerpac.com

WTE-Series, Extended Reaction Arm

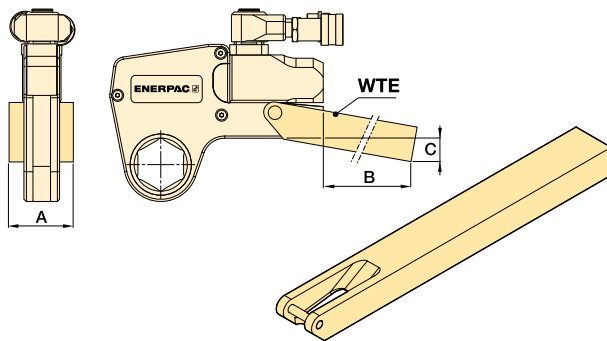

WTE-Series

- Full torque rated
- Increases tool fit in restricted access areas

Torque Wrench Model Number	Model Number	Dimensions (in)			Wt.* (lbs)
		A	B	C	
W2000X	WTE20	2.20	15.67	2.66	5.73
W4000X	WTE40	2.60	17.17	2.91	10.14
W8000X	WTE80	3.35	17.68	2.15	16.76
W15000X	WTE150	4.02	19.61	2.83	26.46
W22000X	WTE220	4.49	20.51	3.03	38.14
W35000X	WTE350	5.00	16.48	5.23	39.24

* Weights indicated are for the accessories only and do not include the wrench.

WRP-Series Reaction Paddles

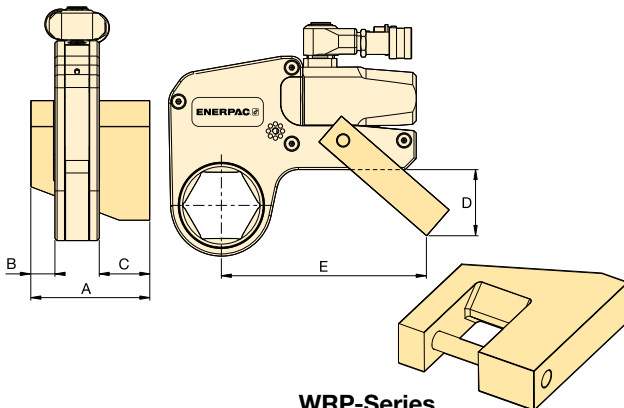

WRP-Series

- Lightweight interchangeable design
- Allows for offset reaction when in-line reaction is not available

Torque Wrench Model Number	Model Number	Dimensions (in)					Wt.* (lbs)
		A	B	C	D	E	
W2000X	WRP20	3.31	0.63	1.40	1.77	5.83	0.88
W4000X	WRP40	4.29	0.83	1.87	2.32	7.48	1.76
W8000X	WRP80	5.37	1.02	2.25	2.72	8.78	4.41
W15000X	WRP150	6.50	1.26	2.74	3.43	10.12	8.60
W22000X	WRP220	8.15	1.52	3.58	5.28	12.48	15.87
W35000X	WRP350	9.22	1.79	3.58	7.17	13.98	23.37

* Weights indicated are for the accessories only and do not include the wrench.

ENERPAC professional series steel torque wrenches provide reliable controlled tightening solutions across many industries.

S3000X Square Drive Torque Wrench on Wind Turbine Assembly and Maintenance

S3000X used to connect wind turbine segments during assembly and maintenance. A robust but compact solution is required for bolt tightening on wind tower sections. Large numbers of fasteners require precise application of torque to ensure joint integrity is achieved and maintained.

The Enerpac S-Series wrench offers simple and reliable operation while providing accurate and repeatable results.



W4000X Low-Profile Torque Wrench on an API Pipe Flange

Throughout the Oil and Gas, Petrochemical and Processing Industries, pipeline joints, valves, pumps and machinery present challenges for controlled bolting.

The restricted access on this flange was easily overcome with an Enerpac W-Series Torque Wrench. The W Wrenches offer reliability and control, ensuring even and consistent torque is applied to all bolts.

S3000X on an Oil and Gas Flange

During maintenance, quick turnaround times are essential; S-Series wrenches provide a large angle of nut rotation per stroke, offering speed and accuracy in a compact ergonomic tool.



▼ RSL Drive Units with interchangeable RLP Hexagon Cassette and RSQ Square Drive Cassette



Setting New Standards in Safety, Simplicity and Performance

Safety and Performance

- Innovative design that completely encloses all moving parts and minimizes pinch points
- 30-35° rotation angle provides added productivity while avoiding "tool lock-on" which is common with some torque wrench designs

Simplicity

- Simple robust alloy steel design with just three moving parts for reduced maintenance
- Robust handles are available for both sides and the tops of cassettes to allow for extra maneuverability
- Designed to give optimum strength-to-weight and torque-to-weight ratios
- Minimum nose radius for trouble-free tool fit

Versatility

- Interchangeable cassette design
- Wide range of hexagon sizes available for all applications
- Reaction arm has a simple dial lock for rapid change
- For use in multiple industrial, energy, and oil and gas applications

Accuracy

- Constant torque output provides accuracy of +/-3% across full stroke



RLP-Series, Low-Profile Hexagon Cassettes

For metric and imperial hexagon cassettes see pages 264-268.

Page: 264



RSQ-Series, Square-Drive Heads

RSQ Square Drive Heads are interchangeable with the RLP Hexagon Cassettes for the same size RSL Drive Unit.

Page: 272



Back-Up Spanner

To be used to stop back nut from turning during make up or break out. Two hex sizes in one tool.

Page: 245



Torque Wrench Pumps

Visit enerpac.com for system-matched air and electric torque wrench pumps that are ideal for use with hydraulic torque wrenches.

Page: 291



Torque Wrench Hoses

Use Enerpac THQ700 Series hoses with RSL-Series torque wrenches to ensure the integrity of your hydraulic system.

6 feet long, 2 hoses	THQ702T
19.5 feet long, 2 hoses	THQ706T
39 feet long, 2 hoses	THQ712T

Drive Units for Hexagon & Square Drive Cassettes



One Drive, Two Tools

One RSL-Hydraulic Drive Unit fits RLP-Hexagon Cassette or RSQ-Square Drive Head.

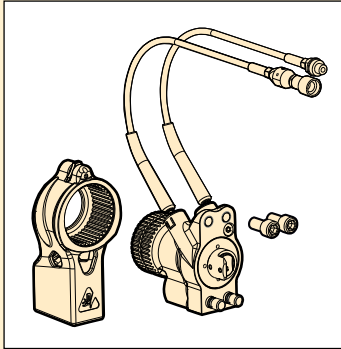

RSL

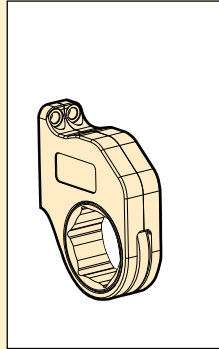

RLP... / RLP...SL

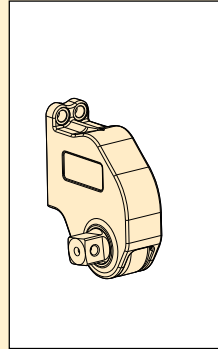

RSQ

RSL Series



Maximum Torque Output:

1408 - 28,002 Ft-lbs

Hexagon Range:

7/8 - 6 1/8 inches

Hexagon Range:

26 - 155 mm

Maximum Operating Pressure:

10,000 psi

▼ TORQUE WRENCH OPTIONS AND ACCESSORIES

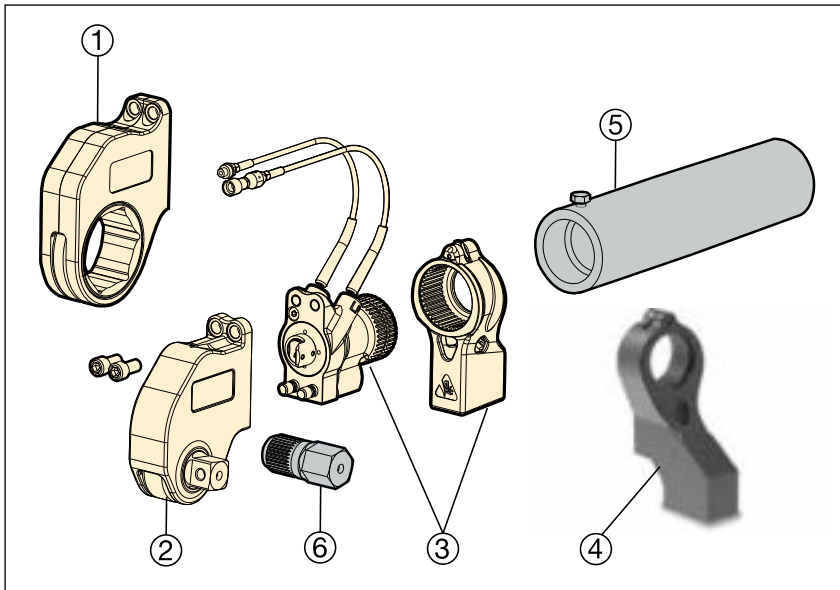

- ① **RLP-Hexagon Cassette** (pages 264-268)
RLP-SL-Slimline Hexagon Cassette (pages 270-271)
- ② **RSQ-Square Drive Cassette** (pages 272-273)
- ③ **RSL-Drive Unit and Reaction Arm** (page 263)

Optional Parts (page 269)

- ④ **ERA-Extended Reaction Arm**, for RSQ only
- ⑤ **ERT-Extended Reaction Tube**, for RLP only

Optional Parts (only available per request)

- ⑥ **Hexagon Bit**

▼ SELECTION CHART

Hexagon Cassette Range (A/F) (see pages 264 - 268 for sizes and model numbers)		Maximum Torque Output at 10,000 psi		Drive Unit Model Number	Minimum Torque Output at 1000 psi		
(inch)	(mm)	(Ft.lbs)	(Nm)		(Ft.lbs)	(Nm)	
7/8 - 2 3/8	26 - 60	1408	1909	RSL1500	141	191	3.4
1 5/16 - 2 15/16	33 - 75	3080	4176	RSL3000	308	417	5.6
1 11/16 - 3 1/8	46 - 80	5303	7190	RSL5000	530	719	8.9
2 3/8 - 3 1/8	60 - 80	7862	10,659	RSL8000	786	1066	10.6
2 7/16 - 4 5/8	62 - 110	11,154	15,123	RSL11000	1115	1512	11.6
2 15/16 - 4 5/8	75 - 115	18,843	25,547	RSL19000	1884	2554	20.0
3 1/8 - 6 1/8	80 - 155	28,002	37,965	RSL28000	2800	3796	22.0



Bolting Integrity Software

Enerpac Bolting Integrity Software Solutions play a key role in implementing and managing an Integrity Program for bolted connections. The software offers Tool selection, Bolt Load calculations and Tool pressure settings, as well as, a combined Application Data Sheet and Joint Completion Report. Custom Joint information can also be entered.

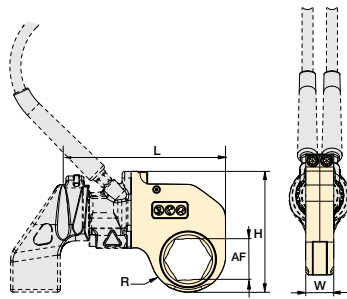

Hexagon Range:
7/8 - 6 1/8 inches

Hexagon Range:
26 - 155 mm

Maximum Operating Pressure:
10,000 psi

**RSL
Series**



▼ **SELECTION CHART**

Drive Unit Model Number	Hexagon Size A/F		Hexagon Cassette Model Number	Maximum Torque Output		Dimensions (in)				Wt. (lbs)	Dimensions (mm)				Wt. (kg)	
	(in)	(mm)		(ft-lbs)	(Nm)	R	L	W	H		R	L	W	H		
RSL1500	7/8	-	RPL1014	320	434	0.79	6.00	1.25	4.33	2.2	20,1	152,4	31,8	110,0	1,0	
	1 1/16	26	RPL1101	640	868	0.95	6.05	1.25	4.50	2.2	24,1	153,7	31,8	114,3	1,0	
	1 1/8	-	RPL1102	640	868	1.03	6.12	1.25	4.57	2.3	26,2	155,4	31,8	116,1	1,0	
	1 3/16	30	RPL1103	640	868	1.03	6.12	1.25	4.57	2.3	26,2	155,4	31,8	116,1	1,0	
	1 1/4	32	RPL1104	640	868	1.03	6.12	1.25	4.57	2.3	26,2	155,4	31,8	116,1	1,0	
	1 5/16	33	RPL1105	900	1220	1.15	6.24	1.25	4.69	2.4	29,2	158,5	31,8	119,1	1,1	
	1 3/8	35	RPL1106	900	1220	1.15	6.24	1.25	4.69	2.4	29,2	158,5	31,8	119,1	1,1	
	1 7/16	36	RPL1107	900	1220	1.15	6.24	1.25	4.69	2.4	29,2	158,5	31,8	119,1	1,1	
	1 1/2	38	RPL1108	1408	1909	1.31	6.41	1.25	4.86	2.7	33,3	162,8	31,8	123,4	1,2	
	1 9/16	-	RPL1109	1408	1909	1.31	6.41	1.25	4.86	2.7	33,3	162,8	31,8	123,4	1,2	
	1 5/8	41	RPL1110	1408	1909	1.31	6.41	1.25	4.86	2.7	33,3	162,8	31,8	123,4	1,2	
	1 11/16	-	RPL1111	1408	1909	1.40	6.49	1.25	4.94	2.7	35,6	164,8	31,8	125,5	1,2	
	1 3/4	-	RPL1112	1408	1909	1.40	6.49	1.25	4.94	2.7	35,6	164,8	31,8	125,5	1,2	
	1 13/16	46	RPL1113	1408	1909	1.40	6.49	1.25	4.94	2.7	35,6	164,8	31,8	125,5	1,2	
	1 7/8	-	RPL1114	1408	1909	1.48	6.58	1.25	5.03	2.7	37,6	167,1	31,8	127,8	1,2	
	1 15/16	-	RPL1115	1408	1909	1.48	6.58	1.25	5.03	2.7	37,6	167,1	31,8	127,8	1,2	
	2	50	RPL1200	1408	1909	1.48	6.58	1.25	5.03	2.7	37,6	167,1	31,8	127,8	1,2	
	2 1/16	-	RPL1201	1408	1909	1.58	6.68	1.25	5.13	2.7	40,1	169,7	31,8	130,3	1,2	
	2 1/8	-	RPL1202	1408	1909	1.58	6.68	1.25	5.13	2.7	40,1	169,7	31,8	130,3	1,2	
	2 3/16	55	RPL1203	1408	1909	1.58	6.68	1.25	5.13	2.7	40,1	169,7	31,8	130,3	1,2	
	2 1/4	-	RPL1204	1408	1909	1.70	6.79	1.25	5.24	2.8	43,2	172,5	31,8	133,1	1,3	
	2 5/16	-	RPL1205	1408	1909	1.70	6.79	1.25	5.24	2.8	43,2	172,5	31,8	133,1	1,3	
	2 3/8	60	RPL1206	1408	1909	1.70	6.79	1.25	5.24	2.8	43,2	172,5	31,8	133,1	1,3	
	RSL3000	1 5/16	33	RPL3105	900	1220	1.18	7.62	1.38	5.49	3.5	30,0	193,5	35,1	139,4	1,6
		1 3/8	35	RPL3106	900	1220	1.18	7.62	1.38	5.49	3.5	30,0	193,5	35,1	139,4	1,6
1 7/16		36	RPL3107	900	1220	1.18	7.62	1.38	5.49	3.5	30,0	193,5	35,1	139,4	1,6	
1 1/2		38	RPL3108	1200	1627	1.32	7.77	1.38	5.63	3.9	33,5	197,4	35,1	143,0	1,8	
1 9/16		-	RPL3109	1200	1627	1.32	7.77	1.38	5.63	3.9	33,5	197,4	35,1	143,0	1,8	
1 5/8		41	RPL3110	1200	1627	1.32	7.77	1.38	5.63	3.9	33,5	197,4	35,1	143,0	1,8	
1 11/16		-	RPL3111	1900	2576	1.47	7.87	1.38	5.78	4.0	37,3	199,9	35,1	146,8	1,8	
1 3/4		-	RPL3112	1900	2576	1.47	7.87	1.38	5.78	4.0	37,3	199,9	35,1	146,8	1,8	
1 13/16		46	RPL3113	1900	2576	1.47	7.87	1.38	5.78	4.0	37,3	199,9	35,1	146,8	1,8	
1 7/8		-	RPL3114	2600	3526	1.60	8.04	1.38	5.92	4.5	40,6	204,2	35,1	150,4	2,0	
1 15/16		-	RPL3115	2600	3526	1.60	8.04	1.38	5.92	4.5	40,6	204,2	35,1	150,4	2,0	
2		50	RPL3200	2600	3526	1.60	8.04	1.38	5.92	4.5	40,6	204,2	35,1	150,4	2,0	
2 1/16		-	RPL3201	3080	4176	1.76	8.16	1.38	6.08	4.7	44,7	207,3	35,1	154,4	2,1	
2 1/8		-	RPL3202	3080	4176	1.76	8.16	1.38	6.08	4.7	44,7	207,3	35,1	154,4	2,1	
2 3/16		55	RPL3203	3080	4176	1.76	8.16	1.38	6.08	4.7	44,7	207,3	35,1	154,4	2,1	
2 1/4		-	RPL3204	3080	4176	1.84	8.25	1.38	6.15	4.8	46,7	209,6	35,1	156,2	2,2	
2 5/16		-	RPL3205	3080	4176	1.84	8.25	1.38	6.15	4.8	46,7	209,6	35,1	156,2	2,2	
2 3/8		60	RPL3206	3080	4176	1.84	8.25	1.38	6.15	4.8	46,7	209,6	35,1	156,2	2,2	
2 7/16		62	RPL3207	3080	4176	1.95	8.14	1.38	6.26	4.6	49,5	206,8	35,1	159,0	2,1	
2 1/2		63	RPL3208	3080	4176	1.95	8.14	1.38	6.26	4.6	49,5	206,8	35,1	159,0	2,1	
2 9/16		65	RPL3209	3080	4176	1.95	8.14	1.38	6.26	4.6	49,5	206,8	35,1	159,0	2,1	
2 5/8		-	RPL3210	3080	4176	2.04	8.23	1.38	6.36	4.4	51,8	209,0	35,1	161,5	2,0	
2 11/16		-	RPL3211	3080	4176	2.04	8.23	1.38	6.36	4.4	51,8	209,0	35,1	161,5	2,0	
2 3/4		70	RPL3212	3080	4176	2.04	8.23	1.38	6.36	4.4	51,8	209,0	35,1	161,5	2,0	
2 13/16		-	RPL3213	3080	4176	2.16	8.34	1.38	6.54	4.7	54,9	211,8	35,1	166,1	2,1	
2 7/8	-	RPL3214	3080	4176	2.16	8.34	1.38	6.54	4.7	54,9	211,8	35,1	166,1	2,1		
2 15/16	75	RPL3215	3080	4176	2.16	8.34	1.38	6.54	4.7	54,9	211,8	35,1	166,1	2,1		

Hexagon Cassettes for RSL-Series



Enerpac's Bolting Integrity Software Solutions

play a key role in implementing and managing an Integrity Program for bolted connections. Our Bolting Software Suite includes **BoltUp** (free, online calculator providing reliable, repeatable bolt loads), **Informate** (bolt load calculation software for huge range of flanged joints and clamped connections), and **Integrity Data Management System/iDMS** (flexible data management and activity-planning system for use on assets featuring bolted connections).

Contact Enerpac for more information.

Page: 416



Slimline Hexagon Cassettes

For accessing narrow spaces RLP...SL Stepped-Width Hexagon Cassettes are available. Slimline cassettes use same drive unit as standard RLP-cassettes.

270

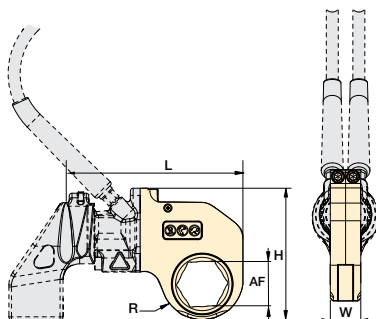

RSL Series



Hexagon Range:
7/8 - 6 1/8 inches

Hexagon Range:
26 - 155 mm

Maximum Operating Pressure:
10,000 psi

▼ SELECTION CHART

Drive Unit Model Number	Hexagon Size A/F		Hexagon Cassette Model Number	Maximum Torque Output		Dimensions (in)				Wt. (lbs)	Dimensions (mm)				Wt. (kg)
	(in)	(mm)		(ft-lbs)	(Nm)	R	L	W	H		R	L	W	H	
RSL5000	1 1/16	-	RLP5111	2600	3526	1.61	9.08	1.75	6.52	6.6	40,9	230,6	44,5	165,6	3,0
	1 3/4	-	RLP5112	2600	3526	1.61	9.08	1.75	6.52	6.6	40,9	230,6	44,5	165,6	3,0
	1 3/16	46	RLP5113	2600	3526	1.61	9.08	1.75	6.52	6.6	40,9	230,6	44,5	165,6	3,0
	1 7/8	-	RLP5114	2600	3526	1.61	9.08	1.75	6.52	6.6	40,9	230,6	44,5	165,6	3,0
	1 5/16	-	RLP5115	2600	3526	1.61	9.08	1.75	6.52	6.6	40,9	230,6	44,5	165,6	3,0
	2	50	RLP5200	2600	3526	1.61	9.08	1.75	6.52	6.6	40,9	230,6	44,5	165,6	3,0
	2 1/16	-	RLP5201	3500	4746	1.71	9.18	1.75	6.62	6.5	43,4	233,2	44,5	168,1	2,9
	2 1/8	-	RLP5202	3500	4746	1.71	9.18	1.75	6.62	6.5	43,4	233,2	44,5	168,1	2,9
	2 3/16	55	RLP5203	3500	4746	1.71	9.18	1.75	6.62	6.5	43,4	233,2	44,5	168,1	2,9
	2 1/4	-	RLP5204	4500	6102	1.87	9.34	1.75	6.78	7.0	47,5	237,2	44,5	172,2	3,2
	2 5/16	-	RLP5205	4500	6102	1.87	9.34	1.75	6.78	7.0	47,5	237,2	44,5	172,2	3,2
	2 3/8	60	RLP5206	4500	6102	1.87	9.34	1.75	6.78	7.0	47,5	237,2	44,5	172,2	3,2
	2 7/16	62	RLP5207	5303	7191	2.01	9.48	1.75	6.92	7.0	51,1	240,8	44,5	175,8	3,2
	2 1/2	63	RLP5208	5303	7191	2.01	9.48	1.75	6.92	7.0	51,1	240,8	44,5	175,8	3,2
	2 9/16	65	RLP5209	5303	7191	2.01	9.48	1.75	6.92	7.0	51,1	240,8	44,5	175,8	3,2
	2 5/8	-	RLP5210	5303	7191	2.16	9.63	1.75	7.07	7.5	54,9	244,6	44,5	179,6	3,4
	2 1 1/16	-	RLP5211	5303	7191	2.16	9.63	1.75	7.07	7.5	54,9	244,6	44,5	179,6	3,4
	2 3/4	70	RLP5212	5303	7191	2.16	9.63	1.75	7.07	7.5	54,9	244,6	44,5	179,6	3,4
	2 3 1/16	-	RLP5213	5303	7191	2.24	9.71	1.75	7.15	7.5	56,9	246,6	44,5	181,6	3,4
	2 7/8	-	RLP5214	5303	7191	2.24	9.71	1.75	7.15	7.5	56,9	246,6	44,5	181,6	3,4
2 5 1/16	75	RLP5215	5303	7191	2.24	9.71	1.75	7.15	7.5	56,9	246,6	44,5	181,6	3,4	
3	-	RLP5300	5303	7191	2.26	9.73	1.75	7.17	7.2	57,4	247,1	44,5	182,1	3,3	
3 1/16	-	RLP5301	5303	7191	2.26	9.73	1.75	7.17	7.2	57,4	247,1	44,5	182,1	3,3	
3 1/8	80	RLP5302	5303	7191	2.26	9.73	1.75	7.17	7.2	57,4	247,1	44,5	182,1	3,3	
RSL8000	2 3/8	60	RLP8206	4500	6102	1.87	9.53	2.25	7.00	8.9	47,5	242,1	57,2	177,8	4,0
	2 7/16	62	RLP8207	5800	7865	2.01	9.67	2.25	7.13	9.0	51,1	245,6	57,2	181,1	4,1
	2 1/2	63	RLP8208	5800	7865	2.01	9.67	2.25	7.13	9.0	51,1	245,6	57,2	181,1	4,1
	2 9/16	65	RLP8209	5800	7865	2.01	9.67	2.25	7.13	9.0	51,1	245,6	57,2	181,1	4,1
	2 5/8	-	RLP8210	7862	10.661	2.16	9.82	2.25	7.28	9.6	54,9	249,4	57,2	184,9	4,4
	2 1 1/16	-	RLP8211	7862	10.661	2.16	9.82	2.25	7.28	9.6	54,9	249,4	57,2	184,9	4,4
	2 3/4	70	RLP8212	7862	10.661	2.16	9.82	2.25	7.28	9.6	54,9	249,4	57,2	184,9	4,4
	2 3 1/16	-	RLP8213	7862	10.661	2.24	9.90	2.25	7.38	9.6	56,9	251,5	57,2	187,5	4,4
	2 7/8	-	RLP8214	7862	10.661	2.24	9.90	2.25	7.38	9.6	56,9	251,5	57,2	187,5	4,4
	2 5 1/16	75	RLP8215	7862	10.661	2.24	9.90	2.25	7.38	9.6	56,9	251,5	57,2	187,5	4,4
	3	-	RLP8300	7862	10.661	2.26	9.92	2.25	7.39	9.3	57,4	252,0	57,2	187,7	4,2
	3 1/16	-	RLP8301	7862	10.661	2.26	9.92	2.25	7.39	9.3	57,4	252,0	57,2	187,7	4,2
3 1/8	80	RLP8302	7862	10.661	2.26	9.92	2.25	7.39	9.3	57,4	252,0	57,2	187,7	4,2	

RSL Series

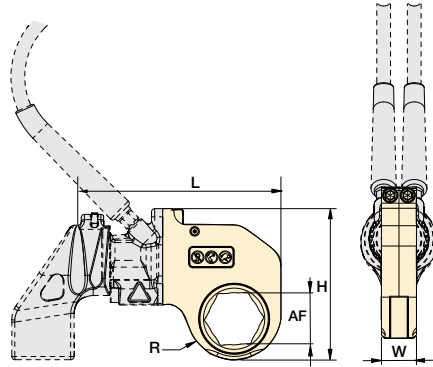

Hexagon Range:

7/8 - 6 1/8 inches

Hexagon Range:

26 - 155 mm

Maximum Operating Pressure:

10,000 psi

▼ SELECTION CHART

Drive Unit Model Number	Hexagon Size A/F		Hexagon Cassette Model Number	Maximum Torque Output		Dimensions (in)				Wt. (lbs)	Dimensions (mm)				Wt. (kg)
	(in)	(mm)		(ft-lbs)	(Nm)	R	L	W	H		R	L	W	H	
RSL11000	2 7/16	62	RLP11207	5800	7865	1.98	10.00	2.50	8.03	14.2	50,3	254,0	63,5	204,0	6,4
	2 1/2	-	RLP11208	5800	7865	1.98	10.00	2.50	8.03	14.2	50,3	254,0	63,5	204,0	6,4
	2 9/16	65	RLP11209	5800	7865	1.98	10.00	2.50	8.03	14.2	50,3	254,0	63,5	204,0	6,4
	2 5/8	-	RLP11210	7300	9899	2.19	11.20	2.50	8.23	14.8	55,6	284,5	63,5	209,0	6,7
	2 11/16	-	RLP11211	7300	9899	2.19	11.20	2.50	8.23	14.8	55,6	284,5	63,5	209,0	6,7
	2 3/4	70	RLP11212	7300	9899	2.19	11.20	2.50	8.23	14.8	55,6	284,5	63,5	209,0	6,7
	2 13/16	-	RLP11213	9000	12.204	2.29	11.31	2.50	8.34	14.8	58,2	287,3	63,5	211,8	6,7
	2 7/8	-	RLP11214	9000	12.204	2.29	11.31	2.50	8.34	14.8	58,2	287,3	63,5	211,8	6,7
	2 15/16	75	RLP11215	9000	12.204	2.29	11.31	2.50	8.34	14.8	58,2	287,3	63,5	211,8	6,7
	3	-	RLP11300	11,154	15.125	2.43	11.44	2.50	8.47	15.2	61,7	290,6	63,5	215,1	6,9
	3 1/16	-	RLP11301	11,154	15.125	2.43	11.44	2.50	8.47	15.2	61,7	290,6	63,5	215,1	6,9
	3 1/8	80	RLP11302	11,154	15.125	2.43	11.44	2.50	8.47	15.2	61,7	290,6	63,5	215,1	6,9
	3 3/16	-	RLP11303	11,154	15.125	2.60	11.71	2.50	8.64	16.6	66,0	297,4	63,5	219,5	7,5
	-	85	RLP11085M	11,154	15.125	2.60	11.71	2.50	8.64	16.6	66,0	297,4	63,5	219,5	7,5
	3 1/4	-	RLP11304	11,154	15.125	2.60	11.71	2.50	8.64	16.6	66,0	297,4	63,5	219,5	7,5
	3 5/16	-	RLP11305	11,154	15.125	2.60	11.71	2.50	8.64	16.6	66,0	297,4	63,5	219,5	7,5
	3 3/8	-	RLP11306	11,154	15.125	2.60	11.71	2.50	8.64	16.6	66,0	297,4	63,5	219,5	7,5
	3 7/16	-	RLP11307	11,154	15.125	2.60	11.71	2.50	8.64	16.6	66,0	297,4	63,5	219,5	7,5
	3 1/2	-	RLP11308	11,154	15.125	2.60	11.71	2.50	8.64	16.6	66,0	297,4	63,5	219,5	7,5
	-	90	RLP11090M	11,154	15.125	2.88	11.89	2.50	8.92	17.2	73,2	302,0	63,5	226,6	7,8
	3 9/16	-	RLP11309	11,154	15.125	2.88	11.89	2.50	8.92	17.2	73,2	302,0	63,5	226,6	7,8
	3 5/8	-	RLP11310	11,154	15.125	2.88	11.89	2.50	8.92	17.2	73,2	302,0	63,5	226,6	7,8
	3 11/16	-	RLP11311	11,154	15.125	2.88	11.89	2.50	8.92	17.2	73,2	302,0	63,5	226,6	7,8
	3 3/4	95	RLP11312	11,154	15.125	2.88	11.89	2.50	8.92	17.2	73,2	302,0	63,5	226,6	7,8
	3 13/16	-	RLP11313	11,154	15.125	2.88	11.89	2.50	8.92	17.2	73,2	302,0	63,5	226,6	7,8
	3 7/8	-	RLP11314	11,154	15.125	2.88	11.89	2.50	8.92	17.2	73,2	302,0	63,5	226,6	7,8
	3 15/16	100	RLP11315	11,154	15.125	2.98	12.00	2.50	9.03	16.4	75,7	304,8	63,5	229,4	7,4
	4	-	RLP11400	11,154	15.125	2.98	12.00	2.50	9.03	16.4	75,7	304,8	63,5	229,4	7,4
	4 1/16	-	RLP11401	11,154	15.125	2.98	12.00	2.50	9.03	16.4	75,7	304,8	63,5	229,4	7,4
	4 1/8	105	RLP11402	11,154	15.125	2.98	12.00	2.50	9.03	16.4	75,7	304,8	63,5	229,4	7,4
	4 1/4	-	RLP11404	11,154	15.125	2.98	12.00	2.50	9.03	16.4	75,7	304,8	63,5	229,4	7,4
	4 5/16	110	RLP11405	11,154	15.125	3.25	12.27	2.50	9.30	17.6	82,6	311,7	63,5	236,2	8,0
	4 1/2	-	RLP11408	11,154	15.125	3.25	12.27	2.50	9.30	17.6	82,6	311,7	63,5	236,2	8,0
4 5/8	-	RLP11410	11,154	15.125	3.25	12.27	2.50	9.30	17.6	82,6	311,7	63,5	236,2	8,0	

Hexagon Cassettes for RSL-Series



Enerpac's Bolting Integrity Software Solutions

play a key role in implementing and managing an Integrity Program for bolted connections. Our Bolting Software Suite includes **BoltUp** (free, online calculator providing reliable, repeatable bolt loads), **Informate** (bolt load calculation software for huge range of flanged joints and clamped connections), and **Integrity Data Management System/iDMS** (flexible data management and activity-planning system for use on assets featuring bolted connections).

Contact Enerpac for more information.

Page: 416

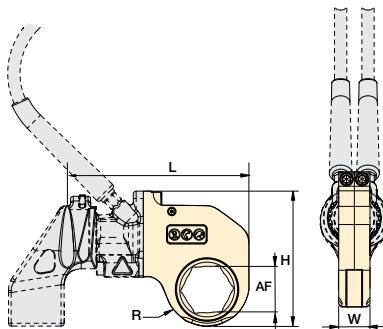

RSL Series



Hexagon Range:
7/8 - 6 1/8 inches

Hexagon Range:
26 - 155 mm

Maximum Operating Pressure:
10,000 psi

▼ SELECTION CHART

Drive Unit Model Number	Hexagon Size A/F		Hexagon Cassette Model Number	Maximum Torque Output		Dimensions (in)				Wt. (lbs)	Dimensions (mm)				Wt. (kg)
	(in)	(mm)		(ft-lbs)	(Nm)	R	L	W	H		R	L	W	H	
RSL19000	2 ¹⁵ / ₁₆	75	RLP19215	11,000	14.916	2.45	12.72	2.75	9.44	21.5	62,2	323,1	69,9	239,8	9,8
	3	-	RLP19300	11,000	14.916	2.45	12.72	2.75	9.44	21.5	62,2	323,1	69,9	239,8	9,8
	3 ¹ / ₁₆	-	RLP19301	11,000	14.916	2.45	12.72	2.75	9.44	21.5	62,2	323,1	69,9	239,8	9,8
	3 ¹ / ₈	80	RLP19302	11,000	14.916	2.45	12.72	2.75	9.44	21.5	62,2	323,1	69,9	239,8	9,8
	3 ³ / ₁₆	-	RLP19303	16,000	21.696	2.77	13.04	2.75	9.76	22.6	70,4	331,2	69,9	247,9	10,3
	-	85	RLP19085M	16,000	21.696	2.77	13.04	2.75	9.76	22.6	70,4	331,2	69,9	247,9	10,3
	3 ¹ / ₄	-	RLP19304	16,000	21.696	2.77	13.04	2.75	9.76	22.6	70,4	331,2	69,9	247,9	10,3
	3 ⁵ / ₁₆	-	RLP19305	16,000	21.696	2.77	13.04	2.75	9.76	22.6	70,4	331,2	69,9	247,9	10,3
	3 ³ / ₈	-	RLP19306	16,000	21.696	2.77	13.04	2.75	9.76	22.6	70,4	331,2	69,9	247,9	10,3
	3 ⁷ / ₁₆	-	RLP19307	16,000	21.696	2.77	13.04	2.75	9.76	22.6	70,4	331,2	69,9	247,9	10,3
	3 ¹ / ₂	-	RLP19308	16,000	21.696	2.77	13.04	2.75	9.76	22.6	70,4	331,2	69,9	247,9	10,3
	-	90	RLP19090M	18,843	25.551	2.95	13.22	2.75	9.94	23.8	74,9	335,8	69,9	252,5	10,8
	3 ⁹ / ₁₆	-	RLP19309	18,843	25.551	2.95	13.22	2.75	9.94	23.8	74,9	335,8	69,9	252,5	10,8
	3 ⁵ / ₈	-	RLP19310	18,843	25.551	2.95	13.22	2.75	9.94	23.8	74,9	335,8	69,9	252,5	10,8
	3 ¹ / ₁₆	-	RLP19311	18,843	25.551	2.95	13.22	2.75	9.94	23.8	74,9	335,8	69,9	252,5	10,8
	3 ³ / ₄	95	RLP19312	18,843	25.551	2.95	13.22	2.75	9.94	23.8	74,9	335,8	69,9	252,5	10,8
	3 ¹³ / ₁₆	-	RLP19313	18,843	25.551	2.95	13.22	2.75	9.94	23.8	74,9	335,8	69,9	252,5	10,8
	3 ⁷ / ₈	-	RLP19314	18,843	25.551	2.95	13.22	2.75	9.94	23.8	74,9	335,8	69,9	252,5	10,8
	3 ¹⁵ / ₁₆	100	RLP19315	18,843	25.551	3.30	13.57	2.75	10.28	25.3	83,8	344,7	69,9	261,1	11,5
	4	-	RLP19400	18,843	25.551	3.30	13.57	2.75	10.28	25.3	83,8	344,7	69,9	261,1	11,5
	4 ¹ / ₁₆	-	RLP19401	18,843	25.551	3.30	13.57	2.75	10.28	25.3	83,8	344,7	69,9	261,1	11,5
	4 ¹ / ₈	105	RLP19402	18,843	25.551	3.30	13.57	2.75	10.28	25.3	83,8	344,7	69,9	261,1	11,5
	4 ³ / ₁₆	-	RLP19403	18,843	25.551	3.30	13.57	2.75	10.28	25.3	83,8	344,7	69,9	261,1	11,5
	4 ¹ / ₄	-	RLP19404	18,843	25.551	3.30	13.57	2.75	10.28	25.3	83,8	344,7	69,9	261,1	11,5
	4 ⁵ / ₁₆	110	RLP19405	18,843	25.551	3.44	13.71	2.75	10.43	25.6	87,4	348,2	69,9	264,9	11,6
	4 ³ / ₈	-	RLP19406	18,843	25.551	3.44	13.71	2.75	10.43	25.6	87,4	348,2	69,9	264,9	11,6
	4 ⁷ / ₁₆	-	RLP19407	18,843	25.551	3.44	13.71	2.75	10.43	25.6	87,4	348,2	69,9	264,9	11,6
	4 ¹ / ₂	-	RLP19408	18,843	25.551	3.44	13.71	2.75	10.43	25.6	87,4	348,2	69,9	264,9	11,6
	-	115	RLP19115M	18,843	25.551	3.44	13.71	2.75	10.43	25.6	87,4	348,2	69,9	264,9	11,6
	4 ⁹ / ₁₆	-	RLP19409	18,843	25.551	3.44	13.71	2.75	10.43	25.6	87,4	348,2	69,9	264,9	11,6
4 ⁵ / ₈	-	RLP19410	18,843	25.551	3.44	13.71	2.75	10.43	25.6	87,4	348,2	69,9	264,9	11,6	

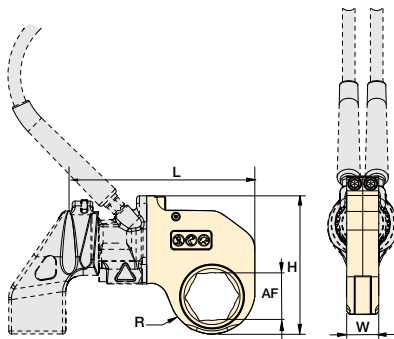

Hexagon Range:
7/8 - 6 1/8 inches

Hexagon Range:
26 - 155 mm

Maximum Operating Pressure:
10,000 psi

**RSL
Series**



▼ SELECTION CHART

Drive Unit Model Number	Hexagon Size A/F		Hexagon Cassette Model Number	Maximum Torque Output		Dimensions (in)				Wt. (lbs)	Dimensions (mm)				Wt. (kg)
	(in)	(mm)		(ft-lbs)	(Nm)	R	L	W	H		R	L	W	H	
RSL28000	3 1/8	80	RLP28302	16,000	21.696	2.56	14.36	3.00	10.54	27.6	65,0	364,7	76,2	267,7	12,5
	3 3/16	-	RLP28303	16,000	21.696	2.56	14.36	3.00	10.54	27.6	65,0	364,7	76,2	267,7	12,5
	-	85	RLP28085M	16,000	21.696	2.56	14.36	3.00	10.54	27.6	65,0	364,7	76,2	267,7	12,5
	3 1/4	-	RLP28304	16,000	21.696	2.56	14.36	3.00	10.54	27.6	65,0	364,7	76,2	267,7	12,5
	3 5/16	-	RLP28305	16,000	21.696	2.56	14.36	3.00	10.54	27.6	65,0	364,7	76,2	267,7	12,5
	3 3/8	-	RLP28306	16,000	21.696	2.56	14.36	3.00	10.54	27.6	65,0	364,7	76,2	267,7	12,5
	3 7/16	-	RLP28307	16,000	21.696	2.56	14.36	3.00	10.54	27.6	65,0	364,7	76,2	267,7	12,5
	3 1/2	-	RLP28308	16,000	21.696	2.56	14.36	3.00	10.54	27.6	65,0	364,7	76,2	267,7	12,5
	-	90	RLP28090M	22,000	29.832	2.92	14.36	3.00	10.77	28.8	74,2	364,7	76,2	273,6	13,1
	3 9/16	-	RLP28309	22,000	29.832	2.92	14.36	3.00	10.77	28.8	74,2	364,7	76,2	273,6	13,1
	3 5/8	-	RLP28310	22,000	29.832	2.92	14.36	3.00	10.77	28.8	74,2	364,7	76,2	273,6	13,1
	3 11/16	-	RLP28311	22,000	29.832	2.92	14.36	3.00	10.77	28.8	74,2	364,7	76,2	273,6	13,1
	3 3/4	95	RLP28312	22,000	29.832	2.92	14.36	3.00	10.77	28.8	74,2	364,7	76,2	273,6	13,1
	3 13/16	-	RLP28313	22,000	29.832	2.92	14.36	3.00	10.77	28.8	74,2	364,7	76,2	273,6	13,1
	3 7/8	-	RLP28314	22,000	29.832	2.92	14.36	3.00	10.77	28.8	74,2	364,7	76,2	273,6	13,1
	3 15/16	100	RLP28315	28,002	37.971	3.29	14.47	3.00	11.14	31.7	83,6	367,5	76,2	283,0	14,4
	4	-	RLP28400	28,002	37.971	3.29	14.47	3.00	11.14	31.7	83,6	367,5	76,2	283,0	14,4
	4 1/16	-	RLP28401	28,002	37.971	3.29	14.47	3.00	11.14	31.7	83,6	367,5	76,2	283,0	14,4
	4 1/8	105	RLP28402	28,002	37.971	3.29	14.47	3.00	11.14	31.7	83,6	367,5	76,2	283,0	14,4
	4 3/16	-	RLP28403	28,002	37.971	3.29	14.47	3.00	11.14	31.7	83,6	367,5	76,2	283,0	14,4
	4 1/4	-	RLP28404	28,002	37.971	3.29	14.47	3.00	11.14	31.7	83,6	367,5	76,2	283,0	14,4
	4 5/16	110	RLP28405	28,002	37.971	3.43	14.61	3.00	11.28	31.5	87,1	371,1	76,2	286,5	14,3
	4 3/8	-	RLP28406	28,002	37.971	3.43	14.61	3.00	11.28	31.5	87,1	371,1	76,2	286,5	14,3
	4 7/16	-	RLP28407	28,002	37.971	3.43	14.61	3.00	11.28	31.5	87,1	371,1	76,2	286,5	14,3
	4 1/2	-	RLP28408	28,002	37.971	3.43	14.61	3.00	11.28	31.5	87,1	371,1	76,2	286,5	14,3
	-	115	RLP28115M	28,002	37.971	3.43	14.61	3.00	11.28	31.5	87,1	371,1	76,2	286,5	14,3
	4 9/16	-	RLP28409	28,002	37.971	3.43	14.61	3.00	11.28	31.5	87,1	371,1	76,2	286,5	14,3
	4 5/8	-	RLP28410	28,002	37.971	3.43	14.61	3.00	11.28	31.5	87,1	371,1	76,2	286,5	14,3
	4 3/4	120	RLP28412	28,002	37.971	3.65	14.83	3.00	11.50	33.5	92,7	376,7	76,2	292,1	15,2
	-	123	RLP28123M	28,002	37.971	3.65	14.83	3.00	11.50	33.5	92,7	376,7	76,2	292,1	15,2
	4 7/8	-	RLP28414	28,002	37.971	3.65	14.83	3.00	11.50	33.5	92,7	376,7	76,2	292,1	15,2
	5	-	RLP28500	28,002	37.971	3.65	14.83	3.00	11.50	33.5	92,7	376,7	76,2	292,1	15,2
	5 1/8	130	RLP28502	28,002	37.971	3.79	14.97	3.00	11.64	33.2	96,3	380,2	76,2	295,7	15,1
	5 3/16	-	RLP28503	28,002	37.971	3.79	14.97	3.00	11.64	33.2	96,3	380,2	76,2	295,7	15,1
	5 1/4	-	RLP28504	28,002	37.971	3.79	14.97	3.00	11.64	33.2	96,3	380,2	76,2	295,7	15,1
	5 5/8	135	RLP28506	28,002	37.971	3.79	14.97	3.00	11.64	33.2	96,3	380,2	76,2	295,7	15,1
	5 1/2	140	RLP28508	28,002	37.971	4.05	15.23	3.00	11.90	33.5	102,9	386,8	76,2	302,3	15,2
	5 9/16	-	RLP28509	28,002	37.971	4.05	15.23	3.00	11.90	33.5	102,9	386,8	76,2	302,3	15,2
	5 3/8	-	RLP28510	28,002	37.971	4.05	15.23	3.00	11.90	33.5	102,9	386,8	76,2	302,3	15,2
	5 3/4	145	RLP28512	28,002	37.971	4.05	15.23	3.00	11.90	33.5	102,9	386,8	76,2	302,3	15,2
5 7/8	150	RLP28514	28,002	37.971	4.22	15.48	3.00	12.15	34.5	107,2	393,2	76,2	308,6	15,6	
6	-	RLP28600	28,002	37.971	4.22	15.48	3.00	12.15	34.5	107,2	393,2	76,2	308,6	15,6	
6 1/8	155	RLP28602	28,002	37.971	4.22	15.48	3.00	12.15	34.5	107,2	393,2	76,2	308,6	15,6	

▼ TWMP503



TWMP503, Torque Wrench Moly Paste

- Enerpac 503 Moly Paste reduces friction on threaded fasteners – bolts, nuts and studs
- The low and uniform friction coefficient of 0.06 (torque coefficient, K, of 0.11) creates reliable assembly conditions
- This lubricant stays in place through heat, load and vibration to ensure trouble-free disassembly from -20° F to 750° F (-29° C to 400° C)
- 4 lbs. (1,8 kg) container

for
RSL Series



ERA-Series, Extended Reaction Arms

For Torque Wrench Model No.	Model Number	Dimensions (in)					(lbs)
		A	B	C	D	E	
RSL1500	ERA15114	3.42	5.71	7.68	1.14	1.42	1.98
	ERA15228	4.45	7.13	9.06	1.14	1.42	3.97
	ERA15342	5.47	8.90	10.87	1.14	1.42	5.95
	ERA15456	6.46	9.29	11.26	1.14	1.42	7.94
	ERA15570	7.44	11.30	13.27	1.14	1.42	9.92
RSL3000	ERA30114	4.13	7.68	10.12	1.34	1.61	5.95
	ERA30228	5.16	9.09	11.54	1.34	1.61	7.94
	ERA30342	6.14	10.47	12.91	1.34	1.61	9.92
	ERA30456	7.13	11.89	14.66	1.34	1.61	11.90
RSL5000	ERA50114	5.16	8.19	11.18	1.73	1.89	9.04
	ERA50228	6.14	9.57	12.60	1.73	1.89	11.02
	ERA50342	7.13	10.98	13.98	1.73	1.89	13.01
	ERA50456	8.15	12.37	15.39	1.73	1.89	15.00
RSL11000	ERA110114	4.92	8.62	11.65	2.01	2.32	13.89
	ERA110228	5.91	10.04	13.06	2.01	2.32	16.09
	ERA110342	6.93	11.46	14.45	2.01	2.32	18.08
	ERA110456	7.91	12.83	15.83	2.01	2.32	20.06
RSL28000	ERA280228	6.73	13.19	16.18	2.24	3.50	24.91
	ERA280342	7.76	14.57	17.60	2.24	3.50	30.00

NOTE: Extended Reaction Arms for RSL8000 and RSL19000 are available on request.

- Only to be used on RSL-drive units with RSQ-square drive wrenches
- Used in place of standard reaction arm
- Lightweight interchangeable design
- Full torque rated

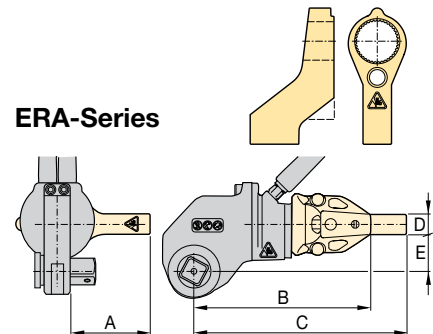

ERT-Series, Extended Reaction Tubes

For Torque Wrench Model No.	Model Number	Dimensions (in)			Wt. (lbs)
		A	B	Ø C	
RSL1500	ERT152	6.18	2.01	2.24	1.98
	ERT156	10.20	5.98	2.24	3.53
	ERT159	13.19	9.02	2.24	5.51
	ERT1512	16.18	12.01	2.24	7.50
	ERT1524	28.19	24.02	2.24	14.78
RSL3000	ERT3012	16.89	12.01	2.76	6.61
	ERT3024	28.90	24.02	2.76	13.01
RSL5000	ERT5012	17.76	12.01	3.50	12.35
	ERT5024	29.76	24.02	3.50	24.91
RSL11000	ERT1106	12.99	5.98	3.74	4.63
	ERT11012	19.02	12.01	3.74	9.04
	ERT11018	25.00	17.99	3.74	13.45
	ERT11024	30.98	24.02	3.74	18.52
RSL19000	ERT19024	31.50	24.02	5	36.82
RSL28000	ERT2806	13.82	5.98	5	7.94
	ERT28012	19.80	12.01	5	16.09
	ERT28018	25.79	17.99	5	24.03
	ERT28024	31.81	24.02	5	36.60

NOTE: Extended Reaction Tubes for RSL8000 are available on request.

- Only to be used on RSL-drive units with RLP-hexagon cassettes
- Used in place of standard reaction arm
- One-piece steel design, durable and simple
- Increases tool fit in restricted access areas
- Full torque rated

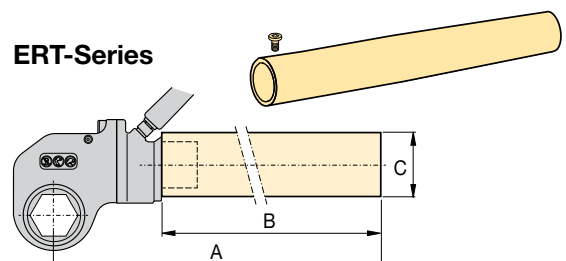

▼ Shown: RSL drive unit with interchangeable RLP—SL slimline cassette



Setting New Standards in Simplicity, Versatility and Accuracy



Torque Wrench Pumps

Visit enerpac.com for system matched air and electric torque wrench pumps that are ideal for use with hydraulic torque wrenches.

Page: 291



Options and Accessories

Optional extended reaction arms and tubes are common accessories available for maximum versatility. Please contact your Enerpac representative to help you select the optimum solution for your application.

Page: 269



Back-Up Spanner

To be used to stop back nut from turning during make up or break out. Two hex sizes in one tool.

Hexagon Sizes (A/F)		Back-Up Spanner Model Number
(in)	(mm)	
1 ¹ / ₁₆ - 1 ¹ / ₄	27 - 32	BUS01
1 ⁷ / ₁₆ - 1 ⁵ / ₈	36 - 41	BUS02
1 ¹³ / ₁₆ - 2	46 - 50	BUS03
2 ³ / ₁₆ - 2 ³ / ₈	55 - 60	BUS04
2 ⁹ / ₁₆ - 2 ³ / ₄	65 - 70	BUS05
2 ¹⁵ / ₁₆ - 3 ¹ / ₈	75 - 80	BUS06
3 ¹ / ₂ - 3 ⁷ / ₈	–	BUS07
4 ¹ / ₄ - 4 ⁵ / ₈	–	BUS08
–	85 - 90	BUS09
3 ³ / ₄ - 3 ¹⁵ / ₁₆	95 - 100	BUS10
4 ¹ / ₈ - 4 ¹⁵ / ₁₆	105 - 110	BUS11
–	115 - 120	BUS12

Page: 245

Simplicity

- Minimum nose radius for trouble-free tool fit which makes it uniquely equipped to access tight spaces, such as Blowout Preventers (BOPs)
- Simple robust alloy steel design with three moving parts for reduced maintenance
- Proven to perform even in the harshest environments
- Reaction arm has a simple dial lock for rapid change
- Designed to give optimum strength-to-weight and torque- to-weight ratios

Versatility

- Interchangeable cassette design
- Drive unit / hexagon cassette combination for limited height in line solutions
- Wide range of hexagon sizes available for all applications

Accuracy

- Constant torque output provides accuracy of +/-3% across full stroke

Ease of Use

- Few moving parts are easily accessible for quick field maintenance
- Innovative design that completely encloses all moving parts and minimizes pinch points

Slimline Stepped-Width Hexagon Cassettes



Slimline Stepped-Width Hexagon Cassettes

Accessing narrow spaces, typically found on BOP stacks, normally requires significantly reducing the width of the torque wrench. For the tool operator, this has always meant vastly reduced tool durability, and/or reduced torque output.

By using the highest-grade materials and perfecting the geometry, the RSL Slimline cassettes are able to provide greater torque, get into tighter spaces, and vastly outperform the competition in product durability.

RSL Series



Hexagon Range:

1 1/4 - 3 3/16 inches

Hexagon Range:

32 - 80 mm

Maximum Operating Pressure:

10,000 psi

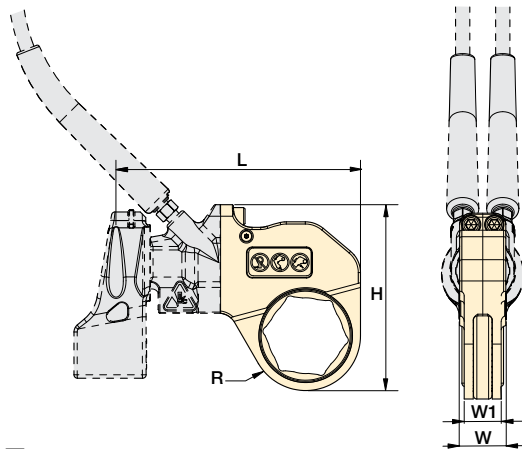

Select the Right Torque

Choose your Enerpac Torque Wrench using the untightening rule of thumb: Loosening torque equals about 250% of tightening torque.

▼ SELECTION CHART

Drive Unit Model Number	Hexagon Size A/F		Hexagon Cassette Model Number	Maximum Torque Output		Dimensions (in)					Wt. (lbs)	Dimensions (mm)					Wt. (kg)
	(in)	(mm)		(ft-lbs)	(Nm)	R	L	W	W1	H		R	L	W	W1	H	
RSL1500	1 1/4	32	RLP1104SL	375	509	1.03	6.12	1.25	1.00	4.57	2.2	26,2	155,4	31,8	25,4	116,1	1,0
	1 7/16	36	RLP1107SL	658	892	1.15	6.24	1.25	1.00	4.69	2.3	29,2	158,5	31,8	25,4	119,1	1,0
	1 5/8	41	RLP1110SL	831	1127	1.31	6.41	1.25	1.00	4.86	2.7	33,3	162,8	31,8	25,4	123,4	1,2
	1 13/16	46	RLP1113SL	831	1127	1.40	6.49	1.25	1.00	4.94	2.7	35,6	164,8	31,8	25,4	125,5	1,2
	2	50	RLP1200SL	831	1127	1.48	6.58	1.25	1.00	5.03	2.7	37,6	167,1	31,8	25,4	127,8	1,2
RSL3000	2	50	RLP3200SL	1354	1836	1.60	8.04	1.38	1.13	5.92	4.5	40,6	204,2	35,1	28,7	150,4	2,0
	2 3/16	55	RLP3203SL	1604	2175	1.76	8.16	1.38	1.13	6.08	4.7	44,7	207,3	35,1	28,7	154,4	2,1
	2 3/8	60	RLP3206SL	1604	2175	1.84	8.25	1.38	1.13	6.15	4.8	46,7	209,6	35,1	28,7	156,2	2,2
	2 9/16	65	RLP3209SL	1604	2175	1.95	8.14	1.38	1.13	6.26	4.6	49,5	206,8	35,1	28,7	159,0	2,1
	2 3/4	70	RLP3212SL	1604	2175	2.04	8.23	1.38	1.13	6.36	4.4	51,8	209,0	35,1	28,7	161,5	2,0
RSL5000	2 15/16	75	RLP3215SL	1604	2175	2.16	8.34	1.38	1.13	6.54	4.7	54,9	211,8	35,1	28,7	166,1	2,1
	2 3/4	70	RLP5212SL	4173	5659	2.16	9.63	1.75	1.62	7.07	7.5	54,9	244,6	44,5	41,1	179,6	3,4
	3 1/8	80	RLP5302SL	4173	5659	2.26	9.73	1.75	1.62	7.17	7.2	57,4	247,1	44,5	41,1	182,1	3,3
RSL8000	2 3/16	55	RLP8203SL	2487	3372	1.71	9.53	2.25	2.00	6.84	8.5	43,4	242,1	57,2	50,8	173,7	3,9
	2 3/8	60	RLP8206SL	3198	4336	1.87	9.67	2.25	2.00	7.00	8.9	47,5	245,6	57,2	50,8	177,8	4,0
	2 9/16	65	RLP8209SL	4122	5589	2.01	9.67	2.25	2.00	7.13	9.0	51,1	245,6	57,2	50,8	181,1	4,1
	2 3/4	70	RLP8212SL	5587	7576	2.16	9.82	2.25	2.00	7.28	9.6	54,9	249,4	57,2	50,8	184,9	4,4
	2 15/16	75	RLP8215SL	5587	7576	2.24	9.90	2.25	2.00	7.36	9.6	56,9	251,5	57,2	50,8	186,9	4,4
	3 1/8	80	RLP8302SL	5587	7576	2.26	9.92	2.25	2.00	7.39	9.3	57,4	252,0	57,2	50,8	187,7	4,2
3 3/16	-	RLP8303SL	4740	6427	2.26	9.92	2.25	2.00	7.39	9.3	57,4	252,0	57,2	50,8	187,7	4,2	

▼ RSL drive unit with interchangeable RSQ square drive cassette



Setting New Standards in Safety, Simplicity and Performance



Torque Wrench Options and Accessories

Optional accessories are available for maximum versatility. Please contact your Enerpac representative to help you select the optimum solution for your application.



Select the Right Torque

Choose your Enerpac Torque Wrench using the untightening rule of thumb: Loosening torque equals about 250% of tightening torque.

Page: 412



BSH-Series Sockets

Heavy-Duty Impact Sockets for power driven torquing equipment.

Page: 244



Back-Up Spanners

Hands free tool to be used to stop back nut from turning during make up or break out.

Page: 245



Torque Wrench Hoses

Series hoses with RSL-Series torque wrenches to ensure the integrity of your hydraulic system.

6 feet long, 2 hoses	THQ702T
19.5 feet long, 2 hoses	THQ706T
39 feet long, 2 hoses	THQ712T

Safety and Performance

- Innovative design that completely encloses all moving parts and minimizes pinch points
- 30–35° of operating stroke provides added productivity while avoiding “tool lock on” which is common with some torque wrench designs

Simplicity

- Simple robust design with just three moving parts for reduced maintenance
- Robust handles are available which mount on both sides and the tops of cassettes to allow for extra maneuverability
- Pull-type square drive release for quickly reversing the square drive for tightening or loosening

Versatility

- Square Drive Sets available with interchangeable Hexagon Cassettes
- Power head / square drive combination for flexible use with standard impact quality sockets
- Reaction arm has a simple dial lock for rapid change

Accuracy

- Constant torque output provides accuracy of +/-3% across full stroke

RSL-Series, Square Drive Torque Wrenches

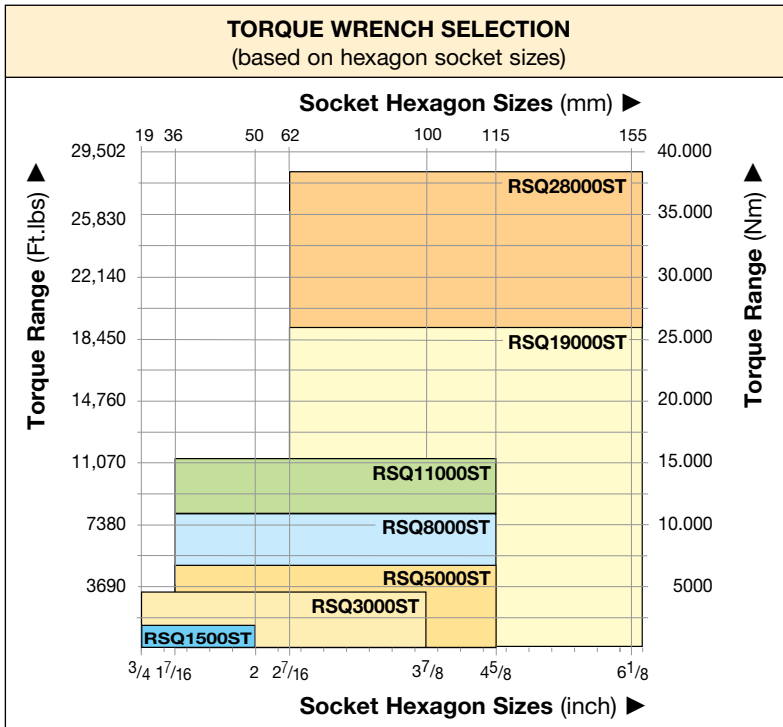

See page 244 for BSH-Sockets.

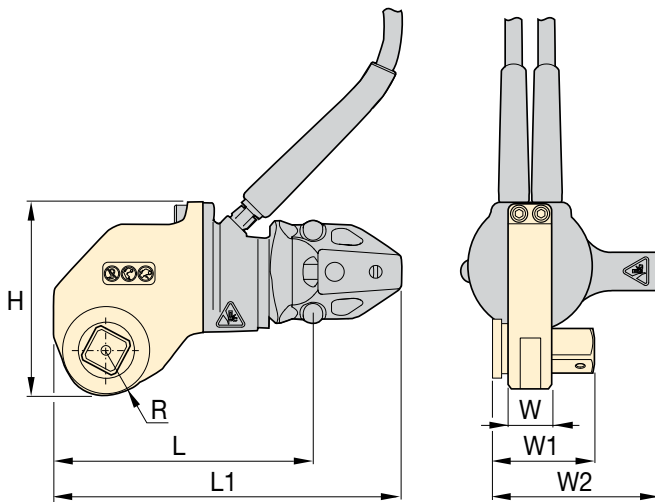

SELECTION CHART

Maximum Torque Output		Square Drive Size (in)	Square Drive Head Model Numbers ¹⁾	Square Drive Torque Wrench Set Model Numbers ²⁾	Dimensions (in)							Weight (lbs)		
(ft-lbs)	(Nm)				W	W1	W2	H	L	L1	R	Drive Unit (no reaction arm)	Reaction Arm	Square Drive Head
1408	1909	3/4	RSQ1500	RSQ1500ST	1.25	2.30	3.98	4.48	6.29	7.45	0.94	3.4	1.0	2.8
3080	4176	1	RSQ3000	RSQ3000ST	1.50	2.88	4.89	5.57	7.67	10.30	1.25	5.6	2.2	5.2
5303	7190	1 1/2	RSQ5000	RSQ5000ST	1.75	3.71	6.31	6.42	9.27	11.67	1.52	8.9	4.0	9.1
7862	10659	1 1/2	RSQ8000	RSQ8000ST	2.40	4.14	6.30	6.65	9.47	11.78	1.52	10.6	4.3	11.6
11154	15123	1 1/2	RSQ11000	RSQ11000ST	2.50	4.63	6.70	7.93	11.20	12.40	1.88	11.6	6.6	18.4
18843	25547	2 1/2	RSQ19000	RSQ19000ST	3.25	6.38	10.42	9.48	13.46	18.97	2.50	20.0	15.7	28.9
28002	37965	2 1/2	RSQ28000	RSQ28000ST	3.50	6.54	8.93	10.35	14.09	21.07	2.50	22.0	11.1	39.3

¹⁾ When ordering an RSQ Square Drive Head the RSL Drive Unit must be ordered separately.x

²⁾ An RSQ...ST Torque Wrench Set includes a RSQ Square Drive Head, RSL Drive Unit with short Whip Hoses, and Reaction Arm

RSL Series



Maximum Torque Output:

1408 - 28,002 ft.lbs

Maximum Torque Output:

1909 - 37,965 Nm

Square Drive Range:

3/4 - 2 1/2 inches

Maximum Operating Pressure:

10,000 psi



Safe T™ Torque Lock

The Safe T™ Torque Lock is suitable for all bolted applications from 140 ft-lbs to 11,175 ft-lbs. using a heavy-duty impact socket.

The patented mechanical locking system creates a hands-free torque wrench solution suitable for Enerpac only square drive tools.

Suitable for:

RSQ3000, RSQ5000, RSQ11000

Page: 246



Torque Wrench Pumps

Visit enerpac.com for system matched air and electric torque wrench pumps that are ideal for use with hydraulic torque wrenches.

Page: 291

▼ Shown: DSX11000



Setting Industry-First Safety Standards



Work-at-Height Connection

Built-in, work-at-height safety tether.



Fully Retained Reaction Arm

Patented, fully retained reaction arm with easy-to-use quick release, helps prevent injuries when working-at-height.



Secured Square Drive

Retained quick release push-button.



Ergonomic Tool Handle

Robust ergonomic positioning handle comes standard with every DSX tool.

SWH10EA is an eyebolt handle.

Compatible DSX-Series wrenches	Ergonomic Handle (Standard)
DSX1500, 3000, 5000	SWH6A
DSX11000	SWH10A
DSX25000	SWH10EA



Bolting Integrity Software

Enerpac Bolting Integrity Software Solutions play a key role in implementing and managing an Integrity Program for bolted connections. The software offers Tool selection, Bolt Load calculations and Tool pressure settings, as well as, a combined Application Data Sheet and Joint Completion Report. Custom Joint information can also be entered.

Safety and Performance

- High-strength, lightweight aluminum, slimline design suited for complete operator safety
- Fully enclosed drive for maximum safety
- Built-in, work-at-height safety tether connection
- Retained quick release push-button
- Patented, easy-to-use, quick release, retained reaction arm
- Fine-tooth ratchet prevents the tool 'locking on'
- High-cycle design with fewer moving parts making it a more efficient tool to operate, maintain, or repair
- 35° rotation angle and rapid return stroke for fast operation

Simplicity

- Robust handle which mounts on either side of the tool for extra maneuverability and safer operation
- Push-button square drive and reaction arm for fast changes and adjustments
- Easily accessible work-at-height connection point

Accuracy

- Constant torque output provides accuracy of +/-3% across full stroke

ATEX certified

- All DSX tools are CE - ATEX certified

Square Drive Hydraulic Torque Wrenches

Standard are ① ② ③ ④ ⑤.
⑥ is optional.

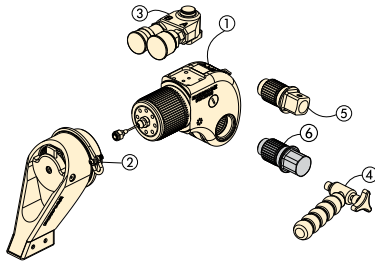

- ① Drive Unit
- ② Reaction Arm
- ③ Aluminum Swivel
- ④ Ergonomic Tool Handle
- ⑤ Square Drive
- ⑥ Allen® Drive (optional)



Select the Right Torque

Choose your Enerpac Torque Wrench using the untightening rule of thumb: Loosening torque equals about 250% of tightening torque.

DSX Series



Nominal Torque Output:

24,057 ft.lbs

Square Drive Range:

3/4 - 2 1/2 inches

Nose Radius:

0.94 - 2.50 inches

Maximum Operating Pressure:

10,000 psi

TORQUE WRENCH SELECTION

(based on hexagon socket sizes)

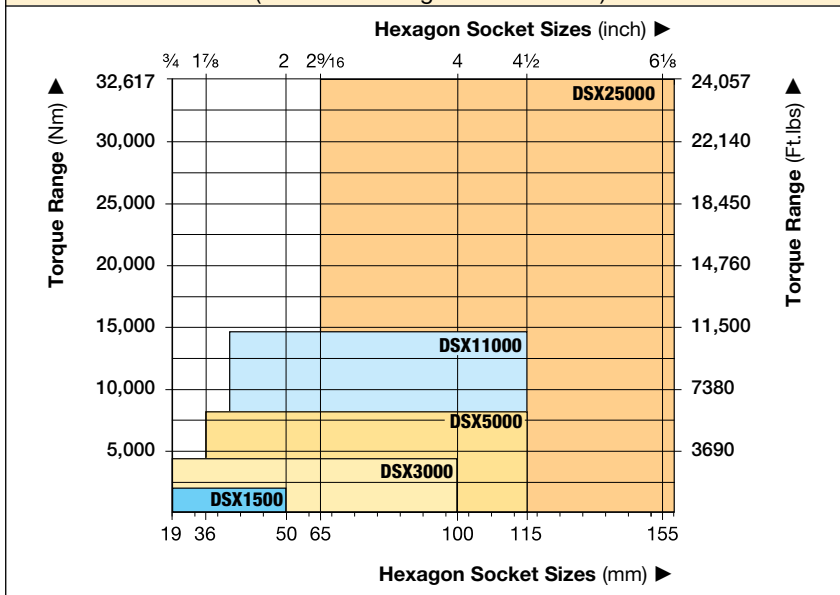

Back-Up Spanners

Hands free tool to be used to stop back nut from turning during make up or break out.

Page: 245

▼ The rigid design of the DSX-Series torque wrenches provides durability, reliability and safety.





Use only Heavy-Duty Impact Sockets

For power driven torquing equipment, according to ISO2725 and ISO1174; DIN 3129 and DIN 3121 or ASME-B107.2/1995.

Page: 248

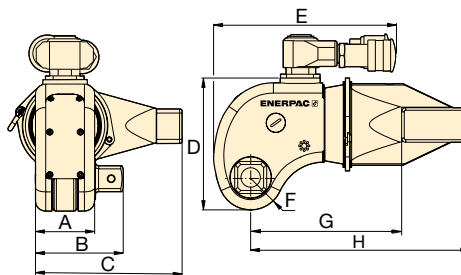

Nominal Torque at 10,000 psi / 690 bar		Minimum Torque at 1000 psi / 69 bar		Square Drive		Torque Wrench Model No.	Dimensions (in)								Wt.
(Ft.lbs)	(Nm)	(Ft.lbs)	(Nm)	Size (inch)	Model No. (included with wrench)		A	B	C	D	E	F	G	H	(lbs)
1411	1913	141	191	3/4	DSX1500-08	DSX1500	1.7	2.6	4.2	3.7	5.7	0.94	4.4	6.4	4.8
3233	4383	323	438	1	DSX3000-08	DSX3000	2.3	3.4	5.7	5.1	6.7	1.25	5.8	8.5	10.6
5635	7640	563	764	1 1/2	DSX5000-08	DSX5000	2.7	4.4	6.8	5.8	7.6	1.50	7.1	10.2	17.9
11,000	14,914	1100	1491	1 1/2	DSX11000-08	DSX11000	3.4	5.1	8.5	7.2	8.7	1.88	8.94	12.8	31.7
24,057	32,617	2406	3262	2 1/2	DSX25000-08	DSX25000	4.6	6.9	11.3	9.6	10.5	2.50	11.1	18.2	71.7

Maximum Torque Output:

24,057 ft.lbs

Hexagon Size Allen® Drive:

1/2 - 2 1/4 inches

Hexagon Size Allen® Drive:

14 - 85 mm

For
DSX
Series



Torque Wrench	Optional Allen® Drives, Imperial				Optional Allen® Drives, Metric			
	Hexagon Size	Maximum Torque	Model Number	Dim. B1	Hexagon Size	Maximum Torque	Model Number	Dim. B1
(max. torque)	(in)	(Ft.lbs)		(in)	(mm)	(Nm)		(mm)
DSX1500 (1411 Ft.lbs) (1913 Nm)	1/2	350	DDA15008	2.64	14	644	DDA1514	67
	5/8	690	DDA15010	2.64	17	1152	DDA1517	67
	3/4	1200	DDA15012	2.64	19	1627	DDA1519	67
	7/8	1411	DDA15014	2.64	22	1913	DDA1522	67
	1	1411	DDA15100	2.64	24	1913	DDA1524	67
DSX3000 (3233 Ft.lbs) (4383 Nm)	5/8	690	DDA30010	3.39	17	1152	DDA3017	86
	3/4	1200	DDA30012	3.39	19	1627	DDA3019	86
	7/8	1900	DDA30014	3.39	22	2495	DDA3022	86
	1	2830	DDA30100	3.39	24	3376	DDA3024	86
	1 1/8	3233	DDA30102	3.39	27	4383	DDA3027	86
	1 1/4	3233	DDA30104	3.39	30	4383	DDA3030	86
	-	-	-	3.39	32	4383	DDA3032	86
DSX5000 (5635 Ft.lbs) (7640 Nm)	5/8	690	DDA50010	4.41	17	1152	DDA5017	112
	3/4	1200	DDA50012	4.41	19	1627	DDA5019	112
	7/8	1900	DDA50014	4.41	22	2495	DDA5022	112
	1	2830	DDA50100	4.41	24	3376	DDA5024	112
	1 1/8	5325	DDA50102	4.41	27	4610	DDA5027	112
	1 1/4	5635	DDA50104	4.41	30	7640	DDA5030	112
	-	-	-	-	32	7640	DDA5032	112
DSX11000 (11,000 Ft.lbs) (14,914 Nm)	1 1/4	5635	DDA110104	5.08	30	7640	DDA11030	129
	1 3/8	9958	DDA110106	5.08	32	7640	DDA11032	129
	1 1/2	9958	DDA110108	5.08	36	10,846	DDA11036	129
	1 5/8	11,000	DDA110110	5.08	41	14,914	DDA11041	129
	1 3/4	11,000	DDA110112	5.08	46	14,914	DDA11046	129
DSX25000 (24,057 Ft.lbs) (32,617 Nm)	1 1/2	9958	DDA250104	6.93	36	10,846	DDA25036	176
	1 5/8	16,433	DDA250106	6.93	41	16,107	DDA25041	176
	1 3/4	15,200	DDA250112	6.93	46	22,777	DDA25046	176
	1 7/8	22,777	DDA250114	6.93	50	29,211	DDA25050	176
	2	24,057	DDA250200	6.93	55	32,617	DDA25055	176
	2 1/4	24,057	DDA250204	6.93	60	32,617	DDA25060	176
	-	-	-	-	65	32,617	DDA25065	176
	-	-	-	-	70	32,617	DDA25070	176
	-	-	-	-	75	32,617	DDA25075	176
	-	-	-	-	85	32,617	DDA25085	176

Bolting Applications & Portable Machining

Enerpac professional bolting tools provide reliable controlled torque and tension solutions across the industry.

Portable machining products tackle the most demanding in-situ machining applications.

W-Series torque wrench providing accurate and repeatable results

Large numbers of fasteners require precise application of torque to ensure joint integrity is achieved and maintained. The Enerpac W-Series wrench was selected as it offers simple and reliable operation. The portable Enerpac E-Pulse torque pump was used and is ideal for high volume fastening applications where weight is a critical factor.



Safe, reliable, and repeatable tensioning with compact HydraMax® Tensioners to complete joint integrity

With their compact fit and high load generation, and the flexibility to work with all standard flanges, the Enerpac HM-Series HydraMax® tensioners can be used in almost every industry and in many different applications.

Portable Machining

Mirage® portable machining products tackle the most demanding in-situ machining applications. By replicating machine shop tolerances in-situ, customers can reliably get the job done faster, safer and smarter.

See pages 378-397 for more information.

Oil & Gas: Pipeline repair under pressure; Wellhead high-pressure drilling; Raised, RTJ, compact flanges and hubs; Flange stud removal; Re-thread damaged holes

Power Generation: Pipe cutting and weld preparation; Wind turbine blade and tower milling; Turbine casing split line repairs; Subsea cutting and decommissioning.



▼ HMT-Drive Units with interchangeable HLP-Low-Profile Cassette and HSQ-Square Drive Cassette



Modular, Durable, Fast and Efficient Torque for Low-Profile and Square Drive Applications

The HMT-Series is a range of fast, durable and efficient modular hydraulic torque wrenches, enabling you to tackle almost any bolting application. Interchange cassettes with ease, switching the HLP low-profile hexagon cassette with the HSQ square drive whenever your application demands.

As an added benefit, tools and cassettes are interchangeable with many other well-known brands, allowing you the freedom to use the tools at your disposal while reducing the cost of upgrading your legacy torque wrench inventory to high quality Enerpac equipment.

The tool itself has been carefully designed and manufactured, utilizing superior alloys and surface treatments to make it lightweight, up to 25% faster and more than twice as durable as other tools in the same class.

Safety and Performance

- Supplied with an ergonomic tool safety handle as standard
- The HMT Modular Torque/Tool is also supplied with a link pin retainer as standard

Versatility

- Interchangeable with other manufacturers
- HMT is able to solve all of your bolting challenges quickly and safely, with one or more attachment options, making it suitable for any application

Simplicity

- The HMT is part of a modular system which is made up of a single power head and one attachment; the HMT Drive Unit and HLP Hexagon cassette or HSQ Square Drive Cassette

Accuracy

- Constant torque output provides accuracy of +/-3% across full stroke



Torque Wrench Options and Accessories

Optional accessories are available for maximum versatility.

Page: 283



Back-Up Spanners

Hands free tool to be used to stop back nut from turning during make up or break out. Two hexagon sizes in one tool.

Page: 245



Torque Wrench Pumps

Visit enerpac.com for system matched air and electric torque wrench pumps that are ideal for use with hydraulic torque wrenches.

Page: 291



Torque Wrench Hoses

Use Enerpac THQ-Series hoses with HMT-Series torque wrenches to ensure the integrity of your hydraulic system.

6 feet long, 2 hoses	THQ702T
19.5 feet long, 2 hoses	THQ706T
39 feet long, 2 hoses	THQ712T

Drive Units for Hexagon & Square Drive Cassettes



One Drive, Two Tools

One HMT-Hydraulic Torque Wrench fits HLP Low-Profile or HSQ Square Drive cassette.

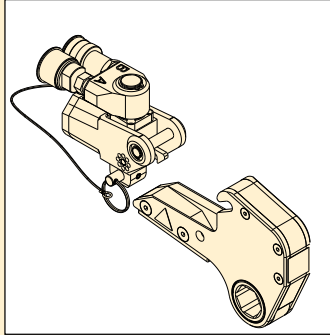

HMT...HLP

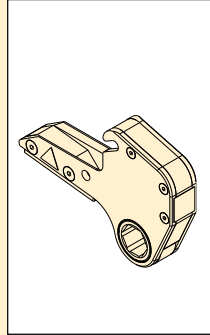

HLP

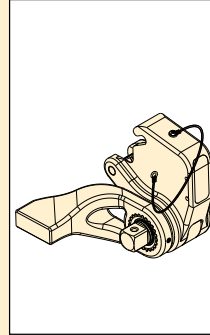

HSQ

HMT Series



Max. Torque at 10,000 psi:

1541 - 13,489 ft.lbs

Max. Torque at 690 bar:

2089 - 18,289 Nm

Hexagon Range:

1 1/16 - 4 5/8" / 26 - 115 mm

Maximum Operating Pressure:

10,000 psi / 690 bar

HMT-Series, Torque Wrench Options and Accessories

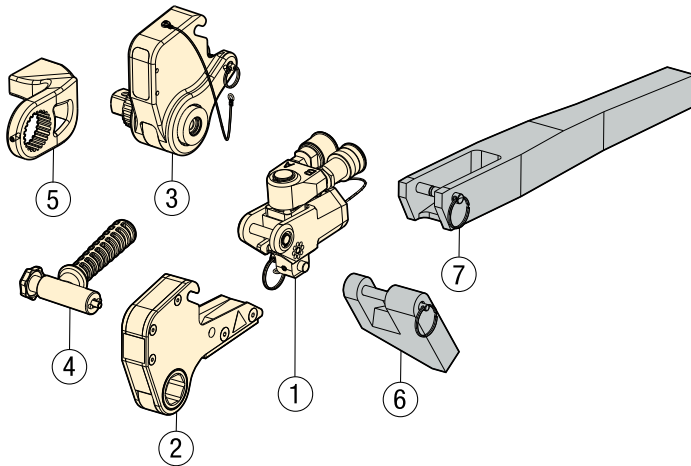

- ① HMT: Drive Unit (page 279)
- ② HLP: Hexagon Cassette (page 280-281)
- ③ HSQ: Square Drive Cassette (page 282-283)
- ④ SWH: Ergonomic Tool Handle (page 282)
- ⑤ Reaction Arm for HSQ
- ⑥ HRP: Reaction Paddle (page 280)
- ⑦ HTE: Extended Reaction Arm (page 280)

Optional Parts (for HMT with HLP only)



Select the Right Torque

250%
Choose your Enerpac Torque Wrench using the untightening rule of thumb: Loosening torque equals about 250% of tightening torque.



HLP Low-Profile Cassettes

For the metric and imperial Low-Profile cassettes see:

Page: 280



HSQ Square Drive Cassettes

For the metric and imperial Square Drive Cassettes see:

Page: 282

SELECTION CHART

Max. Torque Output at 10,000 psi		Min. Torque Output at 1000 psi		Drive Unit Model Number	Dimensions (in)			Wt. (lbs)	Dimensions (mm)			Wt. (kg)
(ft-lbs)	(Nm)	(ft-lbs)	(Nm)		A	B	C		A	B	C	
1541	2089	154	209	 HMT1500	4.3	4.1	2.0	2.20	108	104	49	1,0
3750	5084	375	508	HMT3500	5.7	5.2	2.6	3.97	146	132	66	1,8
7562	10252	756	1025	HMT7500	7.1	6.4	3.2	7.05	180	163	82	3,2
13489	18289	1349	1829	HMT13000*	8.5	7.4	3.9	4.40	216	187	98	9,7

* Note: HMT13000 only available for HLP-low profile hexagon cassettes.

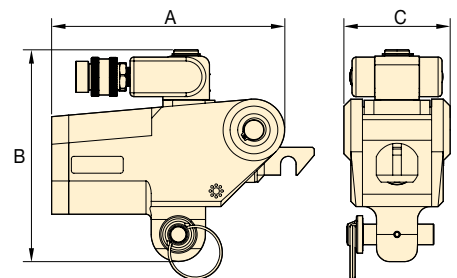

HLP-Series Cassettes for HMT Drive Units

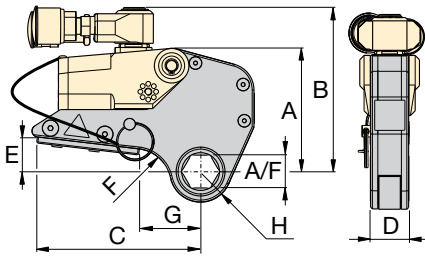

Hexagon Range:

1¹/₁₆ - 4⁵/₈ inches

Hexagon Range:

26 - 115 mm

Maximum Operating Pressure:

10,000 psi

HLP Series



▼ **SELECTION CHART**

IMPORTANT: HMT-drive units must be ordered separately to operate the HLP-Hexagon Cassettes.

Drive Unit Model Number	Hexagon Size		Hexagon Cassette Model Number	Maximum Torque Output		Dimensions (in)								Wt. (lbs)	Dimensions (mm)								Wt. (kg)
	(in)	(mm)		(ft-lbs)	(Nm)	A	B	C	D	E	F	G	H		A	B	C	D	E	F	G	H	
HMT1500	1 ¹ / ₁₆	26	HLP1101	1541	2089	4.48	5.32	5.35	1.2	1.13	1.18	2.01	1.00	3.53	114	135	136	31,5	29	30	51	25	1,6
	1 ¹ / ₈	-	HLP1102	1541	2089	4.48	5.32	5.35	1.2	1.13	1.18	2.01	1.00	3.53	114	135	136	31,5	29	30	51	25	1,6
	1 ³ / ₁₆	30	HLP1103	1541	2089	4.48	5.32	5.35	1.2	1.13	1.18	2.01	1.00	3.53	114	135	136	31,5	29	30	51	25	1,6
	1 ¹ / ₄	32	HLP1104	1541	2089	4.48	5.32	5.35	1.2	1.13	0.95	2.01	1.08	3.53	114	135	136	31,5	29	24	51	27	1,6
	1 ⁵ / ₁₆	33	HLP1105	1541	2089	4.48	5.32	5.35	1.2	1.13	0.95	2.01	1.08	3.53	114	135	136	31,5	29	24	51	27	1,6
	1 ³ / ₈	35	HLP1106	1541	2089	4.48	5.32	5.35	1.2	1.13	0.55	1.89	1.19	3.53	114	135	136	31,5	29	14	48	30	1,6
	1 ⁷ / ₁₆	36	HLP1107	1541	2089	4.48	5.32	5.35	1.2	1.13	0.55	1.89	1.19	3.53	114	135	136	31,5	29	14	48	30	1,6
	1 ¹ / ₂	38	HLP1108	1541	2089	4.48	5.32	5.35	1.2	1.13	0.55	2.01	1.30	3.53	114	135	136	31,5	29	14	51	33	1,6
	1 ⁹ / ₁₆	-	HLP1109	1541	2089	4.48	5.32	5.35	1.2	1.13	0.55	2.01	1.30	3.53	114	135	136	31,5	29	14	51	33	1,6
	1 ⁵ / ₈	41	HLP1110	1541	2089	4.48	5.32	5.35	1.2	1.13	0.55	2.01	1.30	3.53	114	135	136	31,5	29	14	51	33	1,6
	1 ¹¹ / ₁₆	-	HLP1111	1541	2089	4.48	5.32	5.35	1.2	1.13	0.55	2.01	1.30	3.53	114	135	136	31,5	29	14	51	33	1,6
	1 ³ / ₄	-	HLP1112	1541	2089	4.48	5.32	5.35	1.2	1.13	0.55	2.01	1.38	3.53	114	135	136	31,5	29	14	51	35	1,6
	1 ¹³ / ₁₆	46	HLP1113	1541	2089	4.48	5.32	5.35	1.2	1.13	0.55	2.01	1.38	3.53	114	135	136	31,5	29	14	51	35	1,6
	1 ⁷ / ₈	-	HLP1114	1541	2089	4.48	5.32	5.35	1.2	1.13	0.55	2.36	1.52	3.53	114	135	136	31,5	29	14	60	39	1,6
	1 ¹⁵ / ₁₆	-	HLP1115	1541	2089	4.48	5.32	5.35	1.2	1.13	0.55	2.36	1.52	3.53	114	135	136	31,5	29	14	60	39	1,6
	2	50	HLP1200	1541	2089	4.48	5.32	5.35	1.2	1.13	0.55	2.36	1.52	3.75	114	135	136	31,5	29	14	60	39	1,7
	2 ¹ / ₁₆	-	HLP1201	1541	2089	4.48	5.32	5.35	1.2	1.13	0.55	2.36	1.52	3.75	114	135	136	31,5	29	14	60	39	1,7
	2 ¹ / ₈	-	HLP1202	1541	2089	4.48	5.32	5.35	1.2	1.13	0.55	2.36	1.65	3.75	114	135	136	31,5	29	14	60	42	1,7
	2 ³ / ₁₆	55	HLP1203	1541	2089	4.48	5.32	5.35	1.2	1.13	0.55	2.36	1.65	3.75	114	135	136	31,5	29	14	60	42	1,7
	2 ¹ / ₄	-	HLP1204	1541	2089	4.48	5.32	5.35	1.2	1.13	0.55	2.36	1.65	3.75	114	135	136	31,5	29	14	60	42	1,7
	2 ⁵ / ₁₆	-	HLP1205	1541	2089	4.48	5.32	5.35	1.2	1.13	0.55	2.36	1.65	3.75	114	135	136	31,5	29	14	60	42	1,7
	2 ³ / ₈	60	HLP1206	1541	2089	4.48	5.32	5.35	1.2	1.13	0.55	2.36	1.71	3.75	114	135	136	31,5	29	14	60	44	1,7
	2 ⁷ / ₁₆	62	HLP1207	1541	2089	4.48	5.32	5.35	1.2	1.13	0.55	2.36	1.71	3.75	114	135	136	31,5	29	14	60	44	1,7
	HMT3500	1 ³ / ₈	35	HLP3106	3750	5084	6.02	6.57	7.24	1.7	1.59	1.89	3.09	1.30	8.60	153	167	184	42,0	41	48	79	33
1 ⁷ / ₁₆		36	HLP3107	3750	5084	6.02	6.57	7.24	1.7	1.59	1.89	3.09	1.30	8.60	153	167	184	42,0	41	48	79	33	3,9
1 ¹ / ₂		38	HLP3108	3750	5084	6.02	6.57	7.24	1.7	1.59	1.81	3.16	1.42	8.60	153	167	184	42,0	41	46	80	36	3,9
1 ⁹ / ₁₆		-	HLP3109	3750	5084	6.02	6.57	7.24	1.7	1.59	1.81	3.16	1.42	8.60	153	167	184	42,0	41	46	80	36	3,9
1 ⁵ / ₈		41	HLP3110	3750	5084	6.02	6.57	7.24	1.7	1.59	1.81	3.16	1.42	8.60	153	167	184	42,0	41	46	80	36	3,9
1 ¹¹ / ₁₆		-	HLP3111	3750	5084	6.02	6.57	7.24	1.7	1.59	1.81	3.16	1.42	8.60	153	167	184	42,0	41	46	80	36	3,9
1 ³ / ₄		-	HLP3112	3750	5084	6.02	6.57	7.24	1.7	1.59	1.58	3.08	1.52	8.60	153	167	184	42,0	41	40	78	39	3,9
1 ¹³ / ₁₆		46	HLP3113	3750	5084	6.02	6.57	7.24	1.7	1.59	1.58	3.08	1.52	8.60	153	167	184	42,0	41	40	78	39	3,9
1 ⁷ / ₈		-	HLP3114	3750	5084	6.02	6.57	7.24	1.7	1.59	1.42	3.05	1.63	8.60	153	167	184	42,0	41	36	77	41	3,9
1 ¹⁵ / ₁₆		-	HLP3115	3750	5084	6.02	6.57	7.24	1.7	1.59	1.42	3.05	1.63	8.60	153	167	184	42,0	41	36	77	41	3,9
2		50	HLP3200	3750	5084	6.02	6.57	7.24	1.7	1.59	1.42	3.05	1.63	8.60	153	167	184	42,0	41	36	77	41	3,9
2 ¹ / ₁₆		-	HLP3201	3750	5084	6.02	6.57	7.24	1.7	1.59	1.42	3.05	1.63	8.82	153	167	184	42,0	41	36	77	41	4,0
2 ¹ / ₈		-	HLP3202	3750	5084	6.02	6.57	7.24	1.7	1.59	1.18	2.97	1.74	8.82	153	167	184	42,0	41	30	75	44	4,0
2 ³ / ₁₆		55	HLP3203	3750	5084	6.02	6.57	7.24	1.7	1.59	1.18	2.97	1.74	8.82	153	167	184	42,0	41	30	75	44	4,0
2 ¹ / ₄		-	HLP3204	3750	5084	6.02	6.57	7.24	1.7	1.59	1.18	2.97	1.74	8.82	153	167	184	42,0	41	30	75	44	4,0
2 ⁵ / ₁₆		-	HLP3205	3750	5084	6.02	6.57	7.24	1.7	1.59	0.63	2.68	1.85	9.04	153	167	184	42,0	41	16	68	47	4,1
2 ³ / ₈		60	HLP3206	3750	5084	6.02	6.57	7.24	1.7	1.59	0.63	2.68	1.85	9.04	153	167	184	42,0	41	16	68	47	4,1
2 ⁷ / ₁₆		62	HLP3207	3750	5084	6.02	6.57	7.24	1.7	1.59	0.63	2.80	1.85	9.04	153	167	184	42,0	41	16	71	47	4,1
2 ¹ / ₂		63	HLP3208	3750	5084	6.02	6.57	7.24	1.7	1.59	0.63	2.80	1.96	9.04	153	167	184	42,0	41	16	71	50	4,1
2 ⁹ / ₁₆		65	HLP3209	3750	5084	6.02	6.57	7.24	1.7	1.59	0.63	2.80	1.96	9.04	153	167	184	42,0	41	16	71	50	4,1
2 ⁵ / ₈		-	HLP3210	3750	5084	6.02	6.57	7.24	1.7	1.59	0.63	2.80	2.07	9.04	153	167	184	42,0	41	16	71	53	4,1
2 ¹¹ / ₁₆		-	HLP3211	3750	5084	6.02	6.57	7.24	1.7	1.59	0.63	2.80	2.07	9.04	153	167	184	42,0	41	16	71	53	4,1
2 ³ / ₄		70	HLP3212	3750	5084	6.02	6.57	7.24	1.7	1.59	0.63	2.80	2.07	9.04	153	167	184	42,0	41	16	71	53	4,1
2 ¹³ / ₁₆		-	HLP3213	3750	5084	6.02	6.57	7.24	1.7	1.59	0.63	2.80	2.07	9.04	153	167	184	42,0	41	16	71	53	4,1
2 ⁷ / ₈	-	HLP3214	3750	5084	6.02	6.57	7.24	1.7	1.59	0.63	2.80	2.07	9.04	153	167	184	42,0	41	16	71	53	4,1	
2 ¹⁵ / ₁₆	75	HLP3215	3750	5084	6.02	6.57	7.24	1.7	1.59	0.63	2.99	2.19	9.04	153	167	184	42,0	41	16	76	56	4,1	
3	-	HLP3300	3750	5084	6.02	6.57	7.24	1.7	1.59	0.63	2.99	2.19	9.04	153	167	184	42,0	41	16	76	56	4,1	
3 ¹ / ₁₆	-	HLP3301	3750	5084	6.02	6.57	7.24	1.7	1.59	0.63	2.99	2.19	9.04	153	167	184	42,0	41	16	76	56	4,1	
3 ¹ / ₈	80	HLP3302	3750	5084	6.02	6.57	7.24	1.7	1.59	0.63	2.99	2.19	9.04	153	167	184	42,0	41	16	76	56	4,1	

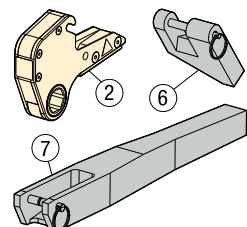

Optional Parts for HLP-Hexagon Cassettes

- Full torque rated
- Includes pin to secure onto HLP-cassette
- ⑥ HRP: allows offset reaction when in-line reaction point is not available
- ⑦ HTE: Increases tool fit in restricted areas.

For HMT with HLP-Series Hexagon Cassettes	Reaction Paddle Model No. ⑥	Extended Reaction Arm Model No. ⑦
HMT1500 + HLP1	HRP15	HTE15
HMT3500 + HLP3	HRP35	HTE35
HMT7500 + HLP7	HRP75	HTE75
HMT13000 + HLP13	HRP130	HTE130

HLP-Series Hexagon Cassettes for HMT Drive Units

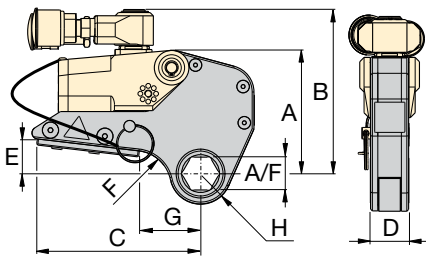

Hexagon Range:
1¹/₁₆ - 4⁵/₈ inches

Hexagon Range:
26 - 115 mm

Maximum Operating Pressure:
10,000 psi

**HLP
Series**



▼ SELECTION CHART

IMPORTANT: HMT-drive units must be ordered separately to operate the HLP-Hexagon Cassettes.

Drive Unit Model Number	Hexagon Size		Hexagon Cassette Model Number	Maximum Torque Output		Dimensions (in)								Wt. (lbs)	Dimensions (mm)								Wt. (kg)	
	(in)	(mm)		(ft-lbs)	(Nm)	A	B	C	D	E	F	G	H		A	B	C	D	E	F	G	H		
HMT7500	2³/₁₆	55	HLP7203	7562	10.252	7.60	8.01	8.94	2.1	1.81	1.65	3.39	1.91	15.65	193	203	227	52.6	46	42	86	49	7.1	
	2¹/₄	-	HLP7204	7562	10.252	7.60	8.01	8.94	2.1	1.81	1.65	3.39	1.91	15.65	193	203	227	52.6	46	42	86	49	7.1	
	2⁵/₁₆	-	HLP7205	7562	10.252	7.60	8.01	8.94	2.1	1.81	1.65	3.39	1.91	15.65	193	203	227	52.6	46	42	86	49	7.1	
	2³/₈	60	HLP7206	7562	10.252	7.60	8.01	8.94	2.1	1.81	1.18	3.15	1.99	15.65	193	203	227	52.6	46	30	80	51	7.1	
	2⁷/₁₆	62	HLP7207	7562	10.252	7.60	8.01	8.94	2.1	1.81	1.18	3.15	1.99	15.65	193	203	227	52.6	46	30	80	51	7.1	
	2¹/₂	63	HLP7208	7562	10.252	7.60	8.01	8.94	2.1	1.81	1.18	3.15	1.99	15.65	193	203	227	52.6	46	30	80	51	7.1	
	2⁹/₁₆	65	HLP7209	7562	10.252	7.60	8.01	8.94	2.1	1.81	0.87	3.15	2.07	15.65	193	203	227	52.6	46	22	80	53	7.1	
	2⁵/₈	-	HLP7210	7562	10.252	7.60	8.01	8.94	2.1	1.81	0.79	3.15	2.19	15.65	193	203	227	52.6	46	20	80	56	7.1	
	2¹¹/₁₆	-	HLP7211	7562	10.252	7.60	8.01	8.94	2.1	1.81	0.79	3.15	2.19	15.65	193	203	227	52.6	46	20	80	56	7.1	
	2³/₄	70	HLP7212	7562	10.252	7.60	8.01	8.94	2.1	1.81	0.79	3.15	2.19	17.42	193	203	227	52.6	46	20	80	56	7.9	
	2¹³/₁₆	-	HLP7213	7562	10.252	7.60	8.01	8.94	2.1	1.81	0.79	3.15	2.19	17.42	193	203	227	52.6	46	20	80	56	7.9	
	2⁷/₈	-	HLP7214	7562	10.252	7.60	8.01	8.94	2.1	1.81	0.79	3.15	2.19	17.42	193	203	227	52.6	46	20	80	56	7.9	
	2¹⁵/₁₆	75	HLP7215	7562	10.252	7.60	8.01	8.94	2.1	1.81	0.67	3.15	2.26	17.42	193	203	227	52.6	46	17	80	58	7.9	
	3	-	HLP7300	7562	10.252	7.60	8.01	8.94	2.1	1.81	0.67	3.39	2.38	17.42	193	203	227	52.6	46	17	86	61	7.9	
	3¹/₁₆	-	HLP7301	7562	10.252	7.60	8.01	8.94	2.1	1.81	0.67	3.39	2.38	17.42	193	203	227	52.6	46	17	86	61	7.9	
	3¹/₈	80	HLP7302	7562	10.252	7.60	8.01	8.94	2.1	1.81	0.67	3.39	2.38	17.42	193	203	227	52.6	46	17	86	61	7.9	
	3¹/₄	-	HLP7304	7562	10.252	7.60	8.01	8.94	2.1	1.81	0.67	3.39	2.52	17.42	193	203	227	52.6	46	17	86	64	7.9	
	-	85	HLP7085M	7562	10.252	7.60	8.01	8.94	2.1	1.81	0.67	3.39	2.52	17.42	193	203	227	52.6	46	17	86	64	7.9	
	3³/₈	-	HLP7306	7562	10.252	7.60	8.01	8.94	2.1	1.81	0.67	3.39	2.52	17.42	193	203	227	52.6	46	17	86	64	7.9	
	3⁷/₁₆	-	HLP7307	7562	10.252	7.60	8.01	8.94	2.1	1.81	0.67	3.50	2.52	17.64	193	203	227	52.6	46	17	89	64	8.0	
	3¹/₂	-	HLP7308	7562	10.252	7.60	8.01	8.94	2.1	1.81	0.67	3.50	2.64	17.64	193	203	227	52.6	46	17	89	67	8.0	
	-	90	HLP7090M	7562	10.252	7.60	8.01	8.94	2.1	1.81	0.67	3.74	2.64	17.64	193	203	227	52.6	46	17	95	67	8.0	
	3⁹/₁₆	-	HLP7309	7562	10.252	7.60	8.01	8.94	2.1	1.81	0.67	3.74	2.78	17.64	193	203	227	52.6	46	17	95	71	8.0	
	3³/₄	95	HLP7312	7562	10.252	7.60	8.01	8.94	2.1	1.81	0.67	3.74	2.89	18.08	193	203	227	52.6	46	17	95	71	8.2	
	3⁷/₈	-	HLP7314	7562	10.252	7.60	8.01	8.94	2.1	1.81	0.67	3.74	2.89	18.08	193	203	227	52.6	46	17	95	74	8.2	
	3¹⁵/₁₆	100	HLP7315	7562	10.252	7.60	8.01	8.94	2.1	1.81	0.67	3.74	2.89	18.08	193	203	227	52.6	46	17	95	74	8.2	
	HMT13000	2⁷/₁₆	62	HLP13207	13.489	18.289	8.03	9.53	10.87	2.50	2.25	2.95	4.69	2.28	24.3	204	242	276	63.4	57	75	119	58.0	11.0
		2¹/₂	63	HLP13208	13.489	18.289	8.03	9.53	10.87	2.50	2.25	2.95	4.69	2.28	24.3	204	242	276	63.4	57	75	119	58.0	11.0
2⁹/₁₆		65	HLP13209	13.489	18.289	8.03	9.53	10.87	2.50	2.25	2.95	4.69	2.28	24.3	204	242	276	63.4	57	75	119	58.0	11.0	
2⁵/₈		67	HLP13210	13.489	18.289	8.03	9.53	10.87	2.50	2.25	2.95	4.69	2.28	24.3	204	242	276	63.4	57	75	119	58.0	11.0	
2¹¹/₁₆		68	HLP13211	13.489	18.289	8.03	9.53	10.87	2.50	2.25	2.95	4.69	2.28	24.3	204	242	276	63.4	57	75	119	58.0	11.0	
2³/₄		70	HLP13212	13.489	18.289	8.03	9.53	10.87	2.50	2.25	2.95	4.69	2.28	24.3	204	242	276	63.4	57	75	119	58.0	11.0	
2¹³/₁₆		71	HLP13213	13.489	18.289	8.03	9.53	10.87	2.50	2.25	2.95	4.69	2.28	24.3	204	242	276	63.4	57	75	119	58.0	11.0	
2⁷/₈		73	HLP13214	13.489	18.289	8.03	9.53	10.87	2.50	2.25	2.95	4.69	2.28	24.3	204	242	276	63.4	57	75	119	58.0	11.0	
2¹⁵/₁₆		75	HLP13215	13.489	18.289	8.03	9.53	10.87	2.50	2.25	2.76	4.69	2.40	24.3	204	242	276	63.4	57	70	119	61.0	11.0	
3		77	HLP13300	13.489	18.289	8.03	9.53	10.87	2.50	2.25	2.76	4.88	2.56	24.3	204	242	276	63.4	57	70	124	65.0	11.0	
3¹/₁₆		78	HLP13301	13.489	18.289	8.03	9.53	10.87	2.50	2.25	2.76	4.88	2.56	24.3	204	242	276	63.4	57	70	124	65.0	11.0	
3¹/₈		80	HLP13302	13.489	18.289	8.03	9.53	10.87	2.50	2.25	2.76	4.88	2.56	24.3	204	242	276	63.4	57	70	124	65.0	11.0	
3³/₁₆		81	HLP13303	13.489	18.289	8.03	9.53	10.87	2.50	2.25	2.76	4.88	2.58	24.3	204	242	276	63.4	57	70	124	65.5	11.0	
3¹/₄		83	HLP13304	13.489	18.289	8.03	9.53	10.87	2.50	2.25	2.76	4.88	2.58	24.3	204	242	276	63.4	57	70	124	65.5	11.0	
3⁵/₁₆		84	HLP13305	13.489	18.289	8.03	9.53	10.87	2.50	2.25	2.76	4.88	2.58	24.3	204	242	276	63.4	57	70	124	65.5	11.0	
-		85	HLP13085M	13.489	18.289	8.03	9.53	10.87	2.50	2.25	2.76	4.88	2.58	24.3	204	242	276	63.4	57	70	124	65.5	11.0	
3³/₈		86	HLP13306	13.489	18.289	8.03	9.53	10.87	2.50	2.25	2.76	4.88	2.58	24.3	204	242	276	63.4	57	70	124	65.5	11.0	
3⁷/₁₆		-	HLP13307	13.489	18.289	8.03	9.53	10.87	2.50	2.25	2.36	4.88	2.76	24.3	204	242	276	63.4	57	60	124	70.0	11.0	
3¹/₂		89	HLP13308	13.489	18.289	8.03	9.53	10.87	2.50	2.25	2.36	4.88	2.76	24.3	204	242	276	63.4	57	60	124	70.0	11.0	
-		90	HLP13090M	13.489	18.289	8.03	9.53	10.87	2.50	2.25	2.36	4.88	2.76	26.5	204	242	276	63.4	57	60	124	70.0	12.0	
3⁹/₁₆		91	HLP13309	13.489	18.289	8.03	9.53	10.87	2.50	2.25	1.34	4.33	2.91	26.5										

HSQ-Series, Square Drive Torque Wrenches **ENERPAC**

▼ HMT drive unit with HSQ square drive cassette



Modular, Durable, Fast and Efficient Torque for Low Profile and Square Drive Applications

Safety and Performance

- Innovative design that completely encloses all moving parts and minimizes pinch points
- Supplied reaction arm as standard
- Fully adjustable 360 degree in-line reaction arm
- Fine tooth ratchet prevents locking-on

Simplicity

- Simple robust design with just three moving parts for reduced maintenance
- Push button, quick release, reversible square drive

Versatility

- The reaction arm, positioned around the square drive instead of the back of the drive unit, provides you with the possibility to turn the drive unit away from an obstacle

Accuracy

- Constant torque output provides accuracy of +/-3% across full stroke

ATEX certified

- All HMT tools are CE - ATEX certified



Ergonomic Tool Handle

Robust ergonomic positioning handle comes standard with every HMT Drive Unit.

Compatible HMT-Series wrenches	Ergonomic Handle (Standard)
HMT1500, 3500, 7500	SWH6A
HMT13000	SWH10A



Back-Up Spanners

Hands free tool to be used to stop back nut from turning during make up or break out. Two hexagon sizes in one tool.

Page:  245



Torque Wrench Hoses

Use Enerpac THQ-Series hoses with HMT-Series torque wrenches to ensure the integrity of your hydraulic system.

6 feet long, 2 hoses	THQ702T
19.5 feet long, 2 hoses	THQ706T
39 feet long, 2 hoses	THQ712T

HSQ, Square Drive Hydraulic Torque Wrenches



Bolting Integrity Software

Visit enerpac.com to access our free on-line

bolting software application. A comprehensive on-line software solution for Bolted Joint integrity.

Integral databases hold data for:

- BS1560, MSS SP44, API 6A and 17D flanged joints
- Common gasket materials and configurations
- Comprehensive range of bolt materials
- Comprehensive range of lubricants

- Enerpac's Controlled Bolting Equipment including: Torque Multipliers, Hydraulic Wrenches and Bolt Tensioning tools

Custom Joint information can also be entered.

The software offers Tool selection, Bolt Load calculations and Tool pressure settings, as well as, a combined Application data sheet and Joint completion report.

Page: 416

HSQ Series



Maximum Torque at 10.000 psi:

1541 - 7562 Ft.lbs

Maximum Torque at 690 bar:

2089 - 10.252 Nm

Square Drive Range:

3/4 - 1 1/2 inch

Maximum Operating Pressure:

10.000 psi / 690 bar

TORQUE WRENCH SELECTION (based on socket size range)

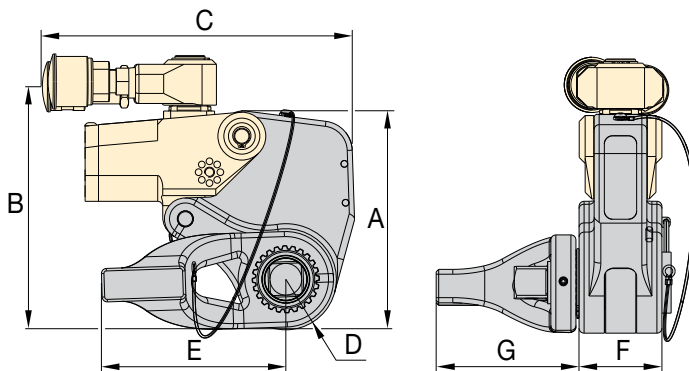
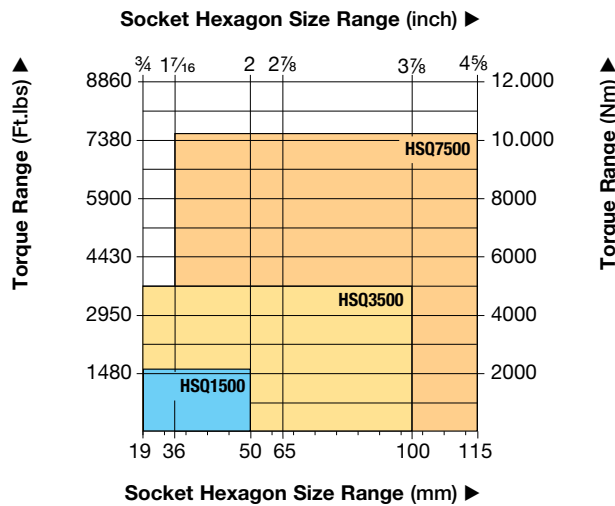

SELECTION CHART

Max. Torque Output		Square Drive Size (in)	Sq. Drive Cassette Model Number*	Dimensions (in)							Wt. (lbs)	Dimensions (mm)							Wt. (kg)
(ft-lbs)	(Nm)			A	B	C	D	E	F	G		A	B	C	D	E	F	G	
1541	2089	3/4	HSQ1500	5.71	6.61	6.85	1.19	2.36	1.95	3.29	8.16	145	168	174	30	60	50	84	3,7
3750	5084	1	HSQ3500	7.54	8.23	7.95	1.52	3.07	2.58	4.35	13.01	192	209	202	39	78	66	111	5,9
7562	10252	1 1/2	HSQ7500	9.60	10.08	9.25	1.99	4.33	3.23	6.32	25.13	244	256	235	51	110	82	161	11,4

* IMPORTANT: HMT-drive units must be ordered separately to operate the HSQ-Square Drive Cassettes.



BSH-Series Sockets

Heavy-Duty Impact Sockets for power driven torquing equipment.

Page: 244



Select the Right Torque

Choose your Enerpac Torque Wrench using the untightening rule of thumb: Loosening torque equals about 250% of tightening torque.



Torque Wrench Pumps

Visit enerpac.com for system matched air and electric torque wrench pumps that are ideal for use with hydraulic torque wrenches.

Page: 291

▼ Shown from left to right: E291, E393, E494



Accurate, Efficient Torque Multiplication

When accurate make-up or break-out of stubborn fasteners requires high torque

- High-efficiency planetary gear sets achieve high output torque from low input torque
- Most models operator protected by anti-backlash device
- Multiplier output accuracy $\pm 5\%$ of input torque
- Reversible, tighten or loosen bolts
- Reaction bar or reaction plate type
- Angle-of-turn protractor standard on E300 series models
- Reaction plate models offer increased versatility with reaction point locations
- E300 and E400 series replaceable shear drives provide overload protection of internal power train
- One replacement shear drive is included with each E300 and E400-Series models



Typical Torque Multiplier Applications

- Locomotives
- Power plants
- Pulp and paper mills
- Refineries
- Chemical plants
- Mining and construction
- Off-road equipment
- Shipyards
- Cranes



▼ SELECTION CHART

Torque Multiplier Type	Nominal Torque Output		Model Number
	(Ft.lbs)	(Nm)	
Reaction Bar Multiplier	750	1020	E290PLUS
	1000	1358	E291
	1200	1627	E391
	2200	2983	E392
	3200	4340	E393
Reaction Plate Multiplier	2200	2983	E492
	3200	4339	E493
	5000	67879	E494
	8000	10,846	E495



Manual Torque Multipliers

Enerpac manual torque multipliers provide efficient torque multiplication in wide clearance applications and when external power sources are not available.

Manual torque multipliers are used in most industrial, construction, and equipment maintenance applications. Hydraulic torque wrenches are better suited for tight tolerance, flange and repetitious bolting applications.

Use Reaction Bar Models:

- where space is limited
- where multiple reaction points are available
- when portability is desirable

Use Reaction Plate Models:

- above 3200 Ft.-lbs. output torque
- on flanges and applications where neighboring bolt or nut is available to react against
- when extreme reaction forces are generated

E Series



Nominal Output Torque:

750 - 8000 Ft.lbs

Torque Ratio:

3:1 - 52:1

Multiplier Output Ratio Accuracy:

± 5 %

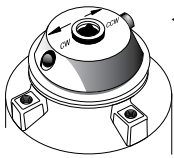

Selector Pawl

Models with anti-backlash protection have directional selector pawls. Set the pawl for clockwise or counter-clockwise rotation.

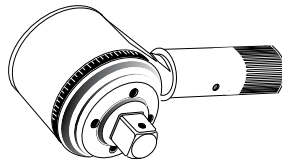

Angle-of-Turn Protractor

E391, E392 and E393 models include an angle-of-turn protractor (scale) to tighten fasteners using a "torque turn" method. Allows accurate measuring a specific number of degrees of rotation.

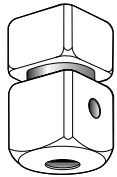

Shearable Square Drive

Designed to provide overload protection on E300- and E400-series multiplier power train by shearing when excess input torque is applied. Internal shear pin prevents tool from falling off bolt.



CAUTION!

Never use impact type air tools for power driving torque multipliers. Torque multiplier drive train damage will occur.

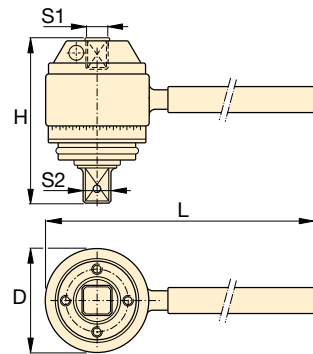

Reaction Bar Type ¹⁾

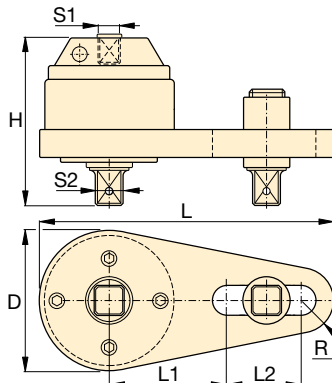

Reaction Plate Type ¹⁾



BSH-Series Sockets

Heavy-Duty Impact Sockets for power driven torquing equipment.

Page: 244



Back-Up Spanners

Hands free tool to be used to stop back nut from turning during make up or break out. Two hex sizes in one tool.

Page: 245

Input Torque		Torque Ratio (estimate)	Input Female Square Drive		Output Male Square Drive		Over-load Protection	Anti-Back-lash	Dimensions (in)						Wt. (lbs)	Model Number
(Ft.lbs)	(Nm)		S1 (in)	S2 (in)	Replaceable Shear Drive Model No.	D			H	L	L1	L2	R			
250	339	3 : 1	1/2	3/4	–	No	No	2.8	3.3	8.5	–	–	–	4.0	E290PLUS	
333	452	3 : 1	1/2	3/4	–	No	No	2.8	3.3	17.4	–	–	–	5.5	E291	
200	271	6 : 1	1/2	3/4	E391SDK	Yes	No	3.9	4.0	19.6	–	–	–	9.0	E391	
162	220	13.6 : 1	1/2	1	E392SDK	Yes	Yes	4.1	5.7	19.6	–	–	–	15.2	E392	
173	235	20.25 : 1	1/2	1	E393SDK	Yes	Yes	4.1	6.5	19.6	–	–	–	18.3	E393	
162	219	13.6 : 1	1/2	1	E392SDK	Yes	Yes	4.9	5.5	14.0	5.5	4.9	1.3	17.2	E492	
173	234	18.5 : 1	1/2	1	E393SDK	Yes	Yes	4.9	6.4	14.0	5.5	4.9	1.3	19.6	E493	
189	256	26.5 : 1	1/2	1 1/2	E494SDK	Yes	Yes	5.6	8.7	14.9	7.0	3.5	1.7	34.0	E494	
208	154	52 : 1	1/2	1 1/2	E495SDK	Yes	Yes	5.8	10.7	15.2	7.0	3.5	1.9	50.3	E495	

¹⁾ E200 and E400-series do not have an Angle-of-Turn Protractor (scale).

User must verify manual torque wrench accuracy prior to use to ensure accurate final output torque.

▼ PTW1000



Continuous Rotation Controlled Torque

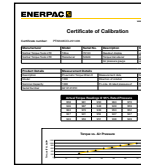

Calibration Certificate

All PTW tools are CE declared and are shipped complete with a calibration certificate.



FRL120C, Filter-Regulator-Lubricator with Air Hose

All PTW-Series tools are shipped complete with standard reaction arm, and Filter-Regulator-Lubricator (FRL120C).



MCS-Series, Mobile Calibration System

To check torque accuracy, run calibration tests and create calibration certificates prior to the use of continuous rotation torque tools in various applications while on a job site.

Page: 290

Productivity

- High speed continuous rotation for constant torque output
- Low friction planetary gearbox design minimizes wear and extends uptime

Safety

- Ergonomic, low vibration design reduces fatigue and the risk of vibration related injuries for the operator
- Low noise air motor provides quiet, consistent performance for indoor and outdoor applications

Convenience

- Provided with standard reaction arm; wide assortment of custom arms and accessories are available
- Available with or without Filter-Regulator-Lubricator (FRL)
- Unique calibration certificate provided with each tool

▼ PTW-Series Pneumatic Torque Wrenches are ideal for applications where speed and precision are critical, such as track maintenance.



◀ The PTW1000 makes quick work of this flange maintenance job.



Pneumatic Torque Wrenches



PTW-Series Pneumatic Torque Wrenches

Enerpac PTW-Series Pneumatic Torque

Wrenches are designed for applications that require speed and control.

The standard package includes a Torque Wrench with a calibration certificate, an FRL (Filter/Regulator/Lubricator), and a 10 ft. (3 m) long, 1/2" (13 mm) diameter air hose, which connects the FRL to the wrench.

Once the air hoses are connected, the operator simply adjusts the air pressure on the FRL to achieve the

desired torque using the calibration certificate. After this, the tool is ready to go to work!*

The air source used with the PTW system must be regulated and/or limited to 120 psi (8.3 bar), and must be capable of providing a volume of at least 50 CFM (85 CMH) at 100 psi (6.9 bar). A separate 1/2" (13 mm) hose (not included) must be used to connect the FRL to the air supply.

*See instruction manual for comprehensive instructions

PTW Series



Nominal Output Torque:

6000 Ft.lbs

Square Drive Range:

3/4 - 1 - 1 1/2 inches

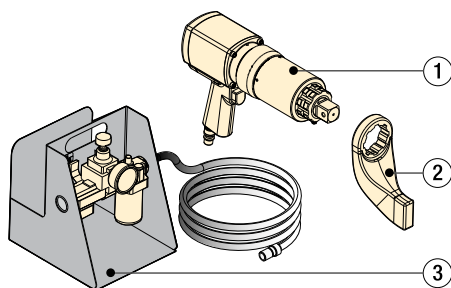

- ① PTW Torque Wrench
- ② Standard Reaction Arm
- ③ FRL120C Filter-Regulator-Lubricator with 10-foot air hose

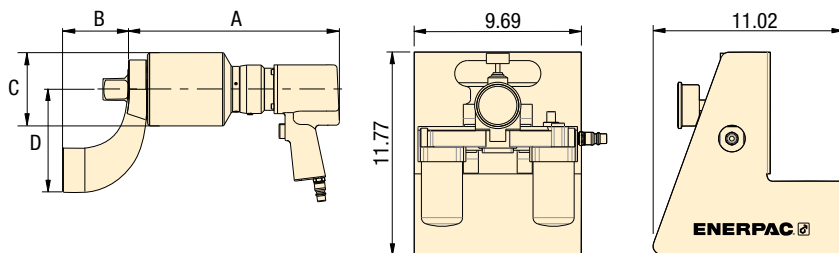

Accessories

Enerpac offers a full line of accessories including a range of reaction arms and drives.

Page: 288



BSH-Series Sockets

Heavy-Duty Impact Sockets for power driven torquing equipment.

Page: 244



Back-Up Spanner

Hands free tool to be used to stop back nut from turning during make up or break out. Two hex sizes in one tool.

Page: 245

▼ SELECTION CHART

All tools are shipped complete with standard reaction arm and FRL*.

Minimum Torque		Nominal Torque		Square Drive (in)	Model Number*	RPM	Dimensions (in)				Weight** (lbs)
(Ft.lbs)	(Nm)	(Ft.lbs)	(Nm)				A	B	C	D	
300	407	1000	1356	3/4	PTW1000-75C	12.6	10.70	3.27	2.83	5.12	17.4
300	407	1000	1356	1	PTW1000C	12.6	10.70	3.27	2.83	5.12	18
500	678	2000	2712	1	PTW2000C	8.0	11.26	3.27	3.11	5.24	19.5
900	1220	3000	4067	1	PTW3000C	3.1	13.50	3.27	3.74	5.24	23
1300	1763	6000	8135	1 1/2	PTW6000C	2.5	14.40	4.49	5.00	7.00	39

* To order without FRL and hose, remove "C" suffix from model number (e.g. PTW3000).

** Weight does not include reaction arm. Reaction arm weight for PTW1000, PTW2000, PTW3000 is 2.9 lbs. and for the PTW6000 is 7.75 lbs.

▼ Shown: Accessories for PTW-Series Torque Wrenches

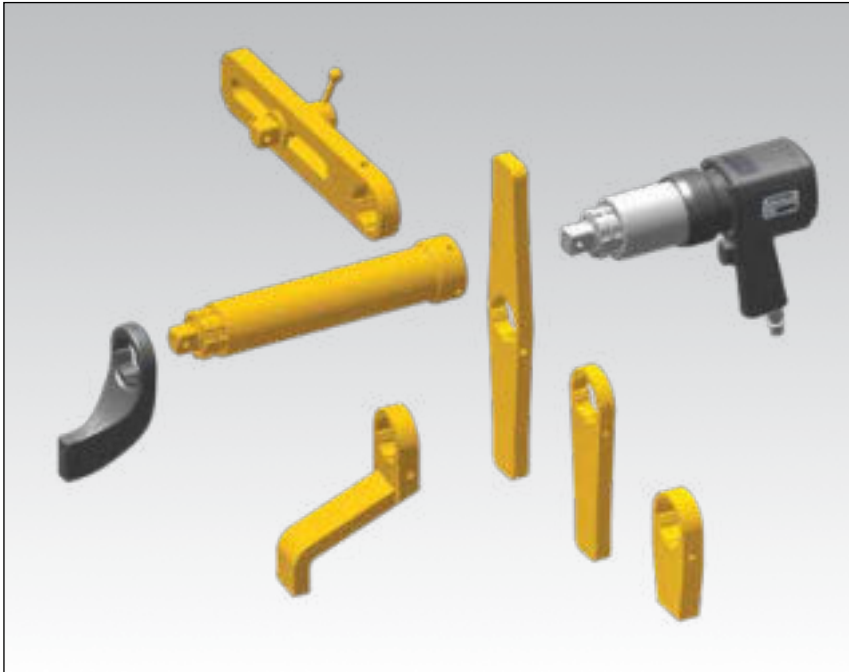

- **Accessories for further extending the application range of pneumatic torque wrenches**
- **Extended drives increase tool fit in restricted access areas**



PTW-Series Torque Wrenches

Enerpac offers the following accessories to support a wide variety of applications in industries such as mining, power generation and oil and gas. For additional custom accessories not pictured here, please contact Enerpac.



Applications

PTW-Series Pneumatic Wrenches are designed for applications that require speed and control.

Mining

- Track maintenance
- Undercarriage maintenance
- Wheel maintenance
- Shovel maintenance

Power Generation

- Turbine bolts
- Tower segments
- Turbine casings

Oil & Gas

- Pipe flanges
- Valves
- Manway covers
- Pressure vessels

▼ *Shovel and Track maintenance*



▼ *Wheel maintenance*



Torque Wrench Accessories for PTW-Series

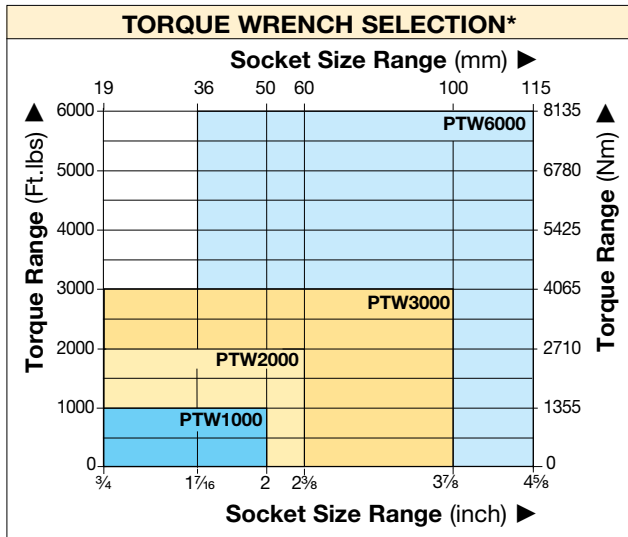

PTW Series



Nominal Output Torque:

6000 Ft.lbs

Square Drive Range:

3/4 - 1 - 1 1/2 inches



BSH-Series Sockets

Heavy-Duty Impact Sockets for power driven torquing equipment.

Page: 244

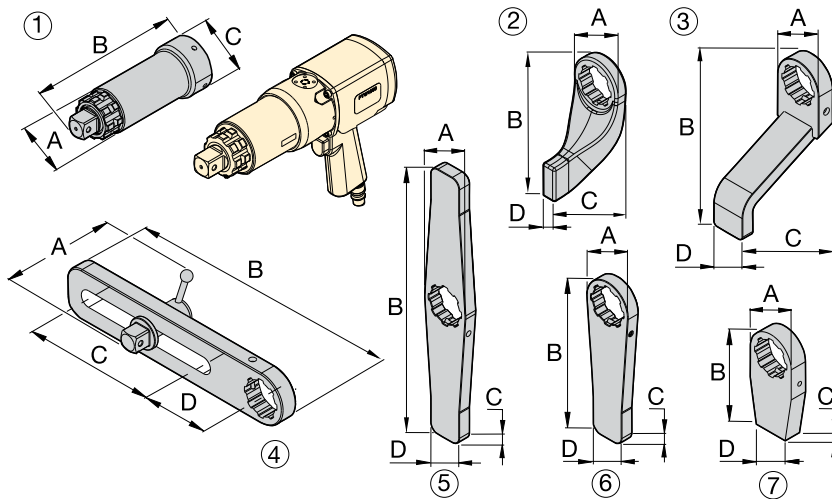

▼ Optional accessories for use with PTW1000, PTW2000, PTW3000 models							
No.	Description	Model No.	Application	Dimensions in inches			
				A	B	C	D
1	Extended Drive, 6 inch (152 mm)	ED6TWS	Nose extension, primarily for truck wheel bolts	2.44	8.11	2.87	—
1	Extended Drive, 12 inch (305 mm)	ED12TWS		2.44	15.12	2.87	—
1	Extended Drive, 18 inch (457 mm)	ED18TWS		2.44	20.12	2.87	—
2	Standard Reaction Arm	RATWS	Standard arm included with PTW model	2.99	6.77	4.02	0.83
3	Extended Reaction Arm	ERATWS	Long plate for use with deep well sockets	2.87	5.91	7.95	2.01
4	Sliding Reaction Arm	SLRATWS	For widely spaced and uneven bolt centers	4.41	15.00	7.99	4.02
5	Double Straight Reaction Arm	DSATWS	Reduces time to reposition arm *	2.87	15.98	0.75	4.02
6	Straight Reaction Arm	SRATWS	Long plate for wide spaced reaction points	2.87	9.45	0.75	2.01
7	Blank Reaction Arm **	BLTWS	Weldable blank for custom applications **	2.83	5.94	0.98	2.01
▼ For use with PTW6000							
1	Extended Drive 6 inch (152 mm)	ED6TWL	Nose extension, primarily for truck wheel bolts	3.31	9.13	4.02	—
1	Extended Drive 12 inch (305 mm)	ED12TWL		3.31	15.12	4.02	—
2	Standard Reaction Arm	RATWL	Standard arm included with PTW model	4.02	9.02	5.75	1.26
3	Extended Reaction Arm	ERATWL	Long plate for use with deep well sockets	4.02	10.00	7.24	2.52
4	Sliding Reaction Arm	SLRATWL	For widely spaced and uneven bolt centers	5.98	16.50	7.48	4.49
5	Double Straight Arm	DSATWL	Reduces time to reposition arm *	4.02	20.00	1.26	2.24
6	Straight Reaction Arm	SRATWL	Long plate for wide spaced reaction points	4.02	12.01	1.26	2.24
7	Blank Reaction Arm **	BLTWL	Weldable blank for custom applications **	4.02	5.98	1.26	2.24

* Time to reposition arm when repeatedly moving from tightening to loosening.

** ⚠ WARNING: Blank reaction arms must be heat-treated to HRC 38-42 prior to use.

▼ MCS7500C, Mobile Calibration System



MCS Series

Nominal Output Torque:

148 - 7375 Ft.lbs

Square Drive Range:

1½ inches



Accuracy

The calibration system is a calibrated instrument qualified in a UKAS certified laboratory. The accuracy of the MCS7500C is calibrated to meet or exceed: 1% of FSD from 2% to 8% of torque range and 1% of reading from 8% to 100% of torque range.

Versatility

- Accurately measures torque output for continuous rotation tools and hydraulic (*) square drive torque wrenches from 148-7375 Ft.lbs (200-10,000 Nm)
- Adaptable design enables use with a large variety of Enerpac and competitive wrenches
- Internal Li-ion battery pack, external power via 5V DC USB power supply

Performance

- Certificate Manager feature enables quick and easy creation of calibration certificates
- Tool database feature allows specific wrench data and calibration results to be recorded and saved for future use
- Each MCS comes with a standard ISO17025 calibration certificate

Ease of Use

- Compact design facilitates easy transport, allowing calibration to be carried out in the shop, on jobsites, or even in a vehicle
- Integrated digital interface enables torque values to be displayed, saved, printed or transferred to a computer

* Additional Reaction Block and appropriate Adaptor is required with the use of S- and RSL-Series square drive hydraulic wrenches



Female Reducer Set

The Female Reducer Set consists of two reducers: 1½ x 1 inch and 1½ x ¾ inch. To be ordered separately as **MCS7500RS**.



Additional Reaction Block and Adaptor

A heavy-duty adjustable reaction block in combination with one of the three adaptors is required to facilitate the use with S- and RSL-Series Square Drive Wrenches as well as most competitive hydraulic wrenches to maximum 7375 Ft.lbs (10,000 Nm).

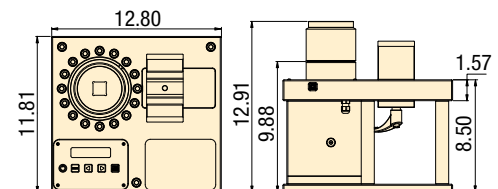



























▼ SELECTION CHART

Minimum Measurable Torque Output		Nominal Measurable Torque Output		Female Square Drive	Model Number**	Description	Weight
(Ft.lbs)	(Nm)	(Ft.lbs)	(Nm)				
148	200	7375	10,000	1½	MCS7500C	MCS with carrying case	87

** Not suitable for use with impact tools or low-profile torque wrenches.

Selection Matrix – Optimum Wrench-Pump Combinations

For optimum speed and performance Enerpac recommends the following system set-up with wrench-pump-hose combinations. For other combinations, consult your Enerpac bolting expert or your authorized Enerpac distributor.

		ELECTRIC PUMPS					AIR DRIVEN PUMPS	
		Cordless XC-Series	E-Pulse® E-Series	TQ-Series	ZU4T-Series	ZE-T-Series	LAT-Series	ZA4T-Series
								
Speed:								
Oil Flow at 10,000 psi:		15 in ³ /min	32 in ³ /min	30 in ³ /min	60 in ³ /min	60-120 in ³ /min	25 in ³ /min	60 in ³ /min
Reservoir Capacity:		0.5 gallon	0.8 gallon	1 gallon	1.2 - 1.8 gal.	1.2 - 5.2 gal.	0.8 gal.	1.2 - 1.8 gal.
Duty Cycle:		Intermittent	Heavy-Duty	Standard	Heavy-Duty	Heavy-Duty	Standard	Heavy-Duty
Weight:								
Field/Factory Work:		Field/Factory	Field/Factory	Field/Factory	Field	Factory	Field	Field
	S1500X	Optimal	Optimal	Optimal	Optimal	Optimal	Optimal	Optimal
	S3000X							
	S6000X	-	Acceptable	Acceptable				
	S11000X							
	S25000X							
	W2000X	Optimal	Optimal	Optimal				
	W4000X							
	W8000X	-	Acceptable	Acceptable				
	W15000X							
	W22000X							
W35000X								
	RSL 1500	Optimal	Optimal	Optimal	Optimal	Optimal	Optimal	Optimal
	RSL3000							
	RSL5000	-	Acceptable	Acceptable				
	RSL8000							
	RSL11000							
	RSL19000							
	RSL28000							
	DSX1500	Optimal	Optimal	Optimal	Optimal	Optimal	Optimal	Optimal
	DSX3000							
	DSX5000	-	Acceptable	Acceptable				
	DSX11000							
	DSX25000							
	HMT 1500	Optimal	Optimal	Optimal	Optimal	Optimal	Optimal	Optimal
	HMT3500							
	HMT7500	Acceptable	Acceptable	Acceptable				
	HMT13000	-						



XC-Series, Portable Cordless Pumps

The XC battery torque wrench pump is ideal for maintenance bolting applications at sites that do not have access to power or where having extension cords or air hoses could cause trip hazards.

E-Series, E-Pulse Electric Torque Wrench Pumps

Ideal for high volume fastening applications where weight is critical. Features an interactive pendant for operation, programming and diagnostics.

TQ700 Series Electric Torque Wrench Pumps

Designed for both portability and production to deliver superior bolting speed.

ZU4T Electric Torque Wrench Pumps

Works well with long extension cords or generator driven electrical power supplies. Available in **Pro** and **Classic** formats.

ZU4T Pro Pumps have an LCD feature to display torque or pressure, selectable torque wrench, and self-diagnostics.

ZU4T Classic Pumps feature an analog gauge and a basic electrical package to deliver durable, safe and efficient hydraulic power.

ZE-T-Series Electric Torque Wrench Pumps

Features LCD to display torque or pressure values, and self-diagnostics. With induction motor, making the ZE-Series the coolest and quietest pumps in their class.

LAT-Series Lightweight Torque Air Pumps

Combines compact design and high productivity for bolting applications in areas hard to access with larger air powered pumps.

ZA4T-Series, Air Driven Torque Wrench Pumps

This air driven pump is best suited to power medium to large size torque wrenches.

THQ-Series, Torque Wrench Hoses

Use Enerpac THQ700-Series twin hoses with all torque wrenches to ensure the integrity of your hydraulic system.

▼ XC1502TB



Portable Battery Pump for Torque Applications

- Ideal for maintenance bolting applications requiring portability and convenience
- Interactive pendant provides visual and vibratory feedback of pump operation
- User can set pressure and operate in manual or auto-cycle mode
- Superior run-time with 5Ah, 28V battery
- Brushless DC motor extends motor life and reduces maintenance
- 20-foot detachable pendant control, with option to use trigger control as well
- 4-inch glycerin-filled gauge for easy viewing
- User-adjustable relief valve can be locked when desired pressure is set

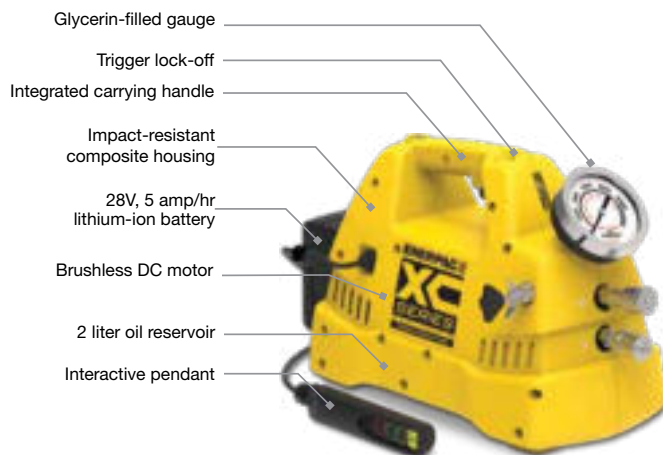

28-Volt Battery

The **XC28V5** with Lithium-Ion technology for maximum battery performance.



Battery Charger

1-hour quick charger.

XC115VC	115 VAC
XC230VC	230 VAC



Roll Cage

A roll cage accessory is available for all XC models. Please order model number **XCRCTK**.



Torque Wrenches

The following wrenches are ideal for use with the XC Cordless Torque Wrench Pump:

Torque Wrench Series

S	W	RSL	DSX	HMT
S1500X	W2000X	RSL1500	DSX1500	HMT1500
S3000X	W4000X	RSL3000	DSX3000	HMT3500
		RSL5000		HMT7500

Larger wrenches will work with the pump, battery run time and application speed will be impacted.

Cordless Torque Pumps



The XC-Series Cordless Torque Wrench pump is ideal for maintenance applications in the PowerGen, Oil & Gas and MRO markets. This portable pump is perfect for remote locations, sites that do not have access to power or where trip hazards are a concern.

The interactive pendant allows the user to set and clear pressure and operate in manual or auto-cycle mode.

The pump has an easily accessible user adjustable valve for precise pressure control.

Fasteners Torqued On One Charge

Torque Wrench	Nut AF (in)	Stud (in)	Pressure (psi)	Torque (ft-lbs)	Fasteners Torqued
S3000X	2 3/8"	1 1/2"	4800	1500	32
W2000X	2 3/8"	1 1/2"	5000	1000	52

XC Series



Useable Oil Capacity:

120 in³

Flow at Rated Pressure:

15 in³/minute

Motor Size:

0.5 hp

Maximum Operating Pressure:

10,000 psi

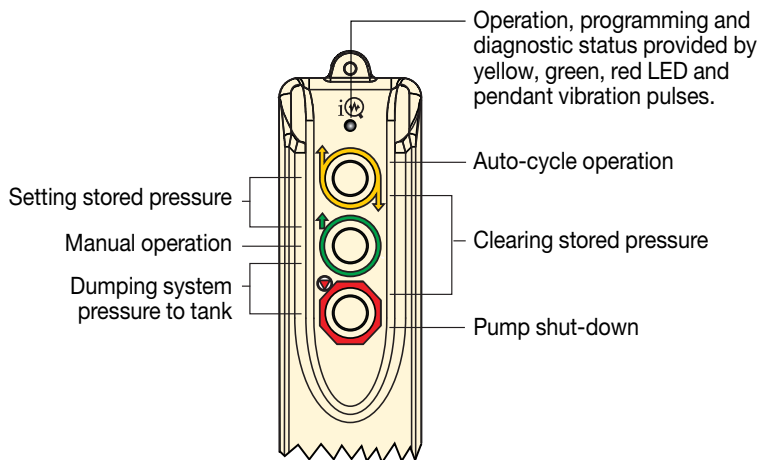

Twin Torque Wrench Hoses

Use Enerpac THQ700 series twin hoses with 10,000 psi torque pumps.

6 feet long, 2 hoses	THQ702T
19.5 feet long, 2 hoses	THQ706T
39 feet long, 2 hoses	THQ712T

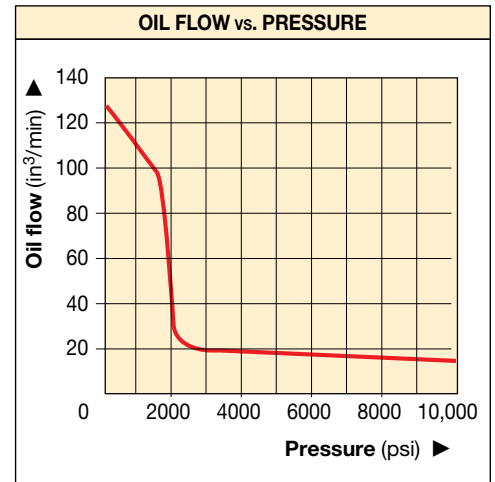
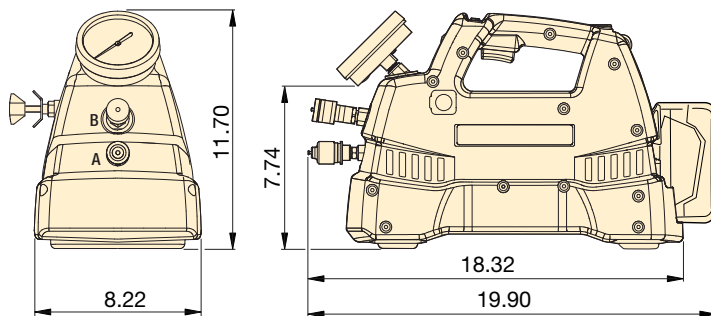

Pump Type	Useable Oil Capacity (in ³)	Model Number	Output Flow Rate (in ³ /min)			Included with Pump	Weight (includes oil) (lbs)
			No Load	2000 psi	10,000 psi		
Cordless Pump Kit	120	XC1502TB	125	30	15	2 batteries and 115V charger	29.0
Cordless Pump Kit	120	XC1502TE	125	30	15	2 batteries and 230V charger	29.0
Cordless Pump	120	XC1502T*	125	30	15	No batteries or charger	26.6

* Batteries and charger not included.

▼ EP3504TB E-Pulse Torque Wrench Pump



Productivity through innovation



Bolting Integrity Software

Enerpac Bolting Integrity Software Solutions play a key role in implementing and managing an Integrity Program for bolted connections. The software offers Tool selection, Bolt Load calculations and Tool pressure settings, as well as, a combined Application Data Sheet and Joint Completion Report. Custom Joint information can also be entered.

Page: 416

Performance

- Two-stage pump with high by-pass pressure: 60 in³/min at 3000 psi, 32 in³/min at 10,000 psi
- Smart controls enable motor to maintain constant power across the pressure range
- 24V DC power regulator minimizes effects of poor power supply
- Six-piston block design provides even flow for smooth operation of tool

Durability

- High-efficiency permanent magnet, direct drive motor enables continuous use and long service life
- Built-in thermal protection
- System components enclosed for protection
- IP Rating: IP54 on the Pump, IP67 on the Pendant
- Integrated heat exchanger minimizes heat buildup

Convenience

- Integrated calibrated pressure gauge
- Pendant and cord management system
- Draining oil not required for pump element maintenance
- Convenient oil fill port, oil level indicator and automatic breather



Torque Wrenches

The following wrenches are ideal for use with the XC Cordless Torque Wrench Pump:

Torque Wrench Series

S	W	RSL	DSX	HMT
S1500X	W2000X	RSL1500	DSX1500	HMT1500
S3000X	W4000X	RSL3000	DSX3000	HMT3500
		RSL5000	DSX5000	HMT7500

Larger wrenches will work with the pump, battery run time and application speed will be impacted.

Page: 239



THQ Series Torque Wrench Hoses

Use Enerpac THQ700 series twin hoses with 10,000 psi torque wrenches and torque pumps.

10,000 psi	
6 feet long, 2 hoses	THQ702T
19.5 feet long, 2 hoses	THQ706T
39 feet long, 2 hoses	THQ712T

E-Pulse® Electric Torque Pumps



E-Pulse Torque Wrench Pump

The Enerpac E-Pulse Torque Wrench Pump, through its innovative design, is ideal for high volume fastening applications where weight is a critical factor. Smart controls enable the motor to maintain constant power providing higher flow than "traditional" ½ hp pumps.

The durable aluminum housing, integrated heat exchanger and highly efficient permanent magnet motor minimize heat buildup in the toughest environments. The interactive pendant provides the operator a number of usage options for optimal efficiency. The E-Pulse Torque Wrench Pump is the pinnacle of bolting equipment.



- Setting stored pressure
- Manual operation
- Dumping system pressure to tank
- Intelligent Auto-cycle
- Clearing stored pressure
- Pump shut-down

Torque Wrench
20-ft. cord

Interactive Torque Wrench Pendant

- User can set pressure and operate in manual or auto-cycle mode
- Intelligent Auto-Cycle enables press and release actuation to cycle wrench until final torque is achieved

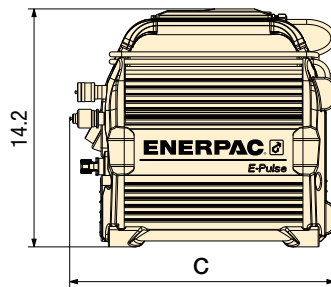
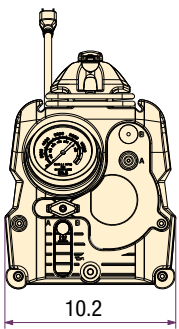

E-Pulse torque pump used for high volume fastening applications.

E Series



Useable Reservoir Capacity:

0.8 gallon

Flow at Rated Pressure:

32 in³/minute

Motor Size:

0.85 hp

Maximum Operating Pressure:

10,000 psi

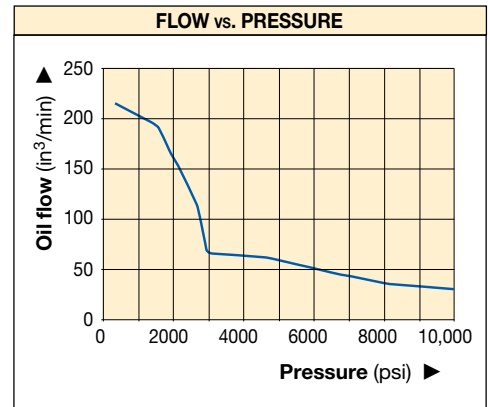

Number of Wrenches Pump can Operate	Useable Oil Capacity (gal)	Model Number	Output Flow Rate (in ³ /min)				Motor Voltage (VAC)	Plug Type	Current Draw (Amps)	Sound Level (dBA)	Dimension C (in)	Weight (with oil) (lbs)
			14.5 psi	2538 psi	5075 psi	10,000 psi						
1	0.8	EP3504TB	220	130	58	32	100-120	NEMA 5-15	12	70-85	15.8	44.9
		EP3504TI	220	130	58	32	200-250	NEMA 6-15	7	70-85	15.8	44.9
		EP3504TE	220	130	58	32	200-250	Schuko CEE 7/7	7	70-85	15.8	44.9
2	0.8	EP3504TB-M*	220	130	58	32	100-120	NEMA 5-15	12	70-85	16.9	47.9
		EP3504TI-M*	220	130	58	32	200-250	NEMA 6-15	7	70-85	16.9	47.9
		EP3504TE-M*	220	130	58	32	200-250	Schuko CEE 7/7	7	70-85	16.9	47.9

* Pump model with multi-port manifold.

▼ TQ700B



- Optimized flow technology delivers up to 50% faster bolting than competing pumps
- Compact and lightweight design fits through tight openings and provides easy handling
- Built-in protection for controls, gauge, and pendant for job-site durability
- IP55 rating for superior dust and water protection
- Advanced brushless motor provides for quiet, continuous operation, high voltage tolerance, and low maintenance
- Heat exchanger prevents breakdown of oil during heavy usage in hot environments
- Simple pressure setting and convenient pendant control for hassle-free operation

▼ The TQ700B and the W-Series wrenches are a productive combination in wind applications.



Lightweight Electric Torque Wrench Pump



Hydraulic Torque Wrenches

Enerpac offers a complete range of square drive and hexagon cassette torque wrenches.

Page: 239



Pendant Control

The TQ700 comes equipped with a 20-foot pendant cord which allows the user to pressurize the pump from a distance increasing productivity and speed of setup.



Four-Port Manifold

The TQ700 offers an optional four wrench manifold as an accessory (TQM) factory installed. (Add suffix "M" at the end of the model number. For example: TQ700EM)



Twin Torque Wrench Hoses

Use Enerpac THQ-Series twin hoses with 10,000 psi torque wrenches and

torque pumps.

10,000 psi	
6.5 feet long, 2 hoses	THQ702T
19.5 feet long, 2 hoses	THQ706T
39 feet long, 2 hoses	THQ712T



Gauge Overlay Kit

Gauge overlay kits are also available separately.

GT4015Q includes overlays for all S-, W-, RSL-, DSX and HMT-Series Torque Wrenches.

Electric Torque Pumps



TQ700 Series Pump Applications

The TQ700 Series pump is ideal for powering hydraulic wrenches for the Power Generation and Wind Markets.

Bolting speed is more complex than how much flow per minute the pump produces. The key is optimizing the flow rate across the entire bolting cycle. With more oil flowing at the right time and at the right volume, you achieve the optimized flow for a hydraulic bolting system.

The result of this optimized flow is more bolts tightened faster and a more productive work team.

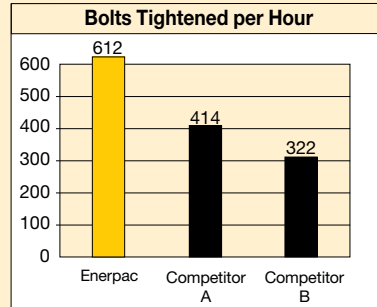

Internal laboratory testing based on standard torquing procedure on a pipe flange with 14, 1 1/8" bolts.

TQ Series



Reservoir Capacity:

1 gallon

Flow at Rated Pressure:

30 in³/minute

Maximum Operating Pressure:

10,000 psi



IP55 Rating for Superior Dust and Water Protection

The IP Code (or Ingress Protection Rating) classifies

and rates the degrees of protection provided against the intrusion of solid objects and water in mechanical casings and electrical enclosures.

An IP55 rating means the TQ700 offers complete protection against contact with mechanical and electrical components, and that dust will not enter in a sufficient quantity to interfere with the operation of the equipment.

The IP55 rating also means water jets sprayed against the TQ700 from any direction will not have any harmful effects.

Dimensions shown in inches.

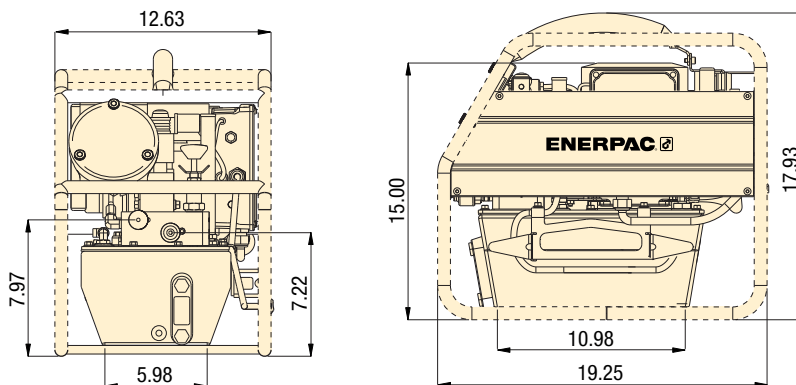

SELECTION CHART

For Use with Torque Wrenches	Pressure Rating (psi)	Model Number ¹⁾	Useable Oil Capacity (gal)	Motor Size (hp)	Motor Electrical Specifications (Volt - Ph - Hz)	Sound Level (dBA)	Wt. (lbs)
All S, W, RSL, DSX & HMT-Series wrenches	10,000	TQ700B	1	1.0	115 - 1 - 50/60	82 - 85	68
	10,000	TQ700E ²⁾	1	1.0	230 - 1 - 50	82 - 85	66
	10,000	TQ701 ³⁾	1	1.0	230 - 1 - 60	82 - 85	66

1) All models meet CE safety requirements and all TÜV requirements

2) European plug and CE EMC directive compliant

3) With NEMA 6-15 plug

▼ The TQ700B and the W-Series wrenches are a productive combination.



▼ ZU4204TB-Q (Pro-Series) and ZU4204BB-Q (Classic)



Z Tough.
Dependable.
Innovative.
CLASSIC

- Features Z-Class high-efficiency pump design; higher oil flow and bypass pressure, cooler running and requires 18% less current draw than comparable pumps
- Powerful 1.7 hp universal electric motor provides high power-to-weight ratio and excellent low-voltage operating characteristics
- High-strength, molded composite shroud protects motor and electrical components, while providing an ergonomic, non-conductive handle for easy transport
- Low-voltage pendant provides additional safety for the operator
- Relief valve adjustment range 1800 - 10,000 psi

Pro-Series

- LCD readout provides pressure and torque display and a number of diagnostic and readout capabilities never before offered on a portable electric pump
- Auto cycle feature provides continuous cycle operation of the torque wrench as long as the advance button is pressed. (Pump can be used with or without auto cycle feature)



Back-lit LCD Display for Pro Series

Back-lit LCD and Pressure Transducer featuring Auto-Cycle Technology.

- Digital read-out and "Autocycle" setting
- "Auto-Cycle" setting easily programmable
- Torque wrench model is selectable
- Pump usage information, hour and cycle counts
- Low-voltage warning and recording
- Self-test and diagnostic capabilities
- Information can be displayed in English, French, German, Italian, Spanish and Portuguese
- Pressure transducer is more accurate and durable than analog gauges
- Easy-viewing variable rate display
- Display pressure in bar, MPa or psi



◀ Any brand of hydraulic torque wrench can be powered by the portable ZU4T-Series torque wrench pump.



Z-Class – A Pump For Every Application

Patented Z-Class pump technology provides high by-pass pressures for increased productivity—important in applications using long hose runs and high pressure-drop circuits, like heavy lifting or certain double-acting tools.

Enerpac ZU4T Hydraulic Pumps are built to power small to large torque wrenches.

Classic Electric Torque Wrench Pump

- The Classic has an analog gauge and traditional electro-mechanical components (transformers, relays and switches) in place of solid-state electronics.

The Classic delivers durable, safe and efficient hydraulic power.

Pro Series Electric Torque Wrench Pump

- Digital (LCD) display features a built-in hour meter, pressure and torque display, and shows self-diagnostic, cycle-count and low voltage warning information.
- AutoCycle feature provides continuous cycle operation of the torque wrench as long as the advance button is pressed. (Pump can be used with or without AutoCycle feature).

ZU4T Series



Reservoir Capacity:

1.2 and 1.8 gallons

Flow at 10,000 psi:

60 in³/minute

Motor Size:

1.7 hp

Maximum Operating Pressure:

10,000 psi



Overlay Kit with Gauge

Available separately for use with ZU4T-Series Classic: **GT4015Q** includes gauge and torque overlays for all

S-, W-, RSL-, DSX- and HMT-Series torque wrenches.

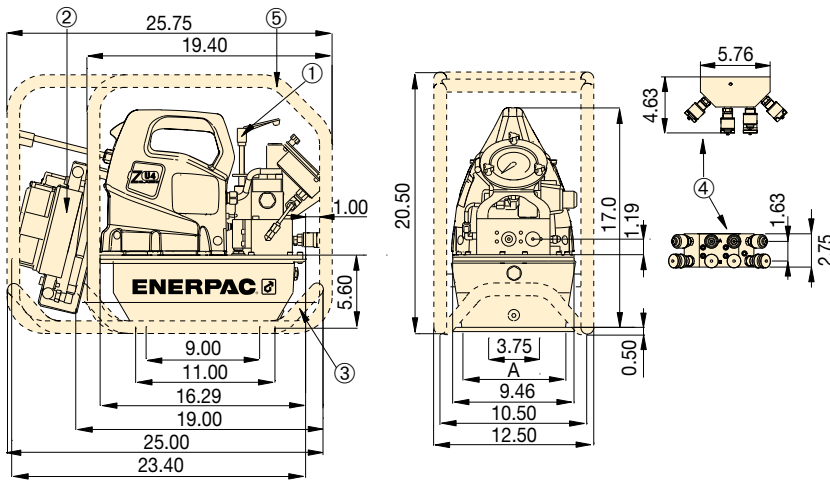

ZU4T-Series Torque Wrench Pumps

Reservoir Capacity (gallons)	A (in)
1.2	6.0
1.8	8.1

Dimensions shown in inches

- ① User adjustable relief valve
- ② Heat exchanger
- ③ Skidbar
- ④ 4-wrench manifold
- ⑤ Roll cage

ZU4T-Series Torque Pumps

ZU4T-Series Performance Chart							
Motor Size (hp)	Output Flow Rate (in ³ /min)				Motor Electrical Specification (Volt - Phase - Hz)	Sound Level (dBA)	Relief Valve Adjustment Range (psi)
	100 psi	700 psi	5,000 psi	10,000 psi			
1.7	700	535	76	60	115 - 1 - 50/60 208-240 - 1 - 50/60	85-90	1800 - 10,000



Bolting Integrity Software

Enerpac Bolting Integrity Software Solutions play a key role in implementing and managing an Integrity Program for bolted connections. The software offers Tool selection, Bolt Load calculations and Tool pressure settings, as well as, a combined Application Data Sheet and Joint Completion Report. Custom Joint information can also be entered.

Page: 416

OIL FLOW AND CURRENT vs PRESSURE

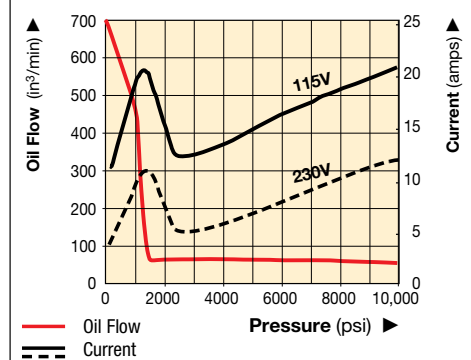

▼ Select a pump from the model matrix at the bottom of the page.

The functionality of the pump can be determined by the model number. Utilize the guide below to select the best pump for the application.

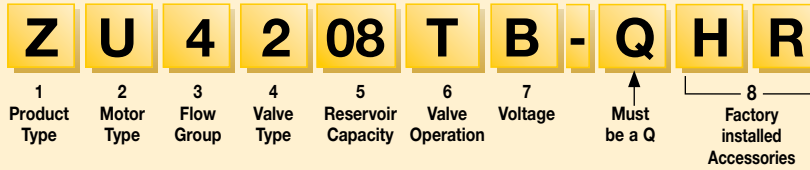

1 Product Type

Z = Pump series

2 Motor Type

U = Universal motor

3 Flow Group

4 = 60 in³/min @ 10,000 psi

4 Valve Type

2 = Torque wrench valve

5 Reservoir Capacity

04 = 1.2 gallons

08 = 1.8 gallons

6 Valve Operation

T = Solenoid valve with pendant, LCD electric and pressure transducer

B = Solenoid valve with pendant, classic electrical

7 Voltage

B = 115V, 1 ph, 50/60 Hz

E = 208-240V, 1 ph, 50/60 Hz (with European plug CE RF compliant)

I = 208-240V, 1 ph, 50/60 Hz (with NEMA 6-15 plug)

8 Factory Installed Accessories

H = Heat exchanger

K = Skid Bar

M = 4-wrench manifold

R = Roll cage



Torque Wrench Hoses

Use Enerpac twin safety hoses to connect your torque wrench to the pump.

10,000 psi	
6.5 feet long, 2 hoses	THQ702T
19.5 feet long, 2 hoses	THQ706T
39 feet long, 2 hoses	THQ712T



Torque Wrench Pump Selection Matrix

For optimum speed and performance see the torque wrench pump selection matrix.

Page: **291**

▼ Most hydraulic torque wrenches can be powered by the Enerpac ZU4T-Series torque wrench pump.



▼ ZU4T-SERIES CLASSIC PUMP MODELS

ZU4T Classic Model Numbers	Reservoir Capacity (gal)	Factory Installed Accessories				Wt. w/oil (lbs)
		Heat Exchanger	Roll Cage	Skid Bar	4-Wrench Manifold	
ZU4204BB-Q (I, E)	1.2					71.5
ZU4208BB-Q (I, E)	1.8					77.5
ZU4204BB-QH (I, E)	1.2	●				88
ZU4208BB-QH (I, E)	1.8	●				87
ZU4204BB-QR (E)	1.2		●			81
ZU4208BB-QR (E)	1.8		●			87
ZU4204BB-QHR (E)	1.2	●	●			90
ZU4208BB-QHR (I, E)	1.8	●	●			96
ZU4208BB-QHK (I, E)	1.8	●		●		92.5
ZU4208BB-QHM (I, E)	1.8	●			●	92
ZU4208BB-QMR (E)	1.8		●		●	93
ZU4208BB-QHMR (I, E)	1.8	●	●		●	102

▼ ZU4T-SERIES PRO PUMP (LCD) MODELS

ZU4T PRO Model Numbers	Reservoir Capacity (gal)	Factory Installed Accessories				Wt. w/oil (lbs)
		Heat Exchanger	Roll Cage	Skid Bar	4-Wrench Manifold	
ZU4204TB-Q (I, E)	1.2					68.5
ZU4208TB-Q (I, E)	1.8					74.5
ZU4204TB-QH (I, E)	1.2	●				78
ZU4208TB-QH (I, E)	1.8	●				84
ZU4204TB-QR (E)	1.2		●			78
ZU4208TB-QR (E)	1.8		●			84
ZU4204TB-QHR (E)	1.2	●	●			87
ZU4208TB-QHR (I, E)	1.8	●	●			93
ZU4208TB-QHK (I, E)	1.8	●			●	89.5
ZU4208TB-QHM (I, E)	1.8	●			●	89
ZU4208TB-QMR (E)	1.8		●		●	90
ZU4208TB-QHMR (I, E)	1.8	●	●		●	99

Torque Pump Accessories



4-Wrench Manifold

- For simultaneous operation of multiple torque wrenches

Accessory Kit No.	Can be used on ZU4T-Series torque wrench pumps
ZTM-Q ¹⁾	for 10,000-psi torque wrenches

¹⁾ For 4-Wrench Manifold add 6 lbs to pump weight



Skidbar

- Provides greater pump stability on soft or uneven surfaces
- Provides easy two-handed lift

Accessory Kit No.	Can be used on ZU4T-Series torque wrench pumps
SBZ-4	1.2 and 1.8 gallon ¹⁾
SBZ-4L	1.2 and 1.8 gallon ²⁾

¹⁾ Without heat exchanger 5 lbs.

²⁾ With heat exchanger 5.5 lbs.

ZU4T Series



Reservoir Capacity:

1.2 and 1.8 gallons

Flow at 10,000 psi:

60 in³/minute

Motor Size:

1.7 hp

Maximum Operating Pressure:

10,000 psi



Roll Cage

- Protects pump
- Provides greater pump stability

Accessory Kit No. ³⁾	Can be used on ZU4T-Series torque wrench pumps
ZRC-04	1.2 and 1.8 gallon reservoir ¹⁾
ZRC-04H	1.2 and 1.8 gallon reservoir ²⁾

¹⁾ For use with pumps without a heat exchanger fitted

²⁾ For use with pumps with a heat exchanger fitted

³⁾ For Roll Cage add 9.5 lbs to pump weight

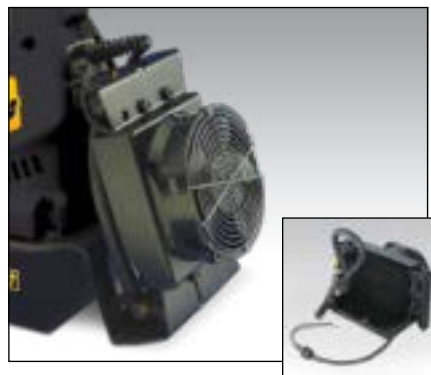

Heat Exchanger

- Removes heat from the bypass oil to provide cooler operation
- Stabilizes oil viscosity, increasing oil life and reduces wear of pump and other hydraulic components

Accessory Kit No.	Can be used with:
ZHE-U115	115V pumps
ZHE-U230	230V pumps

Heat Exchanger adds 9 lbs. to pump weight.

Thermal Transfer *	Maximum pressure	Maximum oil flow	Voltage
Btu/h	(psi)	(GPM)	(VDC)
900	300	7.0	12

* At 116 in³/min at 70° F ambient temperature. Do not exceed maximum oil flow and pressure ratings. Heat exchanger is not suitable for water-glycol or high water-based fluids.

▼ ZE4204TB-QHR



Z Tough.
Dependable.
Innovative.
CLASSIC



Back-lit LCD Display

- Digital pressure or torque read-out
- Programmable "Auto-Cycle" setting
- "Auto-Cycle" setting easily programmable
- Torque wrench model is selectable
- Display torque in Nm or Ft.lbs
- Pump usage information, hour and cycle counts
- Low-voltage warning and recording
- Self-test and diagnostic capabilities
- Information can be displayed in English, French, German, Italian, Spanish and Portuguese
- Pressure transducer is more accurate and durable than analog gauges

- **Auto-Cycle feature provides continuous cycle operation of the torque wrench as long as the advance button is pressed (Pump can be used with or without Auto-Cycle feature)**
- **LCD readout provides pressure and torque display and a number of diagnostic and readout capabilities never before offered on a portable electric pump**
- **Totally enclosed, fan-cooled industrial electric motors supply extended life and stand up to harsh industrial environments**
- **High-strength, molded electrical enclosure protects electronics, power supplies and LCD readout from harsh environments**



Bolting Integrity Software

Enerpac Bolting Integrity Software Solutions play a key role in implementing and managing an Integrity Program for bolted connections. The software offers Tool selection, Bolt Load calculations and Tool pressure settings, as well as, a combined Application Data Sheet and Joint Completion Report. Custom Joint information can also be entered.



◀ The ZE4T torque wrench pumps are perfectly matched for this W2000X wrench.

Electric Torque Pumps

ZE4T and ZE5T Oil Flow and Current vs. Pressure

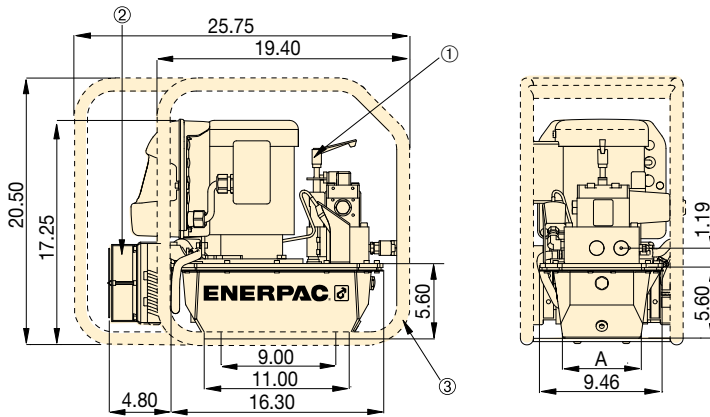
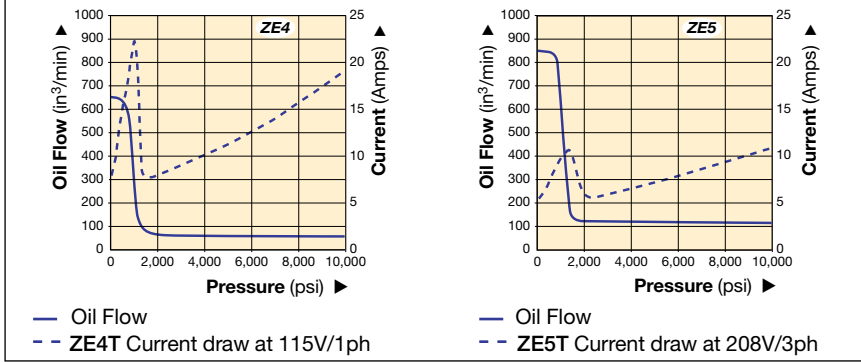

Reservoir Capacity (gallons)	A (in)	B (in)
1.2	6.0	13
1.8	8.1	13
5.2	16.6	19.2

Dimensions shown in inches.
 ① User adjustable relief valve
 ② Heat exchanger
 ③ Roll cage

▼ PERFORMANCE CHART

Pump Series	Output Flow Rate (in ³ /min)				Motor Size		Relief Valve Adjustment Range (psi)	Sound Level (dBA)
	100 psi	700 psi	5,000 psi	10,000 psi	hp	RPM		
ZE4T	650	600	62	60	1.5	1750	1000 - 10,000	75
ZE5T	850	825	123	120	3.0	1750	1000 - 10,000	75

Model Numbers ¹⁾	Reservoir Capacity (gal)	Factory Installed Accessories			Weight w/oil (lbs)
		Heat Exchanger	Roll Cage	4-Wrench Manifold	
ZE4204TB-QR (E)	1.2		●		120
ZE4204TB-QHR (E)	1.2	●	●		129
ZE4208TB-QHR (E)	1.8	●	●		135
ZE4208TB-QHMR (E)	1.8	●	●	●	141
ZE5204TJ-QHR (G, W)	1.2	●	●		142
ZE5208TJ-QHR (G, W)	1.8	●	●		148
ZE5208TJ-QHMR (G, W)	1.8	●	●	●	154
ZE5220TJ-QHR (G, W)	5.2	●	●		194

¹⁾ "B" suffix model numbers shown are 115 VAC, 1-phase, 50/60 Hz.
 "E" indicates pump available in 208-240V, 1 phase, 50/60 Hz with European plug and CE EMC compliant. Model number order example: **ZE4204TE-QR**.
 "J" indicates pump available in 460-480V, 3-phase, 50/60Hz. Model number order example: **ZE5208TJ-QHR**.
 "G" indicates pump available in 208-240V, 3-phase, 50/60 Hz. Model number order example: **ZE5208TG-QHR**.
 "W" indicates pump available in 380-415V, 3-phase, 50/60 Hz. Model number order example: **ZE5208TW-QHR**.

ZE4T ZE5T Series



Reservoir Capacity:

1.2 - 5.2 gallons

Flow at 10,000 psi:

60 - 120 in³/minute

Motor Size:

1.5 - 3.0 hp

Maximum Operating Pressure:

10,000 psi



Torque Wrench Pump Selection Matrix

For optimum speed and performance see the torque wrench pump selection matrix.

Page: 291



Accessories

Descriptions can be found in the ZU4T section.

Page: 301



Torque Wrench Hoses

Use Enerpac twin safety hoses to connect your torque wrench to the pump.

10,000 psi	
6.5 feet long, 2 hoses	THQ702T
19.5 feet long, 2 hoses	THQ706T
39 feet long, 2 hoses	THQ712T

▼ LA2504TX-QR, Hydraulic Torque Wrench Pump



Lightweight and Compact

Improved Operator Efficiency and Ergonomics

- Easy to lift, transport and maneuver
- Hand carry where no crane, hoist or elevator is available
- One person transport up ladders and stairs
- Ideal for use on narrow or constrained scaffolding, catwalks, pipe racks and lifts

High Productivity

- Proven 3-piston design provides leading fastening and breakout speed to stay on time and under budget
- ATEX certified to meet worksite compliance requirements

Reduce Equipment Downtime

- Roll cage with reinforcement to support and protect FRL
- Rugged 1/2" air supply connection with integrated roll cage support
- Key components are easy to access and service

Standard Features

- 15 foot pendant cord for mobility around work site
- 4 inch calibrated gauge with certificate, scale in psi and bar
- Roll cage and FRL



Torque Wrench Pump Selection Matrix

For optimum speed and performance see the torque wrench pump selection matrix.

Page: 291



Torque Wrenches

Optimized for use with Enerpac Hydraulic Torque Wrenches.

Enerpac offers a complete range of square drive and hexagon cassette torque wrenches.

Page: 239



Twin Torque Wrench Hoses

Use Enerpac THQ700 Series twin hoses with 10,000 psi pumps.

10,000 psi	
6.5 feet long, 2 hoses	THQ702T
19.5 feet long, 2 hoses	THQ706T
39 feet long, 2 hoses	THQ712T



ATEX Certified

The LAT-Series air-driven pumps are tested and certified according to the ATEX Directive 2014/34/EU.

The explosion protection is for Equipment Group II, Equipment Category 2 (Hazardous Area Zone 1), in Gas and/or Dust atmospheres.

Each LAT-Series air-driven pump contains the following markings:

Ex IIC T4 Gc,
Ex IIIC T135°C Dc

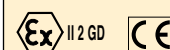

Air Hydraulic Torque Pumps



LAT-Series Hydraulic Torque Wrench Pump

The Enerpac LAT Torque Wrench Pump combines compact design and high productivity for bolting applications in areas hard to access with larger air powered pumps.

Whether on an offshore platform, refinery or mine—anywhere in the world, the pump is built for the toughest worksite environments.

Featuring a proven Enerpac piston design, reinforced FRL support and air supply connection, the LAT will provide years of reliable service with fastening and breakout speeds to keep you on schedule and under budget.

LAT Series



Reservoir Capacity:
0.8 gallon

Useable Reservoir Capacity:
0.5 gallon

Flow at Rated Pressure:
25 in³/minute

Maximum Operating Pressure:
10,000 psi

- ▼ Rugged 1/2" air supply connection with integrated roll cage support



- ▼ Roll cage design supports and protects FRL

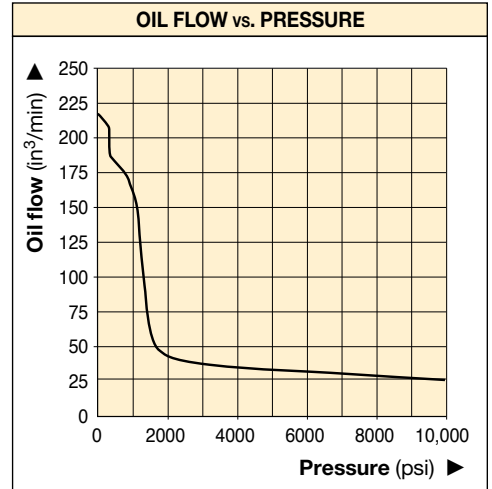

- ▼ Proven 3 piston design provides leading speed

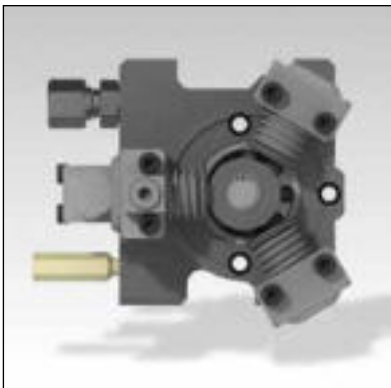

- ▼ Skid Rail accessory bolts to bottom of reservoir to prevent wear from rough surfaces Part No. **DD8365920K**



- ▼ LAT-Series, the portable and compact torque pump.



Reservoir Capacity (gal)	Model Number	Output Flow Rate (in ³ /min)			Valve Type	Air Pressure Range (psi)	Air Consumption (scfm)	Sound Level (dBA)	Dimensions (in)			Weight with Oil (lbs)
		No Load	5000 psi	10,000 psi					L	W	H	
0.8	LA2504TX-QR	214	34	25	4-way, 2-pos.	65-100	65	87-90	17.1	9.8	14.8	39.6

▼ ZA4204TX-QR



II 2 GD ck T4
DEKRA 0602



Z Tough.
Dependable.
Innovative.
CLASS



Torque Wrench Pump Selection Matrix

For optimum speed and performance see the torque wrench pump selection matrix.

Page: 291

- Two-speed operation and high by-pass pressure reduces cycle time for improved productivity
- Glycerin filled pressure gauge with transparent overlays in Ft.lbs and Nm for Enerpac torque wrenches provide a quick torque reference
- Regulator-Filter-Lubricator with removable bowls and auto drain is standard
- Ergonomic pendant allows remote operation up to 20 feet
- Valve technology reduces oil operating temperatures and withstands contaminants to increase pump reliability



Torque Wrench Hoses

Use Enerpac twin safety hoses to connect your torque wrench to the pump.

10,000 psi	
6.5 feet long, 2 hoses	THQ702T
19.5 feet long, 2 hoses	THQ706T
39 feet long, 2 hoses	THQ712T

▼ Most hydraulic torque wrenches can be powered by the Enerpac ZA4-Series torque wrench pump.



ZA4208TX-QR0P PowaPak™ Air Torque Pump

ZA4T Pump with stainless steel roll cage and certified lifting eye.

Air Driven Torque Pumps



ZA4T-Series Pump Applications

The ZA4T-Series pump is best suited to power medium to large size torque wrenches.

Patent-pending *Z-Class* technology provides high by-pass pressures for increased productivity. Its high power-to-weight ratio and compact design make it ideal for applications which require easy transport of the pump.

For further application assistance contact your local Enerpac office.

ATEX Certified

The ZA4T-series pumps are tested and certified to conform to the EU-ATEX Directive, 2014/34/EU.

The explosion protection is for Equipment Group II, Equipment Category 2 (Hazardous Area Zone 1), in Gas and /or Dust atmospheres.

The ZA4T-series pumps are marked with: Ex II 2 GD ck T4.



II 2 GD ck T4
DEKRA 0602

ZA4T Series



Reservoir Capacity:

1.2 and 1.8 gallons

Flow at 10,000 psi:

60 in³/minute

Air Consumption:

20 - 100 scfm

Maximum Operating Pressure:

10,000 psi



Accessory Options

Available by placing the following additional suffix at the end of the model number:

K = Skidbar

M = 4-wrench manifold

R = Roll cage

Page: **309**

OIL FLOW vs PRESSURE

100 psi dynamic air pressure
at 70 scfm

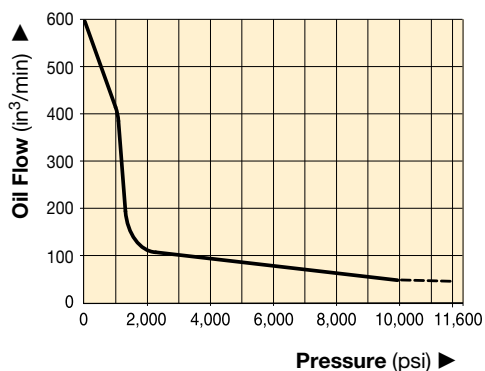

Gauge Overlay Kit

Gauge overlay kits are also available separately.

GT4015Q includes overlays for all S-, W-, RSL-, DSX and HMT-Series Torque Wrenches.

▼ **ZA4208TX-QR** for improved wrench performance and torque control at low pressure.



COMMON PUMP MODELS

For Use With Torque Wrenches	Maximum Operating Pressure (psi)	Model Number 1)	Reservoir Capacity (gal)	Weight with Oil (lbs)
For all S-, W-, RSL-, DSX and HMT-Series wrenches	10,000	ZA4204TX-Q	1.2	94
	10,000	ZA4208TX-Q	1.8	100
	10,000	ZA4204TX-QR*	1.2	101
	10,000	ZA4208TX-QR*	1.8	112

* With roll cage

1) All models meet CE safety requirements and all TÜV requirements.

▼ This is how a ZA4T-Series pump model number is built up:



1	2	3	4	5	6	7	8	8	8
Product	Motor	Flow	Valve	Reservoir	Valve	Voltage	Must	Options	Options
Type	Type	Group	Type	Size	Operation		be Q		

1 Product Type

Z = Pump Series

2 Motor Type

A = Air motor

3 Flow Group

4 = 60 in³/min @ 10,000 psi

4 Valve Type

2 = Torque Wrench Valve

5 Reservoir Capacity

04 = 1.2 gallon

08 = 1.8 gallons

6 Valve Operation

T = Air operated valve with pendant

7 Voltage

X = Not applicable

8 Factory installed features and options

Q = 10,000-psi coupler for use with S-, W- RSL-, DSX- and HMT-Series or other wrenches

K = Skidbar

M = 4-wrench manifold

R = Roll cage



How to Order Your ZA4T-Series Torque Pump

Ordering Example: Model No. ZA4208TX-QMR

10,000-psi pump for use with Enerpac S, W, RSL, DSX, and HMT-Series and other 10,000-psi torque wrenches, 2-gallon reservoir, 4-wrench manifold, and roll cage.

Refer to the torque wrench pump selection matrix for optimum wrench, pump and hose combinations.

Dimensions shown in inches.

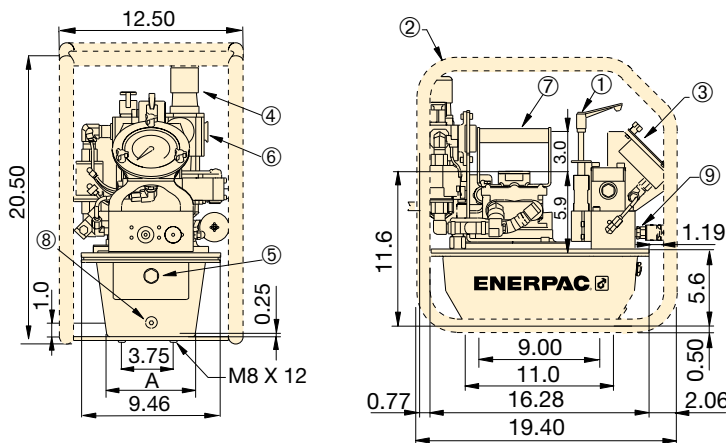

- ① User adjustable relief valve
- ② Roll bar cage (optional)
- ③ Gauge with overlays
- ④ Filter/lubricator/regulator
- ⑤ Oil level sight gauge
- ⑥ Air input 1/2" NPTF
- ⑦ Standard handle
- ⑧ Oil drain
- ⑨ 1/4"-18 NPTF Oil Outlet

▼ Most hydraulic torque wrenches can be powered by the Enerpac ZA4T-Series torque wrench pump.



ZA4T-Series Torque Pumps

Reservoir Size (useable gallons)	A (in)
1	6.0
1.75	8.1

ZA4T Performance							
Output Flow Rate (in ³ /min)				Dynamic Air Pressure Range (psi)	Air Consumption (scfm)	Sound Level at 100 psi Dynamic (dBA)	Relief Valve Adjustment Range (psi)
100 psi	700 psi	5,000 psi	10,000 psi				
600	500	80	60	60-100	20-100	80-95	1,400-10,000*

* Pump type (-Q) shown.

Torque Pump Options



Skidbar

- Provides greater pump stability on soft or uneven surfaces
- Provides two-handed lift

Accessory Kit No. *	Can be used on ZA4T-Series torque wrench pumps
SBZ-4	1.2 and 1.8-gallon reservoir

* Add suffix **K** for factory installation.
Skidbar weight 4.9 lbs.

Ordering Example:

Model No. ZA4208TX-QK



4-Wrench Manifold

- For simultaneous operation of multiple torque wrenches
- Can be factory installed or ordered separately

Accessory Kit No. *	Can be used on ZA4T-Series torque wrench pumps
ZTM-Q	for 10,000 psi torque wrenches

* Add suffix **M** for factory installation.
Manifold weight 7.9 lbs.

Ordering Example:

Model No. ZA4208TX-QM

ZA4T Series



Reservoir Capacity:

1.2 and 1.8 gallons

Flow at 10,000 psi:

60 in³/minute

Air Consumption:

20 - 100 scfm

Maximum Operating Pressure:

10,000 psi



ZA4208TX-QR0P PowaPak™ Air Torque Pump

ZA4T-Series Pump with stainless steel roll cage and certified lifting eye.



10,000 psi Spin-on Couplers

- Mounted on:
 - Torque wrench pumps with suffix "Q"
 - S, W, RSL, DSX and HMT-Series wrenches
 - THQ-Series hoses
 - 4-Wrench manifold ZTM-Q



Roll Cage

- Protects pump
- Provides greater pump stability

Accessory Kit No. *	Can be used on ZA4T-Series torque wrench pumps
ZRC-04	1.2 and 1.8-gallon reservoir

* Add suffix **R** for factory installation.
Roll bar cage weight 7.5 lbs.

Ordering Example:

Model No. ZA4208TX-QR



Twin Torque Wrench Hoses

Use Enerpac **THQ700** series twin hoses with 10,000 psi pumps.

10,000 psi	
6.5 feet long, 2 hoses	THQ702T
19.5 feet long, 2 hoses	THQ706T
39 feet long, 2 hoses	THQ712T

▼ HM10 Hydramax® Topside Tensioner



- Fifteen load cells from ¾" to 4" / M20 to M100
- Twin ports for quick connection of multiple tools
- High bolt-load capacity at maximum 21,750 psi (1500 bar)
- Long-stroke capability of 9/16 inch (15 mm) with over stroke elimination
- HM01 to HM05: mechanical over-stroke prevention, no spring return; HM06 to HM15: relief valve for over-stroke prevention, spring return
- Quick release bridge
- Stroke indicator
- Captive socket – eliminates falling object risk
- Interchangeable adapter kits available
- Anti-slip grip for more secure handling
- HM-Series HydraMax® Tensioners comply to following: Machine Directive 2006/42/EC, ASME B30.1, EN-ISO 4413:2010, EN-ISO 12100:2010



◀ Enerpac HM-Series HydraMax® tensioners have been designed to generate high-bolt loads associated with compact flanges, while providing versatility for maximum bolt coverage.

High Bolt Load Capacities, Superior Performance



HydraMax® Topside Tensioners

The HM-Series tensioners have been designed to fit all standard flanges, including ANSI, API and compact flanges based on Norsok L005 and generates 30% more load capacity than traditional tensioners.



Tensioning Pumps, Hoses and Couplers

High-pressure pumps, hoses and fittings matched for use with the Enerpac Bolt Tensioners. See enerpac.com

Page: 325



Ultra-High Pressure

This tool operates at ultra high-pressure, use only the specified fittings and hoses designed for these pressures.



How to Order HydraMax® Tensioners

To provide maximum flexibility, Load Cells are ordered separately from Adaptor and Bridge Kits. Example, to order a complete tensioner for a M24 x 3 threaded bolt order:

1 x Load Cell: **HM03-LC**

1 x Adaptor and Bridge Kit:

HM03BPM-NRS02430



Bolting Integrity Software

The software offers Tool selection, Bolt Load calculations and Tool pressure settings, as well as, a combined Application Data Sheet, and Joint Combination report. Custom Joint information can also be entered.

Page: 416

HydraMax® Topside Tensioners



Thread and Pitch Sizes

Contact Enerpac for different thread or pitch sizes. Alternative size adaptor kits can be supplied upon request.

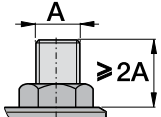

Minimum Stud Protrusion

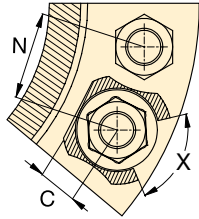

X = Minimum socket rotation 60°

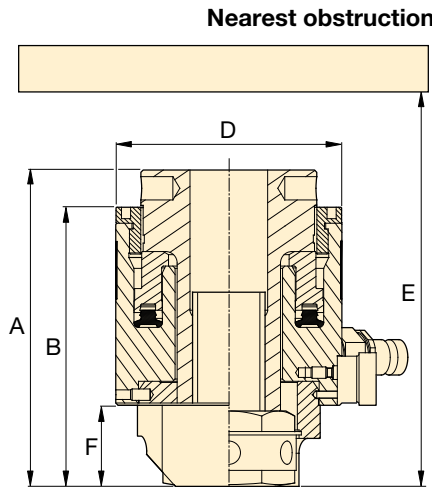

HM Series



Bolt Range:

3/4 - 1 1/2" | M20 - M39

Maximum Load Capacity:

15.1 - 70.2 tons

Stroke:

0.39 - 0.59 inch *

Maximum Operating Pressure:

21,750 psi

* Stroke HM01 models 0.39 inch

Strokes all other HM-models 0.59 inch

Load Cell Model Number*	Thread Size	Adaptor and Bridge Kit Model Number	Cylinder Effective Area (in ²)	Maximum Load Capacity (tons)	Dimensions (in)							Load Cell Weight (lbs)	Adaptor and Bridge Kit Weight (lbs)
					A	B	C	D	E min.	F	N min.		
HM01-LC	M20 x 2,5	HM01BPM-NRS02025	1.39	15.1	4.4	3.8	0.6	2.7	7.8	1.1	2.0	3.5	1.3
	3/4" - 10UN	HM01BP-NRS0750U10	1.39	15.1	4.4	3.8	0.6	2.7	7.8	1.1	2.0	3.5	1.3
HM02-LC	M20 x 2,5	HM02BPM-NRS02025	1.92	20.9	4.7	4.1	0.6	2.9	8.2	1.1	2.1	4.0	2.0
	M22 x 2,5	HM02BPM-NRS02225	1.92	20.9	4.7	4.1	0.6	2.9	8.2	1.1	2.1	4.0	2.0
	3/4" - 10UN	HM02BP-NRS0750U10	1.92	20.9	4.7	4.1	0.6	2.9	8.2	1.1	2.0	4.0	2.0
	7/8" - 9UN	HM02BP-NRS0875U09	1.92	20.9	4.7	4.1	0.7	2.9	8.2	1.1	2.2	4.0	1.8
HM03-LC	M20 x 2,5	HM03BPM-NRS02025	2.52	27.4	4.7	4.1	0.6	3.2	8.3	1.1	2.2	4.9	2.4
	M22 x 2,5	HM03BPM-NRS02225	2.52	27.4	4.7	4.1	0.6	3.2	8.3	1.1	2.3	4.9	2.4
	M24 x 3	HM03BPM-NRS02430	2.52	27.4	4.7	4.1	0.8	3.2	8.3	1.1	2.3	4.9	2.4
	3/4" - 10UN	HM03BP-NRS0750U10	2.52	27.4	4.7	4.1	0.6	3.2	8.3	1.1	2.2	4.9	2.4
	7/8" - 9UN	HM03BP-NRS0875U09	2.52	27.4	4.7	4.1	0.7	3.2	8.3	1.1	2.3	4.9	2.4
	1" - 8UN	HM03BP-NRS1000U08	2.52	27.4	4.9	4.3	0.8	3.2	8.5	1.3	2.4	4.9	2.4
HM04-LC	M22 x 2,5	HM04BPM-NRS02225	3.35	36.4	5.0	4.4	0.7	3.5	9.1	1.1	2.4	6.0	3.5
	M24 x 3	HM04BPM-NRS02430	3.35	36.4	5.1	4.4	0.8	3.5	9.1	1.1	2.5	6.0	3.5
	M27 x 3	HM04BPM-NRS02730	3.35	36.4	5.3	4.6	0.8	3.5	9.3	1.3	2.5	6.0	3.7
	M30 x 3,5	HM04BPM-NRS03035	3.35	36.4	5.4	4.7	0.9	3.5	9.4	1.4	2.6	6.0	3.7
	7/8" - 9UN	HM04BP-NRS0875U09	3.35	36.4	5.1	4.4	0.7	3.5	9.1	1.1	2.4	6.0	3.5
	1" - 8UN	HM04BP-NRS1000U08	3.35	36.4	5.3	4.6	0.8	3.5	9.3	1.3	2.5	6.0	3.7
	1 1/8" - 8UN	HM04BP-NRS1125U08	3.35	36.4	5.4	4.7	0.9	3.5	9.4	1.4	2.6	6.0	3.7
HM05-LC	M24 x 3	HM05BPM-NRS02430	4.27	46.4	5.1	4.5	0.7	3.9	9.2	1.1	2.7	7.3	4.2
	M27 x 3	HM05BPM-NRS02730	4.27	46.4	5.3	4.7	0.8	3.9	9.4	1.3	2.7	7.3	4.4
	M30 x 3,5	HM05BPM-NRS03035	4.27	46.4	5.5	4.8	0.9	3.9	9.5	1.4	2.8	7.3	4.4
	M33 x 3,5	HM05BPM-NRS03335	4.27	46.4	5.6	4.9	1.1	3.9	9.6	1.5	2.8	7.3	4.6
	1" - 8UN	HM05BP-NRS1000U08	4.27	46.4	5.3	4.7	0.8	3.9	9.4	1.3	2.7	7.3	4.6
	1 1/8" - 8UN	HM05BP-NRS1125U08	4.27	46.4	5.5	4.8	0.9	3.9	9.5	1.4	2.7	7.3	4.6
	1 1/4" - 8UN	HM05BP-NRS1250U08	4.27	46.4	5.6	4.9	1.1	3.9	9.6	1.5	2.8	7.3	4.6
HM06-LC	M30 x 3,5	HM06BPM-NRS03035	6.45	70.2	5.6	5.0	0.9	4.6	9.7	1.4	3.1	9.9	6.2
	M33 x 3,5	HM06BPM-NRS03335	6.45	70.2	5.7	5.1	1.1	4.6	9.8	1.5	3.2	9.9	6.4
	M36 x 4	HM06BPM-NRS03640	6.45	70.2	5.9	5.2	1.3	4.6	9.9	1.6	3.3	9.9	6.6
	M39 x 4	HM06BPM-NRS03940	6.45	70.2	6.0	5.3	1.3	4.6	10.0	1.8	3.3	9.9	6.8
	1 1/8" - 8UN	HM06BP-NRS1125U08	6.45	70.2	5.6	5.0	0.9	4.6	9.7	1.4	3.1	9.9	6.2
	1 1/4" - 8UN	HM06BP-NRS1250U08	6.45	70.2	5.7	5.1	1.1	4.6	9.8	1.5	3.2	9.9	6.4
	1 3/8" - 8UN	HM06BP-NRS1375U08	6.45	70.2	5.9	5.2	1.3	4.6	9.9	1.6	3.2	9.9	6.6
	1 1/2" - 8UN	HM06BP-NRS1500U08	6.45	70.2	6.0	5.3	1.3	4.6	10.0	1.8	3.3	9.9	6.8

* Tommy bar is included with Load Cell



Thread and Pitch Sizes

Contact Enerpac for different thread or pitch sizes. Alternative size adaptor kits can be supplied upon request.

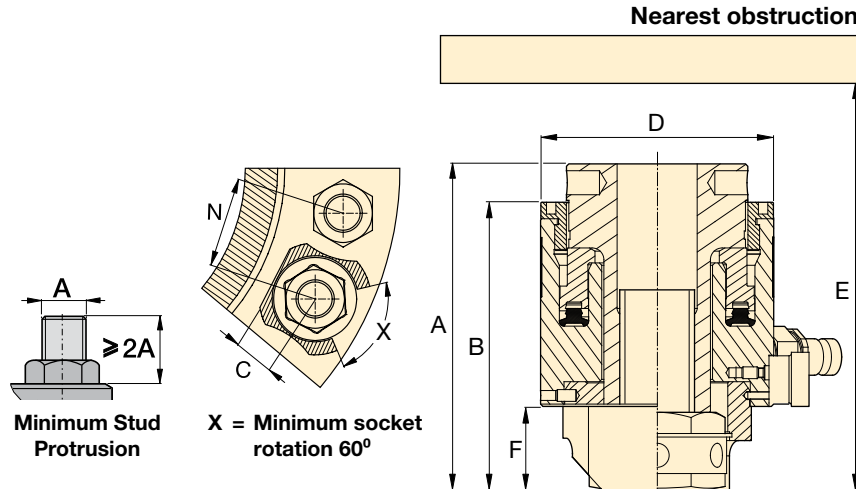

HM Series



Bolt Range:

1 1/4 - 2" | M33 - M52

Maximum Load Capacity:

83.9 - 131.9 tons

Stroke:

0.59 inch

Maximum Operating Pressure:

21,750 psi

Load Cell Model Number *	Thread Size	Adaptor and Bridge Kit Model Number	Cylinder Effective Area (in²)	Maximum Load Capacity (tons)	Dimensions (in)							Load Cell Weight (lbs)	Adaptor and Bridge Kit Weight (lbs)
					A	B	C	D	E min.	F	N min.		
HM07-LC	M33 x 3,5	HM07BPM-NRS03335	7.72	83.9	5.7	5.0	1.1	5.0	9.7	1.5	3.4	11.5	7.5
	M36 x 4	HM07BPM-NRS03640	7.72	83.9	5.8	5.2	1.3	5.0	9.8	1.6	3.4	11.5	7.7
	M39 x 4	HM07BPM-NRS03940	7.72	83.9	5.9	5.3	1.3	5.0	9.9	1.8	3.5	11.5	7.9
	M42 x 4,5	HM07BPM-NRS04245	7.72	83.9	6.1	5.4	1.3	5.0	10.0	1.9	3.6	11.5	8.2
	1 1/4" - 8UN	HM07BP-NRS1250U08	7.72	83.9	5.7	5.0	1.1	5.0	9.7	1.5	3.4	11.5	7.5
	1 3/8" - 8UN	HM07BP-NRS1375U08	7.72	83.9	5.8	5.2	1.3	5.0	9.8	1.6	3.4	11.5	7.7
	1 1/2" - 8UN	HM07BP-NRS1500U08	7.72	83.9	5.9	5.3	1.3	5.0	9.9	1.8	3.5	11.5	7.9
1 5/8" - 8UN	HM07BP-NRS1625U08	7.72	83.9	6.1	5.4	1.3	5.0	10.0	1.9	3.5	11.5	8.2	
HM08-LC	M36 x 4	HM08BPM-NRS03640	9.10	98.9	5.9	5.2	1.3	5.4	9.9	1.6	3.6	13.9	8.6
	M39 x 4	HM08BPM-NRS03940	9.10	98.9	6.0	5.3	1.3	5.4	10.0	1.8	3.7	13.9	8.8
	M42 x 4,5	HM08BPM-NRS04245	9.10	98.9	6.1	5.5	1.3	5.4	10.1	1.9	3.8	13.9	9.0
	M45 x 4,5	HM08BPM-NRS04545	9.10	98.9	6.2	5.6	1.5	5.4	10.3	2.0	3.8	13.9	9.7
	1 3/8" - 8UN	HM08BP-NRS1375U08	9.10	98.9	5.9	5.2	1.3	5.4	9.9	1.6	3.6	13.9	8.6
	1 1/2" - 8UN	HM08BP-NRS1500U08	9.10	98.9	6.0	5.3	1.3	5.4	10.0	1.8	3.7	13.9	8.8
	1 5/8" - 8UN	HM08BP-NRS1625U08	9.10	98.9	6.1	5.5	1.3	5.4	10.1	1.9	3.7	13.9	9.0
1 3/4" - 8UN	HM08BP-NRS1750U08	9.10	98.9	6.2	5.6	1.5	5.4	10.3	2.0	3.8	13.9	9.7	
HM09-LC	M39 x 4	HM09BPM-NRS03940	10.59	115.2	6.0	5.4	1.3	5.7	10.0	1.8	3.9	14.3	11.0
	M42 x 4,5	HM09BPM-NRS04245	10.59	115.2	6.1	5.5	1.3	5.7	10.1	1.9	3.9	14.3	13.4
	M45 x 4,5	HM09BPM-NRS04545	10.59	115.2	6.2	5.6	1.5	5.7	10.3	2.0	4.0	14.3	11.2
	M48 x 5	HM09BPM-NRS04850	10.59	115.2	6.4	5.7	1.6	5.7	10.4	2.1	4.0	14.3	12.1
	1 1/2" - 8UN	HM09BP-NRS1500U08	10.59	115.2	6.0	5.4	1.3	5.7	10.0	1.8	3.8	14.3	11.2
	1 3/8" - 8UN	HM09BP-NRS1625U08	10.59	115.2	6.1	5.5	1.3	5.7	10.2	1.9	3.9	14.3	11.2
	1 1/4" - 8UN	HM09BP-NRS1750U08	10.59	115.2	6.2	5.5	1.5	5.7	10.1	2.0	4.0	14.3	13.2
1 7/8" - 8UN	HM09BP-NRS1875U08	10.59	115.2	6.4	5.7	1.6	5.7	10.4	2.1	4.0	14.3	11.9	
HM10-LC	M42 x 4,5	HM10BPM-NRS04245	12.20	132.6	6.3	5.6	1.3	6.1	10.5	1.9	4.1	18.3	12.6
	M45 x 4,5	HM10BPM-NRS04545	12.20	131.9	6.4	5.7	1.5	6.1	10.6	2.0	4.2	18.3	12.6
	M48 x 5	HM10BPM-NRS04850	12.20	131.9	6.5	5.8	1.6	6.1	10.7	2.1	4.3	18.3	13.4
	M52 x 5	HM10BPM-NRS05250	12.20	131.9	6.7	6.0	1.7	6.1	10.8	2.3	4.3	18.3	13.9
	1 3/8" - 8UN	HM10BP-NRS1625U08	12.20	131.9	6.3	5.6	1.3	6.1	10.5	1.9	4.1	18.3	12.6
	1 1/4" - 8UN	HM10BP-NRS1750U08	12.20	131.9	6.4	5.7	1.5	6.1	10.6	2.0	4.2	18.3	12.3
	1 7/8" - 8UN	HM10BP-NRS1875U08	12.20	131.9	6.5	5.9	1.6	6.1	10.7	2.1	4.2	18.3	13.2
2" - 8UN	HM10BP-NRS2000U08	12.20	131.9	6.7	6.0	1.7	6.1	10.8	2.3	4.3	18.3	13.9	

* Tommy bar is included with Load Cell

HM-Series, HydraMax® Torsioners

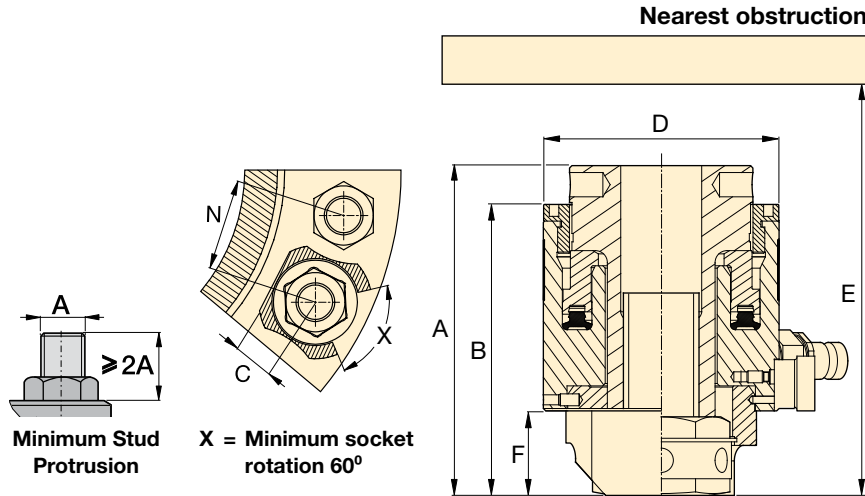

HM Series



Bolt Range:

1 3/4 - 4" | M45 - M100

Maximum Load Capacity:

171 - 522 tons

Stroke:

0.59 inch

Load Cell Model Number *	Thread Size **	Adaptor and Bridge Kit Model Number	Cylinder Effective Area (in ²)	Maximum Load Capacity (tons)	Dimensions (in)							Load Cell Weight (lbs)	Adaptor and Bridge Kit Weight (lbs)
					A	B	C	D	E min.	F	N min.		
HM11-LC	M45 x 4,5	HM11BPM-NRS04545	15.74	171.1	6.6	5.7	1.5	6.9	10.8	2.0	4.6	23.1	16.3
	M48 x 5	HM11BPM-NRS04850	15.74	171.1	6.7	5.8	1.6	6.9	10.9	2.1	4.6	23.1	17.4
	M52 x 5	HM11BPM-NRS05250	15.74	171.1	6.8	6.0	1.7	6.9	11.0	2.3	4.7	23.1	17.9
	M56 x 5,5	HM11BPM-NRS05655	15.74	171.1	7.2	6.3	2.0	6.9	11.4	2.6	4.8	23.1	20.1
	M60 x 5,5	HM11BPM-NRS06055	15.74	171.1	7.2	6.3	2.0	6.9	11.4	2.6	4.9	23.1	19.2
	1 3/4" - 8UN	HM11BP-NRS1750U08	15.74	171.1	6.6	5.7	1.5	6.9	10.8	2.0	4.6	23.1	16.5
	1 7/8" - 8UN	HM11BP-NRS1875U08	15.74	171.1	6.7	5.8	1.6	6.9	10.9	2.1	4.6	23.1	17.4
	2" - 8UN	HM11BP-NRS2000U08	15.74	171.1	6.8	6.0	1.7	6.9	11.0	2.3	4.7	23.1	17.9
2 1/4" - 8UN	HM11BP-NRS2250U08	15.74	171.1	7.2	6.3	2.0	6.9	11.4	2.6	4.8	23.1	19.4	
HM12-LC	M48 x 5	HM12BPM-NRS04850	19.72	214.4	6.7	5.8	1.6	7.6	11.0	2.1	5.0	29.3	21.4
	M52 x 5	HM12BPM-NRS05250	19.72	214.4	6.8	6.0	1.7	7.6	11.2	2.3	5.1	29.3	21.6
	M56 x 5,5	HM12BPM-NRS05655	19.72	214.4	7.2	6.3	2.0	7.6	11.5	2.6	5.2	29.3	23.6
	M60 x 5,5	HM12BPM-NRS06055	19.72	214.4	7.2	6.3	2.0	7.6	11.5	2.7	5.2	29.3	22.9
	M64 x 6	HM12BPM-NRS06460	19.72	214.4	7.3	6.5	2.2	7.6	11.7	2.7	5.3	29.3	24.5
	1 7/8" - 8UN	HM12BP-NRS1875U08	19.72	214.4	6.7	5.8	1.6	7.6	11.0	2.1	5.0	29.3	21.2
	2" - 8UN	HM12BP-NRS2000U08	19.72	214.4	6.8	6.0	1.7	7.6	11.2	2.3	5.1	29.3	21.6
	2 1/4" - 8UN	HM12BP-NRS2250U08	19.72	214.4	7.2	6.3	2.0	7.6	11.5	2.6	5.2	29.3	22.9
2 1/2" - 8UN	HM12BP-NRS2500U08	19.72	214.4	7.3	6.5	2.2	7.6	11.7	2.7	5.3	29.3	23.8	
HM13-LC	M64 x 6	HM13BPM-NRS06460	26.29	285.9	7.7	6.8	2.2	8.6	12.2	2.7	5.8	38.8	32.0
	M68 x 6	HM13BPM-NRS06860	26.29	285.9	7.7	6.8	2.2	8.6	12.2	2.7	5.9	38.8	36.4
	M72 x 6	HM13BPM-NRS07260	26.29	285.9	8.0	7.1	2.5	8.6	12.5	3.1	6.0	38.8	35.3
	M76 x 6	HM13BPM-NRS07660	26.29	285.9	8.1	7.3	2.7	8.6	12.7	3.2	6.0	38.8	35.9
	2 1/2" - 8UN	HM13BP-NRS2500U08	26.29	285.9	7.7	6.8	2.2	8.6	12.2	2.7	5.8	38.8	31.3
	2 3/4" - 8UN	HM13BP-NRS2750U08	26.29	285.9	8.0	7.1	2.5	8.6	12.5	3.1	5.9	38.8	34.8
3" - 8UN	HM13BP-NRS3000U08	26.29	285.9	8.1	7.3	2.7	8.6	12.7	3.2	6.3	38.8	34.8	
HM14-LC	M72 x 6	HM14BPM-NRS07260	36.35	395.3	8.0	7.1	2.5	10.2	12.6	3.1	6.8	56.9	45.9
	M76 x 6	HM14BPM-NRS07660	36.35	395.3	8.1	7.3	2.7	10.2	12.7	3.2	6.8	56.9	47.0
	M80 x 6	HM14BPM-NRS08060	36.35	395.3	8.1	7.3	2.7	10.2	12.7	3.2	6.9	56.9	46.7
	M85 x 6	HM14BPM-NRS08560	36.35	395.3	8.5	6.5	2.7	10.2	11.9	3.6	7.0	56.9	50.5
	M90 x 6	HM14BPM-NRS09060	36.35	395.3	8.7	7.8	3.1	10.2	13.3	3.8	7.1	56.9	51.4
	3" - 8UN	HM14BP-NRS3000U08	36.35	395.3	8.1	7.3	2.7	10.2	12.7	3.2	6.8	56.9	45.0
	3 1/4" - 8UN	HM14BP-NRS3250U08	36.35	395.3	8.5	6.5	2.7	10.2	11.9	3.6	7.0	56.9	50.0
3 1/2" - 8UN	HM14BP-NRS3500U08	36.35	395.3	8.7	7.8	3.1	10.2	13.3	3.8	7.2	56.9	52.7	
HM15-LC	M90 x 6	HM15BPM-NRS09060	48.06	522.7	8.7	7.8	3.1	11.7	13.3	3.8	7.8	71.6	66.1
	M95 x 6	HM15BPM-NRS09560	48.06	522.7	8.9	8.1	3.2	11.7	13.5	4.0	7.9	71.6	74.3
	M100 x 6	HM15BPM-NRS10060	48.06	522.7	9.1	8.3	3.5	11.7	13.7	4.2	8.0	71.6	77.4
	3 1/2" - 8UN	HM15BP-NRS3500U08	48.06	522.7	8.7	7.8	3.1	11.7	13.3	3.8	7.8	71.6	65.0
	3 3/4" - 8UN	HM15BP-NRS3750U08	48.06	522.7	8.9	8.1	3.2	11.7	13.5	4.0	7.9	71.6	72.3
4" - 8UN	HM15BP-NRS4000U08	48.06	522.7	9.1	8.3	3.5	11.7	13.7	4.2	8.3	71.6	75.0	

* Tommy bar is included with Load Cell

**Contact Enerpac for different thread or pitch sizes. Alternative size adaptor kits can be supplied upon request.

▼ GT-Series Topside Bolt Tensioners



Accurate & Reliable Extreme Performance Bolt Tensioner



Tensioning Pumps, Hoses and Couplers

High-pressure pumps, hoses and fittings matched for use with the Enerpac Bolt Tensioners.

See enerpac.com

Page: 325

- Seven load cells from 5/8" to 4 inches or from M16 to M105
- Twin ports for quick connection of multiple tools
- Only one size of bridge per size of load cell
- Detachable and rotational bridge simplifies tool positioning
- Full bridge window – increased access to socket
- Captive socket – eliminates falling object risk
- Piston stroke indicator
- Black surface treatment protects against corrosion
- Anti-slip grip for more secure handling
- Universal and multi-use tool
- GT-Series tensioners comply to Machine Directive 2006/42/CE, ASME B30.1, EN-ISO 4413:2010 and EN-ISO 12100:2010



How to Order

To provide maximum flexibility Load Cell and Bridges are ordered separately from Adaptor Kits.

Example, to order a complete tensioner for a M36 x 4 threaded bolt order:
1 x Load Cell and Bridge: **GT2-LCB**
1 x Adaptor Kit: **GT2PM-NRS03640**

Load Cell and Bridge Model Number *	Thread Size	Adaptor Kit Model Number	Cylinder Effective Area (in ²)	Maximum Load Capacity (ton)	Dimensions (in)							Load Cell and Bridge Weight (lbs)	Adaptor Kit Weight (lbs)
					A	B	C	D	E min.	F	N min.		
GT1-LCB	M16 x 2	GT1PM-NRS01620	2.32	25.2	5.3	4.4	1.1	3.4	9.6	1.7	2.2	6.6	3.5
	M18 x 2,5	GT1PM-NRS01825	2.32	25.2	5.3	4.4	1.1	3.4	9.6	1.7	2.3	6.6	3.3
	M20 x 2,5	GT1PM-NRS02025	2.32	25.2	5.3	4.4	1.1	3.4	9.6	1.7	2.3	6.6	3.1
	M24 x 3	GT1PM-NRS02430	2.32	25.2	5.3	4.4	1.1	3.4	9.6	1.7	2.4	6.6	2.9
	M27 x 3	GT1PM-NRS02730	2.32	25.2	5.3	4.4	1.1	3.4	9.6	1.7	2.5	6.6	2.6
	M30 x 3,5	GT1PM-NRS03035	2.32	25.2	5.3	4.4	1.1	3.4	9.6	1.7	2.6	6.6	2.2
	5/8" - 11UN	GT1P-NRS0625U11	2.32	25.2	5.3	4.4	1.1	3.4	9.6	1.7	2.2	6.6	3.5
	3/4" - 10UN	GT1P-NRS0750U10	2.32	25.2	5.3	4.4	1.1	3.4	9.6	1.7	2.3	6.6	3.1
	7/8" - 9UN	GT1P-NRS0875U09	2.32	25.2	5.3	4.4	1.1	3.4	9.6	1.7	2.4	6.6	2.9
	1" - 8UN	GT1P-NRS1000U08	2.32	25.2	5.3	4.4	1.1	3.4	9.6	1.7	2.5	6.6	2.6
1 1/8" - 8UN	GT1P-NRS1125U08	2.32	25.2	5.3	4.4	1.1	3.4	9.6	1.7	2.6	6.6	2.2	
GT2-LCB	M30 x 3,5	GT2PM-NRS03035	4.15	45.1	5.4	4.4	1.4	4.2	8.9	1.6	2.9	9.0	5.7
	M33 x 3,5	GT2PM-NRS03335	4.15	45.1	5.4	4.4	1.4	4.2	8.9	1.6	3.0	9.0	5.3
	M36 x 4	GT2PM-NRS03640	4.15	45.1	5.4	4.4	1.4	4.2	8.9	1.6	3.1	9.0	4.9
	M39 x 4	GT2PM-NRS03940	4.15	45.1	5.4	4.4	1.4	4.2	8.9	1.6	3.2	9.0	4.2
	1 1/8" - 8UN	GT2P-NRS1125U08	4.15	45.1	5.4	4.4	1.4	4.2	8.9	1.6	2.9	9.0	5.7
	1 1/4" - 8UN	GT2P-NRS1250U08	4.15	45.1	5.4	4.4	1.4	4.2	8.9	1.6	3.0	9.0	5.3
	1 3/8" - 8UN	GT2P-NRS1375U08	4.15	45.1	5.4	4.4	1.4	4.2	8.9	1.6	3.1	9.0	4.9
	1 1/2" - 8UN	GT2P-NRS1500U08	4.15	45.1	5.4	4.4	1.4	4.2	8.9	1.6	3.2	9.0	4.4

* Tommy bar is included with Load Cell

Topside Bolt Tensioners



Thread and Pitch Sizes

Contact Enerpac for different thread or pitch sizes.
Alternative size adaptor kits can be supplied upon request.

GT Series



Bolt Range:

5/8" - 4" | M16 - M105

Maximum Load Capacity:

86.4 - 444.9 tons

Stroke:

0.39 inch

Maximum Operating Pressure:

21,750 psi

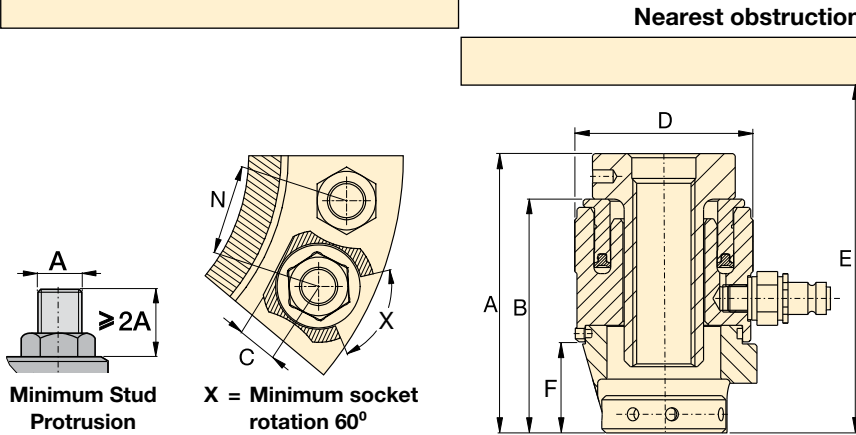

Load Cell and Bridge Model Number *	Thread Size	Adaptor Kit Model Number	Cylinder Effective Area (in ²)	Maximum Load Capacity (ton)	Dimensions (in)							Load Cell and Bridge Weight (lbs)	Adaptor Kit Weight (lbs)
					A	B	C	D	E min.	F	N min.		
GT3-LCB	M39 x 4	GT3PM-NRS03940	7.95	86.4	6.3	5.0	1.8	5.4	10.1	2.2	3.8	15.4	12.6
	M42 x 4,5	GT3PM-NRS04245	7.95	86.4	6.3	5.0	1.8	5.4	10.1	2.2	3.9	15.4	11.9
	M45 x 4,5	GT3PM-NRS04545	7.95	86.4	6.3	5.0	1.8	5.4	10.1	2.2	4.0	15.4	11.0
	M48 x 5	GT3PM-NRS04850	7.95	86.4	6.3	5.0	1.8	5.4	10.1	2.2	4.1	15.4	10.4
	M52 x 5	GT3PM-NRS05250	7.95	86.4	6.3	5.0	1.8	5.4	10.1	2.2	4.2	15.4	9.3
	1½" - 8UN	GT3P-NRS1500U08	7.95	86.4	6.3	5.0	1.8	5.4	10.1	2.2	3.7	15.4	12.6
	1⅝" - 8UN	GT3P-NRS1625U08	7.95	86.4	6.3	5.0	1.8	5.4	10.1	2.2	3.9	15.4	11.7
	1¾" - 8UN	GT3P-NRS1750U08	7.95	86.4	6.3	5.0	1.8	5.4	10.1	2.2	4.0	15.4	11.0
	1⅞" - 8UN	GT3P-NRS1875U08	7.95	86.4	6.3	5.0	1.8	5.4	10.1	2.2	4.1	15.4	10.1
2" - 8UN	GT3P-NRS2000U08	7.95	86.4	6.3	5.0	1.8	5.4	10.1	2.2	4.2	15.4	9.3	
GT4-LCB	M52 x 5	GT4PM-NRS05250	15.17	164.9	7.1	5.6	2.4	6.9	11.1	2.8	4.8	26.9	23.6
	M56 x 5,5	GT4PM-NRS05655	15.17	164.9	7.1	5.6	2.4	6.9	11.1	2.8	4.9	26.9	22.3
	M60 x 5,5	GT4PM-NRS06055	15.17	164.9	7.1	5.6	2.4	6.9	11.1	2.8	5.0	26.9	20.7
	M64 x 6	GT4PM-NRS06460	15.17	164.9	7.1	5.6	2.4	6.9	11.1	2.8	5.1	26.9	19.4
	M68 x 6	GT4PM-NRS06860	15.17	164.9	7.1	5.6	2.4	6.9	11.1	2.8	5.2	26.9	17.9
	2" - 8UN	GT4P-NRS2000U08	15.17	164.9	7.1	5.6	2.4	6.9	11.1	2.8	4.7	26.9	23.6
	2¼" - 8UN	GT4P-NRS2250U08	15.17	164.9	7.1	5.6	2.4	6.9	11.1	2.8	5.0	26.9	21.4
2½" - 8UN	GT4P-NRS2500U08	15.17	164.9	7.1	5.6	2.4	6.9	11.1	2.8	5.2	26.9	18.7	
GT5-LCB	M68 x 6	GT5PM-NRS06860	23.37	254.2	8.0	6.2	3.1	8.3	11.9	3.4	5.8	38.3	38.1
	M72 x 6	GT5PM-NRS07260	23.37	254.2	8.0	6.2	3.1	8.3	11.9	3.4	5.9	38.3	36.2
	M76 x 6	GT5PM-NRS07660	23.37	254.2	8.0	6.2	3.1	8.3	11.9	3.4	6.0	38.3	34.2
	M80 x 6	GT5PM-NRS08060	23.37	254.2	8.0	6.2	3.1	8.3	11.9	3.4	6.1	38.3	32.2
	2½" - 8UN	GT5P-NRS2500U08	23.37	254.2	8.0	6.2	3.1	8.3	11.9	3.4	5.8	38.3	39.2
	2¾" - 8UN	GT5P-NRS2750U08	23.37	254.2	8.0	6.2	3.1	8.3	11.9	3.4	6.0	38.3	35.9
	3" - 8UN	GT5P-NRS3000U08	23.37	254.2	8.0	6.2	3.1	8.3	11.9	3.4	6.2	38.3	32.6
3¼" - 8UN	GT5P-NRS3250U08	23.37	254.2	8.0	6.2	3.1	8.3	11.9	3.4	6.3	38.3	28.9	
GT6-LCB	M80 x 6	GT6PM-NRS08060	29.41	319.8	8.6	6.8	3.2	9.4	12.7	3.7	6.6	61.3	49.2
	M85 x 6	GT6PM-NRS08560	29.41	319.8	8.6	6.8	3.2	9.4	12.7	3.7	6.7	61.3	46.3
	M90 x 6	GT6PM-NRS09060	29.41	319.8	8.6	6.8	3.2	9.4	12.7	3.7	6.9	61.3	42.8
	M95 x 6	GT6PM-NRS09560	29.41	319.8	8.6	6.8	3.2	9.4	12.7	3.7	7.0	61.3	39.7
	3¼" - 8UN	GT6P-NRS3250U08	29.41	319.8	8.6	6.8	3.2	9.4	12.7	3.7	6.8	61.3	45.6
	3½" - 8UN	GT6P-NRS3500U08	29.41	319.8	8.6	6.8	3.2	9.4	12.7	3.7	7.1	61.3	41.4
	3¾" - 8UN	GT6P-NRS3750U08	29.41	319.8	8.6	6.8	3.2	9.4	12.7	3.7	7.4	61.3	37.0
GT7-LCB	M100 x 6	GT7PM-NRS10060	40.90	444.9	9.6	7.2	3.5	10.9	13.1	4.3	7.7	84.2	62.8
	M105 x 6	GT7PM-NRS10560	40.90	444.9	9.6	7.2	3.5	10.9	13.1	4.3	7.8	84.2	60.2
	4" - 8UN	GT7P-NRS4000U08	40.90	444.9	9.6	7.2	3.5	10.9	13.1	4.3	8.0	84.2	60.2

* Tommy bar is included with Load Cell

▼ Aquajack® Tensioner EAJ2LC with Quick Fastening Nut



- Compact design
- Long piston stroke
- Misalignment compensation
- Quick, simple hose connection
- Visible piston stroke indication
- ‘No spill’ overstroke elimination
- Quick fastening or solid reaction nut

▼ *Guaranteed to save time and increase efficiency, Aquajack® tensioners improve diver safety, productivity and reduce diver fatigue.*



The Most Cost-Effective Solution to Subsea Bolt or Stud Tightening



Quick Fastening Nut Design

Easily positioned in poor visibility conditions, Aquajack® subsea tensioners feature a

compact design and long piston stroke. The unique Split Nut® design of these tools allows rapid application to long bolts and damaged threads, and rapid tool removal.



No Oil Spillage or Over-Striking

Innovative tool design ensures maximum tool strokes can be used without over-stroking the piston or oil spillage. Guaranteed to save time and increase efficiency, Aquajack® subsea tensioners improve diver safety, productivity and reduce diver fatigue.

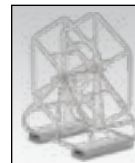
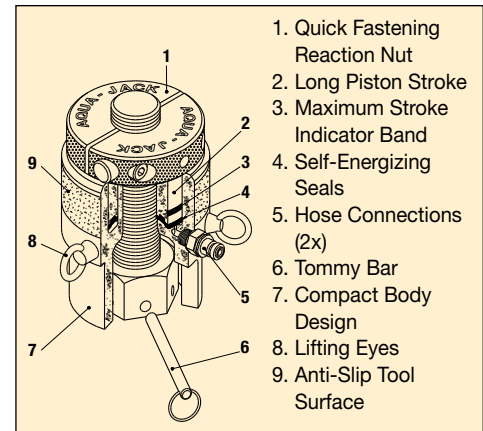

Hose Reel and Stand

Stainless steel stand with 21,750 psi hoses from 98 up to 885 ft. lengths. All hose reels are built up with multiple 98 ft. length hoses.

Aquajack® Subsea Tensioners

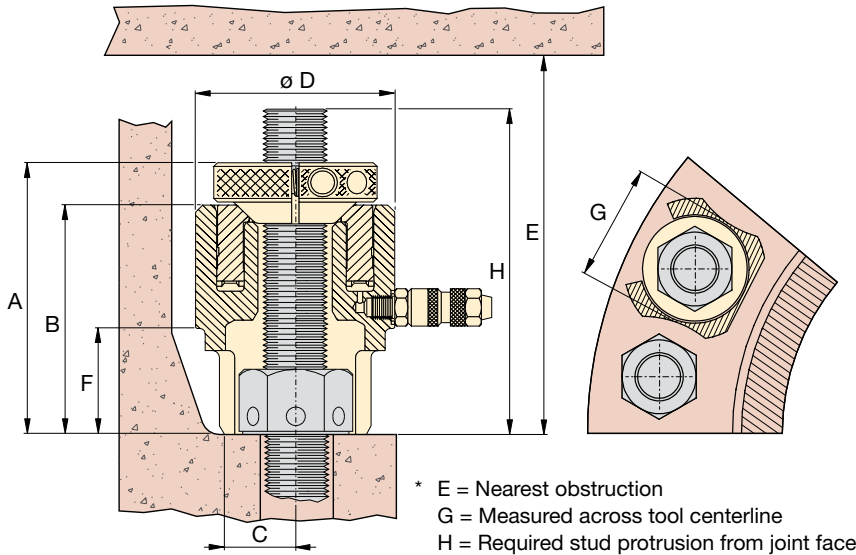

EAJ Series



Bolt Range:

3/4" - 3 1/2" | M20 - M90

Maximum Load Capacity:

17.0 - 260 tons

Maximum Operating Pressure:

21,750 psi

Load Cell Model Number *	Thread Size	Quick Fastening Nut Model Number	Cylinder Effective Area (in ²)	Maximum Load Capacity (ton)	Stroke (in)	Dimensions (in)								Tool Wt. (lbs)
						A	B	C	D	E*	F	G*	H*	
EAJ1LC	3/4" - 10 UN	EAJ1QFN0750U10	1.56	17.0	0.79	4.49	3.58	0.75	2.60	8.54	1.38	2.09	4.69	3.31
	7/8" - 9 UN	EAJ1QFN0875U09												
	M20 x 2,5	EAJ1QFNM02025												
	M22 x 2,5	EAJ1QFNM02225												
EAJ2LC	1" - 8 UN	EAJ2QFN1000U08	2.57	28.0	1.18	5.79	4.72	0.98	3.23	11.38	1.97	2.44	5.98	6.61
	M24 x 2,5	EAJ2QFNM02425												
	M27 x 3,0	EAJ2QFNM02730												
	1 1/8" - 8 UN	EAJ2QFN1125U08												
EAJ3LC	1 1/4" 8 UN	EAJ3QFN1250U08	3.91	42.6	1.18	6.20	5.16	1.10	3.86	12.09	2.28	3.07	6.42	9.92
	M33 x 3,5	EAJ3QFNM03335												
	1 3/8" - 8 UN	EAJ3QFN1375U08												
	M36 x 4,0	EAJ3QFNM03640												
EAJ4LC	1 1/2" - 8 UN	EAJ4QFN1500U08	5.71	62.2	1.18	6.73	5.35	1.30	4.49	12.56	2.48	3.58	6.93	13.23
	M39 x 4,0	EAJ4QFN03940												
	1 5/8" - 8 UN	EAJ4QFN1625U08												
	M42 x 4,5	EAJ4QFNM04245												
EAJ5LC	1 3/4" - 8 UN	EAJ5QFN1750U08	9.16	99.6	1.18	7.24	5.75	1.57	5.47	13.46	2.76	4.49	7.44	19.84
	M45 x 4,5	EAJ5QFNM04545												
	1 7/8" - 8 UN	EAJ5QFN1875U08												
	M48 x 5,0	EAJ5QFNM04850												
	2" - 8 UN	EAJ5QFN2000U08												
EAJ6LC	M52 x 5,0	EAJ5QFNM05250	12.88	140.2	1.18	7.91	6.34	1.93	6.46	14.45	3.23	5.43	8.11	28.66
	M56 x 5,5	EAJ6QFNM05655												
	2 1/4" - 8 UN	EAJ6QFN2250U08												
	M60 x 5,5	EAJ6QFNM06055												
EAJ7LC	M64 x 6,0	EAJ6QFNM06460	19.17	208.6	1.18	9.06	7.01	2.95	7.56	15.75	3.74	6.06	9.25	41.89
	M68 x 6,0	EAJ7QFNM06860												
	2 3/4" - 8 UN	EAJ7QFN2750U08												
	M72 x 6,0	EAJ7QFNM07260												
EAJ8LC	M76 x 6,0	EAJ7QFNM07660	23.98	260.9	1.18	9.72	7.60	2.68	8.39	16.22	4.29	7.17	9.92	54.01
	3" - 8 UN	EAJ7QFN3000U08												
	M80 x 6,0	EAJ8QFNM08060												
	3 1/4" - 8 UN	EAJ8QFN3250U08												
	M85 x 6,0	EAJ8QFNM08560												
3 1/2" - 8 UN	EAJ8QFN3500U08													
	M90 x 6,0	EAJ8QFNM09060												

* Tommy Bar is included with Load Cell.

▼ PGT-Series Single-Stage and Double-Deck Tensioners



High Precision, Low Maintenance



Tensioner Pumps

Electric, pneumatic and manual high-pressure tensioning pumps are available for use with Enerpac hydraulic tensioners.

Page: 239



Hoses and Fittings

High-pressure hoses and fittings for use with Enerpac tensioning systems are available.

Page: 325

- PGT-Series Bolt Tensioners are designed for critical fastening applications in wind, steam and gas turbines
- A broad range of single stage and double deck tensioners provide high performance in tight spaces associated with Power Generation applications
- PGT-Series Bolt Tensioners are loaded with performance enhancing features such as Auto-Retract Pistons, Cycle Counters and a premium coating to offer the ultimate in efficiency, durability and ease of use

Description	PGTS Single Stage	PGTD Double Deck
Auto-Retract Piston	✓	✓
Zinc Coating	✓	✓
Geared Nut-Rundown	✓	✓
Over-stroke Indicator	✓	✓
Over-stroke Preventer	✓	✓
Single Male Fitting	✓	✓
Swivel Manifold	+	+
Cycle Counter	-	+

✓ = Standard on tensioner

⊕ = Possible option

- = Option not available

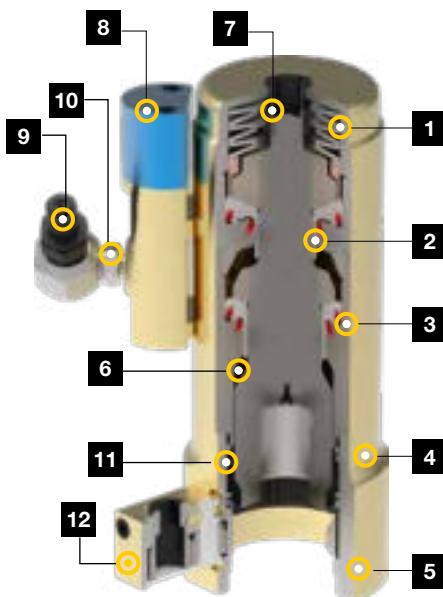

- 1. Auto-retract piston:** Simplifies use and improves speed of operation.
- 2. Long-life puller:** For maximum durability.
- 3. Long-life seals:** For maximum durability and extended service life intervals.
- 4. Corrosion protection:** Zinc coating provides best-in-class corrosion resistance.
- 5. Interchangeable bridge:** For optimal application fit.
- 6. Over-stroke preventer:** Mechanically prevents over-stroke, extending cylinder life.
- 7. Over-stroke indicator:** Extends cylinder life by helping to prevent over-stroking of cylinder.
- 8. Optional counter:** Helps indicate when maintenance is due to maximize uptime.
- 9. Quick-disconnect coupler:** For safe, simple hydraulic connection.
- 10. Optional 360° swivel:** available for additional hose positioning flexibility.
- 11. Spring-loaded nut engagement:** Keeps socket positioned on nut for faster and easier seating process.
- 12. Auto-engage nut rundown:** For rapid and accurate seating of nuts.

▲ The model above illustrates a typical tool configuration. Actual model configurations vary.

Power Generation Bolt Tensioners



Options

Fitting Type

SW = Swivel manifold with single male fitting
Example: **PGTS2436SW**

Cycle-Counter

C = Cycle Counter (not available on PGTS-models)
Example: **PGTD3655SWC**

- ① Puller bar square drive
- ② Swivel manifold with single male fitting
- ③ Single male fitting
- ④ Nut run down gear box

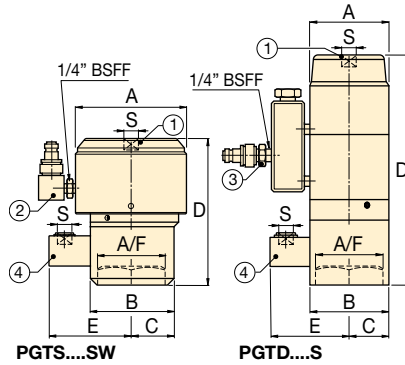

PGT Series



Bolt Range:

M20 - M72

Load Range:

23 - 334 tons

Maximum Operating Pressure ¹⁾:

19,575 - 21,750 psi

¹⁾ Max. Pressure varies, see specification table for details.

▼ SPECIFICATION TABLE

Tensioner Type	Thread Diameter (mm)	Model Number (with single male fitting)	Nut Size A/F (in)	Max. Pressure (psi)	Hyd. Pres. Area (in ²)	Max. Load Cap. (tons)	Stroke (in)	Dimensions (in)					Weight (lbs)	Bolt Protrusion (in)		
								A	B	C	D	E		S* (in)	min.	max.
Single Stage	M20 x 2,5	PGTS2030S	1.18	21,750	2.10	22.9	0.28	2.52	2.52	1.26	3.19	3.07	3/8	4.41	1.73	2.17
	M24 x 3,0	PGTS2436S	1.42	21,750	3.02	32.8	0.28	3.03	3.03	1.22	3.86	3.20	3/8	6.39	1.93	2.44
	M27 x 3,0	PGTS2742S	1.65	21,750	4.10	44.6	0.31	3.62	2.95	1.34	5.08	3.27	3/8	10.58	2.36	2.76
	M30 x 3,5	PGTS3046S	1.81	21,750	4.97	54.0	0.31	3.90	3.35	1.50	5.28	3.46	3/8	12.79	2.68	2.87
	M33 x 3,5	PGTS3350S	1.97	21,750	6.14	66.8	0.31	4.17	3.54	1.57	5.59	3.54	3/8	14.88	2.95	3.94
	M36 x 4,0	PGTS3655S	2.17	21,750	6.92	75.3	0.35	4.37	3.54	2.19	5.04	3.75	1/2	14.11	2.90	3.74
	M39 x 4,0	PGTS3960S	2.36	21,750	8.62	93.8	0.39	4.86	4.09	1.81	6.30	3.78	3/8	21.54	3.50	4.53
	M42 x 4,5	PGTS4265S	2.56	21,750	9.70	105.6	0.39	5.28	4.53	2.65	6.97	3.90	1/2	20.94	3.11	4.53
	M45 x 4,5	PGTS4570S	2.76	21,750	11.63	126.6	0.39	5.63	4.69	2.07	6.61	4.02	3/8	29.10	3.86	4.57
	M48 x 5,0	PGTS4875S	2.95	21,750	13.00	141.5	0.39	5.98	4.92	2.20	6.22	4.17	3/8	29.32	4.06	4.69
	M52 x 5,0	PGTS5280S	3.15	21,750	15.65	170.2	0.39	6.50	5.28	2.30	6.73	4.25	3/8	39.46	4.17	4.65
	M56 x 5,5	PGTS5685S	3.35	21,750	18.08	196.7	0.39	6.97	5.59	2.44	6.69	4.41	3/8	44.97	4.57	5.04
	M60 x 5,5	PGTS6090S	3.54	21,750	20.89	227.3	0.39	7.48	5.98	2.60	7.32	4.53	3/8	54.59	4.86	5.39
	M64 x 6,0	PGTS6495S	3.74	21,750	23.74	258.3	0.39	7.87	6.26	2.70	8.15	4.65	1/2	67.68	5.39	5.91
	M68 x 6,0	PGTS68100S	3.94	21,750	27.11	295.0	0.39	8.41	6.65	2.85	8.11	4.84	1/2	75.62	5.35	5.83
M72 x 6,0	PGTS72105S	4.13	21,750	30.69	333.9	0.39	8.86	7.01	2.99	8.78	4.96	1/2	88.85	5.94	6.57	
Double Deck	M24 x 3,0	PGTD2436S	1.42	19,575	3.55	34.8	0.24	4.69	3.03	1.22	7.28	3.19	3/8	10.14	2.09	2.34
	M27 x 3,0	PGTD2742S	1.65	19,575	4.56	44.6	0.24	4.92	2.95	1.34	7.72	3.28	3/8	11.57	2.36	2.68
	M30 x 3,5	PGTD3046S	1.81	19,575	5.31	52.0	0.28	5.28	3.35	1.46	7.68	3.46	3/8	12.70	2.36	2.76
	M33 x 3,5	PGTD3350S	1.97	19,575	6.62	64.8	0.28	5.59	3.03	1.52	8.19	3.54	3/8	14.70	2.56	3.03
	M36 x 4,0	PGTD3655S	2.17	19,575	7.74	75.8	0.31	5.98	3.27	1.61	8.58	3.66	1/2	17.06	2.76	3.43
	M39 x 4,0	PGTD3960S	2.36	19,575	9.70	95.0	0.39	6.26	4.09	1.89	10.47	3.78	3/8	27.56	3.31	3.66
	M42 x 4,5	PGTD4265S	2.56	19,575	10.64	104.2	0.39	6.69	4.09	2.05	9.78	3.90	1/2	25.02	3.23	3.58
	M45 x 4,5	PGTD4570S	2.76	19,575	12.93	126.6	0.39	6.97	4.69	2.09	11.57	4.09	3/8	38.91	3.82	4.21
	M48 x 5,0	PGTD4875S	2.95	19,575	14.62	143.1	0.39	4.53	4.92	2.26	11.97	4.17	3/8	44.31	4.06	4.45
	M52 x 5,0	PGTD5280S	3.15	19,575	17.50	171.3	0.39	4.88	5.28	2.40	12.91	4.25	3/8	57.54	4.33	4.94
	M56 x 5,5	PGTD5685S	3.35	19,575	20.06	196.4	0.39	5.20	5.59	2.56	13.62	4.41	3/8	66.14	4.61	5.22
	M60 x 5,5	PGTD6090S	3.54	19,575	23.30	228.2	0.39	5.55	5.98	2.78	14.65	4.53	3/8	81.90	4.92	5.63
	M64 x 6,0	PGTD6495S	3.74	19,575	26.54	259.9	0.39	5.94	6.26	2.99	15.20	4.69	1/2	94.80	5.24	6.00
	M68 x 6,0	PGTD68100S	3.94	19,575	30.25	296.2	0.39	6.30	6.69	3.15	15.67	4.84	1/2	109.13	5.43	6.30
	M72 x 6,0	PGTD72105S	4.13	19,575	34.06	333.6	0.39	6.73	6.97	3.48	16.89	4.96	1/2	132.50	5.75	6.73

* Dimension S = Square Drive of Puller Bar and Gear Box.

▼ FTR-Series Foundation Bolt Tensioner



High Precision, Low Maintenance



FTR-Series Foundation Bolt Tensioners

FTR-Series Foundation Bolt Tensioners are designed specifically for tensioning wind tower foundation bolts. These tensioners provide the speed and precision required by this critical application.

Potential thread fit problems are eliminated through the use of existing rebar hex nuts as a reaction point.

The FTR-Series includes long-stroke models, which provide greater speed and ease of use by enabling applications to be completed in a single pull.

- **FTR-Series Foundation Bolt Tensioners provide fast, accurate and easy tightening of external or internal ring wind tower foundations**
- **Standard models are available for 75, 150 ksi and metric style Williams, Dyson and Macalloy® bar types**
- **Long-stroke options accelerate process with single-pull tensioning**

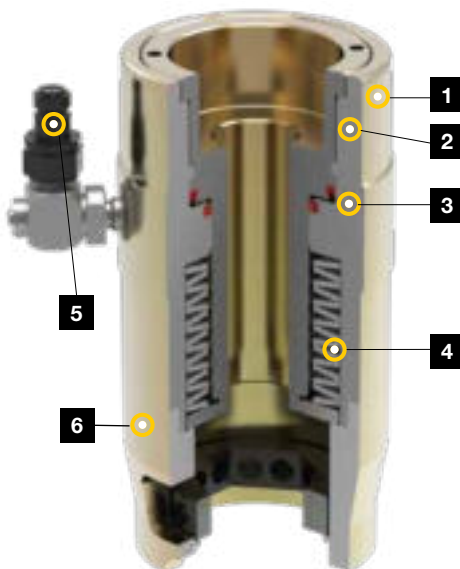

- 1. Corrosion protection:** Zinc coating provides best-in-class corrosion resistance.
- 2. Over-stroke indicator:** Extends life by helping to prevent over-stroking of cylinder.
- 3. Long-life seals:** For maximum durability and extended service life intervals.
- 4. Auto-retract piston:** Simplifies use and improves speed of operation.
- 5. Quick-disconnect coupler:** For safe, simple hydraulic connection. *OPTIONAL 360° swivel available for additional hose positioning flexibility.*
- 6. Interchangeable bridge:** For optimal application fit.

▼ *FTR-Series Foundation Bolt Tensioner. Manual wrench (not included) required to apply up to 22 Ft.lbs of torque during installation of models that feature run down gears.*



Foundation Bolt Tensioners

▼ This is how a FTR-Series Foundation Bolt Tensioner Model Number is Built Up:



1	2	3	4	5	6
Product Type	Bar Grade	Bar Size Designation	Stroke	Fitting Type	Run Down Gear

1 Product Type

FTR = Foundation Tensioner, Round

2 Bar Grade

75 = 75 ksi
150 = 150 ksi (or metric designation)

3 Bar Size Designation

Example: 14 = No. 14 bar

4 Maximum Stroke

Example: 20 = 20 mm (0.79 inch) max. stroke

5 Fitting Type

SW = Includes swivel manifold with single male fitting

6 Run Down Gear

G = Includes Run Down Gear (available in select models)

FTR Series



Load Range:

0 - 308 tons

Maximum Operating Pressure*:

21,750 psi / 1500 bar

* Max. Pressure varies, see specification table for details.



Tensioner Pumps

Electric, pneumatic and manual high-pressure tensioning pumps are available for use with Enerpac hydraulic tensioners.

Page: 239



Hoses and Fittings

High-pressure hoses and fittings for use with Enerpac tensioning systems are available.

Page: 325

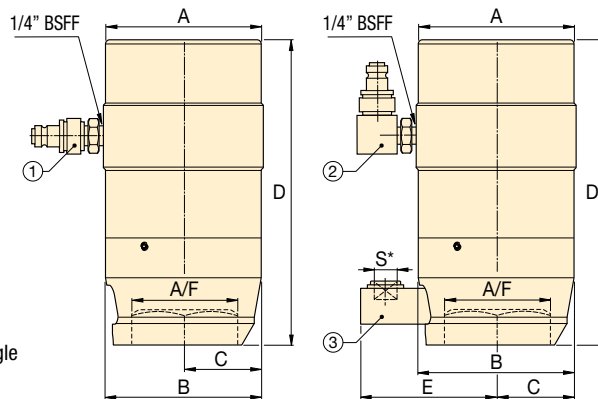

FTR...S

FTR...SWG

- ① Single male fitting
- ② Swivel manifold with single male fitting
- ③ Nut run down gear box

▼ SPECIFICATION TABLE

Bar Grade	Bolt Diameter		Bar Size Designation	Model Number	Nut A/F	Maximum Pressure	Hydraulic Pressure Area	Load Capacity	Stroke	Dimensions (in)					Wt. (lbs)	Min. Bolt Protrusion (in)
	(in)	(mm)								A	B	C	D	E		
75 ksi	1.38	35	#10	FTR751010S	2.00	17,400	4.86	42.3	0.39	3.90	3.48	1.74	6.42	-	12.9	7.87
	1.38	35	#10	FTR751025S	2.00	17,400	4.84	42.1	0.98	4.53	4.02	1.65	8.64	-	24.1	9.84
	1.50	38	#11	FTR751110S	2.25	21,750	4.86	52.8	0.39	3.90	3.86	1.50	7.01	-	12.1	8.66
	1.50	38	#11	FTR751125SG	2.25	21,750	4.84	52.7	0.98	4.53	4.02	2.01	8.92	3.78	25.3	10.24
	1.88	48	#14	FTR751420S	2.75	16,965	9.44	80.1	0.79	5.20	5.20	2.60	10.55	-	40.2	12.40
150 ksi	1.44	37	1.25	FTR15012510S	2.25	16,965	8.34	90.8	0.39	4.37	4.33	1.57	7.01	-	18.2	8.66
	1.56	40	1.375	FTR15013810S	2.50	21,750	8.34	90.8	0.39	4.37	4.33	1.50	7.01	-	17.8	8.86
	2.75	70	2.50	FTR15025025S	4.25	21,750	28.27	307.5	1.00	8.44	8.35	3.39	13.68	-	127.8	17.72
10.9	1.42	36	36	FTR1093610SG	2.36	21,750	5.92	64.4	0.39	4.02	3.90	1.57	6.93	3.74	19.0	7.68

Gear box square drive dimension S = 1/2 inch.

▼ FTE-Series Elliptical Foundation Tensioner



High Precision, Low Maintenance



FTE-Series, Foundation Bolt Tensioners

Similar to Standard Foundation Tensioners, Elliptical Tensioners were designed specifically for foundation fastening applications on wind towers, and utilize the existing hex nut as a reaction point in order to eliminate thread fit misalignment.

Unlike Standard FTR-Series Tensioners, FTE-Series Tensioners feature an elliptical geometry, which enables fit in narrow access foundation applications, without reducing load capabilities.

Operators may access the nut with a Tommy bar rather than employing the use of an offset rundown gear.

Elliptical tensioners are ideal for close clearance applications, or as a universal tool that will work in nearly any foundation application, whether standard or narrow access.

- **FTE-Series Foundation Bolt Tensioners provide fast and accurate performance in difficult, narrow access foundation tensioning applications**
- **Standard models are available for 75, 150 ksi and metric style Williams, Dyson and Macalloy® bar types**
- **Ideal universal solution that fits both standard and narrow access applications**

-
- 1. Max. stroke Indicator:** Extends life by helping to prevent over-stroking of cylinder.
 - 2. Long-life seals:** For maximum durability and extended service life intervals.
 - 3. Auto-retract piston:** Simplifies use and improves speed of operation.
 - 4. Elliptical form:** Provides access to close clearance applications.
 - 5. Corrosion protection:** Zinc coating provides best-in-class corrosion resistance.
 - 6. Quick-disconnect coupler (not shown):** For safe, simple hydraulic connection. *OPTIONAL 360° swivel available for additional hose positioning flexibility.*

▼ FTE-Series, Foundation Bolt Tensioner, designed to fit both standard and narrow access foundation applications.



Foundation Bolt Tensioners (Elliptical)

▼ This is how an FTE-Series Foundation Bolt Tensioner Model Number is Built Up:



1 Product Type

FTE = Foundation Tensioner, Elliptical

2 Bar Grade

75 = 75 ksi
150 = 150 ksi
 (or metric designation)

3 Bar Size Designation

Example: 10 = No. 10 bar

4 Fitting Type

S = Includes single male fitting
SW = Includes swivel manifold with single male fitting

FTE Series



Load Range:

0 - 86 tons

Maximum Operating Pressure*:

21,750 psi / 1500 bar

* Maximum pressure varies, see specification table for details.



Tensioner Pumps

Electric, pneumatic and manual high-pressure tensioning pumps are available for use with Enerpac hydraulic tensioners.

Page: 239



Hoses and Fittings

High-pressure hoses and fittings for use with Enerpac tensioning systems are available.

Page: 325

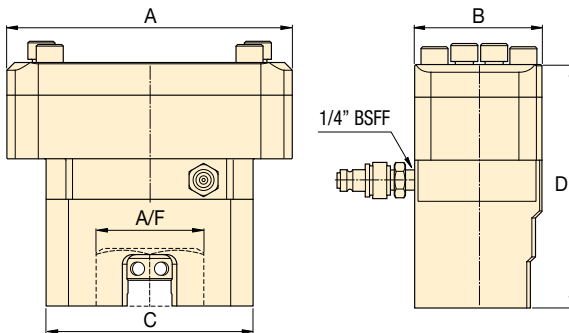

▼ SPECIFICATION TABLE

Bar Grade	Bolt Diameter		Bar Size Designation	Model Number	Nut A/F	Maximum Pressure	Hydraulic Pressure Area	Load Capacity	Stroke	Dimensions (in)				Wt. (lbs)	Min. Bolt Protrusion (in)
	(in)	(mm)								A	B	C	D		
75 ksi	1.38	35	#10	FTE7510S	2.00	17,400	4.82	41.9	0.39	6.69	3.23	5.59	5.81	18.19	7.87
	1.50	38	#11	FTE7511S	2.25	21,750	4.82	52.4	0.39	6.69	3.23	5.59	5.81	18.19	8.66
150 ksi	1.44	37	1.25	FTE150125S	2.25	17,400	7.86	68.4	0.39	8.74	3.90	6.34	8.01	41.67	9.45
	1.56	40	1.375	FTE150138S	2.50	21,750	7.86	85.6	0.39	8.74	3.90	6.34	8.01	40.81	9.06
8.8	1.42	36	36	FTE8836S	2.36	21,750	4.82	52.4	0.39	5.59	3.23	5.59	5.81	21.32	7.09

▼ HPT1500



HPT Series

Reservoir Capacity:

155 in³

Flow at Rated Pressure:

0.037 in³/stroke

Maximum Operating Pressure:

21,750 psi (1500 bar)



Ultra High-Pressure

These pumps operate at ultra high-pressure, use only the specified fittings and hoses designed for these pressures.

Page: **325**



Applications

The Enerpac HPT high-pressure Hand Pump is ideally suited for use with hydraulic bolt tensioning tools and hydraulic nuts.

Page: **239**

- Lightweight and portable high-pressure hand pump
- Two-speed operation displaces a larger volume of oil per stroke, reducing cycle times for many testing applications
- Includes a gauge and coupler for direct connection to Enerpac Bolt Tensioners
- Integrated relief valve set at 21,750 psi

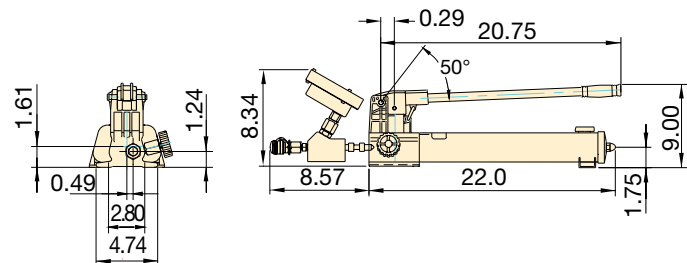

▼ 21,750 PSI ULTRA-HIGH PRESSURE PUMP

Pump Type	Usable Oil Capacity (in ³)	Model Number	Pressure Rating (psi)		Oil Displacement per Stroke (in ³)		High Pressure Oil Port with Female Coupler	Wt. (lbs)
			1 st stage	2 nd stage	1 st stage	2 nd stage		
Two Speed	155	HPT1500	200	21,750	0.99	0.037	1/4" BSPP + BR50	19

Ultra-High Pressure Hoses & Couplers

- **Hose Reel and Stand:** Stainless steel stand with 21,750 psi hoses from 98.42 up to 885.8 ft. lengths
- All hose reels are built up with multiple 98.42 ft. length hoses
- Wide offering of hoses and system components to complete your tensioning system
- Can be used for subsea fastening systems
- Hoses can be inter-connected in multi-tool set-ups using nipples, couplers, T-pieces and Y-Pipe assemblies

**HT,
B
Series**



Hose Length:
3.28 - 98.42 feet

Hose Reel & Stand:
98.42 - 885.8 feet

Maximum Operating Pressure:
21,750 psi (1500 bar)

21,750 PSI HOSE REEL & STANDS

Model Number		Stainless Steel Hose Reels with Stand (Hose with female half BR150 and male half BH150 couplers)
HT15000RS		Reel & Stand Assembly, No Fitting
HT15000HRS		Hose Reel & Stand, No Hose
HT15100HRS		Hose Reel & Stand, with 100 ft. hose
HT15200HRS		Hose Reel & Stand, with 200 ft. hose
HT15300HRS		Hose Reel & Stand, with 300 ft. hose
HT15400HRS		Hose Reel & Stand, with 400 ft. hose
HT15500HRS		Hose Reel & Stand, with 500 ft. hose
HT15600HRS		Hose Reel & Stand, with 600 ft. hose
HT15700HRS		Hose Reel & Stand, with 700 ft. hose
HT15900HRS		Hose Reel & Stand, with 900 ft. hose

21,750 PSI HOSES

Model Number	Hoses	Hose End 1	Hose End 2	Length (ft)
HT1503		1/4 BSPM 120° Cone	1/4 BSPM 120° Cone	3.28
HT1510		1/4 BSPM 120° Cone	1/4 BSPM 120° Cone	9.84
HT15100		1/4 BSPM 120° Cone	1/4 BSPM 120° Cone	98.42
HT1503HR *		BH150	BR150	3.28
HT1506HR *		BH150	BR150	5.90
HT1510HR *		BH150	BR150	9.84
HT1520HR *		BH150	BR150	20
HT15100HR *		BH150	BR150	98.42
HT1503RR *		BR150	BR150	3.28
HT1506RR *		BR150	BR150	5.90
HT1510RR *		BR150	BR150	9.84
HT1520RR *		BR150	BR150	20

* Includes dust caps

H = Male Nipple (BH150); R = Female Coupling (BR150)

21,750 PSI COUPLERS

Description (Includes dust caps)	Accessories	Complete Set	Female Half	Male Half
Quick Disconnect Coupler		B150	BR150	BH150
Quick Disconnect Coupler and Adaptor Kit		BW150AW	-	-
Quick Disconnect Blanking Coupler Set*		B150B	BR150B	BH150B

21,750 PSI T-PIECES

Model Number	shown HT15TPMMF	End 1	End 2	End 3
HT15TPMMF		1x BH150	1x BH150	1x BR150
HT15TPMMM		1x BH150	1x BH150	1x BH150

21,750 PSI Y-PIPE ASSEMBLIES

Model Number	shown HT1506YTPMMF	End 1 Hose	End 2 Hose	End 3 T-Pieces
HT1506YTPMMF		HT1506HR	HT1506HR	HT15TPMMF
HT1510YTPMMF		HT1510HR	HT1510HR	HT15TPMMF
HT1506YTPFMF		HT1506RR	HT1506RR	HT15TPMMM
HT1510YTPFMF		HT1510RR	HT1510RR	HT15TPMMM

Y-Pipe Assembly: 1+2 = Adaptor; 3 = Stainless Steel T with 1/4" BSPM;
4 = Male Nipple (BH150); 5 = Female Coupling (BR150); 6 = Hose

Tensioning Every Single Stud in a Joint Simultaneously



▲ *Multi-Stud Tensioning Set-Up.*

MULTI-STUD TENSIONERS

Enerpac Multi-Stud Tensioning (MST) systems are capable of tensioning every single stud in a joint simultaneously. By applying a predictable and accurate pre-load to all studs, problems associated with conventional bolt tightening techniques are avoided. Typical Enerpac Multi-Stud Tensioning applications include:

Manway, Hand Hole & Inspection Covers

MST systems are the fastest and most accurate means of loosening and tightening studs on Primary and Secondary Manway Covers, Hand-Hole and Inspection Ports in nuclear facilities. Using special ram areas and strong lightweight materials, the MST's reduce bolting time by as much as 75%.

Coolant Pump

A custom slimline tensioning system for a Nuclear Reactor Coolant Pump, using six equally spaced tensioners and tightening studs in four passes, has reduced bolting times by 25% and significantly increased tensioning accuracy.

Wind Turbine Blade Assembly

Using an Enerpac MST has allowed wind turbine blade assembly times to be reduced by approx. 65% while bolt load accuracy and consistency have improved, resulting in better joint life and reduced maintenance requirements. The MST, comprising four tool segments, is capable of simultaneously tensioning up to 88 bolts connecting a 125 ft. long blade to a bearing slew ring.

MST - Multi-Stud Tensioners

This tool can be custom designed, and built, for virtually any nuclear facility. We specialize in addressing difficult projects that demand accurate loads within tight space envelopes, while also seeking ease of operation and performance.

- Designed in segments enabling the operator to easily and quickly connect each segment to the joint and link together to provide simultaneous loading.
- Very accurate and fast closure system for large tensioning applications on pumps, valves, and steam generators, for example.
- For ease of handling on-site, Enerpac MST systems can be supplied with an integral lifting frame and trolley.



▲ *Multi-Stud Tensioner.*



▲ *Multi-Stud Tensioning application.*

Ultra High-Pressure Air Pump

▼ ATP1500



- General purpose, high-pressure air-driven pump unit for products requiring up to 21,750 psi hydraulic pressure
- Compact, lightweight, rugged steel frame for protection and easy handling
- Prelubricated pump element, does not require an air line lubricator
- Easily adjustable output pressure control
- Integrated and protected easy-to-read glycerine-filled gauge
- Safety relief-valve limits output pressure
- ATEX Certified

The ATP-series pump is tested and certified according to the Equipment Directive 94 / 9 / EC "ATEX Directive". The explosion protection is for equipment group II, equipment category 2 (hazardous area zone 1), in gas and/or dust atmospheres.

The ATP-series pump is marked with: Ex II 2 GD ck T4.

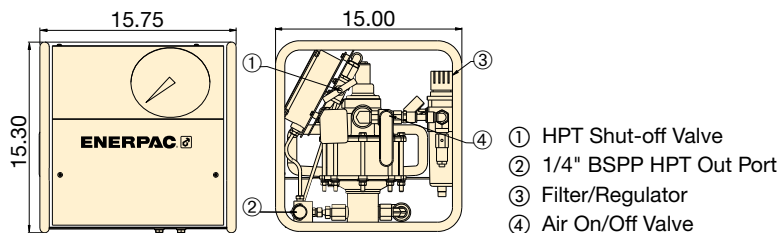

ATP Series



II 2 GD ck T4
IBExU 070/10



Reservoir Capacity:

1.0 gallon

Flow at Rated Pressure:

4 in³/min.

Maximum Operating Pressure:

21,750 psi (1500 bar)



Ultra High-Pressure

These pumps operate at ultra high-pressure, use only the specified fittings and hoses designed for these pressures.

Page: 325



Applications

The ATP-pump is ideally suited for use with hydraulic bolt tensing tools and hydraulic nuts.

Page: 239

OIL FLOW vs. PRESSURE

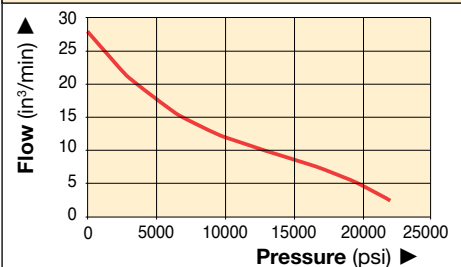

— Flow (in³/min) at 90 psi air input

21,750 PSI HIGH PRESSURE PUMP

Pump Type	Useable Oil Capacity (gal)	Model Number	Pressure Rating (psi)	Output Flow Rate at 0 psi (in ³ /min)	Output Flow Rate at 21,750 psi (in ³ /min)	Air Pressure Range (psi)	Air Consumption (sfcm)	Sound Level (dBA)	Wt. (lbs)
Two Speed	1.0	ATP1500	21,750	26	4	80-90	70	70	65

▼ ZUTP1500SB-H



Reliability, Power and Precision



Applications

The Enerpac ZUTP-Series electric pump is ideally suited for use with hydraulic bolt tensioning tools and hydraulic nuts.

Page: 239



Ultra-High Pressure

These pumps operate at ultra-high pressure, use only the specified fittings and hoses designed for these pressures.

Page: 325



Bolting Integrity Software

Visit www.enerpac.com to access our free on-line bolting software application and obtain information on tool selection, bolt load calculations and tool pressure settings. A combined application data sheet and joint completion report is also available.

Page: 416

- High-efficiency Universal Motor draws lower amps for superior performance in remote locations with low power quality
- Two-stage pump design provides high flow at low pressure for fast system fills and controlled flow at high pressure for safe and accurate operation
- Compact and lightweight design fits through tight openings and provides easy handling
- Panel mounted 6" pressure gauge, with polycarbonate cover, is set into the protective metal shroud for improved visibility and safety
- Easily accessible manual override valve to release pressure if power is lost
- Safety relief valve limits output pressure



◀ *The ZUTP1500 pump is rugged, lightweight, compact for tight openings, and delivers hassle-free operation of bolt tensioning in remote locations with up to two times the speed of competitive pumps.*

Electric Tensioning Pumps



ZUTP-Tensioning Pumps

The ZUTP-Series of pumps achieve high pressure without the need for an intensifier. This allows for low maintenance, resulting in less cost for the end-user.

ZUTP-S with Solenoid Valve

The ZUTP1500-S Series with pendant-operated solenoid valve is ideal for multiple bolt tensioning applications as it allows for single-person operation. The operator can pressurize and depressurize the tensioner directly from the pendant.

ZUTP Series



Reservoir Capacity:

1 gallon

Flow at Rated Pressure:

20.0 in³/min.

Motor Size:

1.7 hp

Maximum Operating Pressure:

21,750 psi

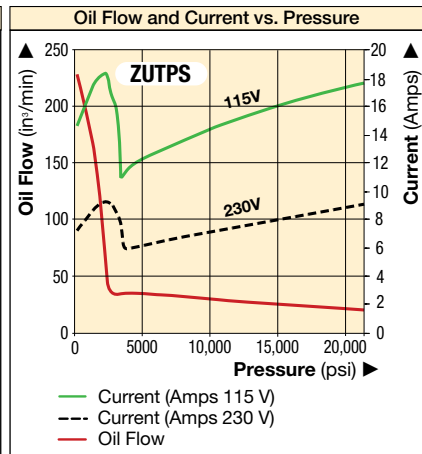
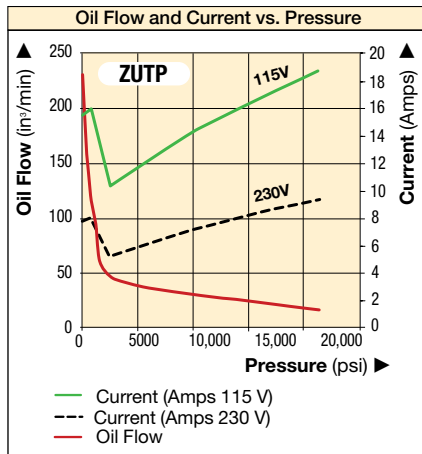

ZUTP

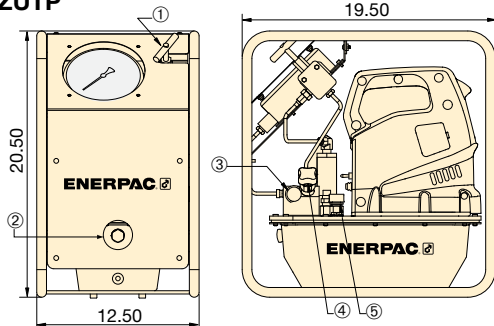

- ① Release Valve
- ② Sight Glass
- ③ Out Port
- ④ User Adjustable Relief Valve
- ⑤ Breather

ZUTPS

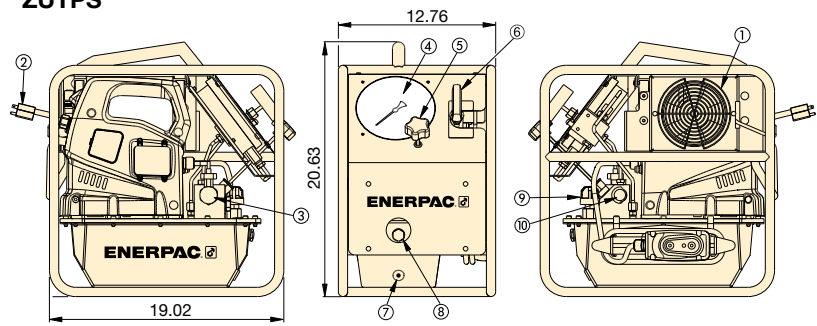

- ① Heat Exchanger (optional)
- ② Power Cord
- ③ Solenoid Dump Valve
- ④ Pressure Gauge
- ⑤ User Adjustable Relief Valve
- ⑥ Manual Release Valve
- ⑦ Oil Drain
- ⑧ Oil Level Sight Glass
- ⑨ Breather
- ⑩ Outlet Port with CEJN Coupler (116 Series)

Pump Type	Useable Oil Capacity (gal)	Valve Type	Model Number ¹⁾	Pressure Rating (psi)	Output Flow Rate at 0 psi (in ³ /min)	Output Flow Rate at 21,750 psi (in ³ /min)	Motor Electrical Specification (50 Hz)	Motor Size (hp)	Sound Level (dBA)	Wt. (lbs)
Two Speed	1.0	Solenoid	ZUTP1500SB	21,750	230	20	115 VAC, 1-ph	1.7	89	65
			ZUTP1500SE ²⁾				230 VAC, 1-ph ²⁾			
			ZUTP1500SI ³⁾				230 VAC, 1-ph ³⁾			
Two Speed	1.0	Solenoid	ZUTP1500SB-H ⁴⁾	21,750	230	20	115 VAC, 1-ph	1.7	89	75
			ZUTP1500SE-H ^{2) 4)}				230 VAC, 1-ph ²⁾			
			ZUTP1500SI-H ^{3) 4)}				230 VAC, 1-ph ³⁾			
Two Speed	1.0	Manual	ZUTP1500B	21,750	230	20	115 VAC, 1-ph	1.7	89	65
			ZUTP1500E ²⁾				230 VAC, 1-ph ²⁾			
			ZUTP1500I ³⁾				230 VAC, 1-ph ³⁾			

¹⁾ All models meet CE safety requirements and all TÜV requirements.
²⁾ European plug and CE EMC directive compliant.
³⁾ With NEMA 6-15 plug.
⁴⁾ Pumps come with factory installed heat exchangers

▼ From left to right: ATM4, ATM9, ATM2



- Enerpac ATM-Series tools rectify twist and rotational misalignment quickly, safely, and without the need for an external power source
- Appropriate for use on most ANSI, API, BS and DIN flanges
- No slings, hooks or lifting gear required
- Can be installed and used in any position (horizontally or vertically)
- Portable, lightweight design enables easy transport and use, even in remote locations
- Stays stable in position under full load
- Reduces set-up time: no need for chains, pulleys or rigs
- Safety strap helps provide secure operation
- Each ATM-model contains a tool and kit box

The Faster, Simpler and Safer Way to Align Flanges



Adjustable Reach

The highly adjustable reach of the wing and drop leg on the ATM4 and ATM9 allows precise alignment.



Gauge and Adaptor

The ATM9 includes P142 hand pump and HC7206C 6 ft. long hose. Enerpac recommend the use of the pressure gauge **GP10S** and gauge adaptor **GA4** for easy mounting of the gauge onto your system or use GA45GC Gauge Adaptor Assembly.



TFA-Series Wind Turbine Tower Flange Alignment Tools

The TFA Wind Turbine Tower Flange Alignment Tools have been developed to aid the alignment of large flanges on the inside of wind turbine towers during their assembly or installation.

Page: 356

▼ The compact ATM2 is actuated by simply hand turning the crank.



▼ The ATM9 is shown here with optional pressure gauge and gauge adaptor.



Flange Alignment Tools



Applications

Enerpac ATM-Series Tools help correct flange misalignment, and allow bolts to be placed into joints. This alignment takes place during pipework construction, or maintenance.

These tools provide pipe installers and maintenance personnel with some of the simplest, safest and most productive solutions available for flange alignment in the market today.

- ① Extendable wing provides usage on wide variety of flanges.
- ② Portable, light weight design enables easy transport and use.
- ③ Hand-adjustable base for easy positioning by a single operator.
- ④ Safety strap helps provide secure operation from a horizontal or vertical position.

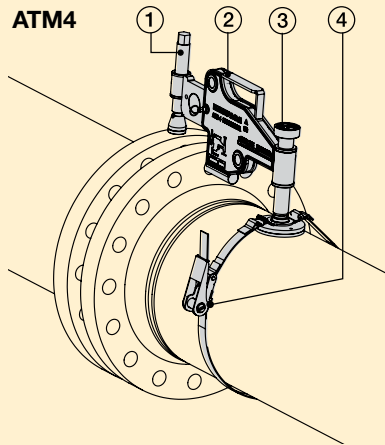

ATM Series



Minimum Bolt Size:

0.63 - 1.40 inches

Flange Wall Thickness:

0.55 - 9.00 inches

Maximum Lifting Force:

1 - 10 tons

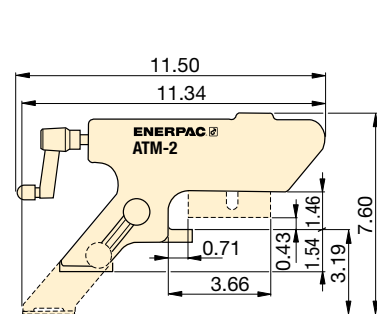

ATM2

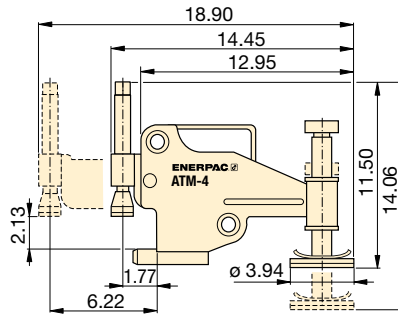

ATM4

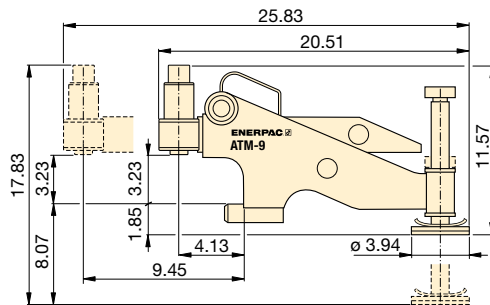

ATM9



Cylinder-Pump Sets

Hydraulic cylinders, jacks and lifting wedges can also be used to assist in pipe line positioning and aligning.

Page: 63



Pipe Flange Face Tool

The portable, hand powered tool FF120 makes even the hardest to reach pipe flanges resurfaceable in a safe and convenient way.

Page: 340

▼ The ATM-Series – the faster, simpler and safer way to align flanges.



Maximum Lifting Force (ton)*	Maximum Lifting Force (kN)*	Model Number	Minimum Bolt Size**		Flange Wall Thickness (max)		Wt. (lbs)
			(in)	(mm)	(in)	(mm)	
1	10	ATM2	0.63	16	0.55 - 3.29	14 - 82	3.5
4	40	ATM4	0.95	24	1.18 - 5.23	30 - 133	19
10	90	ATM9**	1.40	35,5	3.66 - 9.00	93 - 228	32

* At 10,000-psi maximum operating pressure.

** ATM9 includes an Enerpac hand pump and hydraulic hose (gauge and adaptor sold separately). ATM9 weight includes tool only.

▼ FSC14, FSM8 and FSH14 with Safety Blocks SB1



Practical, Portable and Lightweight



FSC14 with Integrated Hand Pump
 Powered by a built-in hydraulic hand pump, the FSC14 is a ready-to-use tool – no making or breaking hydraulic connections. This compact tool delivers 14 US tons of force and requires a clearance gap as small as 0.24 inch.



Stepped Blocks FSB1
 Use this pair of stepped blocks to increase wedge opening up to 3.16 in. (80 mm). Fits **FSC**, **FSH** and **FSM** models.



AM-Series Control Manifolds
 For simultaneously and even spreading of flange joints, 180° apart with FSH14.

152



Flange Maintenance Tools
 Secure-Grip flange spreading tools for application on flanges with a small gap.

Page: 352

- **Integrated wedge concept:** friction-free, smooth, parallel wedge movement eliminates flange damage and spreading arm failure
- **Unique interlocking wedge design:** no first step bending and risk of slipping out of joint
- **Requires very small access gap of only 0.24 inch (6 mm)**
- **Stepped spreader arm design:** each step can spread under full load
- **Few moving parts means durability and low maintenance**
- **Safety block SB1 included with FSC14, FSH14 and FSM8**
- **Ratchet spanner SW22 included with FSM8 mechanical spreader**
- **Single-acting cylinder included with FSH14 hydraulic spreader**



◀ Two FSH14 spreaders used simultaneously with Enerpac handpump, hoses and AM21 control manifold.

Flange Spreading Wedges



Flange Spreading Wedges

The flange spreading tools have been developed to aid and simplify the maintenance of flange joints. No longer will those tasked with separating flanges have to rely on using ropes and pulleys, podgers, tirsors, come-alongs or hammers – there is a safe, quick and effective alternative, the Enerpac range of

spreaders. These spreaders use mechanical and hydraulic principles for separating flanges and can spread small, medium or large flange joints. Tool selection is made on the basis of the access gap between the flange faces, the flange size and the required scope of work.

FSC, FSH, FSM Series



Tip Clearance / Maximum Spread¹⁾:
0.24 / 3.16 inches

Maximum Spread Force:
8 - 14 tons

Maximum Operating Pressure:
10,000 psi (FSH-14)

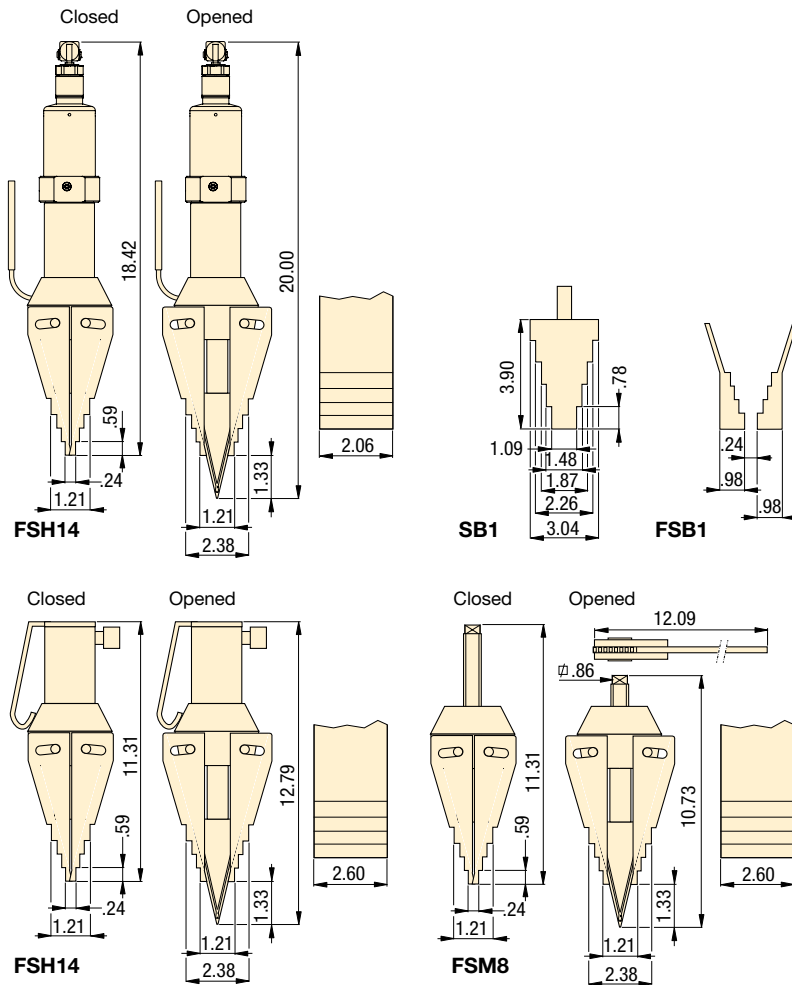

Safety Lanyard FSC1

Recommended safety accessory to compliment the safe hands-free bolting. Includes steel cable with carabiners.

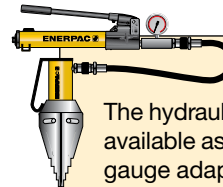

Tool Pump Sets

The hydraulic flange spreader is available as a set (pump, tool, gauge, gauge adaptor, couplers and hose) for your ordering convenience.

Spreader Model No.	Hand Pump Model No.	Set Model Number
FSH14	P392	STF14H

▼ Flange maintenance and joint separation with FSH14 Hydraulic Wedge Spreader.



Max. Spreading Force (ton)	Model Number	Tip Clearance (in)	Max. Spread ¹⁾ (in)	Type	Oil Capacity (in ³)	Wt. (lbs)
14	FSC14	0.24	3.16	Integral hydraulics	–	19.8
14	FSH14*	0.24	3.16	External hydraulics	4.76	15.7
8	FSM8	0.24	3.16	Mechanical	–	14.3

¹⁾ Using stepped blocks FSB1.

* Available as Tool Pump Set, see note on this page.

▼ Shown from left to right: NC3241, NC1019, NC1924



The Safest and Easiest Way to Remove Corroded and Frozen Nuts

- Compact and ergonomic design, easy to use
- Unique angled head allows flush access
- Two blade design (NC-D models) for time saving operation – nuts are split from two sides in one action
- Single-acting, spring return cylinder
- Heavy-duty chisels can be reground
- Nut Splitters include spare chisel, spare set screw and wrench used to secure the chisel
- A CR400 coupler is standard

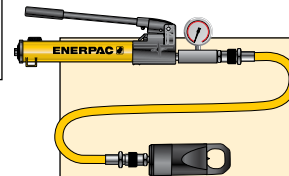

Tool-Pump Kits

Hydraulic Nut Cutters are available as sets (pump, tool, gauge, adaptor and hose) for your ordering convenience.

Hydraulic Nut Cutters are available as sets (pump, tool, gauge, adaptor and hose) for your ordering convenience.

Nut Splitter Model Number	Hand Pump Model Number	Nut Splitter Set Model Number
NC1924	P392	STN1924H
NC2432	P392	STN2432H
NC3241	P392	STN3241H

▼ Enerpac hydraulic nut splitters – the safest and easiest way to remove corroded and frozen nuts



High-Pressure Hoses

Enerpac offers a complete line of high-quality hydraulic hoses. To ensure the integrity of your system, specify only genuine Enerpac hydraulic hoses.

Page: 148



GA45GC Gauge Adaptor

Protect yourself from system overloading by simply ordering one part number for a pre-assembled gauge, adaptor block and coupler.

Page: 162

Single-Acting Hydraulic Nut Splitters



Frozen or Corroded Nuts

Often nuts are difficult to remove, while loosening using tightening tools is possible, it generally requires larger equipment and is time consuming.

The use of cutting torches or hammers and chisels can cause damage to the joint components, requires significantly longer setup and operational time, and can present a potential safety risk.

Hydraulic Nut Splitters

Nut splitting with the Enerpac Hydraulic Nut Splitters is the safest method. It takes less time and avoids costly damage to joint components.

The head design fitted with heavy-duty chisels permits the splitting of nuts on a wide variety of applications. With the two blade models nuts are split from two sides in one action.

NC, STN Series



Bolt Range:

0.31 - 1.88 inches

Hexagon Nut Range:

0.50 - 2.88 inches

Capacity:

5 - 90 tons

Maximum Operating Pressure:

10,000 psi

For Nut Splitter Model No.	Replacement Chisel Model Number	
	Moving	Static
NC1019	NCB1019	–
NC1924	NCB1924	–
NC2432	NCB2432	–
NC3241	NCB3241	–
NC4150	NCB4150	–
NC5060	NCB5060	–
NC6075	NCB6075	–
NC1924D	NCB1924	NCB1924D
NC2432D	NCB2432	NCB2432D
NC3241D	NCB3241	NCB3241D

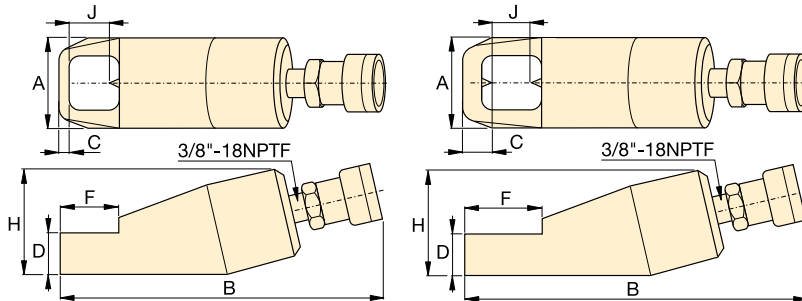

Single Blade Models (NC)

Double Blade Models (NC-D)

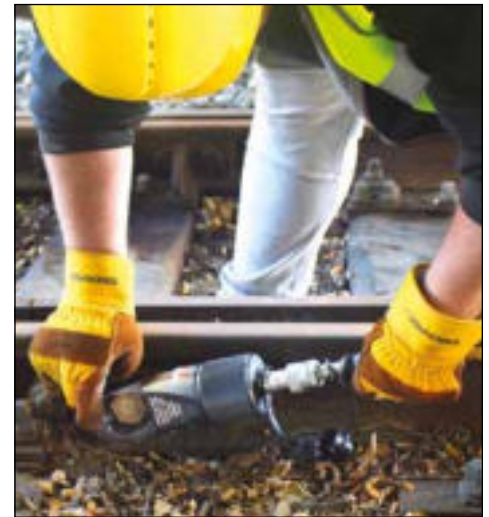

	Bolt Range (in)	Hexagon Nut Range (in)	Maximum Cutting Force (ton)	Oil Capacity (in ³)	Model Number	Dimensions (in)							Weight (lbs)
						A	B	C	D	F	H	J	
	0.31-0.50	0.50-0.75	5	0.92	NC1019	1.57	6.69	0.27	0.75	1.10	1.89	0.83	1.8
	0.50-0.63	0.75-0.94	10	1.22	NC1924 *	2.17	7.52	0.32	1.02	1.57	2.44	0.98	4.4
	0.63-0.88	0.94-1.13	15	3.66	NC2432 *	2.52	8.74	0.39	1.22	2.01	2.83	1.30	6.6
	0.88-1.13	1.13-1.56	20	4.88	NC3241 *	2.95	9.61	0.67	1.42	2.60	3.46	1.69	9.7
	1.13-1.38	1.56-2.00	35	9.46	NC4150	3.70	11.34	0.83	1.77	2.91	4.13	2.13	18.0
	1.38-1.50	2.00-2.25	50	14.64	NC5060	4.17	12.52	0.91	2.13	3.54	5.04	2.36	26.0
	1.50-1.88	2.38-2.88	90	30.00	NC6075	6.14	15.47	1.02	2.83	4.33	7.13	3.15	75.1
	0.50-0.63	0.75-0.94	10	1.22	NC1924D	2.13	6.61	0.87	0.98	1.97	2.60	1.02	8.4
	0.63-0.88	0.94-1.13	15	3.66	NC2432D	2.52	10.83	0.98	1.22	2.56	3.07	1.30	11.9
	0.88-1.13	1.13-1.56	20	4.88	NC3241D	3.03	12.00	1.22	1.46	3.15	3.54	1.69	15.9

Ordering Notes: Maximum allowable hardness to split is HRC-44. Not to be used on square nuts or stainless steel.

* Available as Tool-Pump set, see note on page 334.

▼ Shown from left to right: NSH1927, NSC1927



Designed to Meet the Challenges of Bolted Pipeline Flange Joints



NSC-Series Nut Splitters with Integral Hand Pump

Powered by a built-in hydraulic hand pump, the NSC-Series are a ready-to-use tool – no need for hose, separate hand pump or couplings.



Carrying Case

Nut splitters (up to NSH6575) come in a carry case for portability and easy storage.



Safety Lanyard FSC1

Standard Safety Lanyard with each nut splitter. Includes steel cable with carabiners.

- NSC-Series with built-in small hand pump – useful for subsea applications and working at heights
- Quick and easy cutting tip replacement
- Drop-tested revolving anchor point and safety lanyard
- Revolving composite handle for vibration and shock isolation
- Nut Splitters include set of hexagon keys and following spare parts:
 - cutting tip
 - tip retention screw
 - spare alignment screw
- CR400 female half coupler is standard (NSH)

▼ *The sharp cutting tip and opposing convex reaction point encourages more efficient splitting by spreading the nut open rather than squashing the nut onto the stud. This makes it easier to rotate the nut for the second cut.*

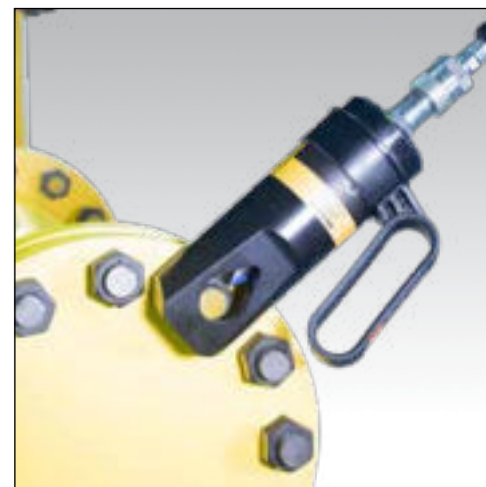
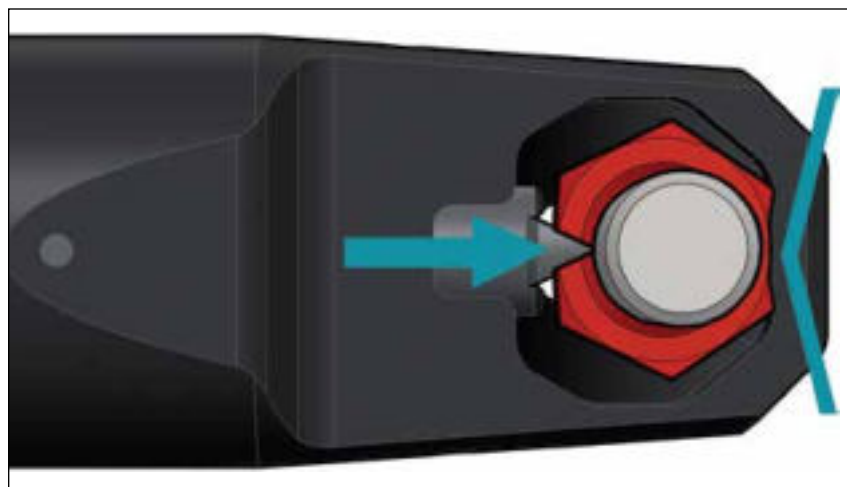

Single-Acting Integral & Hydraulic Nut Splitters



Frozen or Corroded Nuts

Often nuts are difficult to remove, while loosening using tightening tools is possible, it generally requires larger equipment and is time consuming.

The use of cutting torches or hammers and chisels can cause damage to the joint components, requires significantly longer setup and operational time, and can present a potential safety risk.

Hydraulic Nut Splitters

Nut splitting with the Enerpac Hydraulic Nut Splitters is the safest method. It takes less time and avoids costly damage to joint components. The head design fitted with heavy-duty chisels permits the splitting of nuts on a wide variety of applications. With the two blade models nuts are split from two sides in one action.

NSC, NSH Series



Bolt Range:

1/2 - 1 7/8 inches

Hexagon Nut Range:

0.75 - 2.95 inches

Capacity:

12 - 50 tons

Maximum Operating Pressure:

10,000 psi (NSH-Series)

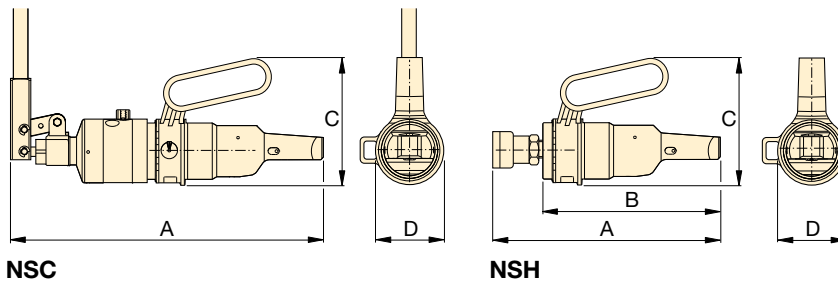

NSC

NSH



High-Pressure Hoses

Enerpac offers a complete line of high-quality hydraulic hoses. To ensure the integrity of your system, specify only genuine Enerpac hydraulic hoses.

Page: 148

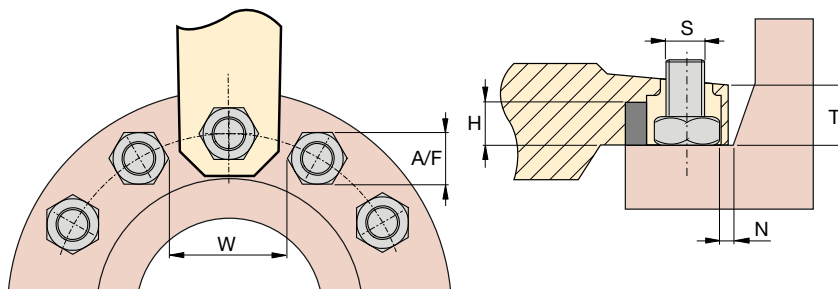

Joint Separation Tools

Flange Spreaders (FSC, FSH, FSM-Series) provide quick and easy joint separation using hydraulic or mechanical force.

Page: 332

▼ NUT SPLITTER SPECIFICATIONS

Bolt Range	Hexagon Nut Range	Maximum Cutting Force	Oil Capacity	Model Number	Nut Splitter Type	Dimensions (in)								Wt. (lbs)	Cutting Tip Service Kit Model No.	
						A	B	C	D	H max.	N min.	S max.	T			W min.
1/2 - 5/8	0.75 - 1.06	12	—	NSC1927	Integral pump	13.9	—	6.0	3.2	0.71	0.45	0.96	1.04	2.11	12.8	NSH1927CTK
3/4 - 7/8	0.94 - 1.26	15	—	NSC2432		14.6	—	6.0	3.2	0.98	0.35	1.04	1.26	2.26	13.9	NSH2432CTK
1/2 - 5/8	0.75 - 1.06	12	2.8	NSH1927	Hydraulic	10.1	8.4	6.0	3.2	0.71	0.45	0.96	1.04	2.11	7.7	NSH1927CTK
3/4 - 7/8	0.94 - 1.26	15	2.8	NSH2432		10.4	8.7	6.0	3.2	0.98	0.35	1.04	1.26	2.26	8.8	NSH2432CTK
7/8 - 1 1/8	1.42 - 1.81	20	4.9	NSH3646		11.4	9.4	6.7	3.7	1.34	0.63	1.53	1.73	3.20	15.2	NSH3646CTK
1 1/4 - 1 5/8	2.00 - 2.56	36	14.0	NSH5065		14.8	12.7	8.3	7.3	1.77	0.90	1.93	2.05	4.25	24.0	NSH5065CTK
1 5/8 - 1 7/8	2.56 - 2.95	50	20.0	NSH6575		15.6	13.6	8.7	7.9	2.15	1.06	2.40	2.56	5.31	54.0	NSH6575CTK

Ordering Notes: Maximum allowable hardness to split is ASTM A194 Gr 2H. Not to be used on square nuts or stainless steel.

▼ Shown: NSH31 with NSPH3, NSH41 with NSPH4



Ex II 2G c T6

- Designed to fit standard BS/ANSI flanges
- Blade positioning scale to eliminate bolt damage
- Adjustable cutting depth
- Ergonomically designed and positioned handle
- Interchangeable power heads with cutting blade
- Single-acting spring return power head (NSPH)
- Double-acting power head (NSPH-D):
– for subsea operation
- Nut splitters include spare chisel, spare set screw and wrench used to secure the chisel
- CR400 female half coupler standard on NSPH
- CR400 + CH604 couplers standard on NSPH-D

ATEX certified

- All NSH-tools are CE - ATEX certified

Versatile, reliable and trouble-free operation



Blade Positioning Scale

The power head can be adjusted to preset the blade cutting distance in order to prevent damage to the bolt thread as the nut is cut.

The blade positioning scale can be used with the following bolt and nut forms:

- Unified bolt threads (UN) with heavy series hexagon nuts
- Metric bolt threads (M) with standard series hexagon nuts



Steel Hand Pumps

The **P80** and **P84** two-speed hand pumps are ideal to operate nut splitters. The P84 can be used to power the double-acting tools.

Page: 88



High-Pressure Hoses

Enerpac offers a complete line of high-quality hydraulic hoses. To ensure the integrity of your system, specify only genuine Enerpac hydraulic hoses.

Page: 148

Single- and Double-Acting Hydraulic Nut Splitters



Hydraulic Nut Splitters

These Hydraulic Nut Splitters are the ideal tools for removing seized and corroded nuts, eradicating the need for unsafe grinding or flame cutting.

They are designed with a single acting spring return cylinder and boast a 360 degree rotation, lockable handle improving operator safety.

The heavy-duty blades can also be easily removed to enable replacement blades to be fitted.

Operator Safety

To improve operator safety an ergonomic, adjustable handle is available which can be easily fitted to the Nut Splitter.

This lightweight, durable accessory can prevent injuries such as trapped fingers by eliminating the need to hold the tool itself.

ATEX Certified: Ex II 2 G c T6

These Nut Splitters are tested and certified to conform to the 94/9/EC "ATEX Directive".

The explosion protection is for Equipment Group II, Equipment Category 2 (Hazardous Zone Area 1) in Gas and/or Dust atmospheres.

NSH Series



Bolt Range:

1¾ - 3½ inches

Hexagon Nut Range:

2¾ - 5⅜ inches

Maximum Operating Pressure:

10,000 psi

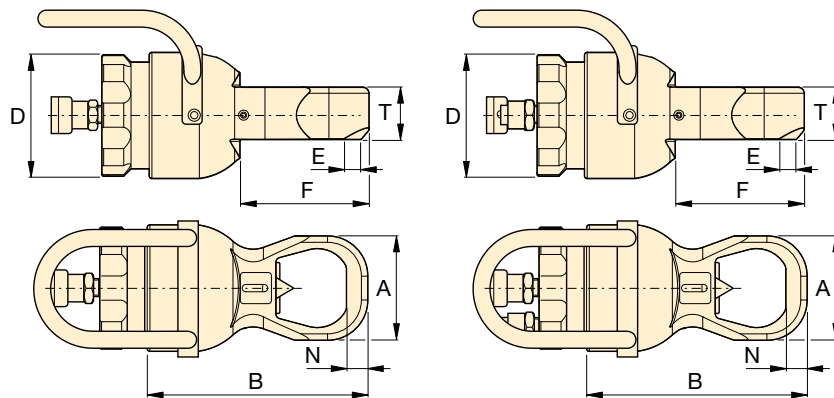
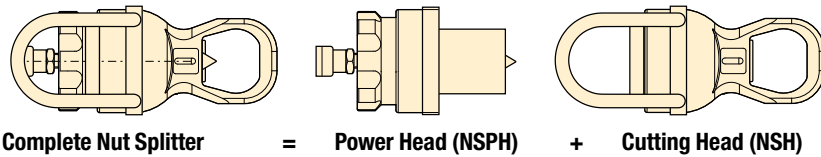

NSPH + NSH

NSPH-D + NSH



Joint Separation Tools

Flange Spreaders (FSC, FSH, FSM-Series) provide quick and easy joint separation using hydraulic or mechanical force.

Page: 332

For Power Head Model No.		Cutting Tip Service Kit Model No.
NSPH3	NSPH3D	NSPH3CTK
NSPH4	NSPH4D	NSPH4CTK

▼ NUT SPLITTER SPECIFICATIONS

Bolt Range (in)	Hexagon Nut Range A/F (in)	Maximum Cutting Force (ton)	Oil Capacity (in ³)	Model Numbers Nut Splitter Components				Dimensions (in)							Weight Cutting + Power Head (lbs)	
				Cutting Head	Wt. (lbs)	Power Heads		Wt. (lbs)	A	B	D	E	F	N		T
1¾ - 2	2¾ - 3⅛	115	33.5	NSH31	44.1	NSPH3	NSPH3D	48.5	5.2	12.1	7.5	0.3	7.4	1.1	3.2	92.6
1¾ - 2¼	2¾ - 3½	115	33.5	NSH32	46.3	NSPH3	NSPH3D	48.5	5.9	12.7	7.5	0.6	7.9	1.2	3.2	94.8
1¾ - 2½	2¾ - 3¾	115	33.5	NSH33	48.5	NSPH3	NSPH3D	48.5	6.3	13.0	7.5	0.4	7.9	1.3	3.2	97.0
1¾ - 2¾	2¾ - 4¼	115	33.5	NSH34	48.5	NSPH3	NSPH3D	48.5	6.8	13.5	7.5	0.4	8.0	1.4	3.2	97.0
2¾ - 3	4¼ - 4⅝	195	67.0	NSH41	69.9	NSPH4	NSPH4D	83.8	7.4	14.5	9.3	0.2	9.1	1.4	4.4	153.7
2¾ - 3½	4¼ - 5⅜	195	67.0	NSH42	95.9	NSPH4	NSPH4D	83.8	8.6	15.5	9.3	0.1	9.7	1.4	4.4	179.7

Ordering Notes: Maximum allowable hardness to split is ASTM A194 Gr 2H. Not to be used on square nuts or stainless steel.

▼ FF120



- Refacing made easy — hand-operated machine tool can be set up anywhere without the need for air, electric or hydraulic power support
- Lightweight and portable — easily transported to remote locations for increased productivity
- Adjustable cutting range for flange diameters between 1-12 inches [25,4-304,8 mm]
- Interchangeable collets for ID mounting range from 1-6 inches allowing the user to work on many different flanges with minimal time between set-ups
- Interchangeable lead screws suitable for refacing damaged raised-face (RF) or flat-face (FF) joint flanges
- Tool body with expanding collets centers itself providing real concentric operation

Safe, Efficient and Accurate Refacing of Flat Pipe Flange Surfaces



Complete In-Wheeled Carrying Case

The FF120 comes as portable set 33 lbs (15 kg). Can be transported,

easy set-up and operated by a single technician. **Set includes:**

- **FFL**-kit with locators, O-Rings and extensions
- **FSS**-kit with feed screw and nut 1/2"-20 UN for surface roughness Ra 64 - 96 µin.
- **FSF**-kit with feed screw and nut 1/2"-11 UNF for surface roughness Ra 125 - 250 µin.



Joint Separation Tools FSC, FSH and FSH-Series

Parallel wedge spreaders provide quick and easy joint separation using hydraulic or mechanical force.

Page: 332



Flange Alignment Tools

The ATM-Series provide safe and high-precision flange alignment tools that fit most commonly used ANSI, API, BS and DIN flanges.

Page: 330



Controlled Tightening and Loosening

Use Enerpac Bolting Tools to seal the joint to the precise torque or tension required: torque multipliers, torque wrenches and hydraulic bolt tensioners.

Page: 239

▼ The Enerpac FF120 used to face a pipe flange.



Quick Face, Mechanical Flange Face Tool



Mechanical Flange Face Tool

Portable, hand powered tool makes even the hardest to reach pipe flanges resurfaceable in a safe and convenient way.

Makes Refacing Easy

A simple and cost effective solution – the FF120 turns a two man operation with heavy equipment, compressors and portable generators into a one man job.

The FF120 has interchangeable lead screws that make it suitable for resurfacing damaged flat-faced, raised-face or lens-ring joint flanges to the high safety standards required.

FF120 is not suitable for lens-ring joint flanges or ring type joint (RTJ) flanges.

After selecting the correct lead screw for the operation, the tool body is inserted in the pipe end and centres itself with adjustable locators to provide real concentric operation.

The tool arm is then rotated by hand using a worm-gear mechanism to provide a perfect spiral “gramophone” finish.

The tool can be adjusted with a calibrated slide to define cut depth and the correct finish.

Surface Finish and Accuracy

A serrated finish with 30-55 grooves per inch and a resultant roughness of between Ra 125-492 micro inches (3,2-12,5 µm).

The FF120 has same precision and quality of finish as a lathe.

Cost-effective Solution

Small and portable enough to be a permanent addition to your equipment range, Enerpac’s FF120 is the perfect solution to all of your small diameter facing problems.

For more portable machining tools, see page 379.

FF Series



Pipe Flange Cutting Diameter Range:

1 - 12 inch (25-305 mm)

Internal Pipe Mounting Diameter Range:

1 - 6 inch (25-152 mm)

Average Roughness:

125 - 492 µin (3,2-12,5 µm)



- 1 Hand-operated cold work tool – no need for external power and hot work permits.
- 2 Calibrated cross slide for accurate cutting control.
- 3 Adjustable cutting head for reface of flat flange surfaces of pipes with flange OD facing range ϕ 1-12 inch [25,4-304,8 mm].
- 4 Interchangeable lead screws enable selection of surface finish between Ra 125-492 µin.
- 5 Utilizes standard 3/8 inch or 10 mm tool steel.
- 6 Range of interchangeable collets allow the tool to accommodate ϕ 1 - 6 inch [25,4 - 152,4 mm] pipe ID.
- 7 Tool body with expanding collets centers in the bore ensuring concentric and accurate set-up.

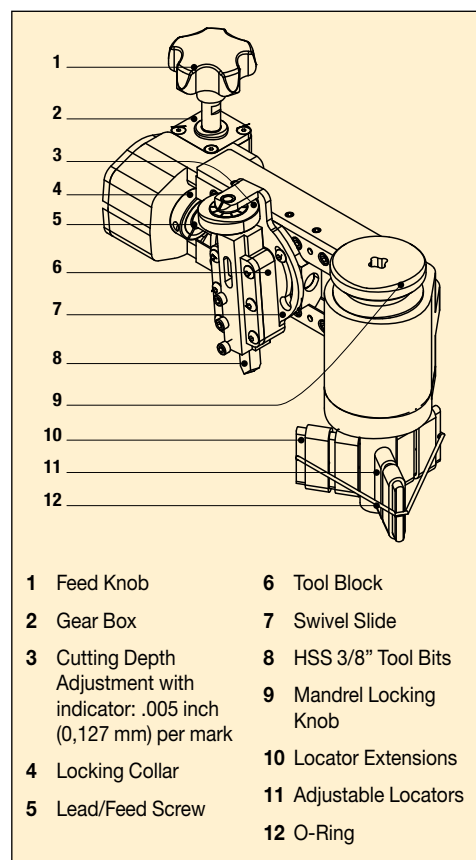

- | | |
|--|------------------------|
| 1 Feed Knob | 6 Tool Block |
| 2 Gear Box | 7 Swivel Slide |
| 3 Cutting Depth Adjustment with indicator: .005 inch (0,127 mm) per mark | 8 HSS 3/8" Tool Bits |
| 4 Locking Collar | 9 Mandrel Locking Knob |
| 5 Lead/Feed Screw | 10 Locator Extensions |
| | 11 Adjustable Locators |
| | 12 O-Ring |

Dimensions shown in inches.

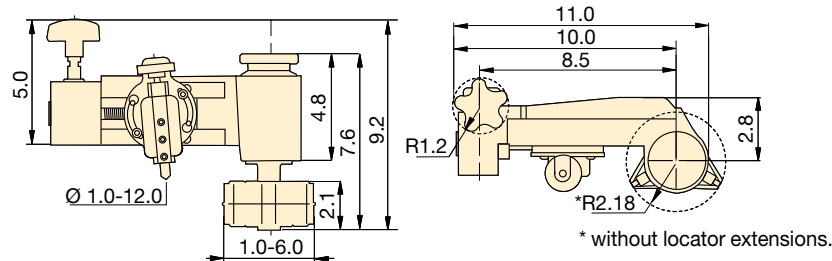

TOOL SELECTION CHART

Pipe Flange Cutting Diameter Range		Internal Pipe Mounting Diameter Range		Cutting Result Roughness (Ra µ)		Model Number	Wt. (lbs)
(in)	(mm)	(in)	(mm)	(in)	(m)		
1.0 - 12.0	25,4 - 304,8	1.0 - 6.0	25,4 - 152,4	125 - 492	3,2 - 12,5	FF120	15

▼ The Enerpac FF120 Quick Face has same precision and quality of finish as powered machines.



The Equalizer range of patented flange spreading tools have been developed to aid and simplify the maintenance of flange joints. No longer will those tasked with separating flanges have to rely on using ropes and pulleys, podgers, tirsors, come-alongs or hammers – there is a safe, quick and effective alternative, the Equalizer range of

SWi Flange Spreading Wedges

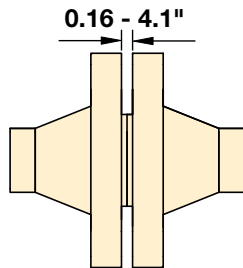

An innovative flange spreading wedge for use on small, medium or large flange joints with a minimum access gap of 0.16 inch. The SWi range includes ATEX approved options.

The SWi range has set the new standard for spreading flange joints powerfully, efficiently, effectively and safely. The tools offer the following features and benefits:

- Wider spreading - using the Standard Stepped Block accessories means the SWi range offers up to 30% more flange spreading distance than a traditional SW tool.
- Unrivalled power - the tools now offer up to 27 ton of spreading force when used in pairs, which provides additional confidence when spreading.
- Narrower jaws - the SWi5TE tools are only 1.97 inches wide to help them fit more easily between flange bolts.
- Fully rotational handle – the handle swivels 360° around the wedge head, so that the SWi tools can be used comfortably in all orientations.
- Easier maintenance – end-users will appreciate the ease with which the tools can be maintained. The supplied hex-key and a two-step process is all that's required to disassemble and reassemble the tools.
- No pinch points – the SWi range of tools has been engineered to overcome finger pinch-points.

spreaders. These spreaders use mechanical and hydraulic principles for separating flanges and can spread small, medium or large flange joints. Tool selection is made on the basis of the access gap between the flange faces, the flange size and the required scope of work.

MG Flange Spreading Tool

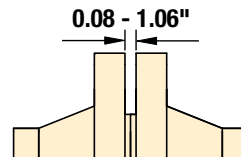

A mechanical tool for small diameter, low pressure flanges with a minimum access gap of 0.08 inch.

For use on smaller, lower pressure flange joints, this portable and flexible tool can be assembled in two alternative configurations that gives it twice the application range from one tool. The tool is locked onto the flange joint by the spreading bar preventing the risk of it falling from the flange joint.

SG Flange Spreading Tools

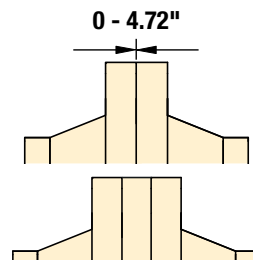

A unique flange spreader that is ideal for situations where there is no access gap or where there is a spacer, a wafer or butterfly valve positioned between the flanges.

Unique Secure-Grip tools spread by locking into the flange bolt holes and pulling the mating flanges away from each other, the Secure Grip flange spreaders are locked on to the flanges when under load making them arguably the world's safest flange spreading tools.



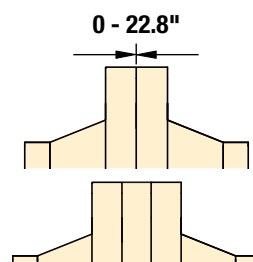







VC Valve Change-Out Tools



Using the same technology as the SG flange spreaders, the VC range has been developed for valve removal applications.

The VC Range of Valve Change-Out tools has been developed to assist in the removal of valves, spades/spacers or gaskets from large flange joints. The span of the tool is longer than a standard Secure-Grip Flange Spreader and is adjustable to enable the tool to operate in a range of applications.

Flange Maintenance Tools – Overview

Capacity (US tons)	Spreading Distance (inches)	Tool Type and Function	Series		Page
8.7 - 27	0.16 - 4.1	Flange Spreading Tools and Kits Flange Spreading Wedges	SWi		344 ▶
15.7 - 27	0.24 - 4.1	Flange Spreading Tools and Kits Flange Spreading Wedges, ATEX Certified	SWi		346 ▶
4.2 - 16.9	0 - 4.53	Flange Spreading Tools and Kits Hydraulic and Mechanical	SG		348 ▶
20.2 - 28.1	0 - 4.72	Flange Spreading Tools and Kits Hydraulic	SG		350 ▶
11.2	0 - 22.8	Flange Spreading Tools and Kits Secure-Grip Valve Change-Out Tools, Hydraulic	VC		352 ▶
7.6	0.08 - 1.06	Flange Spreading Tools and Kits Mechanical	MG		354 ▶
11.2	22.4 - 0	Flange Pulling Tools Hydraulic	FC		355 ▶
4.5 - 30.3	1.7 - 2.6	Flange Alignment Tools and Kits Wind Turbine Tower Flange Alignment Tools Hydraulic and Mechanical	TFA		356 ▶
18 - 67 in ³ 2-Speed	–	Hydraulic Sealed Hand Pumps Standard and ATEX-Certified	HP		357 ▶
6.5 - 20 ft	–	Hydraulic Hoses Standard and ATEX-Certified	144 302		357 ▶

▼ SWi5TI-S



SWi Series

FLANGE SPREADING WEDGES

Spreading Force:

8.7 - 27 tons

Spreading Distance:

0.16 - 4.1 inches

Maximum Operating Pressure:

10,000 psi *

* Only relevant for hydraulic tools



CAUTION

A minimum of two Flange Spreading Tools must be used when opening flange joints.

This will enable the operator to maintain an equal spreading distance across the flange faces.

- Practical, portable and lightweight
- Revolving handle to aid horizontal or vertical spreading
- Removable handle for improved access
- No finger pinch point
- Increased step-depth on upper steps
- Safety lanyard length, 39 inches
- Forged key components for strength and reliability
- Rapid disassembly and assembly
- Narrow jaw teeth – improved tool wear

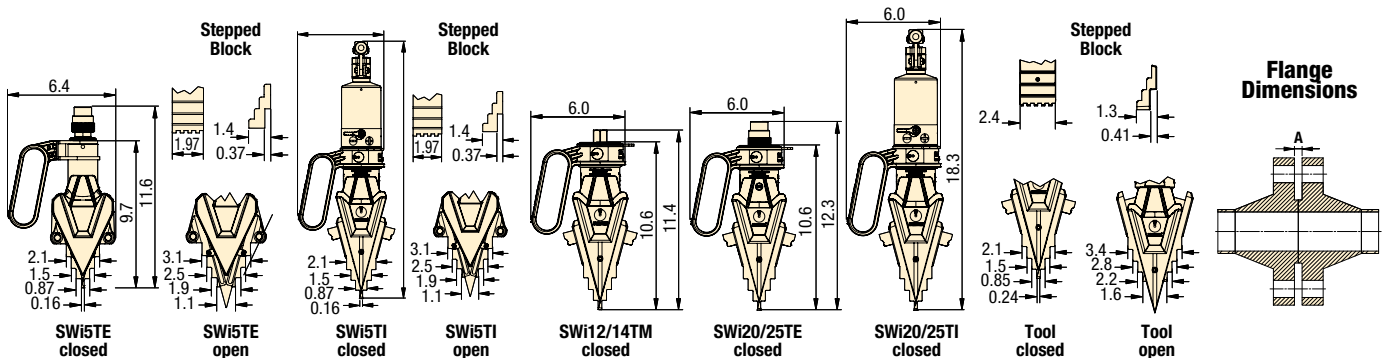

Model Number	Type	Maximum Spreading Force Per Tool (ton)	Spreading Distance Maximum * (in)	Flange Dimensions Minimum Access Gap A (in)	Jaw Width (in)	Tool Weight (lbs)	Kit Weight (lbs)	Case Dimensions (in)	Tool Number
SWi5TE-S	External Hydraulic	8.7	4	0.16	1.97	11.4	19.1	22.8 x 13.4 x 7.1	SWi5TE
SWi5TE-T	External Hydraulic	8.7	4	0.16	1.97	11.4	31.7	22.8 x 13.4 x 7.1	SWi5TE
SWi5TI-S	Integral Hydraulic	8.7	4	0.16	1.97	15.4	23.1	22.8 x 13.4 x 7.1	SWi5TI
SWi12/14TMSTDSPB	Mechanical	15.7	4.1	0.24	2.4	13.7	28.7	22.8 x 13.0 x 6.5	SWi12/14TM
SWi20/25TEMINSBPB	External Hydraulic	27	4.1	0.24	2.4	14.1	25.6	22.8 x 13.0 x 6.5	SWi20/25TE
SWi20/25TESTDSPB	External Hydraulic	27	4.1	0.24	2.4	14.1	45.6	36.2 x 19.7 x 8.1	SWi20/25TE
SWi20/25TEMAXSPB	External Hydraulic	27	4.1	0.24	2.4	14.1	72.8	36.2 x 19.7 x 8.1	SWi20/25TE
SWi20/25TISTDSPB	Integral Hydraulic	27	4.1	0.24	2.4	18.7	20.4	22.8 x 13.0 x 6.5	SWi20/25TI

* Using stepped blocks.

Flange Spreading Tools

SWi5TE - Hydraulic Flange Spreading Wedge

SWi5TE-S - SWi5TE S Kit



- 1 x SWi5TE Flange Spreading Tool
- 1 x Standard Safety Block
- 1 x Lanyard
- 1 x Moulded Plastic Carry Case with Protective Foam Inserts

SWi5TE-T - SWi5TE T Kit



- 2 x SWi5TE Flange Spreading Tools
- 2 x Standard Safety Blocks
- 2 x Lanyards
- 1 x Moulded Plastic Carry Case with Protective Foam Inserts

1640016-01 - SWi5TE Stepped Block Kit



- 1 x Pair of SWi5TE Stepped Blocks
- 2 x M6 CSK Hex Screw
- 2 x Retaining Washer
- 1 x SWi5TE Large Safety Block
- 2 x Hex Key

SWi12/14TM - Mechanical Flange Spreading Wedge

SWi1214TMSTDSPB - SWi12/14TM STD Kit



- 1 x SWi12/14TM Flange Spreading Tool
- 1 x Torque Wrench with 22 mm Socket
- 1 x Set of Safety Blocks
- 1 x Pair of Stepped Blocks
- 1 x Lanyard
- 1 x Hex Key
- 1 x Moulded Plastic Carry Case

SWi20/25TE - Hydraulic Flange Spreading Wedge

SWi2025TEMINSBPB - SWi20/25TE MIN Kit



- 1 x SWi20/25TE Flange Spreading Tool
- 1 x Set Safety Blocks
- 1 x Pair of Stepped Blocks
- 1 x Lanyard
- 1 x Hex Key
- 1 x Moulded Plastic Carry Case

SWi2025TESTDSPB - SWi20/25TE STD Kit



- 1 x SWi20/25TE Flange Spreading Tool
- 1 x 10,000 psi Hydraulic Hose, 6.5' with 90° Elbow
- 1 x 10,000 psi HP350S Single-Port Sealed Hand Pump with Gauge
- 1 x Set Safety Blocks
- 1 x Pair of Stepped Blocks
- 1 x Lanyard
- 1 x Hex Key
- 1 x Moulded Plastic Carry Case

SWi2025TEMAXSPB - SWi20/25TE MAX Kit



- 2 x SWi20/25TE Flange Spreading Tools
- 2 x 10,000 psi Hydraulic Hoses, 6.5' with 90° Elbow
- 1 x 10,000 psi HP550D Twin-Port Sealed Hand Pump with Gauge
- 2 x Set Safety Blocks
- 2 x Pair of Stepped Blocks
- 2 x Lanyards
- 2 x Hex Keys
- 1 x Moulded Plastic Carry Case

SWi5TI - Integral Hydraulic Flange Spreading Wedge

SWi5TI-S - SWi5TI S Kit



- 1 x SWi5TI Flange Spreading Tool
- 1 x Standard Safety Block
- 1 x Lanyard
- 1 x Moulded Plastic Carry Case with Protective Foam Inserts

1640016-01 - SWi5TE Stepped Block Kit



- 1 x Pair of SWi5TE Stepped Blocks
- 2 x M6 CSK Hex Screw
- 2 x Retaining Washer
- 1 x SWi5TE Large Safety Block
- 2 x Hex Key

SWi20/25TI - Integral Hydraulic Flange Spreading Wedge

SWi2025TISTDSPB - SWi20/25TI STD Kit



- 1 x SWi20/25TI Flange Spreading Tool
- 1 x Set of Safety Blocks
- 1 x Pair of Stepped Blocks
- 1 x Lanyard
- 1 x Hex Key
- 1 x Carry-Strap
- 1 x Moulded Plastic Carry Case

▼ SWi20/25TEEX



ATEX
CERTIFIED



SWi Series

ATEX CERTIFIED FLANGE SPREADING WEDGES

Spreading Force:

15.7 - 27 tons

Spreading Distance:

0.24 - 4.1 inches

Maximum Operating Pressure:

10,000 psi *

* Only relevant for hydraulic tools

- ATEX certified
- Practical, portable and lightweight
- Revolving handle to aid horizontal or vertical spreading
- Removable handle for improved access
- No finger pinch-point
- Increased step-depth on upper steps
- Safety lanyard length, 39 inches
- Forged key components for strength and reliability
- Rapid disassembly and assembly
- Narrow jaw teeth – improved tool wear



CAUTION

A minimum of two Flange Spreading Tools must be used when opening flange joints.

This will enable the operator to maintain an equal spreading distance across the flange faces.

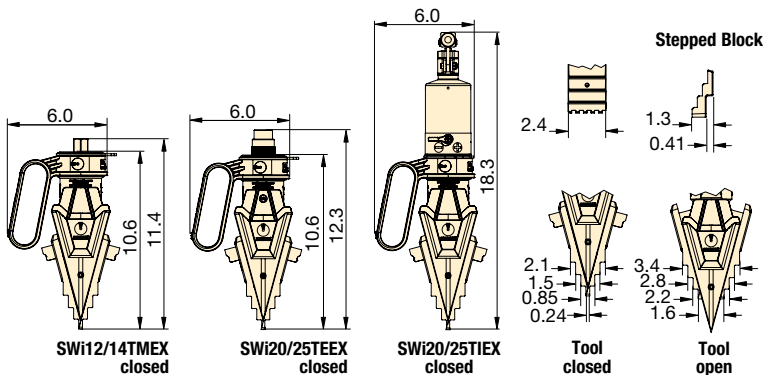

Flange Dimensions

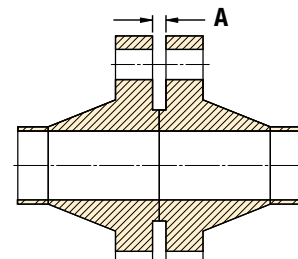

Model Number	Type	Maximum Spreading Force Per Tool (ton)	Spreading Distance Maximum * (in)	Flange Dimensions	Jaw Width (in)	Tool Weight (lbs)	Kit Weight (lbs)	Case Dimensions (in)	Tool Number
				Minimum Access Gap A (in)					
SWi1214TMSTDEX	Mechanical	15.7	4.1	0.24	2.4	13.7	37.5	22.8 x 15.7 x 7.1	SWi12/14TMEX
SWi2025TEMINEX	External Hydraulic	27	4.1	0.24	2.4	14.1	33.1	22.8 x 15.7 x 7.1	SWi20/25TEEX
SWi2025TESTDEX	External Hydraulic	27	4.1	0.24	2.4	14.1	60.6	26.8 x 22.0 x 7.1	SWi20/25TEEX
SWi2025TEMAXEX	External Hydraulic	27	4.1	0.24	2.4	14.1	85.5	36.6 x 23.6 x 7.1	SWi20/25TEEX
SWi2025TISTDEX	Integral Hydraulic	27	4.1	0.24	2.4	18.7	38.6	22.8 x 15.7 x 7.1	SWi20/25TIEX

* Using stepped blocks.

Flange Spreading Tools

SWi12/14TMEX -
ATEX Certified Mechanical
Flange Spreading Wedge



II 2G Ex h IIB T5 Gb
II 2D Ex h IIIC T185°F Db

SWi1214TMSTDEX - SWi12/14TMEX STD Kit



1 x SWi12/14TMEX Flange Spreading Tool
1 x ATEX Torque Wrench with 22 mm Socket
1 x Set of Safety Blocks
1 x Pair of Stepped Blocks
1 x Lanyard
1 x Hex Key
1 x Aluminium Carry Case with Protective Foam Inserts

SWi20/25TEEX -
ATEX Certified Hydraulic
Flange Spreading Wedge



II 2G Ex h IIB T5 Gb
II 2D Ex h IIIC T212°F Db

SWi2025TEMINEX - SWi20/25TEEX MIN Kit



1 x SWi20/25TEEX Flange Spreading Tool
1 x Set Safety Blocks
1 x Pair of Stepped Blocks
1 x Lanyard
1 x Hex Key
1 x Aluminium Carry Case with Protective Foam Inserts

SWi20/25TIEX -
ATEX Certified Integral Hydraulic
Flange Spreading Wedge



II 2G Ex h IIB T5 Gb
II 2D Ex h IIIC T212°F Db

SWi2025TISTDEX - SWi20/25TIEX STD Kit



1 x SWi20/25TIEX Flange Spreading Tool
1 x Set of Safety Blocks
1 x Pair of Stepped Blocks
1 x Lanyard
1 x Hex Key
1 x Carry-Strap
1 x Aluminium Carry Case with Protective Foam Inserts

SWi2025TESTDEX - SWi20/25TEEX STD Kit



1 x SWi20/25TEEX Flange Spreading Tool
1 x 10,000 psi ATEX Hydraulic Hose, 6.5 ft. with 90° Elbow
1 x 10,000 psi HP350S ATEX Single-Port Sealed Hand Pump with Gauge
1 x Set Safety Blocks
1 x Pair of Stepped Blocks
1 x Lanyard
1 x Hex Key
1 x Aluminium Carry Case with Protective Foam Inserts

SWi2025TEMAXEX - SWi20/25TEEX MAX Kit



2 x SWi20/25TEEX Flange Spreading Tools
2 x 10,000 psi ATEX Hydraulic Hose, 6.5 ft. with 90° Elbow
1 x 10,000 psi HP550D ATEX Twin-Port Sealed Hand Pump with Gauge
2 x Set Safety Blocks
2 x Pair of Stepped Blocks
2 x Lanyards
2 x Hex Keys
1 x Aluminium Carry Case with Protective Foam Inserts



These tools have been designed for use in potentially explosive atmospheres which is:

- Group II (Non-mining equipment)
- Equipment **category 2** where explosive atmosphere is likely to occur in normal operation
- Can be applied in **zones 1** and **2** of gaseous explosive atmospheres and in **zones 21** and **22** of dust explosive atmosphere
- **Gas G** or **Dust D** with type of protection **Ex h** for non-electrical equipment
- Suitable for use with **Group IIB** of a gases and vapours (Ethylene group) and **Group IIIC** of dust (conductive dust)

- For hydraulic tools **T5** means that minimum ignition temperature of gas or vapor **>212°F**; **T212°F** means that minimum ignition temperature of a dust cloud **≥302°F** and minimum ignition temperature of a 0.2 inch (5mm) dust layer **≥347°F**
- For mechanical tools **T6** means that minimum ignition temperature of gas or vapor **>185°F**; **T185°F** means that minimum ignition temperature of a dust cloud **≥261.5°F** and minimum ignition temperature of a 0.2 inch dust layer **≥ 320°F**

These tools have been designed and manufactured in accordance with the following transposed harmonized European standards:

- **EN ISO 80079-36:2016** Explosive atmospheres - Part 36: Non-electrical equipment for explosive atmospheres - Basic method and requirements;
- **EN ISO 80079-37:2016** Explosive atmospheres - Part 37: Non-electrical equipment for explosive atmospheres - Non-electrical type of protection constructional safety "c", control of ignition sources "b", liquid immersion "k"

▼ SG11TM



Range of Application

For a detailed range of application please request the Secure-Grip Mechanical or Hydraulic Operator Instruction Sheet.

- For use on all flange types with bolt-hole sizes ranging from 0.69 inches to 2.44 inches
- Unique expanding collet technology
- Little or no access gap required
- Secure bolt-hole locking mechanism



CAUTION

A minimum of two Flange Spreading Tools must be used when opening flange joints.

This will enable the operator to maintain an equal spreading distance across the flange faces.

OPERATING BENEFITS

- Time-saving, simple operation
- Measurable, controlled flange spreading force
- Virtually universal, the Secure-Grip Flange Spreader range covers ANSI, DIN, SPO, ASME, API and BS flanges

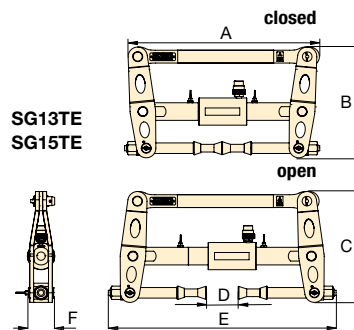
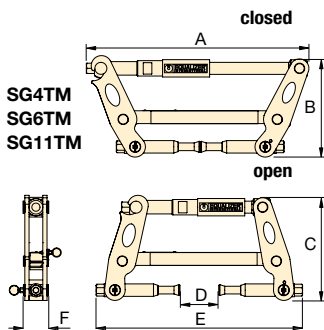

Flange Dimensions

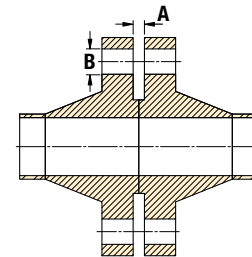

Model Number	Type *	Maximum Spreading Force Per Tool (ton)	Spreading Distance Maximum (in)	Flange Dimensions (in)		Tool Dimensions (in)						Tool Weight (lbs)	Kit Weight (lbs)	Case Dimensions (in)	Tool Number
				Minimum Access Gap A	Bolt-hole Diameter B	A	B	C	D	E	F				
SG4TMSTD	M	4.2	2.95	0	0.69 - 0.91	15.7	7.5	7.2	3.0	15.2	1.9	9.9	28.2	20.5x14.8x6.5	SG4TM
SG6TMSTD	M	6.7	3.15	0	0.94 - 1.18	18.4	9.6	9.9	3.1	17.5	2.0	16.5	35.3	25.2x21.3x6.5	SG6TM
SG11TMSTD	M	12.4	3.54	0	1.18 - 1.54	20.3	9.8	10.4	3.5	18.2	2.4	23.1	44.1	25.2x21.3x6.5	SG11TM
SG13TESTD	H	14.6	4.53	0	1.50 - 1.93	20.3	11.9	12.4	4.5	24.8	2.8	47.4	89.3	35.0x22.4x6.5	SG13TE
SG15TESTD	H	16.9	3.94	0	1.87 - 2.44	23.6	13.6	15.0	3.9	28.3	3.1	57.3	99.2	35.0x22.4x6.5	SG15TE

* M = Mechanical
H = Hydraulic

Flange Spreading Tools

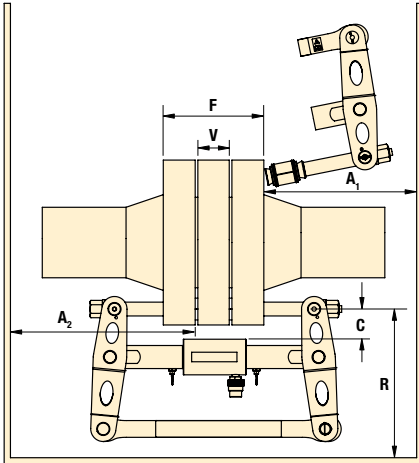

Spreading Force:
4.2 - 16.9 tons

Spreading Distance:
0 - 4.53 inches

Maximum Operating Pressure:
10,000 psi *

* Only relevant for hydraulic tools

SG Series



Model Number	Flange Joint Thickness F			Valve / Spacer Thickness V			Flange Clearance C		Radial Space R		Axial Space (for installation) A ₁		Axial Space (installed) A ₂		Tool Number	
	Min. (in)	Max. (in)	Measured: From / To	Min. (in)	Max. (in)	Measured: From / To	Max. (in)	Measured: From / To	Min. (in)	Measured: From / To	Min. (in)	Measured: From / To	Min. (in)	Measured: From / To		
SG4TMSTD	2.4	7.3	Outside face of flange / Outside face of flange	0*	1.8*	Inside face of flange / Inside face of flange	2.0	Bolt-hole circle / Largest OD of valve/ spacer	6.7	Bolt-hole circle / Closest obstruction	6.7	Outside face of flange / Closest obstruction	7.9	Inner face of flange / Closest obstruction	SG4TM	
SG6TMSTD	2.4	8.3		0*	2.0*		2.2				9.1		7.9		9.2	SG6TM
SG11TMSTD	3.8	9.4		0*	2.4*		2.4				9.4		8.8		10.2	SG11TM
SG13TESTD	4.7	12.2		0*	3.7*		2.8				11.0		12.2		10.2	SG13TE
SG15TESTD	5.5	15.7		0*	3.1*		3.1				14.6		15.0		12.4	SG15TE

* Short Collet Holder Kits (SCH) are available which can offer improved range of application.

SG4TM MECHANICAL TOOL KIT



- 1 X SG4TM Tool
- 1 X 6" Vernier Calliper
- 1 X 3/8" Drive Torque Wrench and 16 mm Socket
- 1 X Safety Block
- 2 X M16 (5/8") Collets
- 2 X M20 (3/4") Collets
- 1 x Aluminium Carry Case with Protective Foam Inserts

SG6TM MECHANICAL TOOL KIT



- 1 X SG6TM Tool
- 1 X 6" Vernier Calliper
- 1 X 3/8" Drive Torque Wrench and 21 mm Socket
- 1 X Safety Block
- 2 x M24 (7/8") Collets
- 2 x M27 (1") Collets
- 1 x Aluminium Carry Case with Protective Foam Inserts

SG11TM MECHANICAL TOOL KIT



- 1 x SG11TM Tool
- 1 x 6" Vernier calliper
- 1 x 1/2" Drive torque wrench and 24 mm socket
- 1 x Safety block
- 2 x M30 (1-1/8") Collets
- 2 x M33 (1-1/4") Collets
- 2 x M36 (1-3/8") Collets
- 1 x Aluminium Carry Case with Protective Foam Inserts

SG13TE HYDRAULIC TOOL KIT



- 1 x SG13TE Tool
- 1 x 10,000 psi HP550S Single Port Sealed Hand Pump with Gauge
- 1 x 10,000 psi Hydraulic Hose, 78.7"
- 1 x 6" Vernier Calliper
- 1 x 1/2" Square Drive Flexible Handle
- 1 x 1-1/8" Socket
- 1 x Safety Block
- 2 x M39 (1-1/2") Collets
- 2 x M42 (1-5/8") Collets
- 2 x M45 (1-3/4") Collets
- 1 x Aluminium Carry Case with Protective Foam Inserts

SG15TE HYDRAULIC TOOL KIT



- 1 x SG15TE Tool
- 1 x 10,000 psi HP550S Single Port Sealed Hand Pump with Gauge
- 1 x 10,000 psi Hydraulic Hose, 78.7"
- 1 x 12" Vernier Calliper
- 1 x 1/2" Square Drive Flexible Handle
- 1 x 1/2" Socket
- 1 x Safety Block
- 2 x M48 (1-7/8") Collets
- 2 x M52 (2") Collets
- 2 x M56 (2-1/4") Collets
- 1 x Aluminium Carry Case with Protective Foam Inserts

▼ SG18TE & SG25TE



- Applicable for larger-sized flanges
- Actuated by an external hand pump
- Suitable for bolt holes from 2.34 to 4.25 inches



Range of Application

For a detailed range of application please request the Secure-Grip In-Line Hydraulic Operator Instruction Sheet.



CAUTION

A minimum of two Flange Spreading Tools must be used when opening flange joints.

This will enable the operator to maintain an equal spreading distance across the flange faces.

SG18TE

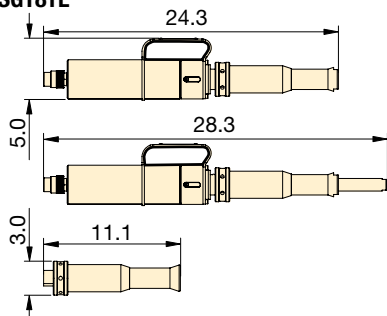

SG25TE

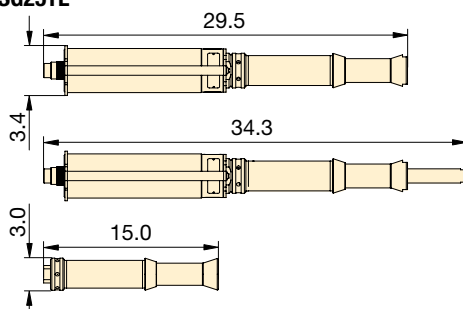

Flange Dimensions

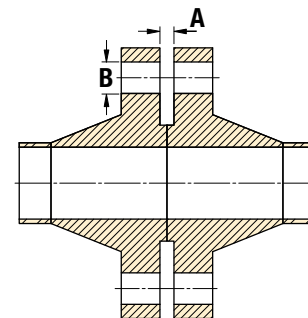

Model Number	Type	Maximum Spreading Force Per Tool (ton)	Spreading Distance Maximum (in)	Flange Dimensions (in)		Tool Weight (lbs)	Kit Weight (lbs)	Case Dimensions (in)	Tool Number
				Minimum Access Gap A	Bolt-hole Diameter B				
SG18TESTD	Hydraulic	20.2	3.93	0	2.34 - 2.95	30.9	99.2	35 x 22.4 x 6.5	SG18TE
SG25TESTD	Hydraulic	28.1	4.72	0	2.95 - 4.25	52.9	110.2	35 x 22.4 x 6.5	SG25TE

Flange Spreading Tools

SG Series



Spreading Force:

20.2 - 28.1 tons

Spreading Distance:

0 - 4.72 inches

Maximum Operating Pressure:

10,000 psi

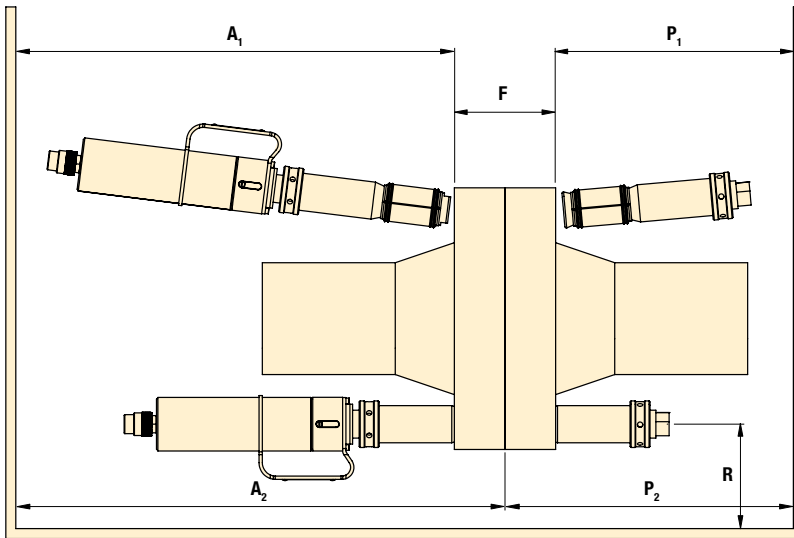

Model Number	Flange Joint Thickness F			Radial Space R		Axial Space (for installation) A ₁		Axial Space (installed) A ₂		Axial Plug Space (for installation) P ₁		Axial Plug Space (installed) P ₂		Tool No.
	Min. (in)	Max. (in)	Measured: From / To	Min. (in)	Measured: From / To	Min. (in)	Measured: From / To	Min. (in)	Measured: From / To	Min. (in)	Measured: From / To	Min. (in)	Measured: From / To	
SG18TESTD	7.5	17.7	Outside face of flange/ Outside face of flange	2.2	Bolt-hole circle / Closest obstruction	24.4	Outside face of flange/ Closest obstruction	35.4	Inner face of flange/ Closest obstruction	11.1	Outside face of flange/ Closest obstruction	11.1	Inner face of flange/ Closest obstruction	SG18TE
SG25TESTD	8.3	22.4	Outside face of flange/ Outside face of flange	2.2	Bolt-hole circle / Closest obstruction	29.5	Outside face of flange/ Closest obstruction	43.3	Inner face of flange/ Closest obstruction	15.0	Outside face of flange/ Closest obstruction	15.0	Inner face of flange/ Closest obstruction	SG25TE

SG18TE HYDRAULIC TOOL KIT



- 1 x SG18TE Tool
- 1 x Spreading Plug
- 1 x 10,000 psi HP550S Single Port Sealed Hand Pump with Gauge
- 1 x 10,000 psi Hydraulic Hose, 6.5'
- 1 x 12" Vernier Calliper
- 1 x 0.5" Spacer Plate
- 1 x 5mm Allen Key
- 1 x 2.0" Spacer
- 1 x Safety Block
- 2 x M60 (2-3/8") Collets
- 2 x M64 (2-1/2") Collets
- 2 x M70 (2-3/4") Collets
- 1 x Aluminium Carry Case with Protective Foam Inserts

SG25TE HYDRAULIC TOOL KIT



- 1 x SG25TE Tool
- 1 x Spreading Plug
- 1 x 10,000 psi HP550S Single Port Sealed Hand Pump with Gauge
- 1 x 10,000 psi Hydraulic Hose, 6.5'
- 1 x 12" Vernier Calliper
- 1 x 0.5" Spacer Plate
- 1 x Safety Block
- 1 x Aluminium Carry Case with Protective Foam Inserts

SG25TE COLLETS (AVAILABLE SEPARATELY)

Model Number	Description
673601-01	2 x M76 (3") Collets
673901-01	2 x M80 (3-1/4") Collets
674501-01	2 x M84 (3-3/8") Collets
674801-01	2 x M90 (3-1/2") Collets
675101-01	2 x M95 (3-3/4") Collets
675601-01	2 x M100 (4") Collets

▼ VC10TE



Valve Change-Out Tools



CAUTION

A minimum of two Flange Spreading Tools must be used when opening flange joints. This will enable the operator to maintain an equal spreading distance across the flange faces.



The Actuator and Extension

Subassembly can be assembled into 4 different configurations to suit a variety of applications. For a detailed range of application please request the VC10 Operator Instruction Sheet.

- Assists in the removal of wafer/butterfly valves, spades/spacers or gaskets from large flange joints
- Tool span is longer than a standard Secure-Grip Flange Spreader
- Adjustable to enable the tool to operate in a range of situations

PATENTED SECURE-GRIP SYSTEM:

- Unique expanding collet technology
- Secure bolt-hole locking mechanism
- Unique technology makes the Secure-Grip arguably the safest flange spreader for maintenance tasks involving the removal/inserting of Valves and Blinds
- Virtually universal, the Secure-Grip Flange Spreader range will cover ANSI, DIN, Norsok L005, ASME, API and BS Flanges
- Time-saving, simple operation

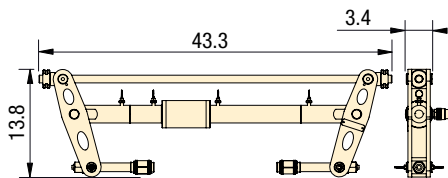

Flange Dimensions

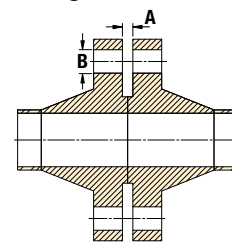

Model Number	Type*	Maximum Spreading Force Per Tool (ton)	Spreading Distance Maximum (in)	Flange Dimensions (pulg)		Tool Kit Weight (2 per Maxi Kit) (lbs)	Pump Kit Weight (lbs)	Gross Kit Weight (lbs)	Tool Case Dimensions (in)	Pump Case Dimensions (in)	Tool Number
				Minimum Access Gap A	Bolt-hole Diameter B						
VC10/13TESTD	H	11.2	22.8	0	1.50 - 1.93	110	60	170	21.7 x 47.2 x 6.7	21.7 x 47.2 x 6.7	VC10/13TE
VC10/13TEMAX	H	11.2	22.8	0	1.50 - 1.93	110	66	287	21.7 x 47.2 x 6.7	21.7 x 47.2 x 6.7	VC10/13TE
VC10/15TESTD	H	11.2	22.0	0	1.87 - 2.44	117	60	176	21.7 x 47.2 x 6.7	21.7 x 47.2 x 6.7	VC10/15TE
VC10/15TEMAX	H	11.2	22.0	0	1.87 - 2.44	117	66	300	21.7 x 47.2 x 6.7	21.7 x 47.2 x 6.7	VC10/15TE
VC10/18TESTD	H	11.2	20.2	0	2.34 - 2.95	128	60	187	21.7 x 47.2 x 6.7	21.7 x 47.2 x 6.7	VC10/18TE
VC10/18TEMAX	H	11.2	20.2	0	2.34 - 2.95	128	66	322	21.7 x 47.2 x 6.7	21.7 x 47.2 x 6.7	VC10/18TE
VC10/25TESTD	H	11.2	19.3	0	2.95 - 4.25	128	60	187	21.7 x 47.2 x 6.7	21.7 x 47.2 x 6.7	VC10/25TE
VC10/25TEMAX	H	11.2	19.3	0	2.95 - 4.25	128	66	322	21.7 x 47.2 x 6.7	21.7 x 47.2 x 6.7	VC10/25TE

* H = Hydraulic

Flange Spreading Tools

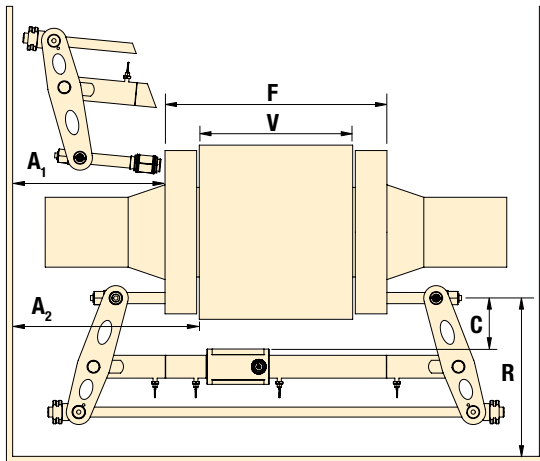

VC Series



Spreading Force:

11.2 tons

Spreading Distance:

0 - 22.8 inches

Maximum Operating Pressure:

10,000 psi

Model Number	Flange Joint Thickness F			Valve / Spacer Thickness V			Flange Clearance C	Radial Space R	Axial Space (for installation) A ₁	Axial Space (installed) A ₂	Tool Number
	Min. (in)	Max. (in)	Measured: From / To	Min. (in)	Max. (in)	Measured: From / To					
VC10/13TESTD	4.3	27.2	Outside face of flange / Outside face of flange	0*	22.8*	Inside face of flange / Inside face of flange	Bolt-hole circle / Largest OD of valve/spacer - max. 5.1"	Bolt-hole circle / Closest obstruction - min. 14.2"	Outside face of flange / Closest obstruction - min. 11.8"	Inner face of flange / Closest obstruction - min. 14.6"	VC10/13TE
VC10/13TEMAX	4.3	27.2		0*	22.8*						VC10/13TE
VC10/15TESTD	5.1	27.2		0*	22.0*						VC10/15TE
VC10/15TEMAX	5.1	27.2		0*	22.0*						VC10/15TE
VC10/18TESTD	6.9	27.2		0*	20.2*						VC10/18TE
VC10/18TEMAX	6.9	27.2		0*	20.2*						VC10/18TE
VC10/25TESTD	7.9	27.2		0*	19.3*						VC10/25TE
VC10/25TEMAX	7.9	27.2		0*	19.3*						VC10/25TE

* Short Collet Holder Kits (SCH) are available which can offer improved range of application.

TOOL KITS (1 PER STD KIT, 2 PER MAX KIT)



VC10/13TE	VC10/18TE
1 x VC10/13TE Tool	1 x VC10/18TE Tool
2 x M39 (1-1/2") Collets	2 x M60 (2-3/8") Collets
2 x M42 (1-5/8") Collets	2 x M64 (2-1/2") Collets
2 x M45 (1-3/4") Collets	2 x M70 (2-3/4") Collets
1 x Aluminium Carry Case with Protective Foam Inserts	1 x Aluminium Carry Case with Protective Foam Inserts
VC10/15TE	VC10/25TE
1 x VC10/15TE Tool	1 x VC10/25TE Tool
2 x M48 (1-7/8") Collets	1 x Aluminium Carry Case with Protective Foam Inserts
2 x M52 (2") Collets	
2 x M56 (2-1/4") Collets	
1 x Aluminium Carry Case with Protective Foam Inserts	

PUMP KITS



For STD Tool Kits
1 x 10,000 psi HP550S Single Port Hydraulic Hand Pump
1 x Hydraulic Gauge with Manifold
1 x 10,000 psi Hydraulic Hose, 6.5'
1 x Secure Grip Safety Block
1 x Square Drive Flexible Handle
1 x Vernier Calliper
1 x Aluminium Carry Case with Protective Foam Inserts
For MAX Tool Kits
1 x 10,000 psi HP1000D Twin Port Hydraulic Hand Pump
2 x Hydraulic Gauges with Manifolds
2 x 10,000 psi Hydraulic Hoses, 6.5'
2 x Secure Grip Safety Blocks
1 x Square Drive Flexible Handle
1 x Vernier Calliper
1 x Aluminium Carry Case with Protective Foam Inserts



Collet Sizing

It is important that the correct size of collet is used. An undersized collet could allow the collet holder to pull through its bore. An oversized collet has the potential to become jammed in the bolt-hole.



Range of Application

For a detailed range of application please request the Hydraulic Secure-Grip Valve Change-Out Tool Operator Instruction Sheet.

VC10/25TE COLLETS (AVAILABLE SEPARATELY)

Model Number	Description
673601-01	2 x M76 (3") Collets
673901-01	2 x M80 (3-1/4") Collets
674501-01	2 x M84 (3-3/8") Collets
674801-01	2 x M90 (3-1/2") Collets
675101-01	2 x M95 (3-3/4") Collets
675601-01	2 x M100 (4") Collets

▼ MG7TM



MG Series

FLANGE SPREADING TOOL

Spreading Force:

7.6 tons

Spreading Distance:

0.08 - 1.06 inches



Range of Application

For a detailed range of application please request the MG7TM Operator Instruction Sheet.



CAUTION

A minimum of two Flange Spreading Tools must be used when opening flange joints.

This will enable the operator to maintain an equal spreading distance across the flange faces.

- Reversible leg design giving greater range of applications
- Unique double-angled wedge produces a greater spreading force without reducing spreading distance
- Robust lightweight tool
- Spreading force of 7.6 ton

OPERATING BENEFITS

- Locks on to flange joint
- Safe, quick and easy operation
- Saves time and cost

MG7TMSTD Standard Kit



- 1 x MG7TM Tool
- 2 x Spreading Bar
- 1 x Moulded Plastic Carry Case

Tool retracted and advanced using large (Ø 0.8 in) spreading bar

Tool retracted and advanced using small (Ø 0.6 in) spreading bar

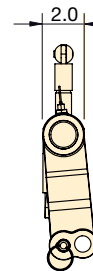
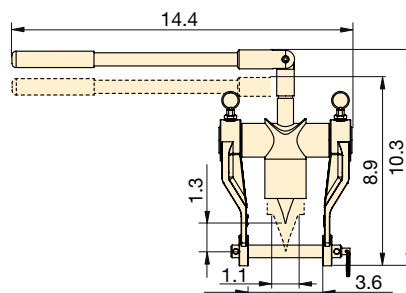
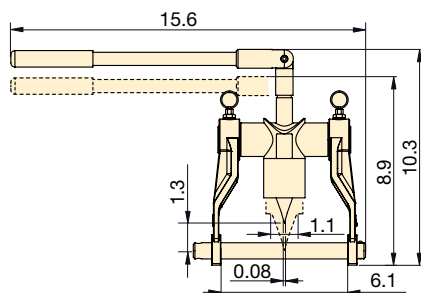

Flange Dimensions

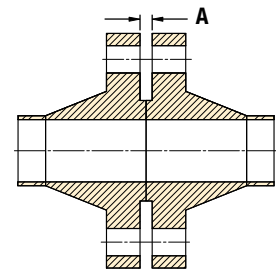

Model Number	Type	Maximum Spreading Force Per Tool (ton)	Spreading Distance Maximum (in)	Flange Dimensions	Wedge Width (in)	Tool Weight (lbs)	Kit Weight (lbs)	Case Dimensions (in)	Tool Number
				Minimum Access Gap A (in)					
MG7TMSTD	Mechanical	7.6	1.06	0.08	1.8	11.02	12.13	14.2 x 11.8 x 3.5	MG7TM

Flange Pulling Tools

▼ FC10TE



- Applicable to all flanges with a bolt-hole diameter of 1 inch or greater, including ANSI, DIN, Norsok L005, ASME and BS flanges
- Slide and lock collet system
- Low profile tool
- Can be used on all vertical and horizontal flanges including ANSI, API, BS, DIN & Norsok L005
- Robust yet lightweight
- Subsea compatible
- Reciprocating hydraulic action

OPERATING BENEFITS

- Reduction in operator fatigue
- Reduction in pinch point
- Quick and easy to use

Flange Dimensions

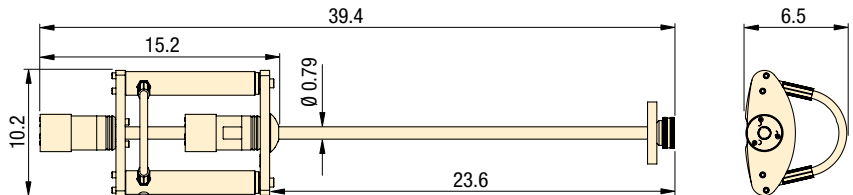
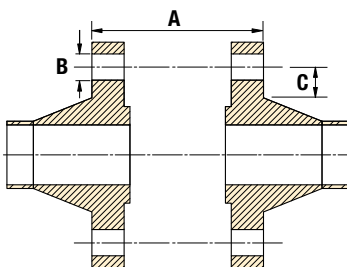

FC Series

FLANGE CLOSING TOOLS

Closing Force:

11.2 tons

Closing Distance:

22.4 - 0 inches

Maximum Operating Pressure:

10,000 psi



CAUTION

A minimum of two flange closing tools must be used when flange pulling. This will enable the operator to maintain an even gap between flange faces and prevent flange / gasket damage.

FC10TESTD STD Kit



- 1 x FC10TE Tool
- 1 x 10,000 psi Hydraulic Hose, 6.5' long
- 1 x 10,000 psi HP550S Single Port Sealed Hand Pump with Gauge
- 1 x Aluminium Carry Case with Protective Foam Inserts

FC10TEMAX MAX Kit



- 2 x FC10TE Tool
- 2 x 10,000 psi Hydraulic Hoses, 6.5' long
- 1 x 10,000 psi HP550D Twin Port Sealed Hand Pump with Gauge
- 1 x Aluminium Carry Case with Protective Foam Inserts

Model Number	Type	Maximum Closing Force Per Tool (ton)	Closing Distance (in)	Flange Dimensions (in)			Tool Weight (lbs)	Kit Weight (lbs)	Box/Case Dimensions (in)	Tool Number
				A	B min.	C min.				
FC10TESTD	Hydraulic	11.2	22.4	0.63-22.4	1*	1.3	24.3	51.8	35.0 x 22.4 x 6.5	FC10TE
FC10TEMAX	Hydraulic	11.2	22.4	0.63-22.4	1*	1.3	24.3	80.5	35.0 x 22.4 x 6.5	FC10TE

* For hole diameter greater than 1.7 inches, please contact Enerpac.

▼ TFA15TI



TFA Series

**WIND TURBINE TOWER
FLANGE ALIGNMENT TOOLS**

Hook Force:

4.5 - 30.3 tons

Aligning Distance:

1.7 - 2.6 inches

TFA4TM Mechanical Tool Kit



- 1 x TFA4TM Tool
- 1 x Torque Wrench
- 1 x Moulded Plastic Carry Case

TFA12TE / TFA15TE External Hydraulic Tool Kit



- 1 x TFA12TE or TFA15TE Tool
- 1 x Safety Lanyard
- 1 x Aluminium Carry Case with Protective Foam Inserts

TFA12TI / TFA15TI Internal Hydraulic Tool Kit



- 1 x TFA12TI or TFA15TI Tool
- 1 x Aluminium Carry Case with Protective Foam Inserts

The TFA Wind Turbine Tower Flange Alignment Tools have been developed to aid the alignment of large flanges on the inside of wind turbine towers during their assembly or installation.

- Assists in aligning / de-ovalizing large internal pipe flanges
- Helps resolve bolt-hole misalignment within tower sections of wind turbine towers
- Can be used both on and offshore

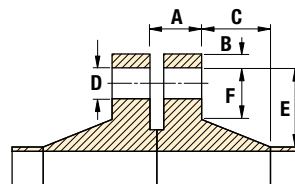

Flange Dimensions

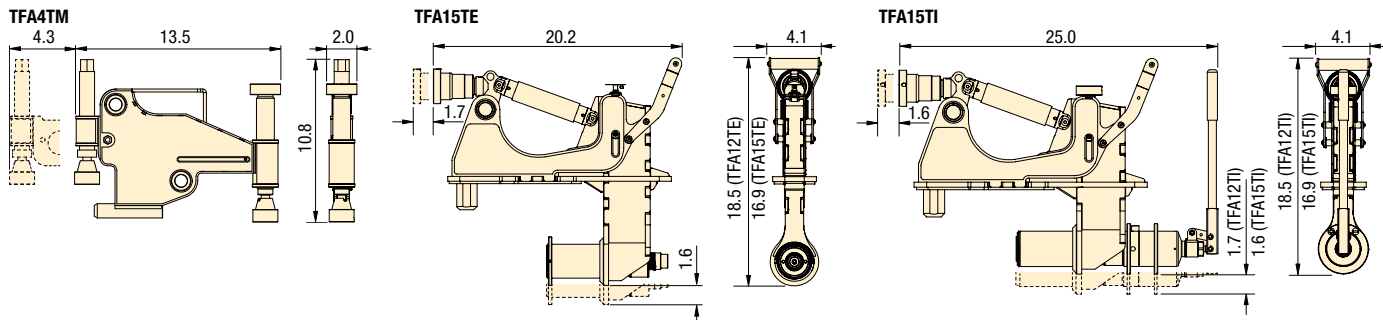

Model Number	Type*	Maximum Hook Force Per Tool (ton)	Maximum Aligning Distance (in)	Maximum Operating Pressure (psi)	Flange Dimensions (in)						Tool Weight (lbs)	Kit Weight (lbs)	Box/Case Dimensions (in)	Tool Number
					A	B	C	D min	E	F min				
TFA4TMSTD	M	4.5	1.7	-	1.4-5.3	0-2.2	0-9.1	0.98	0-4.1	0.94	17.9	39.7	23.6 x 14.6 x 7.9	TFA4TM
TFA12TEMIN	H	27.0	2.6	7,400	5.1-7.0	4.3-9.5	0-16.6	1.8	3.4-4.9	2.4	42.5	62.6	25.2 x 21.3 x 6.5	TFA12TE
TFA15TEMIN	H	30.3	2.6	10,000	3.5-5.4	4.3-9.5	0-16.6	1.8	3.4-4.9	2.4	41.7	61.7	25.2 x 21.3 x 6.5	TFA15TE
TFA12TISTD	H	27.0	2.6	-	5.1-7.0	4.4-9.5	0-16.6	1.8	3.4-4.9	2.4	48.3	68.3	23.0 x 35.4 x 6.3	TFA12TI
TFA15TISTD	H	30.3	2.6	-	3.5-5.4	4.4-9.5	0-16.6	1.8	3.4-4.9	2.4	47.4	67.5	23.0 x 35.4 x 6.3	TFA15TI

* M = Mechanical
H = Hydraulic

Hand Pumps & Hoses

▼ HP350DMIN



- HP-S, HP-D and HP-SD pump ranges are operable at all angles and are highly resistant to accidental spillage of hydraulic fluid (certified)
- The Single-Port and Twin-Port Hand Pumps are also available with ATEX rating, which are certified for use in hazardous areas II 2G Ex h IIB T5 Gb, II 2D Ex h IIIC T212° F Db

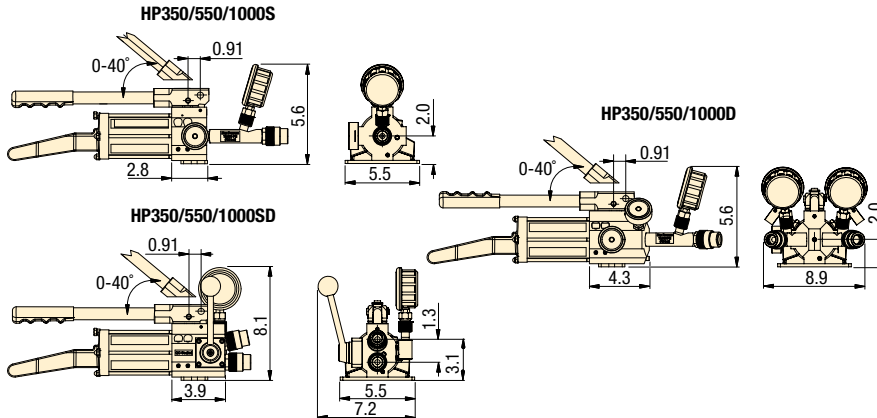

HP Series

**HYDRAULIC SEALED
HAND PUMPS**

Maximum Pressure Rating:

1st Stage: 197 psi

2nd Stage: 10,000 psi

Pump Type:

2-Speed



Pump Ratings

The Hydraulic Single Port, Twin Port and Double-Acting Hand-Pump (and hoses) are tailored for use with hydraulic equipment.

Each pump's output is regulated to 10,000 psi and is delivered from threaded 3/8" NPT output ports. The pumps and hoses can be used with any 10,000 psi rated hydraulic equipment within their oil capacity specification. The HP range of hydraulic hand-pumps have been designed with a seal oil reservoir, which allows the pumps to be used in any orientation without the risk of oil spills or air contamination.

10,000 PSI HOSES

AVAILABLE TO PURCHASE SEPARATELY

Model Number	Description
302701-01	Hydraulic Hose 78.7"
302702-01	Hydraulic Hose 157.5"
302705-01	Hydraulic Hose 118.1"
302706-01	Hydraulic Hose 196.9"
302707-01	Hydraulic Hose 236.2"
1440008-01	ATEX Hydraulic Hose 78.7"
1440013-01	ATEX Hydraulic Hose 157.5"
1440014-01	ATEX Hydraulic Hose 236.2"

Model Number Hand Pump Kit		Type*	Nominal Oil Capacity (in ³)	Useable Oil Capacity (in ³)	Oil Volume per Stroke (in ³)		Max. Handle Effort (lbf)	Piston Stroke (in)	Overall Length (in)	Box Dimensions (in)	Pump Weight (lbs)	Kit Weight (lbs)	Tool Number
Standard	ATEX				1st Stage	2nd Stage							
HP350SMIN	HP350SMINEX	SA, SP	21.4	18.3	0.221	0.047	72.75	0.71	21.8	9.8 x 7.1 x 23.6	9.7	10.8	HP350S
HP550SMIN	HP550SMINEX	SA, SP	33.6	35.4	0.221	0.047	55.12	0.71	25.3	9.8 x 7.1 x 27.6	11.2	13.0	HP550S
HP1000SMIN	HP1000SMINEX	SA, SP	61.0	67.7	0.221	0.047	46.30	0.71	34.1	9.8 x 7.1 x 35.4	13.4	15.7	HP1000S
HP350DMIN	HP350DMINEX	SA, TP	21.4	18.3	0.221	0.047	72.75	0.71	22.8	9.8 x 7.1 x 23.6	14.3	15.9	HP350D
HP550DMIN	HP550DMINEX	SA, TP	33.6	35.4	0.221	0.047	55.12	0.71	26.3	9.8 x 7.1 x 27.6	15.9	17.9	HP550D
HP1000DMIN	HP1000DMINEX	SA, TP	61.0	67.7	0.221	0.047	46.30	0.71	35.2	9.8 x 7.1 x 35.4	15.7	20.5	HP1000D
HP350SDMIN	N/A	DA	21.4	18.3	0.221	0.047	72.75	0.71	18.0	9.8 x 7.1 x 23.6	11.7	12.5	HP350SD
HP550SDMIN	N/A	DA	33.6	35.4	0.221	0.047	55.12	0.71	22.8	9.8 x 7.1 x 27.6	12.6	13.2	HP550SD
HP1000SDMIN	N/A	DA	61.0	67.7	0.221	0.047	46.30	0.71	30.3	9.8 x 7.1 x 35.4	13.0	13.9	HP1000SD

* SA = Single Acting
SP = Single Port

DA = Double Acting
TP = Twin Port

Enerpac's Heavy-Lifting Technology provides customers with tailored solutions, combining hydraulics, steel fabrication and electronic controls for safe, precise movement of heavy loads. Global Leader providing best in class solutions for safe and precise positioning of heavy loads.

With more than 60 years supporting industrial markets, Enerpac has gained the unique and in-depth expertise that is respected by industrial professionals around the world. Across every continent, Enerpac's network of application engineers, authorized distributors and technical service centers can reach any location, and deliver innovative solutions, technical assistance and quality products.

Enerpac's complete line of standard and customized products and a unique systems approach offers the benefits of safety and efficiency to applications where high forces are required.

Whether constructing a signature bridge across a deep valley, lifting a national landmark for seismic retrofit or simultaneously testing hundreds of foundation pilings to support a new building, Enerpac will supply the hydraulic solutions to get the job done safely and efficiently.



Precision lift and position of heavy loads



Synchronous superlift and launch



Bridge lifting and launching



Jacking with high capacity precision control



Synchronous hoisting and load positioning



Incremental bridge lifting











Transportation



Special high-tonnage cylinders for the Pioneering Spirit lifting beams

Heavy-Lifting Technology Section Overview

Capacity (tons)	Capabilities	Series		Page
140 - 280	Skidding Systems	LH HSK		360 ▶
17 - 1405	Heavy-Lifting Strand Jacks	HSL		362 ▶
110 - 1178	Telescopic Hydraulic Gantries	SL SBL		364 ▶
138 - 825	Jack-Up Systems	JS		366 ▶
60 - 250	SyncHoist	SHS SHAS		368 ▶
50 - 100	Trolley System	ETR		370 ▶
67	Self-Propelled Modular Transporter	SPMT		372 ▶
	Lifting Solutions			373 ▶

▼ Shown: HSK1250 Skidding System



Ideal Jack and Slide Solution



Skidding Systems

The skidding system is comprised of a series of skid beams moved by hydraulic push-pull cylinders, travelling over a pre-constructed track.

A series of special PTFE coated pads are placed on the skid tracks to reduce friction. The PTFE surface is matched with a sliding plate under the Enerpac skid beams, designed to achieve minimum friction coefficients.

The skid beams are connected by hoses to a hydraulic electric or diesel driven powerpack.

In addition to our standard skidding systems, Enerpac can create customized skidding systems to meet your specific requirements.

HSK-Series, Skidding Systems

- PTFE skid pads with dimpled surface for low friction and long lifetime
- Easy to replace skid pads, no tools necessary
- Bi-directional operation using push-pull cylinders avoid the need to reposition cylinders for switching direction
- Large load support surface on the skid beams for distributing load
- Bottom of skid shoes equipped with stainless steel sliding plates

LH-Series, Low-Height Skidding System

- Low starting height saves time and increases versatility
- Intuitive pump controls (SFP-Series Split-Flow Pump)
- Easily reversible to change skidding direction
- Portable design for quick setup

▼ LH400 series skidding system used to remove an obsolete press from a facility to make room for new equipment.



Controls

Enerpac offers several options for controlling our skidding systems.

Wireless Controls allows the operator the freedom to view the skidding operation from multiple locations while providing complete control of all system functions.

Manual controls offer a cost-effective solution by utilizing manual hydraulic valves mounted directly on the skidding system power unit.

▼ HSKJ1250 Skid Shoe Jack.





Skidding Systems

Enerpac Skidding Systems are available in several versions:

- **B-Series (Skid Beam)** utilizes a tall skid beam with built-in push-pull cylinders. Skidding direction can be easily switch by flipping a lever on the attached gripper box.

- **J-Series (Skid Jack)** provides the same functionality as the B-Series with the added benefit of having a built-in cylinder for lifting or leveling the load.
- **LH-Series (Low-Height)** includes low-height skid beams that can fit in tight spaces while still offering high capacity.

HSK LH Series



Capacity:

140 - 280 tons

Stroke Push/Pull:

23.62 inches

Lifting Stroke*:

6.89 inches

* HSKJ Skid shoe jack version only.

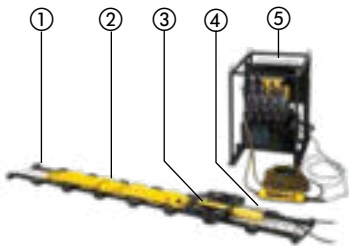

LH-Series Skidding System Requirements

- ① Skid Track (required)
- ② Skid Beam (required)
- ③ Push-Pull Cylinder Unit (required)
- ④ Hydraulic Hoses (required)
- ⑤ Split-Flow Electric Pump (required)
- ⑥ Track Support (optional, not shown)
- ⑦ Storage/Transport Frame (optional, not shown)
- ⑧ Pump Cart (optional, not shown)

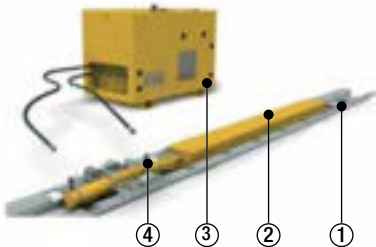

HSK-Series Skidding System Requirements

- ① Skid Track
- ② Skid Beam
- ③ Hydraulic Power Pack
- ④ Hydraulic Push-Pull Unit



Skid Tracks

Include specially constructed and easily replaceable PTFE coated pads. Skid track is sold separately.



Hydraulic Power Packs

Enerpac offers a comprehensive range of hydraulic power packs that are optimized for use with Skidding Systems.



Low-Height Skidding and Turntable

See pages 78-82 of this catalog for full details on these versatile products.

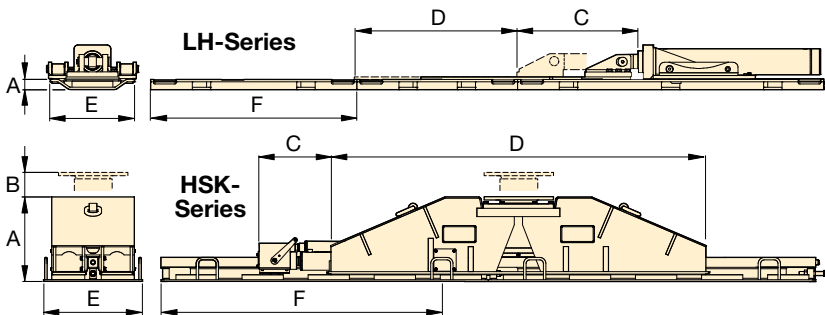

Maximum Capacity (per push-pull unit)*	Maximum Push-Pull Capacity (ton)		Model Number	Skid Beam Height (with track)	Lifting Stroke			Skid Beam Length	Skid Track Width	Skid Track Length	Skid Beam Weight	Skid Track Weight
	Push	Pull			A	B	C					
(ton)				A (in)	B (in)	C (in)	D (in)	E (in)	F (in)	(lbs)	(lbs)	
140	25	18	HSKB1250	12.17	–	23.62	98.43	15.75	78.06	1,631	265	
140	25	18	HSKJ1250	19.76	6.89	23.62	66.54	15.75	78.06	1,742	265	
280	45	30	HSKB2500	14.72	–	23.62	118.11	23.62	76.61	2,249	640	
280	45	30	HSKJ2500	23.62	6.89	23.62	70.23	23.62	76.61	3,197	640	
200	25	11	LH400 **	3.62	–	23.62	42.52	18.31	37.60	139	148	

* Note: Multiple push-pull units are combined to offer greater capacity. Typical setup is two or more units.

** Low-Height Skidding System. See pages 78-81 for details and components.

▼ Shown: HSL50006 Strand Jack



Heavy Lifting Strand Jacks

High Capacity - Precision Control



Strand Jacks

Enerpac strand jacks are the strand jacks of choice for customers seeking precise synchronous control with heavy lifting capacity in an economical, compact, and reliable foot print.

Enerpac strand jacks are powered by electrical or diesel driven hydraulic power packs and controlled by Enerpac's proprietary SCC-Smart Cylinder Control System to ensure full control of lifting and lowering operations.

Enerpac continually improves reliability, durability, and safety of their strand jacks, making them an industry standard for heavy lifting.

- Precision control of synchronous lifting and lowering
- Can be controlled by a single operator from a central location for increased safety
- Automated locking - unlocking operation
- Two strand sizes: 0.62" (15.7 mm) and 0.71" (18 mm)
- Telescopic strand guide pipes prevent bird caging
- Internal components are coated with an anti-corrosion coating, making it suitable for marine environments
- Lifting anchor included with all strand jacks
- Lloyds witness tested to 125% of maximum working load

▼ Shown: HSL85007 Strand Jack System used on Enerpac custom Self-Erecting Tower.



▼ Enerpac's SCC-Smart Cylinder Control System simplifies synchronous operation with intuitive controls and a user-friendly graphical interface.



Heavy Lifting Strand Jacks



Strand Jacks

A strand jack can be considered a linear winch.

In a strand jack, a bundle of steel strands are guided through a main “lifting” jack. Above and below the cylinder are anchor systems with wedges that grip the strand bundle simultaneously. Lifting and lowering a load is achieved by hydraulically controlling the main jack and both mini jacks alternately.

In the case of system pressure loss, the wedges are mechanically closed automatically, holding the suspended load in place.

Today, strand jacks are widely recognized as the most sophisticated heavy lifting solution. They are used all over the world to erect bridges, load out offshore structures, and lift/lower heavy loads where the use of conventional cranes is neither economical nor practical.

HSL Series



Capacity:

17 - 1405 tons

Stroke:

9.8 - 23.6 inches

Maximum Operating Pressure:

5,000 psi

Shown: HSL20006 Strand Jack

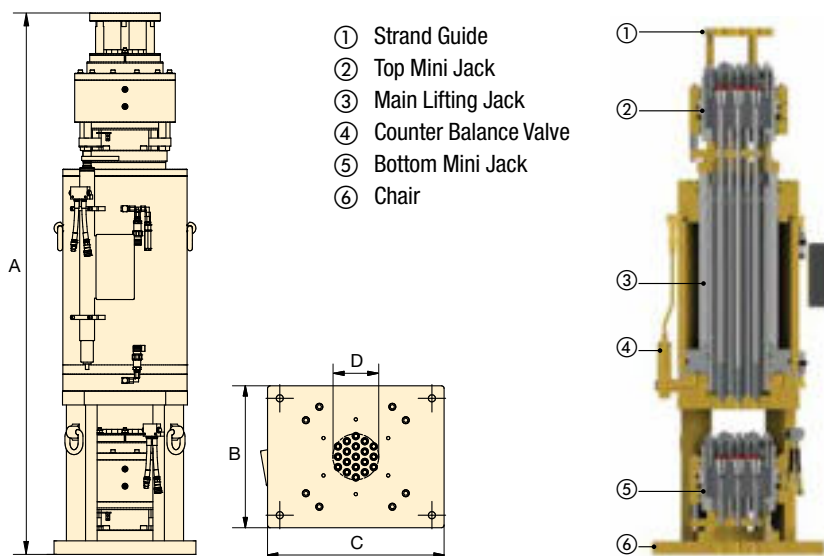

▼ **Strand Jack Accessories –**
Contact Enerpac for assistance at enerpac.com/contact-us



SLPP-Series Hydraulic Power Packs

Enerpac offers a comprehensive range of hydraulic power packs that are optimized for use with their industry leading strand jacks.



SG-Series Strand Guide

Provides a guide for the strand as a strand jack lifts the load.



SR-Series Strand Recoiler

Passively pays in or pays out strands while jacking and lowering.



SD1 Strand Dispenser

Essential to safely unbundle a new strand coil.



Lifting Anchor

Each Strand Jack includes a lifting anchor for attaching strand to the load.

Strand Diameter inch (mm)	Capacity (tons)	Model Number	No. of Strands	Stroke (in)	A (in)	B (in)	C (in)	D (in)	Wt. (lbs)
0.62 (15.7)	34	HSL3006	3	18.9	72.9	13.8	19.7	2.3	1,102
	79	HSL7006	7	18.9	75.4	14.2	22.6	3.7	1,411
	225	HSL20006	19	18.9	78.4	20.6	25.6	6.7	2,860
	337	HSL30006	31	18.9	80.6	26.5	26.5	8.5	4,820
	562	HSL50006	48	18.9	84.1	28.9	28.9	10.7	6,930
0.71 (18)	17	HSL1507	1	9.8	48.9	8.7	8.7	0.8	220
	51	HSL4507	3	18.9	68.0	13.8	19.7	2.9	1,102
	67	HSL6007	4	18.9	69.0	15.7	24.6	3.5	1,433
	112	HSL10007	7	18.9	75.8	16.1	24.6	4.6	1,874
	225	HSL20007	12	18.9	78.8	20.6	25.6	6.5	3,086
	337	HSL30007	19	18.9	80.9	26.5	26.5	8.3	4,290
	506	HSL45007	31	18.9	87.5	28.9	28.9	10.7	6,724
	731	HSL65007	43	18.9	88.1	33.5	33.5	13.8	8,690
	955	HSL85007	55	18.9	94.6	35.4	35.4	14.3	11,023
	1124	HSL100007	66	18.9	100.7	43.0	43.0	17.2	16,865
1405	HSL125007	84	23.6	104.6	43.3	43.3	18.0	18,298	

▼ Shown: SBL1100 with Skid Tracks, Header Beams and Side Shifts



- Self-contained hydraulics and electronics
- Intelli-Lift wireless control system
- Self-propelled wheels or tank rollers
- Foldable boom on SBL600, SBL900 and SBL1100 to enable easy transport and set-up
- Full range of supplementary equipment: header beams, lifting lugs, side shift, skid tracks
- Lloyds witness tested to 120% of maximum working load
- All gantries comply to ASME B30.1, CE, UKCA and other safety standards

Precision Lift and Position of Heavy Loads

The Ultimate in Safety and Control



Intelli-Lift

The Intelli-Lift wireless control system is included with all Enerpac hydraulic gantries.

The Intelli-Lift controller offers superior safety and control and includes the following features:

- Encrypted bi-directional communication that eliminates interference from other devices
- Remote operation using multi-channel wireless (2.4 GHz) or wired (RS-485) control
- High and low speed settings
- Automatic synchronization of lifting with an accuracy of 0.95 inch (24 mm)
- Automatic synchronization of travelling with an accuracy of 0.60 inch (15 mm)
- Overload and stroke alarms
- Remote side shift control
- Emergency stop switch

▼ Enerpac SBL-Series hydraulic gantries are used in a variety of applications to install turbines, transformers and other power generation equipment all over the world.



Maximum Capacity (4 legs)	Model Number	Retracted Height
(tons)		A (ft)
110	SL100	6.73
220	SL200	8.96
330	SL300	8.91
450	SL400N	8.94
450	SL400	10.39
585	SBL500	9.97
674	SBL600	14.11
1009	SBL900	16.42
1178	SBL1100	14.34

Telescopic Hydraulic Gantries



Hydraulic Gantries

Hydraulic Gantries are a safe, efficient way to lift and position heavy loads in applications where traditional cranes will not fit and permanent overhead structures for job cranes are not an option.

Hydraulic Gantries are placed on skid tracks to provide a means for moving and placing heavy loads, many times with only one pick.

Enerpac offers three series of Hydraulic Gantry systems:

- **SL-Series Super Lift**

The cost-effective SL-Series Super Lift offer control and stability for everyday lifting applications below 450 ton up to 30 feet.

- **SBL-Series Super Boom Lift**

The heavy-duty SBL-Series Super Boom Lift boom style gantries offer increased lifting capacity of over 450 ton to heights of almost 40 feet.

All Enerpac gantries are delivered with specific properties and control systems to ensure optimum stability and safety.

SL, SBL Series



Capacity:

110 - 1178 tons

Lift Height:

11.17 - 39.38 feet

▼ **Additional Accessories –**
Contact Enerpac for assistance at enerpac.com/contact-us

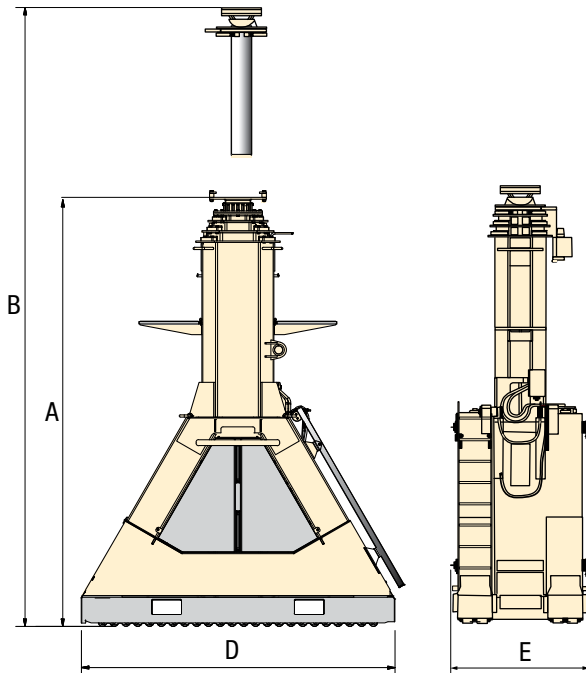

Drawing shows SBL-series, SL-Series without boom.



Skid Tracks

Skid tracks used for leveling and load distribution. Available in two standard lengths, 10 feet and 20 feet.



Header Beams

Sold in pairs and includes lifting points and fork pockets for easy positioning on gantry towers.

Available in 26.24 ft., 32.80 ft. and 39.36 ft. lengths.



Powered Side Shift

Electric propulsion controlled by standard gantry controls. Each set consists of 4 units.



Lifting Anchors

Designed to transfer the load to the top of the header beam. Can accommodate a 250 ton shackle or attach directly to the lifted load.

Stage 1		Stage 2		Stage 3		Base Length D (in)	Base Width E (in)	Weight per Leg (with oil) (lbs)	Model Number (4 legs)
Max. Height B (ft)	Max. Cap. (4 legs) (ton)	Max. Height B (ft)	Max. Cap. (4 legs) (ton)	Max. Height B (ft)	Max. Cap. (4 legs) (ton)				
11.17	110	15.59	66	–	–	55.12	34.65	3825	SL100
15.47	220	21.98	150	–	–	55.12	34.65	4850	SL200
15.11	337	22.01	220	–	–	66.93	34.65	7165	SL300
14.31	450	19.76	337	25.26	220	66.93	34.65	7937	SL400N
17.14	450	23.73	450	29.99	208	79.65	50.75	10,141	SL400
16.40	585	22.66	585	28.27	337	78.39	50.43	15,466	SBL500
21.33	674	28.22	562	34.78	416	128.74	64.65	19,842	SBL600
27.24	1009	37.09	664	–	–	135.98	55.43	29,432	SBL900
22.98	1178	31.72	760	39.38	424	135.98	55.43	26,345	SBL1100

▼ From left to right: JS125, JS250, JS500, JS750 Jack-Up System (one lifting tower shown)



Incremental Lifting System – Synchronously Lift and Mechanically Hold



Typical Applications

- Bridge maintenance
- Lifting and lowering of heavy equipment
- Lifting, lowering and levelling of heavy structures and buildings
- De-propping/load transfer from temporary steel work.



Computer Controls

Enerpac Jack-Up Systems provide precision control suitable for many demanding lifting and lowering applications. The comprehensive self-contained design features simple to use software.

- Automatic synchronization of multiple networked lift points
- Center of Gravity calculation
- Overload and stroke alarms
- Emergency stop switch at Jack-Up units and controls

- Self-contained hydraulics in each Jack-Up unit for uncluttered work area
- Synchronously lift loads with multiple Jack-Up units. The most common system set-up includes four Jack-Up units but can be expanded to include more
- Lifting barrels are stacked together to mechanically hold the load
- Up to 5% side load capacity depending on capacity and lift height
- Computer controls for operating the Jack-Up System with automatic and manual lifting settings

▼ Enerpac JS500 used in bridge construction and de-commissioning.



▼ Enerpac Jack-Up System hoists 1500-ton span on Fore River Bridge.



▼ Undocking an 1500-ton Electric Rope Shovel in a Copper Mine with a JS500 Jack-Up System for bearing inspection and maintenance.



JS-Series, Jack-Up Systems



Enerpac Jack-Up Systems

The Jack-Up System is a custom developed multi-point lifting system. A typical system setup includes four jack-up units, one positioned under each corner of a load.

Example: A four unit setup with JS250 has a lifting capacity of 1100 ton (275 ton per unit). The lifting frame of a jack up unit contains four hydraulic lifting cylinders, one in each corner, which lift the load using the stacked steel barrels.

A load is lifted in increments as barrels are slid into the system, lifted, and stacked; forming 'lifting towers'. A jack up system is operated and controlled by a computer control unit.

Each unit's lifting and lowering operations occur simultaneously; the computer control unit's synchronous technology maintains the balance of the load.

JS Series



Capacity per Lifting Tower:

138 - 825 tons

Lifting Height:

Up to 20 - 66 feet



Jack-up System Smart Box

The **Smart Box SBJS-V4** is Enerpac's proprietary control platform. It allows an operator to control up to 8 jack-up towers simultaneously with one **SBLT1** standard laptop.

- Single operator control from a central location provides safe and reliable operation
- Synchronous lift /lower and load control between the lifting positions
- Automatic lifting and lowering cycles
- Displays individual and accumulative stroke/load
- Simple graphical user interface

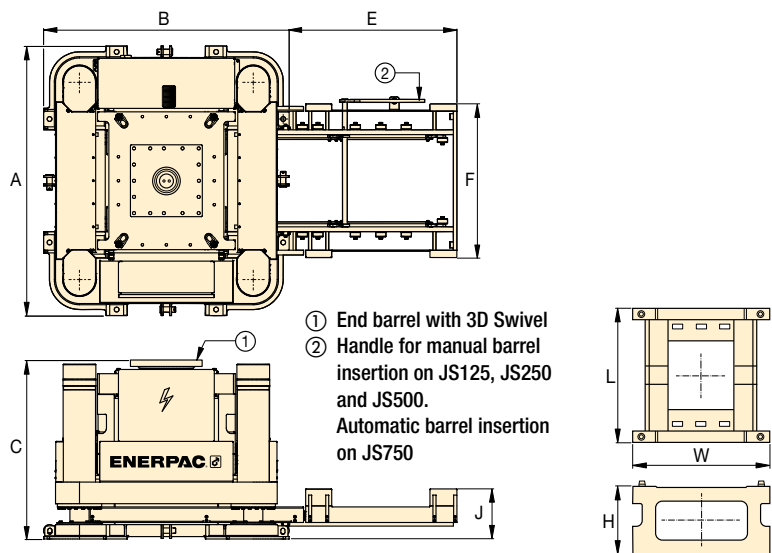

Jack-Up Systems (JS)

Steel Barrel (BLJS)

▼ Steel Barrel

For use with Jack-Up System	Barrel Set Model Number	Number of Barrels per Set	Barrel Dimensions (in)			Weight per Barrel (lbs)
			L	W	H	
JS125	BLJS125	4	23.62	23.62	11.81	231
JS250	BLJS250	4	45.28	45.28	19.69	792
JS500	BLJS500	4	66.93	66.93	27.56	2090
JS750	BLJS750	4	90.55	90.55	39.37	5170

▼ Jack-Up Systems

Capacity per Tower (ton)	Model Number	Maximum Sideload	Maximum Lifting Speed (ft/hr)	Base Frame Dimensions (in)			Barrel Loading System (in)			Electric Power Pack (hp)	Weight per Jack-Up Unit * (lbs)	Weight End Barrel (3D Swivel) (lbs)
				A	B	C	E	F	J			
138	JS125	3% @ 19.6 ft	16	47.25	43.31	37.60	27.56	27.56	8.07	12	5280	1254
275	JS250	3% @ 32.8 ft	13	88.58	80.71	58.07	52.81	52.81	16.46	20	16,500	5280
550	JS500	4% @ 49.2 ft	13	110.25	90.55	66.93	69.75	69.75	18.03	40	30,250	8470
825	JS750	5% @ 65.6 ft	13	144.50	127.95	93.50	98.25	98.25	29.29	40	52,800	19,800

* Weight per Jack-Up unit, excluding end barrel or barrel sets.



Adjustable Top Barrel

Includes double-acting lock nut cylinder with swivel saddle. Cylinder can be extended to contact the load. Provides

ability to adjust starting height of each leg, ensuring safe and stable lifting. Must be operated with separate pump.



Trolleys & Skid Tracks

Allows horizontal travel of jack-up systems.

▼ SHS-Series 4-Point SyncHoist System



- High-precision load maneuvering using one crane
- Reduces the risk of damage from oscillations of wire rope due to crane jogging and sudden starts/stops
- Vastly improving worker safety, operating speed and control
- PLC-controlled hydraulics turn lifting into high-accuracy hoisting and load positioning system
- Double-acting push/pull cylinders with load-holding valves for added safety
- Increased efficiency compared to conventional load positioning methods

Options for system management and control:

- **Manual control:** system warning functions
- **Automatic control:** fully PLC-monitored system with programmable functions using touch screen and system warning functions
- **Wireless control:** self-contained hydraulics with hand-held control

▼ Bridge segments are hoisted from the ground, being positioned with a 4-point SyncHoist system with fully monitored cylinders.



▼ Rigging engineers used the SyncHoist system to precisely monitor and adjust each lifting point independently, or together in a synchronized manner to position the 1140 ton nuclear plant module.



Accurate Hoisting and Load Positioning Enhancing a Crane's Capability



Synchronous Hoisting

Enerpac SyncHoist is a unique crane product for below-the-hook positioning of heavy loads that require precision placement. The SyncHoist system may reduce the number of cranes needed and reduce the costs of multiple picks.

Functions

- High precision horizontal and vertical load positioning
- Pre-programmed positioning, tilting and aligning.

Applications

- Positioning of rotor, stator and propeller blades of wind turbines
- Positioning of roof sections, concrete elements, steel structures
- Positioning of turbines, transformers, fuel rods
- Precise machinery loading, mill rod changes
- Precise positioning of pipe lines, blow out valves
- Positioning and aligning of ship segments prior to assembly.

▼ Offshore wind turbine base foundations installed with a wireless SHAS-SyncHoist System to ensure the foundation remained vertical during lowering and positioning.



SyncHoist - High Precision Load Positioning



What is SyncHoist?

Enerpac SyncHoist is a hydraulically operated auxiliary attachment for high precision load positioning for cranes. The SyncHoist system can be used for pre-programmed positioning, tilting and aligning of loads.

- Complete system tested in compliance with European lifting directive and safety requirements.

SyncHoist improves safety, operating speed and control of load movement

Geometric positioning of heavy loads in a horizontal and vertical plane are frequently done using more than one crane. Synchronizing movements between cranes are difficult and risky. The lifting inaccuracy can result in damage to the load and support structures and puts workers at risks. The SyncHoist system can be used for controlled hydraulic horizontal and vertical material handling.

System management and control

Contact Enerpac for the following options, or other customized stroke, capacity and control configurations.

1. Manual control

- Valves with manual levers
- Warnings for thermal motor protection
- Visual check: oil level, filter indicator.

2. Automatic control

- Load and stroke monitoring, and stroke control
- PLC-control and touch screen
- Solenoid valves with pendant
- Pre-programmable motions and data recording
- System warnings for:
 - maximum cylinder load control setting
 - stroke and position control
 - thermal motor protection
 - oil level and filter indicator.

Autonomous (wireless) system SHAS-Series

- Wireless remote control
- Only one electric power connection per lifting point
- Integrated hydraulics, PLC and controls
- No need for hydraulic hoses and cables
- No need for mid-hoist disconnection of hoses and movement of pump.

SHS, SHAS Series



Capacity:

60 - 250 tons

Maximum Stroke:

19.69 - 59.06 inches

Accuracy Over Full Stroke:

± 0.040 inches

Maximum Operating Pressure:

10,000 psi

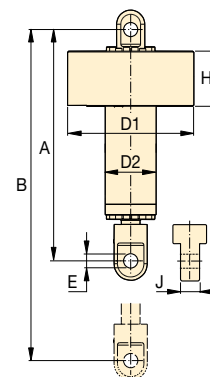

Capacity (ton)	Total Load (ton)	Cylinder Stroke (in)	Model Number ¹⁾ 460-480 VAC, 3 ph - 60 Hz	Control System	Motor Size (hp)	Number of Pump Outlets and Oil Flow ²⁾ (in ³ /min)	Cylinder Dimensions (in)							Wt. (lbs) ³⁾
							A	B	D1	D2	E	H	J	
4 x 60	240	19.69	SHS45520MJ	Manual	10	4 x 85	51.18	70.87	27.17	9.65	2.32	15.16	3.15	992
		39.37	SHS45540MJ				70.87	110.24						1378
		59.06	SHS45560MJ				90.55	149.61						1764
		19.69	SHS45520AJ	Automatic	20	4 x 128	51.18	70.78	27.17	9.65	2.32	15.16	3.15	992
		39.37	SHS45540AJ				70.87	110.25						1378
		59.06	SHS45560AJ				90.55	149.61						1764
4 x 94	376	19.69	SHS48520MJ	Manual	15	4 x 128	52.36	72.05	27.17	10.43	2.83	15.16	3.94	1102
		39.37	SHS48540MJ				72.05	111.42						1543
		59.06	SHS48560MJ				91.73	150.79						1984
		19.69	SHS48520AJ	Automatic	20	4 x 128	52.36	72.05	27.17	10.43	2.83	15.16	3.94	1102
		39.37	SHS48540AJ				72.05	111.42						1543
		59.06	SHS48560AJ				91.73	150.79						1984
4 x 120	480	39.37	SHS411040MJ	Manual	15	4 x 128	23.03	112.40	30.71	12.40	3.35	15.55	4.88	2138
		59.06	SHS411060MJ				92.72	151.77						2723
		39.37	SHS411040AJ	Automatic	20	4 x 128	73.03	112.40	30.71	12.40	3.35	15.55	4.88	2138
		59.06	SHS411060AJ				92.72	151.77						2723
4 x 120	480	39.37	SHAS411040WU ⁴⁾	Wireless	4 x 5	—	73.03	112.40	41.85	12.40	3.36	21.26	4.88	2608
		59.06	SHAS411060WU ⁴⁾				92.72	151.77						3192
4 x 250	1000	39.37	SHAS422540WU ⁴⁾	Wireless	4 x 10	—	84.25	123.62	48.62	16.54	5.59	22.83	7.48	7097
		59.06	SHAS422560WU ⁴⁾				103.94	143.31						7527

¹⁾ With 4 cylinders and one 460-480 VAC-3 phase-60 Hz power pack (suffix J). For 400 VAC-3 phase-50 Hz power pack change suffix J into W. Example: SHS45560MW.

²⁾ Pump and cylinders include 4x 82 feet hydraulic hoses with couplers. ³⁾ Weight per cylinder.

⁴⁾ WU = with US electrical wiring. Change into suffix "WE" for EU-market. Example: SHAS411060WE.

▼ ETR50H, Enerpac Trolley System (shown with Trolley Tracks)



Safe & Synchronized Travel



Product Overview

The ETR-Series Trolley System is comprised of electrically-driven trolleys which can carry heavy loads along a fixed track system. The entire system is controlled by a hand-held wireless control system. A typical system is comprised of 4 trolleys, 2 tracks and one controller. Trolley tracks and controller must be ordered separately.

- High transport speed
 - 164 ft/hour loaded
 - 328 ft/hour unloaded
- Suited for repetitive movements
- Runs on simple flat steel plate
- Ease of maintenance
 - long maintenance intervals
 - no consumables
- Clean usage – electric driven
- Built-in synchronization – no need for forced external mechanical connection to synchronize movements
- Easy transport - compact design
- Hydraulic lifting cylinder option available
- Kits to accommodate other lifting options also available



Control Panel and Cables

Operate up to 8 trolleys (same capacity each) using control panel with included wireless controller.

- Automatic synchronization of traveling with an accuracy of 0.39 inch (10 mm)
- Dual-band radio with automatic frequency search
- Wireless remote operation
- High and low speed settings
- Emergency stop switch
- Control cables operate trolley and provide feedback to controller

Control Panel

Model No. 460-480 VAC, 32A	Dimensions (in)			Wt. (lbs)
	L	W	H	
ETR-CPJ8	50.81	23.62	43.25	551

Control Cables

Model No.	Description
ETR-CBL-15	50-foot control cable
ETR-CBL-25	82-foot control cable

▼ The trolley system speeds up offshore wind transition piece load out: the transition pieces are positioned in the clamping frames and moved along the track.



▼ ETR series electric trolley undergoing factory acceptance testing prior to shipment.



Enerpac Electric Trolley System



ETR-Trolley System

The Trolley System provides an alternative method with increased benefits over traditional skidding methods.

Load movements are more stable due to the continuous movement and ability to precisely control travel speed including acceleration and deceleration.

Key features:

- Low speed: 82 feet/hour
- High speed: 164 feet/hour
- Accuracy: 0.38 inches
- Sideload: 1.5% rated load
- Sound Level: < 80 dBA

ETR Series



Capacity Per Trolley:

50 - 100 tons

Travel Speed (Loaded):

82 - 164 ft/hour

Motor Power:

0.5 - 1.0 hp

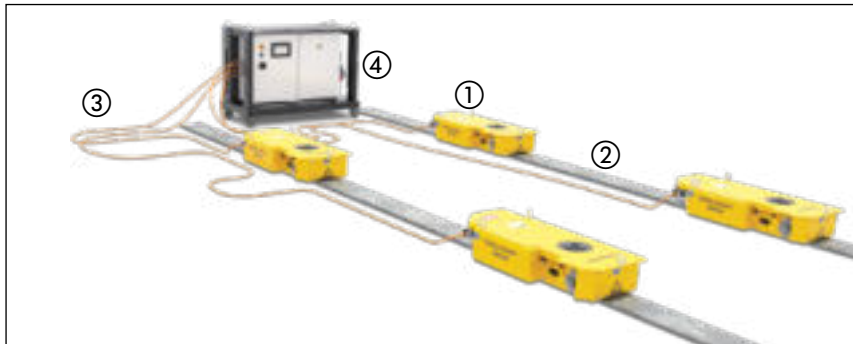

- ① Electric Trolley - ETR-Series
- ② Track Plate - ETR-TP-015 or ETR-TP-030
- ③ Control Cable - ETR-CBL-15 or ETR-CBL-25
- ④ Control Panel (inc. wireless remote) - ETR-CPJ8
- ⑤ Split-Flow Electric Pump - SFP-Series. Not shown. Optional for units with hydraulic cylinders.



Additional Mounting Options

Mounting kits are available to accommodate other lifting and rigging solutions.

Kit Model No.	Description
ETR50-SMK	Enerpac SCJ50 on ETR50
ETR100-SMK	Enerpac SCJ100 on ETR100
ETR50-BMK	Swivel beam mount on ETR50
ETR100-BMK	Swivel beam mount on ETR100

ETR50

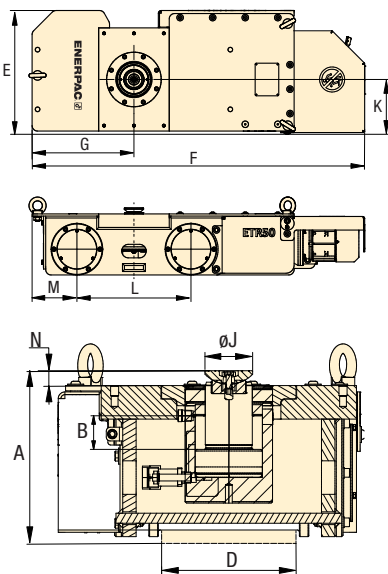

ETR100

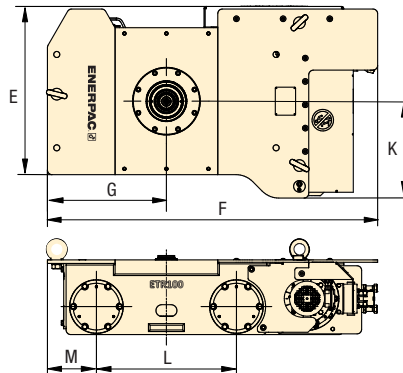

Trolley Track Plates

Track plates provide level guidance and support for the trolley. Two plates placed side-by-side are used for operation of ETR100-Series Trolleys. Maximum inclination of tracks is 0.2°.

Model No.	Trolley Track Plates (in)
ETR-TP-015	59" track plate
ETR-TP-030	118" track plate

Capacity per Trolley Unit (ton)	Model Number (one unit)	Motor Power (hp)	Hydraulic Stroke ¹⁾		Track Width ²⁾		G (in)	J (in)	K (in)	L (in)	M (in)	N (in)	Wt. (lbs)	
			A (in)	B (in)	D (in)	E (in)								F (in)
50	ETR50	0.5	9.65	N/A	7.87	17.95	48.23	14.76	4.92	7.95	16.54	6.50	0.39	684
	ETR50H		10.12	1.97									0.87	705
100	ETR100	1.0	13.62	N/A	15.75	32.32	55.71	20.08	6.69	16.34	23.62	8.27	0.59	1874
	ETR100H		13.74	3.94									0.75	1896

¹⁾ ETR50H includes HCG502 and CATS50. ETR100H includes HCG1004 and CATS101.

²⁾ ETR100 series uses two track plates side-by-side.

▼ Shown: SPMT600-360



SPMT Series

Capacity (per transporter):

67 tons

Transport Speed (unloaded-loaded):

1.9 - 1.0 mph

Motor Size:

75 hp



Self-Propelled Modular Transporter

The Enerpac Self-Propelled Modular Transporter (SPMT) features a minimized height and slim design, which makes it very easy to operate in confined spaces. Each wheel unit has a steering function as well as a lifting cylinder at its disposal. Wheel propulsion is established by wheel drives.

The SPMT is operated by the Intelli-Drive Remote Controller. This remote controller can be used both hard wired and wireless (based on radio frequency).

The SPMT is a modular system comprised of trailers with 3 axle lines each and diesel hydraulic power units (HPU). Depending on the model number, the trailers and HPUs can be configured to a maximum of 4 trailers in 2 rows (4x2) or 6 trailers in 2 rows (6x2).

This is the maximum setup of units that can work together on just one Intelli-Drive Remote Controller.



crab

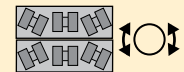

carousel

- **Modular design for multiple configurations**
- **Minimized height and slim design are ideal for in-plant operation**
- **Intelli-Drive wireless control system is intuitive and easy to use**
- **One power pack can operate 2-3 trailers maximum depending on model**
- **Two trailers and power pack can be shipped inside a 20 ft. container**
- **Hydraulic power unit is tier-4 diesel engine for reduced emissions**

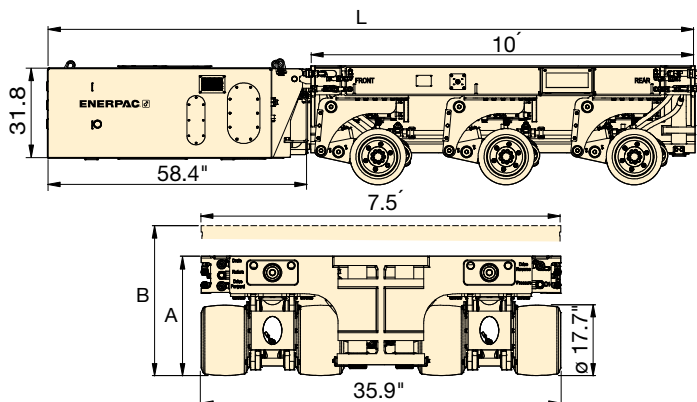

Capacity (per transporter) (ton)	Transporter Model Number	Maximum Configuration (transporters in rows)	Steering Range (degrees)	Steering Mode		Retracted Height	Average Travel Height		Overall Length	Lifting Stroke (in)	Wt. (SPMT) (lbs)	HPU * Model No.	Wt. (HPU*) (lbs)
				crab	carousel		A (in)	B (in)					
67	SPMT600-100	4 x 2	±50°	•	–	30.20	37.76	14.96	15.12	15,432	MTPP-100	5512	
	SPMT600-360	6 x 2	±179°	•	•	30.07	37.64	17.02	15.12	17,637	MTPP-360	5512	

* HPU = 75 hp Power Pack Diesel. HPU is sold separately.

FROM SIMPLE TO COMPLEX – LIFTING SOLUTIONS FOR YOUR APPLICATION

For those who do the heavy lifting today, the stakes are high and the challenges complex. We know our customers put their reputations and physical well-being on the line to get the job done right. We take that very seriously.

Backed by a global legacy of ultra-reliable quality and superior precision, Enerpac Heavy Lifting Technology is pushing the industry forward with a wide range of advanced solutions that first and foremost ensure our customers operate safely and productively every day. It isn't about being compliant, or "as good" as the next guy; we outpace the competition by delivering technically superior solutions that are easy to design, safe to use and built to outlast.

CONSULTATIVE APPROACH TO HEAVY LIFTING

From the very first discussion to gain an understanding of your application to solution design, training and ongoing field support of your operators, you will find a structured process and a team of application experts who will advise you towards a successful solution.



SOLUTION CONSULTATION

- Requirements Specifications
- Selecting the Right Solution for Your Application

DESIGN & MANUFACTURING

- Design & Engineering
- Manufacturing Excellence

TESTING & TRAINING

- Quality Assurance
- Operation & Safety Training

ON-DEMAND SUPPORT

- On-the-job Application Engineer Support
- Routine Maintenance & Repair Services

SOLUTION CONSULTATION

- Requirements Specifications
- Selecting the Right Solution for your Application

Since the late 1950's, Enerpac has been steadfast in their commitment to work closely with customers to understand their lift needs and work-site environment. Not all lifts are the same. There are several factors that must be taken into consideration before recommending the best solution.

APPLICATION CONSIDERATIONS

LOAD CAPACITY

How much weight needs to be lifted, moved and/or positioned?

LIFT HEIGHT

How high does the load need to be lifted? Are there restrictions above or below the load?

TYPE OF LIFT

Will you lift from above or below?

SPACE

How much space is available to complete the task?

TIME

How the job needs to be completed within a set timeframe due to operational or environmental factors.

TRANSPORTATION

Does the load need to be transported as well as being lifted? How far and how often?

TOTAL COST OF OWNERSHIP

What productivity, labor or training costs need to be factored into the solution to make it the best long-term investment.

Because Enerpac engineers have designed solutions for a variety of applications over the years, they are well-equipped to minimize risks and to recommend a simpler solution that others may overlook. Built on a world-class reputation for developing products that meet the most common lifting applications, once your specifications are in the hands of the Enerpac experts, you are sure to receive a comprehensive recommendation that will save time and money while ensuring safety above all else.



Enerpac has the most complete offering of standard heavy lifting and positioning tools in the market.

These products are designed to highest standards of performance and offer great flexibility to meet the demands of even the most challenging applications. Our manufacturing facility adheres to world-class production planning and inventory management to ensure your product arrives at your facility on time as specified.

DESIGN & MANUFACTURING

- Design & Engineering
- Manufacturing Excellence



Design & Engineering

Enerpac engineers are experienced in the latest software, rapid prototyping, failure analysis methods and engineering standards. This allows us to continuously improve and expand our product offering to meet ever changing needs of the market.

- CE, Machinery Directive 2006/42/E
- ASME: B30.1



Assembly & Quality Assurance

- All Enerpac products are assembled by highly trained individuals, working safely and efficiently from start to finish.
- The Hengelo, NL facility that manufactures the Enerpac heavy-lifting equipment holds several quality certifications.
- ISO 9001: 2015
- ISO 3834-2: 2005
- ISO 14001: 2015
- ISO 45001: 2018



Fabrication & Machining

- A dedicated steel fabrication and certified welding facility manufactures product components and support structures for the most demanding heavy-lifting applications.
- Complete in-house production is delivered using the latest CNC and conventional turning machines plus a full range of milling and boring equipment.



TESTING & TRAINING

- Quality Assurance
- Operation & Safety Training

The Enerpac facility, that makes and builds your heavy-lifting equipment, holds several quality system certifications giving you extra confidence in the safety and reliability of your heavy-lifting equipment. Whether your first lift or move is scheduled upon taking delivery of your new equipment or months later, you will have access to the dedicated Heavy-Lifting team to support your training or troubleshooting needs.



Factory Acceptance Testing (FAT)

Customers are invited to witness FAT, often combined with operator training. Under witness of Lloyd's Register, all equipment is functionally tested to maximum capacity, and in many cases up to 125% of rated load. Additional testing to meet standards compliance, government regulations or specific customer requirements are performed and documented at the same time.



Documentation

Upon delivery of your new heavy-lifting equipment, an operator's manual outlines the configuration of your system, detailed operating instructions with safety guidelines, and maintenance recommendations.



Training

Customers who attend factory acceptance training at Enerpac's facility can also receive a day of training on their heavy lifting equipment. Additional training or on-site custom training can also be arranged.



Once you take possession of your new heavy-lifting equipment, you have on-demand access to our field support team. And support continues with ongoing maintenance or system upgrades throughout the life of your assets.

ON-DEMAND SUPPORT

- On-the-Job Application Engineer Support
- Routine Maintenance & Repair Services



On-the-Job Field Support

Should you ever require extra support while using your Enerpac Heavy-Lifting system on the job, our dedicated application engineers will work closely to guide your operators on appropriate use of our equipment. And to ensure job safety, they will travel to your job site as needed to ensure your project is completed timely and without incident.



Product Warranty

All Enerpac Heavy-Lifting equipment is built to stringent specifications and built to last. Should you ever encounter a defect in materials or workmanship under normal use, it will be remedied through our standard one-year warranty program.



Maintenance & Repair

Downtime is minimized with fast delivery of repair parts and consumables stocked at several locations worldwide. For those that want the added confidence of specialized technicians, the Enerpac Maintenance & Repair team are ready to perform your maintenance or repair services for you.



Since joining the Enerpac portfolio, the design innovation of Mirage machines has continued to deliver new products that help get the job done faster, safer, and smarter. Explore the full product line from flange facing machines, milling machines, hot tapping, drilling and tapping machines to clamshell pipe cutters, decommissioning and band saws. All backed by Enerpac training, application support and service.



Specialist Support, Experience and Expertise

Design and Innovation

On-Site Machine Tools are the result of over 25 years of expertise and innovation. The pioneering spirit continues under Enerpac ownership through our commitment to new product development. Watch for more new tools being launched in the near future!



Utilities

Continuous Improvement

Our specialist manufacturing operation is ISO9001 certified. This means we drive a culture of continuous improvement. Our team members are encouraged to find ways to improve today, tomorrow, and long into the future.



Nuclear

Specialist Support, Experience and Expertise

Each machining project presents difficult and unique challenges. Making the right choice for your next and any future projects can be complex. That is why our team is eager to support you through every step on your journey. Whether it is choosing the right specification, commissioning your machine, or maintenance - we're with you all the way.



Oil & Gas



Petrochemicals



Power Generation



Ship Building, Maintenance and Repair













Wind Power



Construction and Mining

On-Site Machining Tools – Overview

Machining Capacities	On-Site Machining Tools	Series		Page
<p>ø 1 - 161 inches ø 25,4 - 4100 mm</p>	<p>Internal Mount Flange Facing Machines Create the right flange sealing surface</p>	<p>FF MM-I</p>		<p>380 ▶</p>
<p>ø 0 - 80 inches ø 0 -2032 mm</p>	<p>External Mount Flange Facing Machines Create the right flange sealing surface</p>	<p>MM-E</p>		<p>381 ▶</p>
<p>ø 2 - 86 inches ø 51 - 2184 mm</p>	<p>DL Ricci Clamshell Pipe Cutting and Beveling Machines Narrow Body, Mid-Size and Heavy-Duty</p>	<p>DLR</p>		<p>382 ▶</p>
<p>ø 98 - 315 inches ø 2500 - 8000 mm</p>	<p>General Orbital Milling Machines Machine large flanges accurately and efficiently</p>	<p>OM</p>		<p>384 ▶</p>
<p>ø 70 - 181 inches ø 1800 - 4600 mm</p>	<p>Wind Power Orbital Milling Machines Machine large flanges accurately and efficiently</p>	<p>WP</p>		<p>385 ▶</p>
<p>40 - 120 inches 1000 - 3000 mm</p>	<p>Linear Milling Machines On-site milling with workshop precision 2 and 3-axis configuration</p>	<p>LMR MR, MRY GM</p>		<p>386 ▶</p>
<p>ø 1/2 - 60 inches ø 12.7 - 1524 mm</p>	<p>Hot Tapping Machines and Line Stopping Actuators Built to deliver power where it matters most</p>	<p>HTM, LPH MHT, CHT LSA</p>		<p>388 ▶</p>
<p>ø 6 - 60 inches ø 152 - 1524 mm</p>	<p>Decommissioning Diamond Wire and Band Saws Cutting the toughest materials</p>	<p>MDWS BS</p>		<p>390 ▶</p>
<p>ø 2 - 12 inches ø 51 - 305 mm</p>	<p>Drilling and Tapping Machines Make light work of the toughest applications</p>	<p>HT T DDU</p>		<p>392 ▶</p>
<p>ø 7/8 - 11 inches ø 22 - 279 mm</p>	<p>GeniSYS™ IV Portable 3-axis CNC Mill Removal of cracked or broken studs and refurbishment of damaged threads</p>	<p>GeniSYS™</p>		<p>394 ▶</p>
<p>ø 3/4 - 40 inches ø 19 - 1016 mm</p>	<p>Inline Isolation and Test Tools Piping Isolation and Pressure Testing</p>	<p>MITT</p>		<p>396 ▶</p>

Internal Mount Flange Facing Machines



FF120

- Mechanical tool manually operated
- Simple to operate
- Lightweight - only 15 lbs (6,8kg)
- Multiple leadscrew options allow for manually driven, continuous fixed feeds for ASME standard surface finishes
- Calibrated slide to define cut depth and correct finish



MM3051 and MM6101

- Swivel tool post for groove details, reduces the need for separate accessories
- Supplied with a range of two quick-set base sizes for improved onto site operation
- Collet base allows for efficient machine mounting and centering



MM8601 and MM10001

- 360° swivel tool post for groove details, reduces the need for separate accessories (power feed on MM10001)
- Supplied with a range of three quick-set base sizes for improved onto site operation
- Adjustable height clamping jaws for efficient machine setting



MM15001

- Power feed 360° swivel tool post for groove details, reduces the need for separate accessories
- Supplied with a range of three quick-set base sizes for improved onto site operation
- Adjustable height clamping jaws for efficient machine setting



MM20001

- Power feed 360° swivel tool post for groove details, reduces the need for separate accessories
- Supplied with a range of two quick-set base sizes for improved onto site operation
- Adjustable height clamping jaws for efficient machine setting.



MM30001 and MM45001

- Power feed 360° swivel tool post for groove details, reduces the need for separate accessories
- Supplied with a range of three quick-set base sizes for improved onto site operation
- Adjustable height clamping jaws for efficient machine setting
- Milling accessories available with the hydraulic drive version.



Flange Facing Machines

Flange Facers are known for precision construction, the results they deliver, and how easy they are to set up on-site. These high-performing machines produce continuous groove facing feeds to ASME standards for the oil & gas, power generation and petrochemical industries.

MM-I Series feature

- Hardened slideways for long-term accuracy
- High torque, low noise drive
- Heat exchanger machining accessories available on most models.

Applications

- Heat exchanger flanges
- Hub profiles
- Lens ring joints and raised face flanges
- Recessed gaskets and spigots
- Ring type joint grooves (RTJ)
- SPO compact flanges
- Swivel ring and TECHLOK flanges
- Welding preparations.

▼ MM8601 machine to ensure flange joint integrity.



Internal Mount Flange Facing Machines

Flange Facing Diameter Range		Machine Model Number	Drive Power Options	
(inch)	(mm)		Pneum.	Hydr.
1 – 12	25 – 305	FF120 *		
2 – 12	51 – 305	MM3051	•	
2 – 24	51 – 610	MM6101	•	
6 – 34	152 – 864	MM8601	•	
6 – 40	152 – 1016	MM10001	•	
12 – 60	305 – 1524	MM15001	•	•
24 – 80	610 – 2032	MM20001	•	•
5 – 120	127 – 3048	MM30001	•	•
83 – 161	2100 – 4100	MM45001		•

* FF120 is not suitable for lens-ring flanges or ring type joints (RTJ) flanges.

External Mount Flange Facing Machines



MM200E

- Preloaded cross roller bearing drive, ensuring robust, accurate, repeatable machining
- Hardened slideways for long-term accuracy
- Swivel tool post for groove details, reduces the need for separate accessories
- Continuous fixed feed for ASME standard surface finish
- Quick-set integrated clamping jaws



MM300E

- Preloaded cross roller bearing drive, ensuring robust, accurate, repeatable machining
- Hardened slideways for long-term accuracy
- Swivel tool post for groove details, reduces the need for separate accessories
- Multiple continuous fixed feeds for ASME standard surface finishes
- Quick-set integrated clamping jaws



MM600E

- Preloaded cross roller bearing drive, ensuring robust, accurate, repeatable machining
- Hardened slideways for long-term accuracy
- Power feed 360° swivel tool post for groove details, reduces the need for separate accessories
- Multiple continuous fixed feeds for ASME standard surface finishes
- Quick-set integrated clamping jaws



MM760E, MM1000E, MM1250E, MM1500E, MM1775E, MM2000E

- Continuous variable auto-feed for ASME standard finishes
- Choice of pneumatic and hydraulic drive motors
- Quick-set radial clamping adjustment
- Quick-set axial adjustment jaws
- Heavy-duty bearing construction for high metal removal rates and accuracy
- Heat exchanger kits for back facing and slot machining in one operation.

External Mount Flange Facing Machines

Flange Facing Diameter Range		Machine Model Number	Drive Power Options	
(inch)	(mm)		Pneum.	Hydr.
0 - 8	0 - 203	MM200E	•	
0 - 12	0 - 305	MM300E	•	
0 - 24	0 - 610	MM600E	•	
0 - 30	0 - 762	MM760E	•	•
0 - 40	0 - 1016	MM1000E	•	•
0 - 50	0 - 1270	MM1250E	•	•
0 - 60	0 - 1524	MM1500E	•	•
0 - 70	0 - 1778	MM1775E	•	•
0 - 80	0 - 2032	MM2000E	•	•

FF MM Series



Internal Mount Facing Diameter:

1 - 161" / 25,4 - 4100 mm

External Mount Facing Diameter:

0 - 80" / 0 - 2032 mm

Cutting Resultant Roughness:

Ra 125-492 μin / 3,2-12,5 μ



Surface Finish and Accuracy

All Flange Facing Machines provide a serrated finish with 30-55 grooves per inch and a resultant roughness of between Ra 3,2-12,5μ (125-492 micro inches). Geared multiple continuous groove-facing feeds for a gramophone finish (ASME Standard).

▼ MM600E external mount flange facing machine to ensure flange joint integrity.



Narrow Body & Mid-Size Clamshell Cutters



DL Ricci Clamshell Cutters

Clamshell cutters in the Enerpac range remain true to the pioneering designs that made DL Ricci the 'go-to' brand for machinists worldwide. Outstanding performance and a comprehensive choice have seen them used widely for applications in new construction, decommissioning, component replacement, fabrication, and maintenance.

Robust and efficient pipe cutting and beveling

Designed for any industry that needs pipe or tube cutting, or any pipe end preparation weld repair. This may be in the oil & gas sector, power generation, ship building/dock yards, or processing plants during maintenance and shutdowns.

Applications

- Pipe cutting
- Weld preparation
- Cutting materials, including super duplex, carbon steel, stainless steel, Hastelloy® and Incoloy®
- For pipe diameters up to 86 inches (2184 mm)
- Ideal for projects beyond the usual clamshell configuration – using a wide range of purpose designed accessories.

Included as Standard with Each Machine:

- Clamshell body
- Locators and extensions covering the full range
- Slides
- Motor and mounting
- Air caddy
- Tool kit
- Manual
- Shipping crate

DLR-NB12, NARROW BODY CLAMSHELL CUTTER

- NB or "Narrow Body" portable clamshells are ideal when space is at a premium
- Standard NB-series cover a range from 2 to 36" outside diameter (51 to 914 mm)
- Narrow body design: ideal when space is at a premium or obstructions are present
- Pneumatic, hydraulic, and electric drive options
- Several different drive options are available to best position the motor for a specific machining application
- Accepts a wide range of accessories to increase performance and expand capabilities
- Full range of bevel and cutting tools available

DLR-MS30, MID-SIZE CLAMSHELL CUTTER

- Mid-size machines weigh less than the HD heavy-duty series, but provide greater rigidity than the NB-narrow body series
- Standard MS-series cover a range from 4 to 50" outside diameter (105 to 1270 mm)
- Increased maneuverability and greater clearance than the HD series
- Several different drive options are available to best position the motor for a specific machining application
- Accepts a wide range of accessories to increase performance and expand capabilities
- Full range of bevel and cutting tools available



◀ NB-model narrow body clamshell cutter.

NB Narrow Body Series Clamshell Cutters

Mounting Outside Diameter (min. - max.)		Machine Model Number	Drive Power Options		
(inch)	(mm)		Pneumatic	Hydraulic	Electric
2 – 4½	51 – 114	DLR-NB4	•	•	
2¾ – 6¾	60 – 168	DLR-NB6	•	•	
3½ – 8¾	89 – 219	DLR-NB8	•	•	•
4½ – 10¾	114 – 273	DLR-NB10	•	•	•
6¾ – 12¾	168 – 324	DLR-NB12	•	•	•
8¾ – 14	219 – 356	DLR-NB14	•	•	•
10¾ – 16	219 – 406	DLR-NB16	•	•	•
12¾ – 18	324 – 457	DLR-NB18	•	•	•
14 – 20	356 – 508	DLR-NB20	•	•	•
18 – 24	457 – 609	DLR-NB24	•	•	•
20 – 26	508 – 660	DLR-NB26	•	•	•
22 – 28	559 – 711	DLR-NB28	•	•	•
24 – 30	610 – 762	DLR-NB30	•	•	•
26 – 32	661 – 813	DLR-NB32	•	•	•
30 – 36	762 – 914	DLR-NB36	•	•	•

MS Mid-Size Series Clamshell Cutters

Mounting Outside Diameter (min. - max.)		Machine Model Number	Drive Power Options	
(inch)	(mm)		Pneumatic	Hydraulic
4½ – 13	105 – 330	DLR-MS12	•	•
7¾ – 16¼	187 – 413	DLR-MS16	•	•
9¾ – 18¼	238 – 464	DLR-MS18	•	•
11¾ – 20¼	289 – 514	DLR-MS20	•	•
15¾ – 24¼	391 – 616	DLR-MS24	•	•
19¾ – 28¼	492 – 718	DLR-MS28	•	•
21¾ – 30¼	543 – 769	DLR-MS30	•	•
23¾ – 32¼	594 – 819	DLR-MS32	•	•
27¾ – 36¼	695 – 921	DLR-MS36	•	•
27¾ – 36¾	708 – 934	DLR-MS365	•	•
33¾ – 42¼	848 – 1073	DLR-MS42	•	•
39¾ – 48¼	1000 – 1226	DLR-MS48	•	•

Clamshell Pipe Cutting & Beveling Machines

HD Heavy-Duty Clamshell Cutters



DLR-HD54, HEAVY-DUTY CLAMSHELL CUTTER

- Robust body design - ideal for large diameter heavy-wall pipe applications
- 16 heavy-duty models cover a range of 20 - 86" outside diameter (508 - 2184 mm)
- Pneumatic and hydraulic drive options
- Fully adjustable heavy-duty bearing design provides greater serviceability
- Stepped and keyed gear clamps equipped with a through bolt provide a positive fit at each assembly joint
- Accepts a wide range of accessories to increase performance and expand capabilities
- Full range of bevel and server tools available

HD Heavy-Duty Series Clamshell Cutters

Mounting Outside Diameter (min. - max.)		Machine Model Number	Drive Power Options	
(inch)	(mm)		Pneumatic	Hydraulic
20 - 32	508 - 813	DLR-HD32	•	•
24 - 36	610 - 914	DLR-HD36	•	•
27 - 39	686 - 990	DLR-HD39	•	•
31 - 43	787 - 1092	DLR-HD43	•	•
33 - 45	838 - 1143	DLR-HD45	•	•
36 - 48	915 - 1219	DLR-HD49	•	•
38 - 50	966 - 1270	DLR-HD50	•	•
41 - 53	1042 - 1346	DLR-HD53	•	•
42 - 54	1067 - 1360	DLR-HD54	•	•
43 - 55	1092 - 1397	DLR-HD55	•	•
45 - 57	1143 - 1448	DLR-HD57	•	•
48 - 60	1220 - 1524	DLR-HD60	•	•
54 - 66	1372 - 1676	DLR-HD66	•	•
60 - 72	1524 - 1828	DLR-HD72	•	•
68 - 80	1728 - 2032	DLR-HD80	•	•
74 - 86	1880 - 2184	DLR-HD86	•	•

DLR Series



Outside Mounting Diameter Range:

2 - 86 inches

Outside Mounting Diameter Range:

51 - 2184 mm



Recommended Accessories for Clamshell Cutters

Other clamshell accessories available. Details available on request.

Counter-bore Swivel Head Modules

- 10 inch size available
- Match boring applications
- Up to 60 degree adjustability in the head
- Internal diameter bevelling.

Description	Part Number
2 inch travel	F0108A1224AA-SK
6 inch travel	F0108A1224AB-SK

Low Profile Tool Slide

- Brings cut line closer to the back of machine
- Allows cutting & bevelling on short pipe sections
- Use for facing, RTJ grooves and compound angle weld preparations.

Description	Part Number
Low profile slide	F0130A0016XX

Out-of-round Tool Block Slide

- Dual compensating Spring Assembly
- Rides on OD of pipe and tracks the contour
- For up to 1 inch out-of-round.

Description	Part Number
Out of round slide	F0130A0022XX
Trippler for NB models	F0145A0019XX
Trippler for MS models	F0145A0020XX
Trippler for HD models	F0145A0028XX

▼ OM6000 Orbital Milling Machine



OM Series

Cutting Diameter Range:

98 - 315 inches

Cutting Diameter Range:

2500 - 8000 mm



General Orbital Milling Machines

Orbital milling machines are designed to deliver fast material removal and achieve high accuracy across large flange diameters.

Applications

- Machining crane bearing faces
- Repairing drag lines
- Machining large flanges
- Machining ship thruster flanges

Machine large flanges accurately and efficiently

- Precision flatness tolerances across large diameters
- Hydraulic high torque anti-backlash drive
- Precision preloaded linear rotary drive
- Adjustable fast-set hydraulic chuck
- Rigid and adjustable mounting base

▼ Machining crane bearing face.

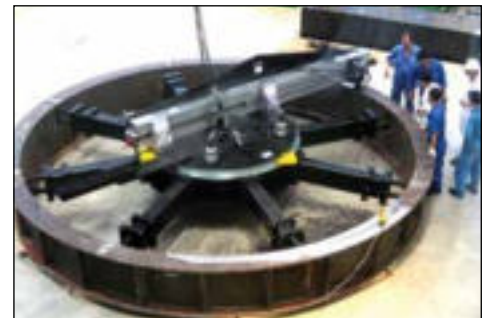

▼ Milling a ship thruster flange.



General Orbital Milling Machines

Cutting Diameter Range (min. - max.)		Machine Model Number	Hydraulic Power Drive
(inch)	(mm)		
98 - 178	2500 - 4500	OM4500	•
98 - 237	2500 - 6000	OM6000	•
138 - 315	3500 - 8000	OM8000	•

Wind Power Orbital Milling Machines

▼ WP3500 Wind Power Orbital Milling Machine

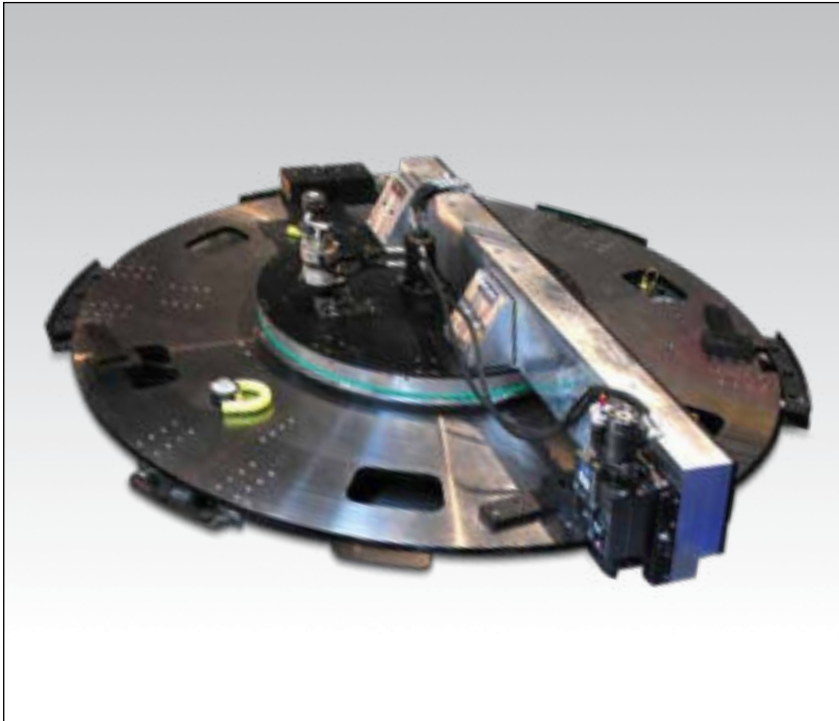

WP Series

Cutting Diameter Range:
70 - 181 inches

Cutting Diameter Range:
1800 - 4600 mm



Wind Power Orbital Milling Machines

The wind power orbital milling range is designed especially for companies manufacturing wind turbine rotor blades and towers.

Applications

- Wind turbine blade root end milling
- Wind tower flange machining.

Machine large flanges accurately and efficiently

- Fully packaged system; includes trolley, power unit and base
- Accurate and repeatable process time
- Minimum distortion, fast mount hydraulic base
- Adjustable arm for different diameters
- Patented hydraulic mounting system for blade and tower production
- Direct drive spindle
- High torque anti-backlash drive

▼ Wind tower machining with WP4600.



▼ WP3500 milling turbine blade end.



Wind Power Orbital Milling Machines

Cutting Diameter Range (min. - max.)		Machine Model Number	Hydraulic Power Drive
(inch)	(mm)		
70 - 96	1800 - 2450	WP2500	•
90 - 137	2300 - 3500	WP3500	•
110 - 181	2800 - 4600	WP4600	•

2-Axis Milling Machines

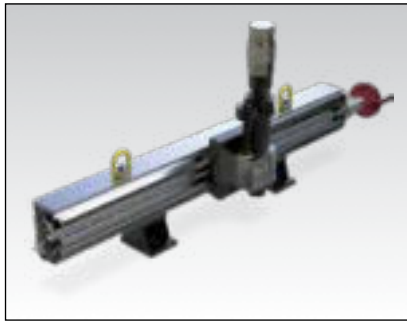

LMR1000, 2-AXIS MILLING MACHINE

- Ideal for lightweight applications
- Hand feed to main axis; auto feed optional
- Features ER40 Collet with ISO30 spindle option
- Choice of Pneumatic and Hydraulic drive

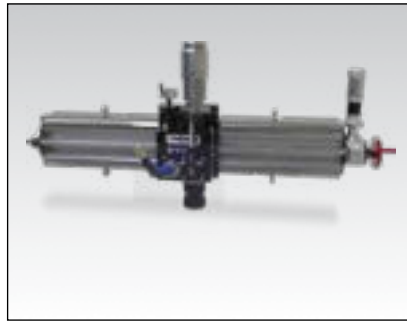

MR1000, 2-AXIS MILLING MACHINE

- Induction hardened 'V' rails ensure accuracy and durability
- Ball-screw feed
- Hand and auto feed to main axis
- Direct drive ISO 40 spindle
- Choice of Pneumatic and Hydraulic drive
- Variety of mounting options include bolting, switch magnets, pipe chain clamps and gantry

LMR, MR, MRY Series

X-Axis Maximum Stroke:

40 - 120" / 1,0 - 3,0 m

Y-Axis Maximum Stroke (MRY-Series only):

12 inches / 305 mm

3-Axis Milling Machines

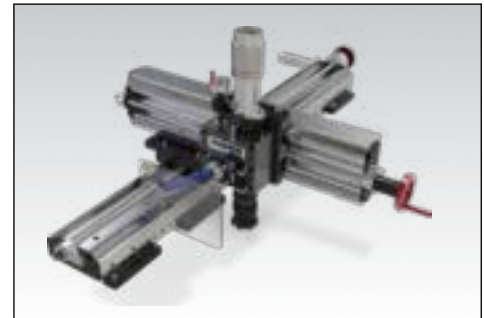

MRY1500, 3-AXIS MILLING MACHINE

- Induction hardened 'V' rails ensure accuracy and durability
- Ball-screw feed
- Hand and auto feed to main axis
- Direct drive ISO 40 spindle
- Choice of pneumatic and hydraulic drive
- Variety of mounting options including: bolting, switch magnets, chain clamps and gantry

▼ MRY Milling machine on a heat exchanger.



2-Axis Linear Milling Machines

X-Axis Maximum Stroke		Machine Model Number	Drive Power Options	
(inch)	(mm)		Pneumatic	Hydraulic
40	1000	LMR1000	•	•
60	1500	LMR1500	•	•
80	2000	LMR2000	•	•
40	1000	MR1000	•	•
60	1500	MR1500	•	•
80	2000	MR2000	•	•
120	3000	MR3000	•	•

3-Axis Linear Milling Machines

X-Axis Maximum Stroke		Y-Axis Maximum Stroke		Machine Model Number	Drive Power Options	
(inch)	(mm)	(inch)	(mm)		Pneumatic	Hydraulic
60	1500	12	305	MRY1500	•	•
80	2000	12	305	MRY2000	•	•
120	3000	12	305	MRY3000	•	•

Gantry Milling Machine



GMRF1000, GANTRY RAIL KIT

- Modular jointing system for lengths up to 32.8 ft (10 m)
- Linear rail and precision carriages
- Quick set up with jacking system
- Auto and manual feed
- Optional quick-set magnets for mounting

GMRF Series

X-Axis Maximum Stroke:

40 - 394" / 1,0 - 10,0 m

Y-Axis Maximum Stroke:

40 - 118" / 1,0 - 3,0 m



Linear Milling Machines – Take workshop precision to your next on-site milling project

These precise and robust milling machines are available in 2- and 3-axis configurations. Each includes the latest workshop tool technology in a portable format. For a fast and efficient set-up, you can choose our optional switch magnets.

Applications

- Motor and pump mounting pads
- Aerospace machining
- Crane pedestals
- Heat exchanger repair
- Shaft keyways
- Steel mill housings
- Turbine split-line machining



I-Beam end face milling with a GMRF1000.

Gantry Milling Machine

Feed Type	X-Axis Max. Stroke Options ¹⁾		Y-Axis Max. Stroke Options ²⁾		Machine Model Number	Drive Power Options	
	(inch)	(m)	(inch)	(m)		Pneumatic	Hydraulic
Rack Feed	40 - 394	1.0 - 10.0	40 - 118	1.0 - 3.0	GMRF1000	•	•

¹⁾ Common base module 39 inches.

²⁾ MR milling rail required. Extension kits available.

▼ HTM100



HTM, MANUAL HOT TAPPING

- Operates to 1480 psi (102 bar)
- Versatile hot taps, bypass lines and completion plugs
- Manual rotation and feed
- Optional pneumatic feed
- 2-inch NPT connection
- Lightweight construction.

▼ LPHT312

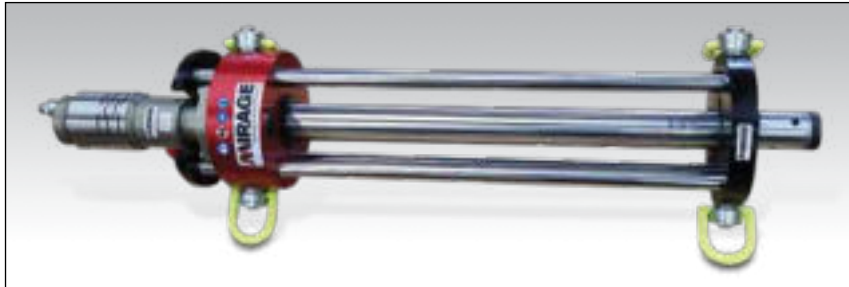

▼ MHT312



LPHT312, LOW PRESSURE HOT TAPPING

- Operates up to 285 psi (20 bar)
- Pneumatic or hydraulic drive
- Depth-stop to ensure correct hot tap distance

MHT, HOT TAPPING MACHINES

- Pressure rating up to 1480 psi (102 bar)
- Helical geared drive situated close to the cutter
- Hydraulic and pneumatic drive options
- Industry standard connection flanges
- Compatible with industry standard tooling
- Fast traverse feed motors available
- Cutter holders included
- Interchangeable seal cartridge

HTM, LPHT, MHT Series

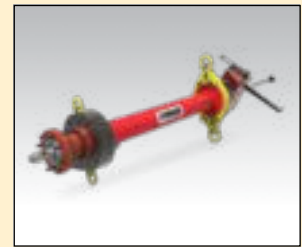

Tapping Diameters:

1/2 - 60 inches

Maximum Stroke:

18 - 150 inches

Maximum Operating Pressure:

285 - 1480 psi



Hot Tapping – Built to deliver power where it matters most

Hot tapping is a high-pressure intervention, and our range of hot tapping machines can help towards a safe and effective solution. Industry-leading innovations used include a helical gear drive located as close to the cutting head as possible for maximum efficiency, rotary pressure seals, and four fixed feeds.

Applications

- Construction tie-ins
- Gas distribution
- Petrochemical pipelines
- Subsea pipelines
- Temporary installation
- Transmission pipelines
- Valve installation and repair
- Water main pipelines
- Wellhead maintenance

▼ On-site hot tapping with MHT312.



Hot Tapping Machines

Tapping Diameters (Min. - Max.)		Maximum Stroke		Max. Operating Pressure		Machine Model Number	Drive Power Options	
(inch)	(mm)	(inch)	(mm)	(psi)	(bar)		Pneumatic	Hydraulic
1/2 - 4	12.7 - 102	18	457	1480	102	HTM100	*	*
1/2 - 6	12.7 - 152	32	813	1480	102	HTM150XL	*	*
3 - 12	76.2 - 305	30	762	285	20	LPHT312	•	•
3 - 12	76.2 - 305	42	1067	1480	102	MHT312	•	
4 - 20	102 - 508	72	1829	1480	102	MHT420		•
8 - 24	203 - 609	80	2032	1480	102	MHT824		•
12 - 36	76.2 - 914	110	2794	1480	102	MHT1236		•
12 - 42	76.2 - 1066	132	3353	1480	102	MHT1242		•
24 - 60	203 - 1524	150	3810	1480	102	MHT2460		•

* HTM has manual rotation and feed.

Hot Tapping Machines & Line Stopping Actuators

▼ CHT3000



CHT, LSA Series

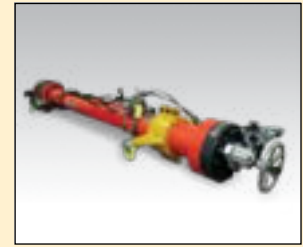

Tapping Diameters:

3 - 48 inches

Maximum Stroke:

43 - 150 inches

Maximum Operating Pressure:

1480 - 5000 psi

▼ LSA1420-H



LSA-Series Line Stopping Actuators

Line Stopping Actuators (LSA) are used in conjunction with the required line stop head and housings to carry out line stops in surface or subsea environments. The range is designed for easy use on pipelines in various materials and differing wall thickness. Their use provides temporary pipeline isolation, temporary or permanent bypass and no costly interruption of service.

CHT, HOT TAPPING MACHINES

- Working pressure capacity up to 5000 psi (350 bar)
- Drive as close to the cut enhances cut efficiency
- Auto feed — infinitely variable for differing cut conditions
- Constant pressure seal monitoring ports
- Internally pressure balanced for higher-pressure applications
- Industry standard connection flanges
- Compatible with standard industry tooling

LSA, LINE STOPPING ACTUATOR

- Series of four hydraulic line stop actuators covering a plugging head size range of 4 to 48 inches (102 - 1219 mm)
- Maximum working pressure of 1480 psi (102 bar) at 181 °F (83 °C)
- Failsafe mechanical lock prevents control rod movement
- Anti-rotation feature to ensure aligned plugging head deployment
- Hydraulic control situated at the working end of the cylinder for ease of use
- Visible control bar depth control.

CHT-Hot Tapping Machines and LSA-Line Stopping Actuators

Tapping Diameters (Min. - Max.)		Maximum Stroke		Max. Operating Pressure		Machine Model Number	Drive Power
(inch)	(mm)	(inch)	(mm)	(psi)	(bar)		
3 - 12	76 - 305	43	1092	5000	350	CHT1000	•
3 - 16	76 - 406	66	1676	5000	350	CHT1675	•
6 - 24	152 - 609	80	2032	5000	350	CHT2000	•
12 - 48	305 - 1219	150	3810	5000	350	CHT3000	•
4 - 12	102 - 305	72	1829	1480	102	LSA412-H	•
14 - 20	356 - 508	105	2667	1480	102	LSA1420-H	•
22 - 36	559 - 914	140	3556	1480	102	LSA2236-H	•
38 - 48	965 - 1219	140	3556	1480	102	LSA3848-H	•



▲ CHT3000 hot tapping application for petrochemical pipeline installation.

▼ CHT2000 hot tapping offshore application.



▼ MDWS1638-H



MDWS Series

Cutting Diameters:

6 - 60 inches



Decommissioning Saws

A range of portable saws for a diverse range of tubular severance projects.

The band saw range delivers a cost-effective solution to cold cutting requirements in either surface or subsea situations. Diamond wire saws are ideal for cutting through dissimilar materials quickly.

Applications

- Offshore platform decommissioning
- Conductors, caissons, piles
- Multiple grouted strings
- Subsea ROV-applications
- Subsea structures
- Pipes, casings and risers

Items included with each machine:

- Diamond wire rope
- Tool kit
- Storage / shipping crate
- CE Certificate
- Packing list and manual.

Cutting the toughest materials in the most challenging environments

- Strong aluminum frame
- Overload clutch for bow damage prevention
- Hydraulic auto clamp and auto-feed
- Diver and ROV compatible
- Available with optional flotation modules for deep water use
- User replaceable clamp contact pads, wheels, and wheel liners
- Crimped or continuous loop wires available



▲ MDWS Diamond Wire Saw lowered into sea.

▼ Subsea pile cutting.

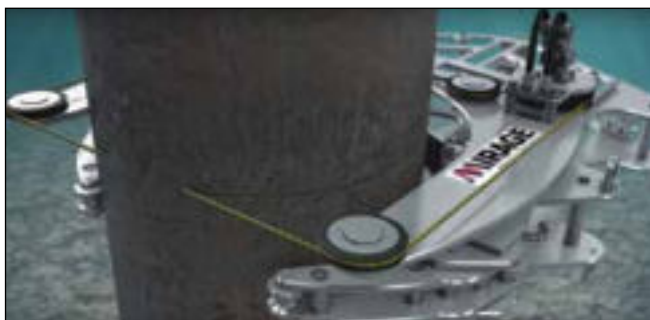

Decommissioning Diamond Wire Saws

Cutting Diameters (Min. - Max.)		Machine Model Number	Main Application	Hydraulic Drive Power
(inch)	(mm)			
6 - 20	152 - 508	MDWS620-H	Subsea	•
16 - 38	406 - 965	MDWS1638-H	Subsea	•
36 - 60	914 - 1524	MDWS3660-H	Subsea	•

▼ BS1636-H

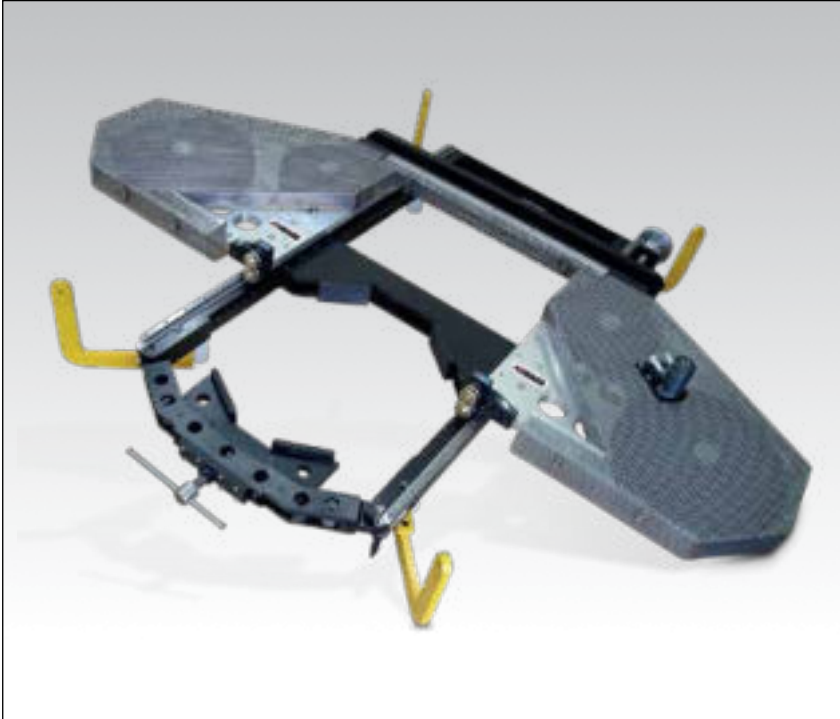

Cutting the toughest materials in the most challenging environments

- Fast, efficient and cost-effective cold cutting
- Cuts grouted multiple casings
- Fast mounting system
- Vertical or parallel operation
- Fast clamping and set up
- Low height design for minimum clearances
- Extensive blade selection for all materials

BS Series

Cutting Diameters:
9 - 36 inches



Portable Band Saws

Hydraulically powered portable band saws designed for tubular severance. Designed primarily for topside use, but also suitable for subsea applications.

Applications

- Offshore platform decommissioning
- Conductors, caissons, piles
- Multiple grouted strings
- Subsea ROV-applications
- Subsea structures
- Pipes, casings and risers

Items included with each machine:

- Band saw blade (2-3TP carbide tipped)
- Tool kit
- Storage / shipping crate
- CE Certificate
- Packing list and manual



▲ Pipe cutting with BS portable band saw.

▼ Decommissioning job with band saw.



Portable Band Saws

Cutting Diameters (Min. - Max.)		Machine Model Number	Main Application	Hydraulic Drive Power
(inch)	(mm)			
9 - 24	228 - 610	BS924-H	Topside	•
16 - 36	406 - 914	BS1636-H	Topside	•

Portable Drilling Machines



HT20

- 4MT spindle accepts standard tooling
- Linear rails and guides provide accuracy and high-load carrying capacity
- Direct spindle drive
- Manual and variable auto feed



HT50

- ISO50 geared spindle
- Linear rails and guides provide accuracy and high-load carrying capacity
- Geared reduction spindle drive
- Manual and variable auto feed



HT40

- ISO40 geared spindle
- Linear rails and guides provide accuracy and high load-carrying capacity
- Geared reduction spindle drive
- Manual and variable feed

▼ HT40 portable drilling machine.



HT Series

Drilling Capability:

Up to 5 inches

Maximum Stroke:

11 - 17 inches



Drilling and Tapping

Make light work of the toughest drilling and tapping applications

Drilling and tapping projects on-site require powerful and stable machines that deliver precise results first time. Our machines are designed to do exactly this - giving you reassurance that the job will be done efficiently and to the right specification. They offer high torque and easy operation through their heavy-duty spindles with ISO standard tapers.

Optional switch magnet mounts and chain clamps are also available for a quick and easy setup.

For large scale offshore decommissioning projects, casing pin drills provide an effective solution for creating lift holes into casings - especially in the most challenging of working environments.

Applications

- Drilling through armor plate
- Bulkhead hole cutting
- Flange stud drilling
- Flange stud re-threading
- Motor pump stud removal
- Short stroke line boring
- Turbine case stud removal
- Turbine pill drilling
- Casing pin drilling

Portable Drilling Machines

Maximum Diameter with Standard Drills		Maximum Standard Stroke		Machine Model Number	Drive Power Options	
(inch)	(mm)	(inch)	(mm)		Pneumatic	Hydraulic
2	50.8	11	279	HT20	•	•
4	101.6	16	406	HT40	•	•
5	127.0	17	432	HT50	•	•

Portable Tapping Machines



T30

- Rigid three pillar construction
- High-torque reduction drive
- Quick keyhole mounting
- Capable of tapping blind and through holes
- Hydraulic drive
- Pressure relief self-feed system



T725

- Heavy-duty four pillar construction
- Quick keyhole mounting system
- Capable of tapping blind and through holes
- High-torque reduction drive
- Hydraulic drive
- Pressure relief self-feed system

T, DDU Series

Tapping Capability:

Up to 7¼ inches

Case Pin Drilling Diameter:

Up to 12 inches

Maximum Stroke:

12 - 16 inches



GeniSYS IV Portable CNC Mill

Ideal for removal of cracked or broken studs and refurbishment of damaged threads. For hole diameters up to 11 inches and maximum 15.1 inch depths.

Page: 394

Casing Pin Drilling Machine



DDU1636

- Efficient pin drilling cold cut method
- Horseshoe mount options
- Helical drive spindle
- 4-inch cutter assembly supplied as standard
- Alternative cutter kits available up to 12 inches



Included as Standard with each Machine

- Tool kit
- All required mounting legs and connections
- Storage/shipping box
- CE certificate
- Operator's manual
- Packing list

Portable Tapping and Casing Pin Drilling Machines

Maximum Diameter with Standard Drills		Maximum Standard Stroke		Casing Pin Drill Clamping Diameter		Machine Model Number	Drive Power Options	
(inch)	(mm)	(inch)	(mm)	(inch)	(mm)		Pneumatic	Hydraulic
3	76	12	305	–	–	T30	•	•
7¼	184	13	330	–	–	T725	•	•
12	305	16	406	9 – 24	228 – 609	DDU924		•
12	305	16	406	16 – 36	406 – 914	DDU1636		•

▼ DDU1636 casing pin drilling.



▼ GeniSYS™ IV Portable CNC Mill

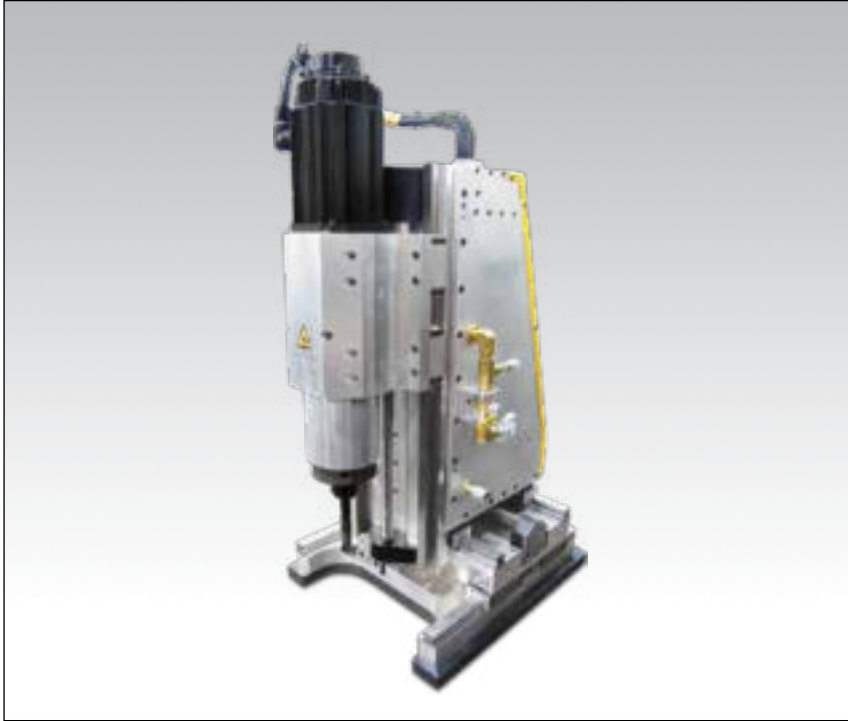

For removal of cracked or broken studs, and refurbishment of damaged threads



Included as Standard

The machine is supplied complete with the following items:

- GeniSYS IV milling machine
- Control System
- Laptop
- Motor and cables
- Storage / shipping boxes
- Operator's manual

- **CNC software allows the GeniSYS IV to be programmed to perform multiple tasks within its working envelope**
- **Can create bore and thread hole diameters ranging from 0.875 – 11 inches (22,2 mm – 279,4 mm)**
- **Hole depths up to 15.12 inches (384 mm)**
- **High tolerance profile rails produce consistent results**
- **All three axes utilize precision ground ball screws, providing precise movement of the milling head**
- **Accurate and repeatable machining**
- **A cold cutting operation**
- **Ejects chips during operation**
- **Single machine capable of drilling, threading and general milling applications**

▼ GeniSYS IV CNC Milling Machine.



▼ Thread cutting



GeniSYS™ IV Portable 3-Axis CNC Milling Machine



GeniSYS™ IV Portable CNC Mill

The GeniSYS IV is a highly portable 3-axis CNC milling machine.

The motion control command center provides the ultimate in performance monitoring and technician safety.

Designed for the accurate removal of cracked or broken studs up to 11-inch diameter and the precise refurbishment of damaged threads. This is achieved without the need for manually controlled drilling or metal disintegration techniques.

Can be used for automated general profile milling applications.

Typical examples

- Manway covers
- Reactor studs
- Bolt extraction and threading applications
- Recirculation pumps
- Turbine cases
- Heat exchangers
- Motor bases and many more high impact assets

GeniSYS

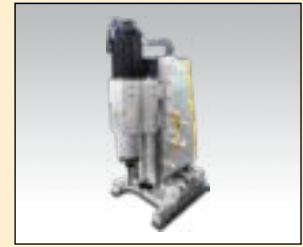

Hole Diameter:

7/8 - 11 inches

Hole Depths:

Up to 15.12 inches



▲ A typical thread before refurbishment



▲ New machined thread



▲ Enlarging a hole



▲ Coring out the center of a bolt (minor diameter).



Tooling

Standard tooling packages available to support general milling and thread milling applications.

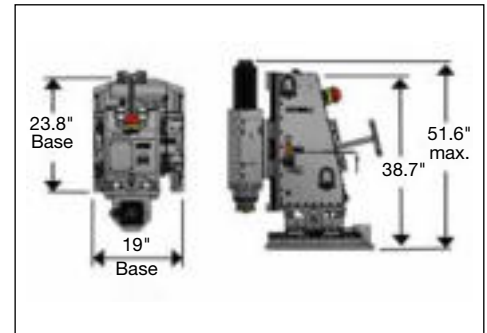

Dimensions GeniSYS IV

Base Length		Base Width		Total Height		Weight	
(inch)	(mm)	(inch)	(mm)	(inch)	(mm)	(lbs)	(kg)
23.8	605	19	483	51.6	1311	1100	499

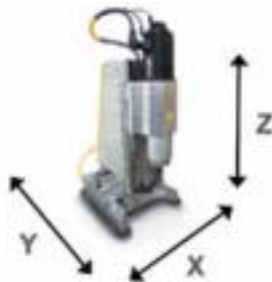

Specifications GeniSYS IV Portable 3-axis CNC Milling Machine

Hole Diameters (Min. - Max.)		Machine Model Number	Maximum Hole Depth		Milling Head Maximum Travel						Spindle Speed (RPM)	Spindle Motor		Motor Voltage (Volt, 3 phase)
(inch)	(mm)		(inch)	(mm)	X-axis		Y-axis		Z-axis			(hp)	(kW)	
7/8 - 11	22.2 - 279.4	GeniSYS IV	15.12	384	8	203.2	8	203.2	17	431.8	3000	6.7	5.0	380 - 440

▼ Shown: MITT6A, MITT16A, MITT2A, MITT1A



Ultimate Versatility in Piping Isolation and Pressure Testing



Inline Isolation and Test Tools

MITT-series tools obsolete traditional pipe cleaning and hydrotesting methods used for maintenance and construction operations.

The MITT series tools improve safety by limiting the test pressure volume and reduce downtime by eliminating cleaning requirements.

Key benefits of the tools include:

- Significantly reduce maintenance project timelines
- Safely perform welding on hydrocarbon lines with the peace of mind of a positive pressurized hydrostatic isolation
- Achieve significant reduction in wastewater (<1/4 gallon of water required for a 24-inch test)
- Patent Pending.

- **Combination Isolation and Test Tool assures vapor-free isolation for hot work and high-pressure capability between seals for testing welds with one tool**
- **Multi-schedule capability – up to 6 schedules covered per tool, 40 tools cover 154 pipe diameter / schedule combinations**
- **Lightweight, slim and versatile design – no crane required, able to mount in elbows and tees, able to test mismatched schedules**
- **High-pressure capability – test welds with relative ease up to 4500 psi**
- **Self-centering tools are user-friendly and require minimal training**
- **Hydrodynamic capability for heat treating**

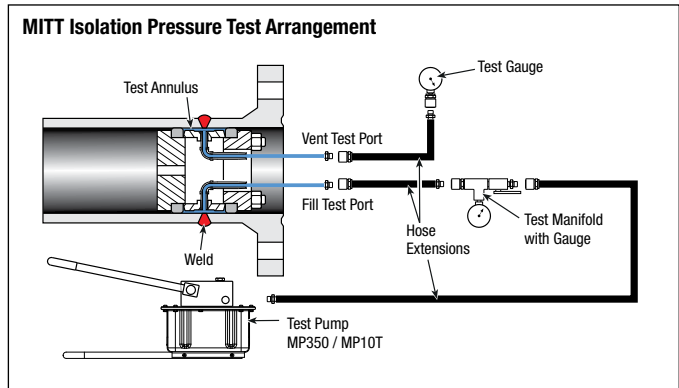
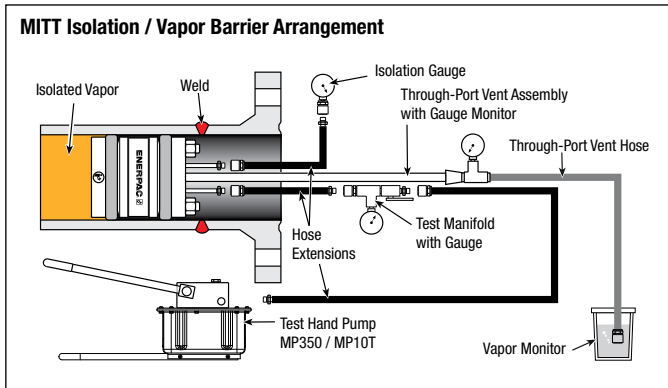

Nominal Pipe Diameter	Model Number	Pipe Schedules Covered	Max. Tool Pressure Rating	Tool Body Diameter	Overall Length	Stud, Nut, Washer Size	Pressure Port Size	Wt.
(in)			(psi)	(in)	(in)	(in)	(ASME NPT)	(lbs)
3/4	MITT075A	5, 10, STD/40	4500	0.7	14	1/8"	Female 1/8"	1.7
	MITT075B	XS/80, 160	4500	0.6	14	1/8"	Female 1/8"	1.5
1	MITT1A	5, 10, STD/40	4500	0.9	14	1/8"	Female 1/8"	1.9
	MITT1B	XS/80, 160	4500	0.7	14	1/8"	Female 1/8"	1.6
1 1/4	MITT125A	5, 10, STD/40 XS/80	4500	1.1	14	1/4"	Female 1/4"	2.9
1 1/2	MITT150A	5,10, XS/80	4500	1.4	14	1/4"	Female 1/4"	4.1
	MITT150B	160	4500	1.1	14	1/4"	Female 1/4"	3.4
2	MITT2A	5,10, STD/40, XS/80	4500	1.8	14	1/4"	Female 1/4"	5.4
	MITT2B	160, XXS	4500	1.4	14	1/4"	Female 1/4"	4.3
3	MITT3A	5,10, STD/40, XS/80	4500	2.8	7	3/8"	Male 1/8"	5
	MITT3B	160, XXS	4500	2.3	7	3/8"	Male 1/8"	4.5
4	MITT4A	5,10, STD/40, 60, XS/80	4500	3.7	7	5/16"	Male 1/8"	5.59
	MITT4B	120, 160	4500	3.2	7	5/16"	Male 1/8"	4.81
	MITT4C	XXS	4500	3.0	7	5/16"	Male 1/8"	4.25
6	MITT6A	10, STD/40, 60	4500	5.7	7	5/8"	Male 1/4"	13
	MITT6B	XS / 80, 120	4500	5.4	7	5/8"	Male 1/4"	12
	MITT6C	160, XXS	4500	4.8	7	5/8"	Male 1/4"	10
8	MITT8A	10, 20, 30, STD/40, XS/80	4500	7.4	7	5/8"	Male 1/4"	19
	MITT8B	100, 120, 140, XXS, 160	4500	6.6	7	5/8"	Male 1/4"	16
10	MITT10A	20, 30, STD/40, XS/60, 80	4500	9.4	7	5/8"	Male 1/4"	29
	MITT10B	100, 120, XXS/140, 160	4500	8.4	7	5/8"	Male 1/4"	25
12	MITT12A	10, 20, 30, STD, 40, XS	4500	11.6	7	5/8"	Male 1/4"	43
	MITT12B	60, 80, 100, XXS/120	4500	10.7	7	5/8"	Male 1/4"	41
	MITT12C	140, 160	4500	9.8	7	5/8"	Male 1/4"	32
14	MITT14A	10, 20, STD/30, 40	4500	12.8	7	5/8"	Male 1/4"	45
	MITT14B	XS, 60, 80	4500	12.8	7	5/8"	Male 1/4"	42
	MITT14C	100, 120, 140, 160	4500	11.1	7	5/8"	Male 1/4"	38
16	MITT16A	10, 20, STD/30, XS/40, 60	4500	14.6	7	5/8"	Male 1/4"	54
	MITT16B	80, 100	4500	13.6	7	5/8"	Male 1/4"	48
	MITT16C	120, 140, 160	4500	12.8	7	5/8"	Male 1/4"	45
18	MITT18A	10, 20, STD, 30, XS, 40	4500	16.5	7	5/8"	Male 1/4"	64
	MITT18B	60, 80	4500	15.8	7	5/8"	Male 1/4"	60
	MITT18C	100, 120	4500	14.9	7	5/8"	Male 1/4"	55
	MITT18D	140, 160	4500	14.1	7	5/8"	Male 1/4"	52
20	MITT20A	10, STD/20, XS / 30	4500	18.9	7	5/8"	Male 1/4"	80
	MITT20B	40, 60	4500	18.0	7	5/8"	Male 1/4"	73
	MITT20C	80, 100	4500	17.1	7	5/8"	Male 1/4"	67
	MITT20D	120, 140	4500	16.1	7	5/8"	Male 1/4"	61
	MITT20E	160	4500	15.7	7	5/8"	Male 1/4"	60
22	MITT22A	STD, XS	4500	20.6	7	5/8"	Male 1/4"	89
	MITT22B	60, 80	4500	19.4	7	5/8"	Male 1/4"	81
	MITT22C	100, 120	4500	18.4	7	5/8"	Male 1/4"	75
	MITT22D	140, 160	4500	17.4	7	5/8"	Male 1/4"	69
24	MITT24A	10, STD/20, XS, 30	1150	22.6	7	5/8"	Male 1/4"	99
	MITT24B	40, 60	2250	21.7	7	5/8"	Male 1/4"	94
	MITT24C	80, 100	3375	20.6	7	5/8"	Male 1/4"	88
	MITT24D	120, 140	4500	19.5	7	5/8"	Male 1/4"	82
	MITT24E	160	4500	18.9	7	5/8"	Male 1/4"	80
26	MITT26A	10, STD, XS	1150	24.6	7	55/8"	Male 1/4"	115
30	MITT30A	10, STD, XS/20, 30	1150	28.6	7	5/8"	Male 1/4"	147
	MITT30B	40	1150	28.1	7	5/8"	Male 1/4"	140
32	MITT32A	10, STD, XS/20, 30	1150	30.6	7	5/8"	Male 1/4"	158
	MITT32B	40	1150	30.3	7	5/8"	Male 1/4"	155
34	MITT34A	10, STD, XS/20, 30	425	32.6	7	5/8"	Male 1/4"	168
	MITT34B	40	425	32.2	7	5/8"	Male 1/4"	165
36	MITT36A	10, STD, XS	425	34.6	7	5/8"	Male 1/4"	187
38	MITT38A	STD, XS	425	36.6	7	5/8"	Male 1/4"	208
40	MITT40A	STD, XS	425	38.6	7	5/8"	Male 1/4"	230

MITT Series



Pipe Diameters:

3/4 - 40 inches

Water Capacity per Test:

0.10 - 0.75 gallon

Maximum Test Pressure:

4500 psi



Cost-Effective Spares

Buna 90 shore hardness seals and stainless steel seal backing rings provide additional pressure capacity for a low cost.



Ancillary Kit – MITTAK

All ancillary components required to safely isolate piping and test new welds (includes manual valves, gauge set, hoses, hand tools, fittings).



Pump and Reservoir

To match the full capability of the tools, the **MP350** hand pump and **MP10T** reservoir are recommended.

▼ MITT2A tool being torqued in a test stand for high-pressure testing.





Enerpac “Yellow Pages” *stand for* Hydraulic Information!

If selecting hydraulic equipment is not your daily routine then you will appreciate these pages. The “Yellow Pages” are designed to help you work with hydraulics. They will help you to better understand the basics of hydraulics, of system set-ups and of the most commonly used hydraulic techniques. The better your choice of equipment, the better you will appreciate hydraulics.

Take the time to go through these “Yellow Pages” and you will benefit even more from Enerpac High Pressure Hydraulics.



ENERPAC WARRANTY STATEMENT

Visit our website for the complete Global Lifetime Warranty or call your Authorized Service Center.



Learn More About Hydraulics

Visit www.enerpac.com to learn more about hydraulics and system set-ups.

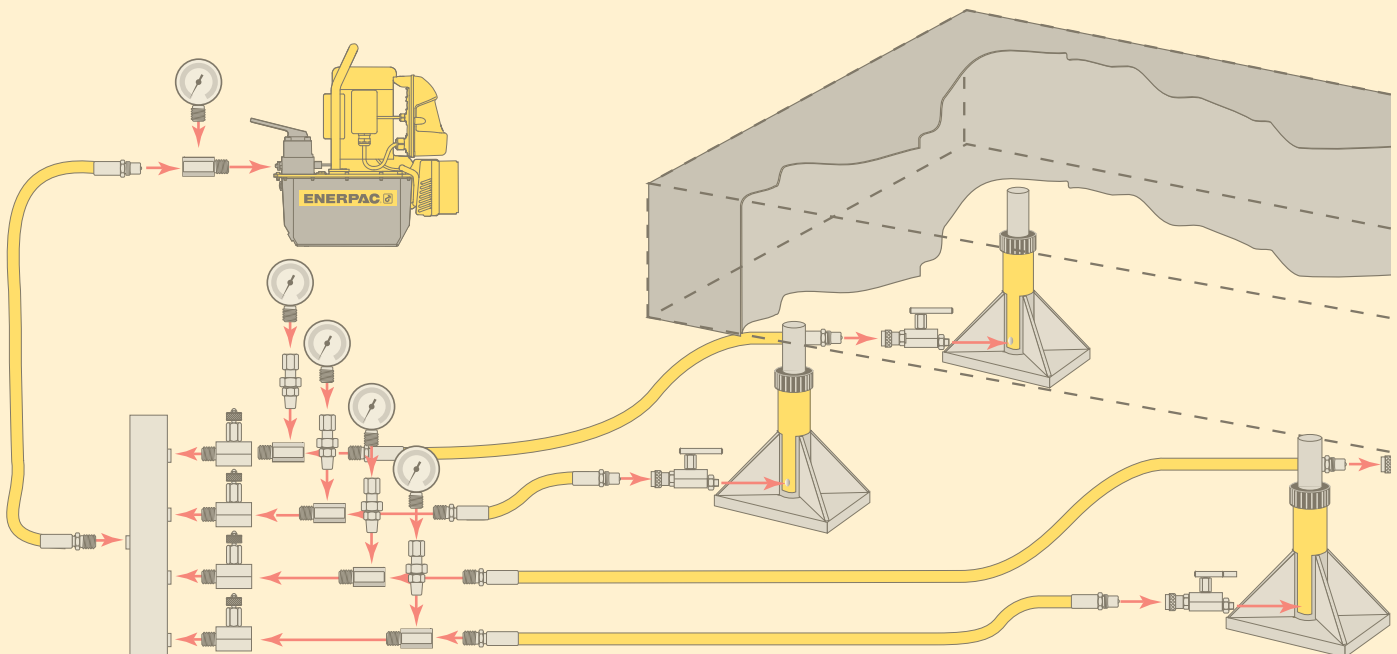
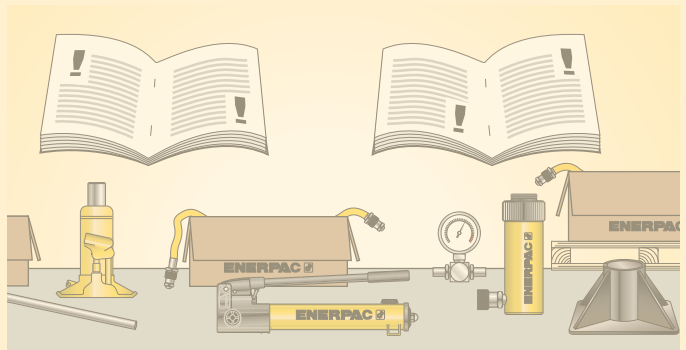



Section		Page
Safety Instructions		400-401 ▶
Product Selection & Worksheet		402-403 ▶
Basic System Set-ups		404-405 ▶
Basic Hydraulics		406-407 ▶
Conversion Tables and Speed Charts		408-409 ▶
Valve Information		410 ▶
Hexagon Bolt and Nut Sizes		411 ▶
Torque Tightening		412-415 ▶
Torque Tensioning		
Bolting Integrity Software		416-417 ▶



Enerpac is certified for several quality standards. These standards require compliance with standards for management, administration, product development and manufacturing.

Enerpac worked hard to earn the quality rating ISO9001, in its ongoing pursuit of excellence.

DIN-ISO 1402

Enerpac Thermoplastic and Rubber Hoses have been tested and confirm to this Standard.

ASME B30.1-2015

Our cylinders fully comply with the criteria set forth by the American Society of Mechanical Engineers (except RD, BRD, HCL, LPL, CUSP and JHA-Series).

Product Design Criteria

All hydraulic components are designed and tested to be safe for use at maximum 10,000 psi unless otherwise specifically noted.



Where specified, Enerpac electric power units meet the design, assembly and test requirements of The Standards Council of Canada (CAN C22.2 No. 68-92), and UL73 for the United States. Units were tested and certified for both USA and Canada by TÜV, and by CSA, USA-OSHA-NRTLs., (Nationally Recognized Testing Laboratories.)

EMC Directive

Where specified, Enerpac electric power pumps meet the requirements for Electromagnetic Compatibility per EMC Directive 2014/30/EU.

CE Marking & Conformity

Enerpac provides Declarations of Conformity or Incorporation, as applicable, and CE Marks for products according to the EU Directives.



ATEX 95 Certified

The S, W, DSX and HMT-Series torque wrenches, ZA, XA, LAT and ATP-Series air-driven pumps, SWI-Ex-flange spreaders, HP-EX hand pumps and the 144 type hoses are tested and certified according to the Directive 2014/34/EU "ATEX Directive".

The explosion protection is for Equipment Group II, Equipment Category 2 (Hazardous Zone Area 1 in Gas and/or Dust atmospheres).

- | | |
|----------------------|---|
| S, W-Wrenches: | Ex II 2 GD T4 |
| DSX, HMT-Wrenches: | Ex II 2 G c T6 |
| NSH-Nut Splitters: | Ex II 2 G c T6 |
| ZA4, ZA4T-Air Pumps: | Ex II 2 GD ck T4 |
| ZA4TX-QROP-Pumps: | Ex IIC T4 Gc
Ex IIIC T135°C Dc |
| ATP, XA-Air Pumps: | Ex II 2 GD ck T4: |
| LAT-Air Pumps: | Ex IIC T4 Gc and
Ex IIIC T135°C Dc |
| Swi-Ex Spreaders: | II 2G Ex h IIB T5 Gb and
II 2D Ex h IIIC T85°C Db |
| HP-Ex Hand Pumps: | II 2G Ex h IIB T5 Gb and
II 2D Ex h IIIC T100°C Db |
| 144 Hoses: | II 2G Ex h IIB T5 Gb and
II 2D Ex h IIIC T100°C Db |



When used correctly, hydraulic power is one of the safest methods of applying force to your work. To that end we offer

some DO's and DON'Ts, simple common sense points which apply to practically all Enerpac hydraulic products.

- Lift slowly and check often
- Avoid standing in the line of force
- Anticipate possible problems and take steps to avoid them

The illustrations and application photos of Enerpac products throughout this catalog are used to portray how some of our customers have used hydraulics in industry.

In designing similar systems, care must be taken to select the proper components that provide safe operation and fit your needs.

Check to see if all safety measures have been taken to avoid the risk of injury and property damage from your application or system.

Enerpac cannot be held responsible for damage or injury caused by unsafe use, maintenance or application of its products.

Please contact the Enerpac office or a representative for guidance when you are in doubt as to the proper safety precautions to be taken in designing and setting up your particular system.

In addition to these tips, every Enerpac product comes with specific safety information and instructions. Please read them carefully.

Jacks

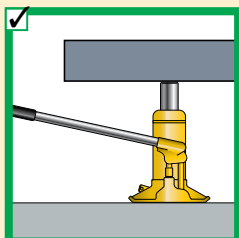
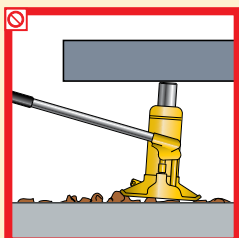

Provide a level and solid support for the entire jack base area.

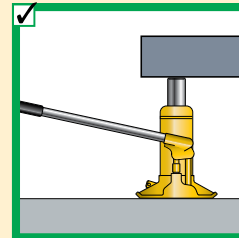
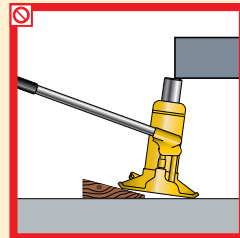

The entire jack saddle must be in contact with the load. Movement of the load must be in the same direction as jack plunger.



Never place any part of your body under the load. Ensure the load is on a solid support before venturing under.

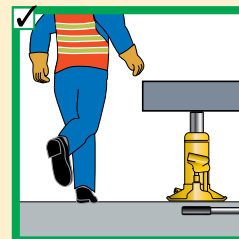
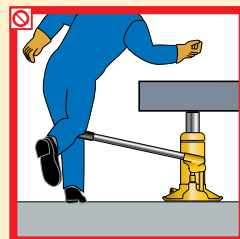

Remove the jack handle when it is not being used.

Cylinders

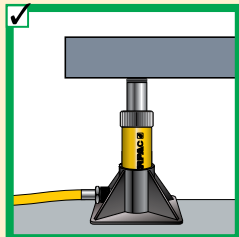
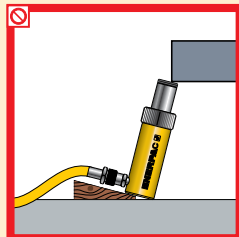

Provide a solid support for the entire cylinder base area. Use cylinder base attachment for more stability.

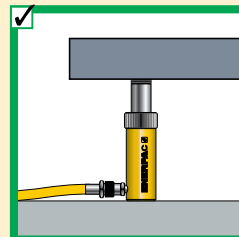
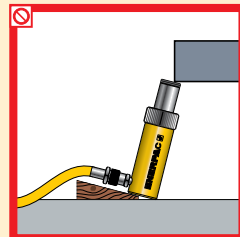

The entire cylinder saddle must be in contact with the load. Movement of the cylinder must be parallel with the movement of the load.

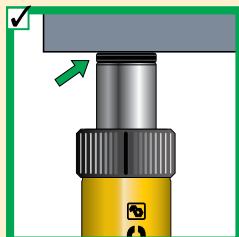
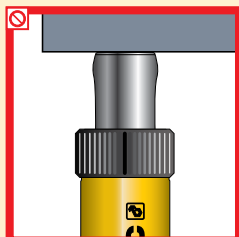

Do not use cylinder without saddle. This will cause plunger to "mushroom". Saddles distribute load evenly on the plunger.



As with jacks, never place any part of your body under the load. Load must be on cribbing before venturing under.



Always protect cylinder threads for use with attachments.

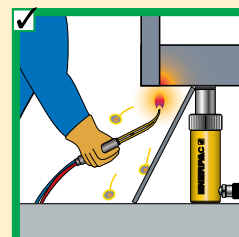

Keep hydraulic equipment away from open fire and temperatures above 150 °F (65 °C).



General

80% Manufacturer's rating of load and stroke are maximum safe limits. **80%**
Good practice encourages using only 80% of these ratings!

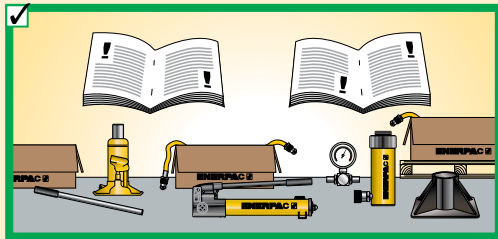

Always read instructions and safety warnings that come with your Enerpac hydraulic equipment.

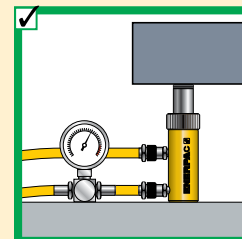
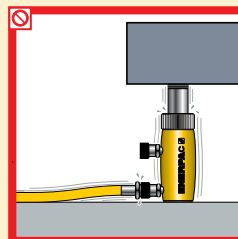

Both couplers must be connected when using double-acting cylinders. Ensure return hose is fitted.

Pumps

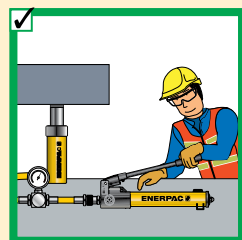
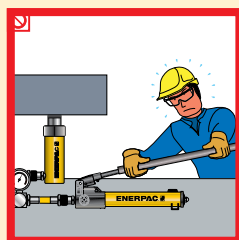

Don't use handle extenders. Hand pumps should be easy to operate when used correctly.

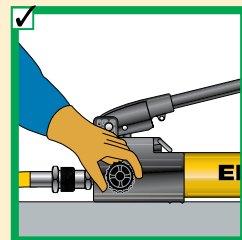
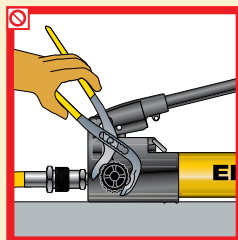

Close release valve finger tight. Using force will ruin the valve.

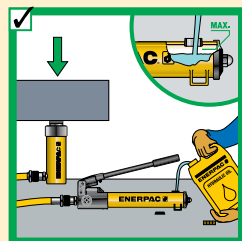
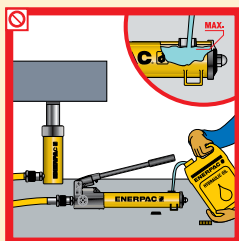

Fill pump only to recommended level. Fill only when connected cylinder is fully retracted.

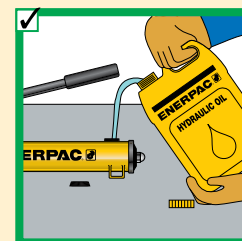
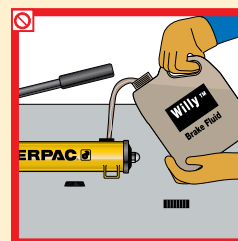

Always use genuine Enerpac hydraulic oil.

Hoses and couplers

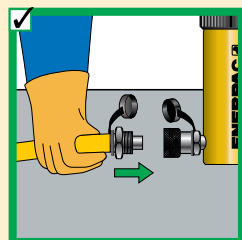
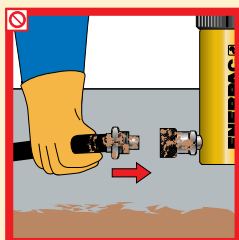

Clean both coupler parts before connecting. Use dust caps when coupler parts are not connected.

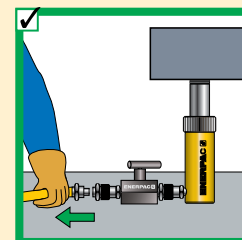
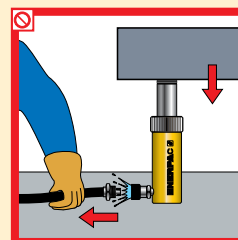

Detach cylinder only when fully retracted or use shut-off valves or safety valves to lock-in cylinder pressure.

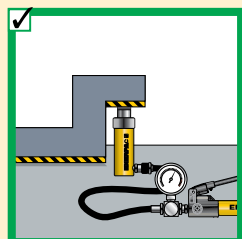
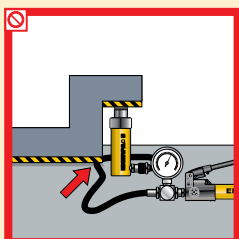

Keep hoses away from the area beneath loads.

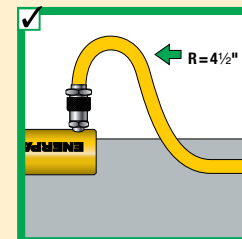
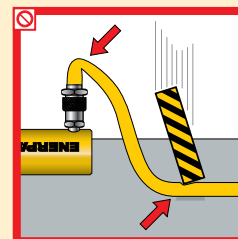

Don't kink hoses. Bending radius should be at least 4 1/2 inch. Don't drive over or drop heavy objects on hoses.

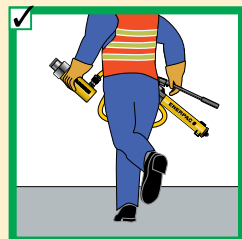
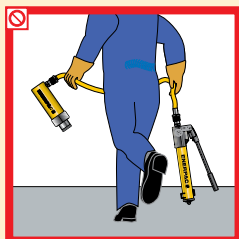



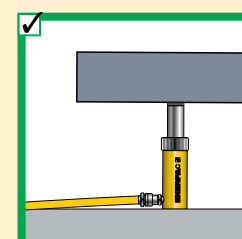
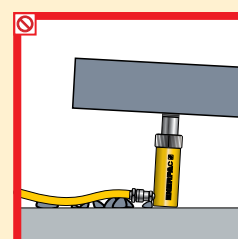

Don't lift hydraulic equipment by the hoses.



Never allow the cylinder to be lifted off of the ground through the couplers.









▼ HAND PUMP AND SINGLE-ACTING CYLINDER MATCHING CHART

Capacity (tons) ▶ ▼ Stroke (inches)	5 t	10 t	15 t	25 t	30 t	50 t	60 t	75 t	100 t	150 t
< 1.00										
1.00										
2.00										
3.00										
4.00										
5.00										
6.00										
7.00										
8.00										
9.00										
10.00										
12.00										
13.00										
14.00										
		P392			P80		P462			
		<i>Page:</i> 86			<i>Page:</i> 88		<i>Page:</i> 88			

Note: Selection based on oil capacity requirements of cylinders.

▼ POWER PUMP SELECTION CHART

Oil Flow*	Low (20 in ³ /min)		Medium (60 to 100 in ³ /min)		High (33 to 305 in ³ /min)	
Reservoir Oil Capacity	0.5-1 gal.	1.5 gal.	1.2-10.3 gal.	1.2-10.3 gal.	2.6-10.3 gal.	5, 10, 40 gal.
Duty Cycle**	Intermittent	Extended	Intermittent	Extended	Extended	Extended
Portable/Stationary***	Portable	Stationary	Portable	Stationary	Stationary	Stationary
Recommended Series	PU-Series Economy	E-Series E-Pulse®	ZU4-Series	ZE3-, ZE4- and ZE5-Series	ZE6-Series	SFP-Series
						
	<i>Page:</i> 101	<i>Page:</i> 102	<i>Page:</i> 106	<i>Page:</i> 112	<i>Page:</i> 112	<i>Page:</i> 132

* Oil Flow

- Determined by motor size
- Directly affects electrical power requirements
- Determines cylinder or tool speed

** Duty Cycle

- Extended applications require more than one hour of uninterrupted pump use
- Intermittent use – from 20 minutes to one hour, depending on reservoir capacity (contact Enerpac for details)

*** Portability

- | | |
|-------------------------------|----------------------------------|
| Portable | Stationary |
| • Ergonomic handles | • Mounting options |
| • Flexible power requirements | • Normally requires stable power |

Product Selection Worksheet



▼ Complete the following information to select the right products:

Cylinder Selection	Question:	Tips/help	Data	Model Number
	Total force required in tons:	Total load		
	Number of cylinders required:	Number of lifting points		
	Force per cylinder in tons:	Should be 80% of total cylinder cap.		
	Stroke required:	Plunger travel		
	Single or double acting (D/A):	D/A used when pull force is required, or retract speed is critical		
	Type of plunger required:	Hollow or solid		
	Collapsed height required:	Height with plunger fully retracted		
	Optional saddle required:	Tilt, Grooved, Flat		
	Cylinder base:	Improves stability		
	Cylinder attachments: (RC-series)	Expanded functions		
Selected cylinder model:			▶	
Including coupler model:				

Pump Selection

The three most commonly selected pumps are hand pumps, electric pumps and air-driven pumps. Gas powered pumps, however can be selected in the same way.

Available power source: Manual Battery Electric Compressed Air Gasoline

Hand pump
 Single- or double-acting operation
 Not for high-cycle applications
 Use 4-way valve for D/A applications
 Check speed chart on page 409 for number of strokes per inch

Selected hand pump: ▶

Electric or compressed air pump
 Need for portability: Weight and power requirements
 Duty cycle: Intermittent or extended
 Required usable oil capacity: Intermittent = 1.2 x cylinder oil capacity
 high cycle = 2 x cylinder oil capacity
 Available voltage: Single phase or Three phase
 Lifting speed (Important/not important): Use speed chart on page 409
 Type of control: Manual/remote pendant
 Type of actuation/function: Advance/hold/retract
 Accessories: Roll bar, Oil Filter kit, ...

Selected pump: ▶

To suit hose: Oil connection

System Components

Number of hoses and length required:

Selected hoses: ▶

Manifold or tee: ▶
 Extra hose per manifold (2): ▶
 Gauge (psi, lbs or tons scale): GF-series glycerine for high cycle ▶
 Gauge adaptor: ▶
 Fittings: ▶
 Pressure relief safety valve: ▶
 Load-holding valve(s): ▶
 Hydraulic oil: ▶



1 Cylinder

Applies hydraulic force.
Page 5

2 Cylinder Base Plate

For applications such as lifting where additional cylinder stability is required.
Page 10

3 Pump

Provides hydraulic flow.
Page 84

4 Hose

Transports hydraulic fluid.
Page 148-149

5 Male Coupler

For quick connection of the hose to system components.
Page 150-151

6 Female Coupler

For quick connection of the hose end to the system components (usually included with the cylinder).
Page 150-151

7 Gauge

To monitor pressure of the hydraulic circuit.
Page 156-157

8 Gauge Adaptor

For quick and easy gauge installation.
Page 162

9 Swivel Connector

Allows proper alignment of valves and/or gauges. Used when units being connected cannot be rotated.
Page 163

10 Auto-damper Valve V10

Used to protect gauge from damage due to sudden pulses in the system. Needs no adjustment and allows correct positioning of gauge, prior to tightening.
Page 164-165

11 4-Way Directional Control Valve

Controls the direction of hydraulic fluid in a double-acting system (usually included with the powerpack).
Page 164-165

Single-acting push application, such as in a press.
The hand pump offers controlled cylinder advance, but may require many hand pump strokes in longer stroke applications when the cylinder capacity is 25 ton or above.

Examples of pump, hose and cylinder sets can be found on page 62-65.

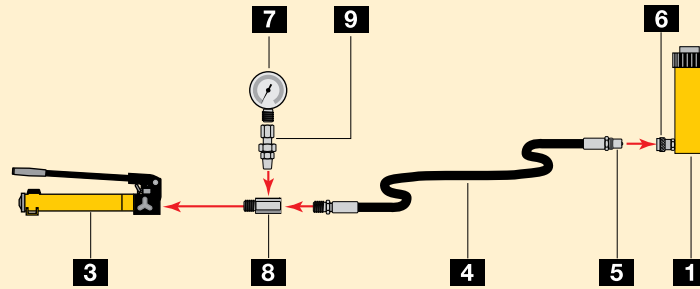

Single-acting cylinder with longer stroke used for lifting applications.

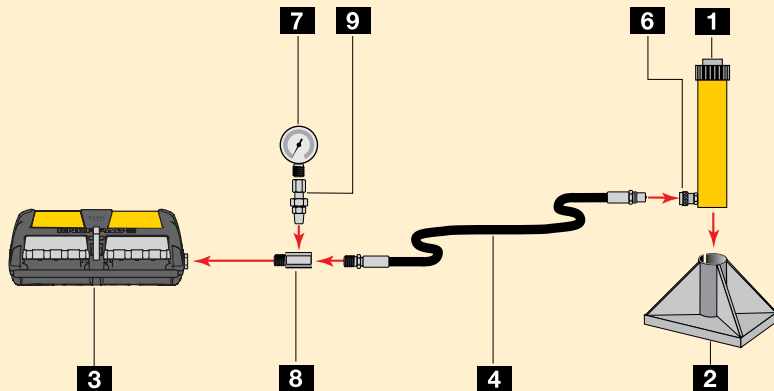

Double-acting cylinder set-up used for lifting applications where a slow controlled descent of the load must be maintained.

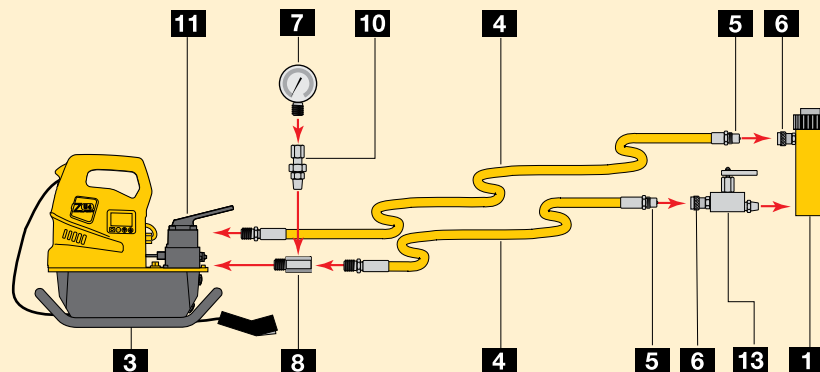



Double-acting cylinder set-up used in a push/pull application.

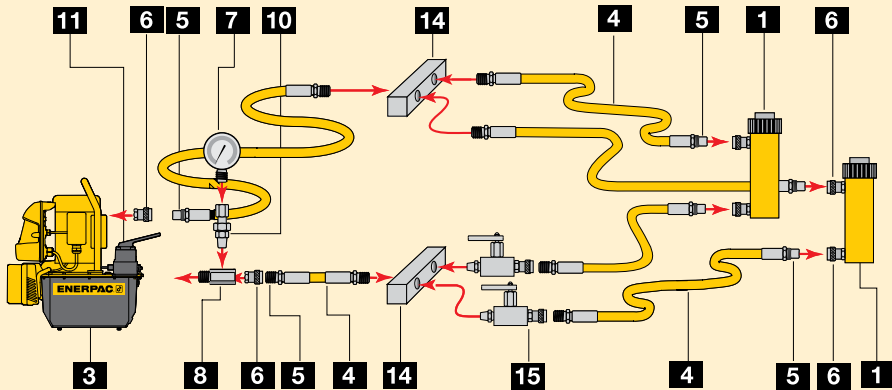

12 3-Way Directional Control Valve
Controls the direction of hydraulic fluid in a single-acting system (usually included with the powerpack).
Page 164-165

13 Safety Holding Valve
Holds the load in lifting applications.
Page 165

14 Manifold
Allows distribution of hydraulic fluid from one power source to several cylinders

Split-Flow Manifold
Allows distribution of hydraulic fluid from one power source to several single-acting cylinders
Page 152 & 154

15 Needle Valve
Regulates the flow of hydraulic fluid to or from the cylinders.
Page 165

Two point lifting set-up using single-acting cylinders.

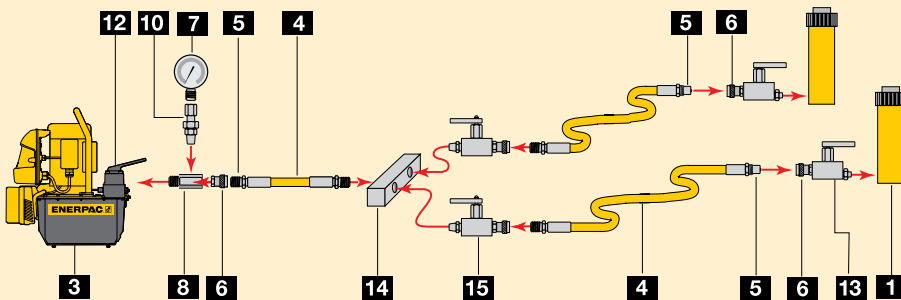

Four point lifting set-up, using single-acting cylinders, flow control valves and safety valves.

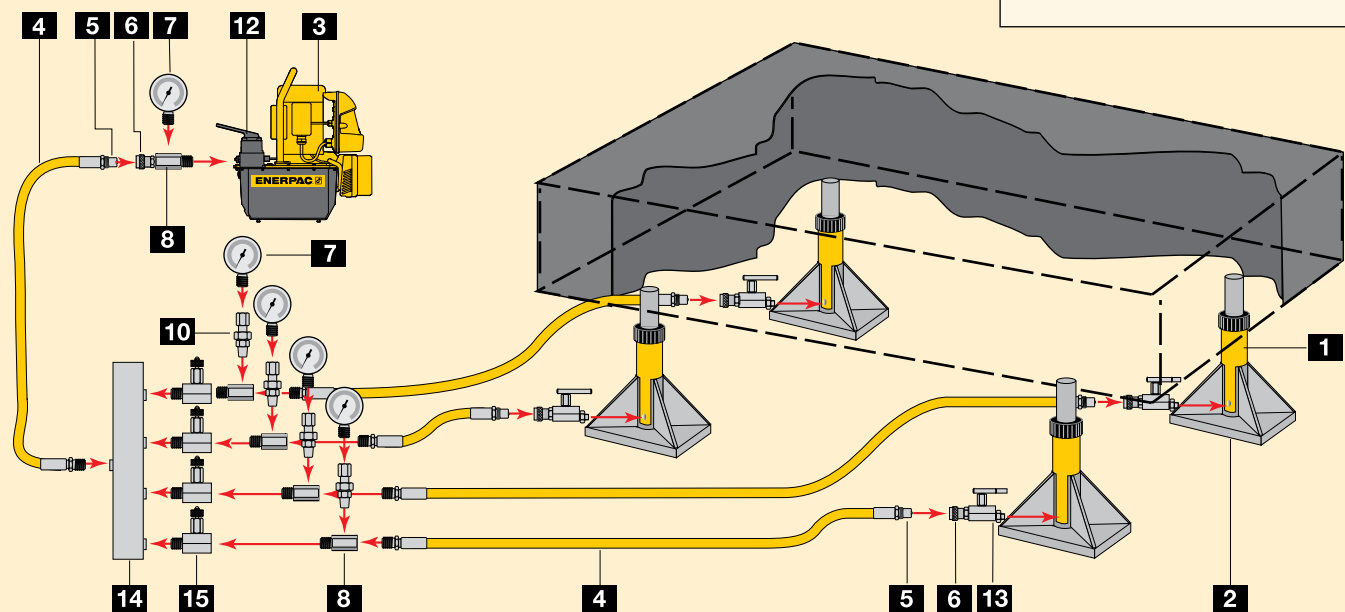



www.enerpac.com
Visit our web site to learn more about hydraulics and system set-ups.



Flow

A hydraulic pump produces flow

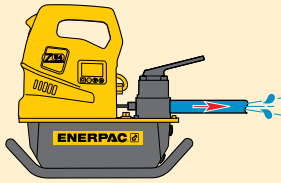

Pressure

Pressure occurs when there is resistance to flow

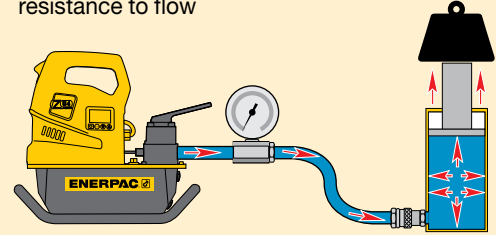

Pascal's Law

Pressure applied at any point upon a confined liquid is transmitted undiminished in all directions (Fig.1).

This means that when more than one hydraulic cylinder is being used, each cylinder will lift at its own rate, depending on the force required to move the load at that point (Fig. 2).

Cylinders with the lightest load will move first, and cylinders with the heaviest load will move last (Load A), as long as the cylinders have the same capacity.

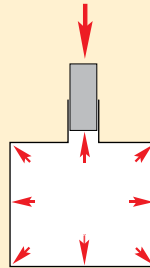
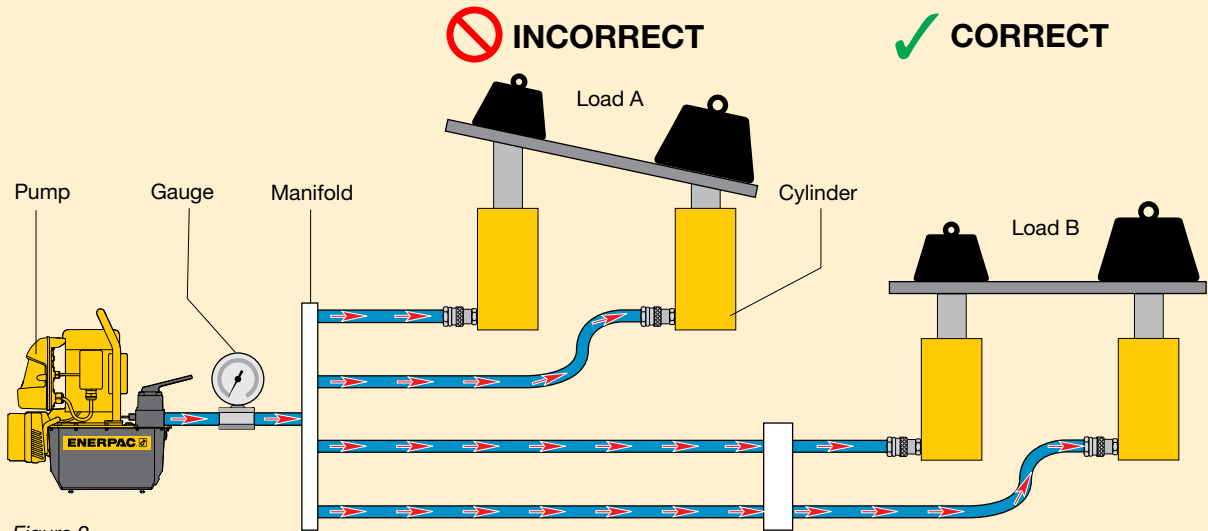

Figure 1

To have all cylinders operate uniformly so that the load is being lifted at the same rate at each point, either control valves (see Valve section) or Synchronous Lift System components (see Cylinder section) must be added to the system (Load B).



Synchronous Lift or Control Valves to provide uniform lifting of load.



CAUTION!

When lifting or pressing, always use a gauge.

A gauge is your "window" to the system. It lets you see what's going on. You will find the gauges in the System Components section.

Page: 147



Learn more about hydraulics

Visit www.enerpac.com to learn more about hydraulics and system set-ups.



Force

The amount of force a hydraulic cylinder can generate is equal to the hydraulic pressure times the “effective area” of the cylinder (see cylinder selection charts).

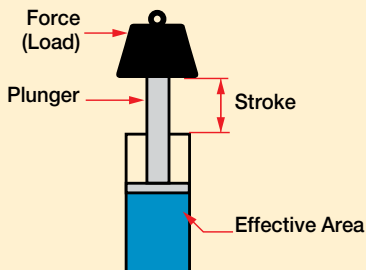

Force	=	Hydraulic Working Pressure	x	Cylinder Effective Area
-------	---	----------------------------	---	-------------------------

F	=	P	x	A
---	---	---	---	---

Use this formula to determine either force, pressure or effective area if two of the variables are known.

Example 1

An RC106 cylinder with 2.24 in² effective area operating at 8,000 psi will generate what force?

Force = 8,000 psi x 2.24 in² = 17,920 lbs.

Example 2

An RC106 cylinder lifting 14,000 lbs will require what pressure?

Pressure = 14,000 lbs ÷ 2.24 in² = 6,250 psi.

Example 3

An RC256 cylinder with 5.15 in² effective area is required to produce a force of 41,000 lbs. What pressure is required?

Pressure = 41,000 lbs. ÷ 5.15 in² = 7961 psi.

Example 4

Four RC308 cylinders each with 6.49 in² effective area are required to produce a force of 180,000 lbs. What pressure is required?

Pressure = 180,000 lbs ÷ (4 x 6.49 in²) = 6933 psi.

Remember, since four cylinders are used together, the area for one cylinder must be multiplied by the number of cylinders used.

Example 5

A HCL2506 cylinder with 56.27 in² effective area is going to be used with a power source that is capable of 7,500 psi. What is the theoretical force available from that cylinder?

Force = 7,500 psi x 56.27 in² = 422,025 lbs.

Cylinder Oil Capacity

The volume of oil required for a cylinder (cylinder oil capacity) is equal to the effective area of the cylinder times the stroke*.

Cylinder Oil Capacity	=	Cylinder Effective Area	x	Cylinder Stroke
-----------------------	---	-------------------------	---	-----------------

* **Note:** these are theoretical examples and do not take into account the compressibility of oil under high pressure.

Example 1

An RC158 cylinder with 3.14 in² effective area and an 8 in. stroke will require what volume of oil?

Oil Capacity = 3.14 in² x 8 in = 25.12 in³

Example 2

An RC5013 cylinder has an effective area of 11.05 in² and a stroke of 13.25 in. How much oil will be required?

Oil Capacity = 11.05 in² x 13.25 in = 146.41 in³

Example 3

An RC10010 cylinder has an effective area of 20.63 in² and a stroke of 10.25 in. How much oil will it require?

Oil Capacity = 20.63 in² x 10.25 in = 211.46 in³

Example 4

Four RC308 cylinders are being used, each with an effective area of 6.49 in² and stroke of 8.25 in. How much oil will be required?

Oil Capacity = 6.49 in² x 8.25 in = 53.54 in³ for one cylinder

Multiply by four to obtain the required capacity: 214.17 in³

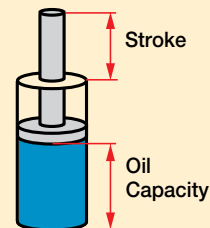

CAUTION!

Enerpac oil will compress 2.28% at 5,000 psi and 4.1% at 10,000 psi.

Page: 152



Key to cylinder dimensions

Dimensions shown in the Selection Charts of the cylinder section are identified on the relevant drawings by the capital letter references listed here: A for collapsed height through Z for depth of internal base thread.

- A = Collapsed height
- B = Extended height
- C = Cylinder body length
- D = Cylinder outside diameter
- D1 = Cylinder width
- E = Cylinder inside diameter (bore)
- F = Plunger rod diameter
- G = Oil inlet thread
- H = Cylinder bottom to advance port
- I = Cylinder top to retract port
- J = Saddle outside diameter
- K = Saddle protrusion from plunger
- L = Plunger center to side of base
- M = Mounting holes to plunger center
- N = Length of smaller cylinder part
- O = Plunger hole or thread of saddle
- P = Plunger thread length
- Q = Plunger outside thread (pull cylinders only)
- U = Bolt circle diameter of mounting holes
- V = Thread of cylinder mounting holes
- W = Collar thread
- X = Collar thread length
- Y = Center hole diameter (hollow cylinders only)
- Z = Depth of base hole thread

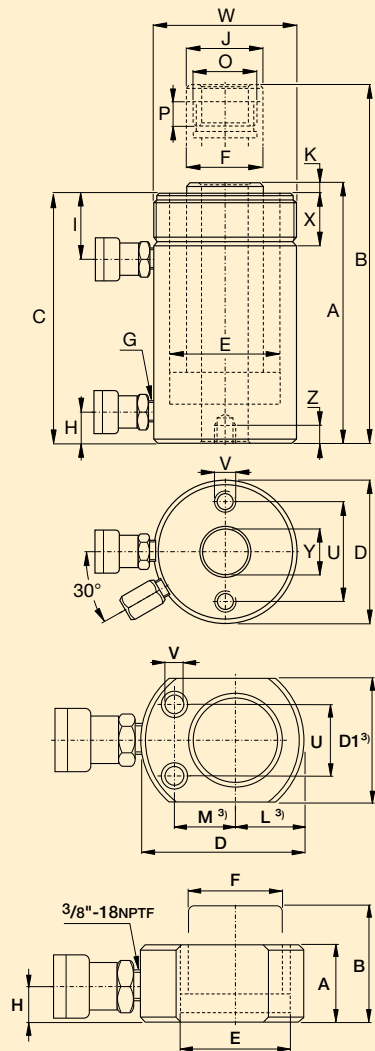

Key to measurements

All capacities and measurements in the catalog are expressed in uniform values.

The conversion chart provides helpful information for their translation into equivalent systems.

You can also visit our website at www.enerpac.com to download a FREE conversion calculator.

Pressure:

- 1 psi = 0.069 bar
- 1 bar = 14.50 psi
- 1 kPa = 0.145 psi

Volume:

- 1 in³ = 16.387 cm³
- 1 cm³ = 0.061 in³
- 1 liter = 61.02 in³
- 1 liter = 0.264 gal
- 1 US gal = 3,785 cm³
- = 3.785 l
- = 231 in³

Weight:

- 1 pound (lb) = 0.4536 kg
- 1 kg = 2.205 lbs
- 1 metric ton = 2,205 lbs
- 1 ton (short) = 2,000 lbs
- 1 ton (short) = 907.18 kg

Temperature:

- To convert °F to °C:
 $T_c = (T_f - 32) \div 1.8$
- To convert °C to °F:
 $T^F = (T_c \times 1.8) + 32$

Torque:

- 1 Ft.lbs = 1.356 Nm
- = 0.138 kgf.m
- 1 Nm = 0.738 Ft.lbs
- = 0.102 kgf.m

Other measurements:

- 1 in = 25.4 mm
- 1 mm = 0.039 in
- 1 in² = 6.452 cm²
- 1 cm² = 0.155 in²
- 1 hp = 0.735 kW
- 1 kW = 1.359 hp
- 1 Nm = 0.73756 Ft.lbs
- 1 Ft.lbs = 1.355818 Nm

Imperial to metric

Inches	Decimal	mm
1/16	0.06	1.59
1/8	0.13	3.18
3/16	0.19	4.76
1/4	0.25	6.35
5/16	0.31	7.94
3/8	0.38	9.53
7/16	0.44	11.11
1/2	0.50	12.70
9/16	0.56	14.29
5/8	0.63	15.88
11/16	0.69	17.46
3/4	0.75	19.05
13/16	0.81	20.64
7/8	0.88	22.23
15/16	0.94	23.81
1	1.00	25.40

Cylinder Speed Charts



Cylinder Speed

This chart will help you calculate the time required for an Enerpac cylinder to lift a load when powered by a 10,000 psi Enerpac hydraulic pump.

The Cylinder Speed Chart can also be used to determine the pump type and model best suited for an application when you know the plunger speed required.

To determine: Cylinder plunger speed

An RC-308 cylinder (30 ton) is powered by a ZE-5 pump. While lifting the load, the cylinder plunger will require 3.2 seconds to travel 1 inch. While extending towards the load, the cylinder plunger travels at 0.47 sec/in.

30 ton		50 ton		75 ton		100 ton		Pump Type	
No Load	Load	No Load	Load	No Load	Load	No Load	Load		
13.0	26.0	22.1	44.2	31.8	63.6	41.3	82.5	XC Series	
1.2	1.2	2.0	2.0	2.9	29.8	3.8	38.7	ZC3-Series	
1.8	1.2	3.0	20.7	4.3	29.8	5.6	38.7	E-Series, E-Pulse	
1.9	19.5	3.3	33.1	4.8	47.7	6.2	61.9	PU Economy	
1.0	9.7	1.7	16.6	2.5	23.9	3.2	30.9	ZE3-Series	
0.65	8.6	1.1	11.0	1.6	15.9	2.1	20.6	ZE4-Series	
0.47	3.2	0.47	3.2	0.47	3.2	0.47	3.2	ZE5-Series	
0.44	1.9	0.74	3.3	1.1	4.8	1.4	6.2	ZE6-Series	
0.73	6.5	1.2	11.0	1.8	15.9	2.3	20.6	ZU4-Series	
0.38	0.84	0.65	1.4	0.94	2.1	1.2	2.7	8000-Series, PE	
3.2	26.0	5.5	44.2	8.0	63.6	10.3	82.5	XA-Series	

To determine: Best matching pump

Your 30 ton cylinder needs to move a load at a speed of 6.50 sec/in. Simply go down from the top of the chart, to the value of 6.50 sec/in. Then follow the chart to the right to find that the ZE4 pump or ZU4 is most suitable for your application.

30 ton		50 ton		75 ton		100 ton		Pump Type	
No Load	Load	No Load	Load	No Load	Load	No Load	Load		
13.0	26.0	22.1	44.2	31.8	63.6	41.3	82.5	XC Series	
1.2	1.2	2.0	2.0	2.9	29.8	3.8	38.7	ZC3-Series	
1.8	1.2	3.0	20.7	4.3	29.8	5.6	38.7	E-Series, E-Pulse	
1.9	19.5	3.3	33.1	4.8	47.7	6.2	61.9	PU Economy	
1.0	9.7	1.7	16.6	2.5	23.9	3.2	30.9	ZE3-Series	
0.65	8.6	1.1	11.0	1.6	15.9	2.1	20.6	ZE4-Series	
0.47	3.2	0.80	5.5	1.2	8.0	1.5	10.3	ZE5-Series	
0.44	1.9	0.74	3.3	1.1	4.8	1.4	6.2	ZE6-Series	
0.73	6.5	1.2	11.0	1.8	15.9	2.3	20.6	ZU4-Series	
0.38	0.84	0.65	1.4	0.94	2.1	1.2	2.7	8000-Series, PE	
3.2	26.0	5.5	44.2	8.0	63.6	10.3	82.5	XA-Series	

Number of Pump Handle Strokes per Inch of Cylinder Plunger Travel

Cyl. Capacity ▶	5 ton		10 ton		15 ton		25 ton		30 ton		50 ton		75 ton		100 ton		Pump Type	Page
	No Load	Load	No Load	Load	No Load	Load	No Load	Load	No Load	Load	No Load	Load	No Load	Load	No Load	Load		
▼ Power Source Manual	18.0	18.0	40.7	40.7	57.1	57.1	93.8	93.8	118.0	118.0	200.7	200.7	289.1	289.1	375.1	375.1	P141	87
	6.6	6.6	14.9	14.9	20.9	20.9	34.4	34.4	43.3	43.3	73.6	73.6	106.0	106.0	137.5	137.5	P39	89
	6.6	6.6	14.8	14.8	20.8	20.8	34.2	34.2	43.0	43.0	73.1	73.1	105.3	105.3	136.6	136.6	P391	87
	4.5	18.0	10.1	40.7	14.2	57.1	23.3	93.8	29.4	118.0	50.0	200.7	71.9	289.1	93.3	375.1	P142/202	87
	1.4	6.6	3.3	14.8	4.6	20.8	7.5	34.2	9.4	43.0	16.1	73.1	23.1	105.3	30.0	136.6	P392	87
	1.0	6.6	2.2	14.9	3.1	20.9	5.2	34.4	6.5	43.3	11.0	73.6	15.9	106.0	20.6	137.5	P77/80/84/801	89
	0.4	6.6	0.9	14.8	1.3	20.8	2.2	34.2	2.7	43.0	4.6	73.1	6.6	105.3	8.6	136.6	P802/842	87
	0.1	3.4	0.3	7.7	0.4	10.8	0.7	17.8	0.8	22.4	1.4	38.1	2.1	54.8	2.7	71.1	P462/464	89

Seconds per Inch of Cylinder Plunger Travel

Cyl. Capacity ▶	5 ton		10 ton		15 ton		25 ton		30 ton		50 ton		75 ton		100 ton		Pump Type	Page	
	No Load	Load	No Load	Load	No Load	Load	No Load	Load	No Load	Load	No Load	Load	No Load	Load	No Load	Load			
▼ Power Source Electric (speed based on 60 Hz)	2.0	4.0	4.5	9.0	6.3	12.6	10.3	20.6	13.0	26.0	22.1	44.2	31.8	63.6	41.3	82.5	XC-Series	96-97	
	0.18	1.9	0.41	4.2	0.57	5.9	0.94	9.7	1.2	12.2	2.0	20.7	2.9	29.8	3.8	38.7	ZC3-Series	98-99	
	0.27	1.9	0.61	4.2	0.86	5.9	1.4	9.7	1.8	12.2	3.0	20.7	4.3	29.8	5.6	38.7	E-Series, E-Pulse	102-103	
	0.30	3.0	0.67	6.7	0.94	9.4	1.5	15.5	1.9	19.5	3.3	33.1	4.8	47.7	6.2	61.9	PU-Economy	100-101	
	* XC based on 28V battery	0.15	1.5	0.35	3.4	0.49	4.7	0.80	7.7	1.0	9.7	1.7	16.6	2.5	23.9	3.2	30.9	ZE3-Series	112-115
		0.10	1.0	0.22	2.2	0.31	3.1	0.52	5.2	0.65	6.5	1.1	11.0	1.6	15.9	2.1	20.6	ZE4-Series	112-115
		0.07	0.50	0.16	1.12	0.23	1.6	0.38	2.6	0.47	3.2	0.80	5.5	1.2	8.0	1.5	10.3	ZE5-Series	112-115
		0.07	0.30	0.15	0.67	0.21	0.94	0.35	1.5	0.44	1.9	0.74	3.3	1.1	4.8	1.4	6.2	ZE6-Series	112-115
Air (at 100 psi air pressure)	0.11	1.0	0.25	2.2	0.35	3.1	0.58	5.2	0.73	6.5	1.2	11.0	1.8	15.9	2.3	20.6	ZU4-Series	106-111	
	0.06	0.13	0.13	0.29	0.19	0.41	0.30	0.67	0.38	0.84	0.65	1.4	0.94	2.1	1.2	2.7	8000-Series, PE	118-119	
	0.05	4.0	1.1	9.0	1.6	12.6	2.6	20.6	3.2	26.0	5.5	44.2	8.0	63.6	10.3	82.5	XA-Series	124-125	
	1.0	5.9	2.2	13.4	3.1	18.8	5.2	30.9	6.5	39.0	11.0	66.3	15.9	95.5	20.6	123.9	Turbo II Pump	122-123	
Gasoline	1.2	7.4	2.7	16.8	3.8	23.6	6.2	38.6	7.8	48.7	13.3	82.9	19.1	119.3	24.8	154.7	PA133	120	
	0.09	6.6	0.21	14.9	0.29	20.9	.48	34.3	0.60	43.3	1.0	73.7	1.5	106.0	1.9	137.5	PAM-Series	121	
	0.07	0.74	0.16	1.7	0.22	2.4	.36	3.9	0.46	4.9	0.78	8.3	1.1	11.9	1.5	15.5	ZA4-Series	126-127	
Gasoline	0.08	0.59	0.19	1.3	0.27	1.9	0.44	3.1	0.56	3.9	0.95	6.6	1.4	9.5	1.8	12.4	ZG5-Series, Briggs	128-129	
	0.15	0.59	0.34	1.3	0.47	1.9	0.77	3.1	0.97	3.9	1.7	6.6	2.4	9.5	3.1	12.4	ZG5-Series, Honda	128-129	
	0.07	0.30	0.15	0.67	0.21	0.94	0.34	1.5	0.43	1.9	0.74	3.3	1.1	4.8	1.4	6.2	ZG6-Series	130	

No Load indicates the plunger speed as the plunger extends toward the load (1st stage).

Load indicates the plunger speed as the load is lifted at a system pressure of 10,000 psi (2nd stage).

Formula V = A ÷ Q

$$V \text{ (sec/in)} = A \text{ (in}^2\text{)} \div Q \text{ (in}^3\text{/min)}$$

V = Cylinder plunger speed in seconds per inch

A = Cylinder effective area in square inches

Q = Pump oil flow in cubic inches

Example: At what speed (V) will the RC308 (30 ton) cylinder move when powered by a ZE3 electric driven pump?

RC308 Cylinder effective area A = 6.50 in²

ZE3 pump oil flow Q, (no load) is 450 in³/min

$$V = 6.50 \text{ in}^2 \div 450 \text{ in}^3\text{/min} \times 60 = 0.87 \text{ sec/in}$$

$$\text{Cylinder Plunger Speed (sec/in)} = \frac{\text{Cylinder Effective Area}}{\text{Pump Flow Rate}} \times \frac{60 \text{ sec}}{1}$$



Ways

The (oil) ports on a valve.

A 3-way valve has 3 ports: pressure (P), tank (T), and cylinder (A).

A 4-way valve has 4 ports: pressure (P), tank (T), advance (A) and retract (B).

Single-acting cylinders require at least a 3-way valve, and can, under certain instances, be operated with a 4-way valve.

Double-acting cylinders require a 4-way valve, providing control of the flow to each cylinder port.

Positions

The number of control points a valve can provide. A 2-position valve has the ability to control only the advance or retraction of the cylinder. To be able to control the cylinder with a hold position, the valve requires a 3rd position.

Center Configuration

The center position of a valve is the position at which there is no movement required of the hydraulic component, whether a tool or cylinder.

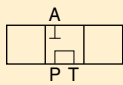

The most common is the **Tandem Center**. This configuration provides for little to no movement of the cylinder and the unloading of the pump. This provides for minimum heat build-up.

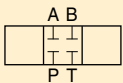

The next most common is the **Closed Center** configuration, which is used mostly for independent control of multi-cylinder applications. This configuration again provides for little to no movement of the cylinder, but also dead-heads the pump, isolating it from the circuit. Use of this type of valve may require some means of unloading the pump to prevent heat build-up.

There are many more types of valves, such as Open Center and Float Center. These valves are used mostly in complex hydraulic circuits and require other special considerations.

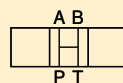

Open Center

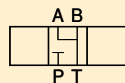

Float Center

Directional Control Valves

3-Way Valves are used with single-acting cylinders

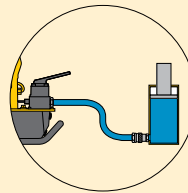

4-Way Valves are used with double-acting cylinders

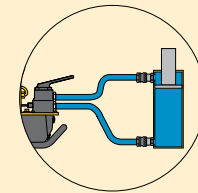

Valves may be either pump mounted or remote mounted.	Pump Mounted	Remote Mounted
Valves may be either manually or solenoid operated.	Manually Operated	Solenoid Operated

Advance Hold Retract

Single-acting cylinder

Controlled by a 3-way, 3-position valve.

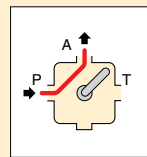

Advance

The oil flows from the pump pressure port P to the cylinder port A: the cylinder plunger will extend.

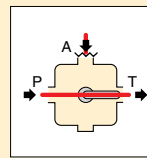

Hold

The oil flows from the pump pressure port P to the tank T. The cylinder port A is closed: the cylinder plunger will maintain its position.

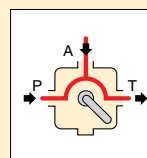

Retract

The oil flows from the pump port P and cylinder port A to the tank T: the cylinder plunger will retract.

Double-acting cylinder

Controlled by a 4-way, 3-position valve.

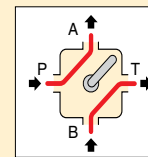

Advance

The oil flows from the pump pressure port P to the cylinder port A, and from cylinder port B to tank T: the cylinder plunger will extend.

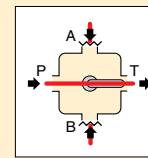

Hold

The oil flows from the pump pressure port P to the tank T. The cylinder ports A and B are closed: the cylinder plunger will maintain position.

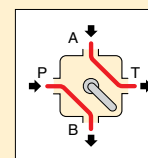

Retract

The oil flows from the pump pressure port P to cylinder port B, and from cylinder port A to tank T: the cylinder plunger will retract.

Hexagon Nut and Bolt Sizes



METRIC SIZES

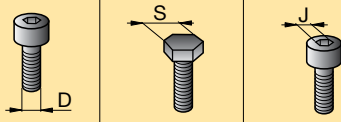

Thread Size D (mm)	Hexagon Size S (mm)	Hexagon Size J (mm)
M 10	17	8
M 12	19	10
M 14	22	12
M 16	24	14
M 18	27	14
M 20	30	17
M 22	32	17
M 24	36	19
M 27	41	19
M 30	46	22
M 33	50	24
M 36	55	27
M 39	60	27 (30)
M 42	65	32
M 45	70	-
M 48	75	36
M 52	80	36
M 56	85	41
M 60	90	46
M 64	95	46
M 68	100	50
M 72	105	55
M 76	110	60
M 80	115	65
M 85	120	70
M 90	130	70 (75)
M 95	135	-
M 100	145	85
M 105	150	-
M 110	155	-
M 115	165	-
M 120	170	-
M 125	180	-
M 130	185	-
M 140	200	-
M 150	210	-

IMERIAL SIZES

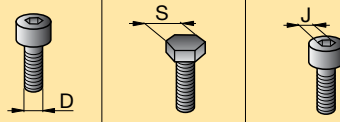

Thread Size D (in)	Hexagon Size * S (in)	Hexagon Size J (in)
5/8"	1 1/16"	1/2"
3/4"	1 1/4"	5/8"
7/8"	1 7/16"	3/4"
1"	1 5/8"	3/4"
1 1/8"	1 13/16"	7/8"
1 1/4"	2"	7/8"
1 3/8"	2 3/16"	1"
1 1/2"	2 3/8"	1"
1 5/8"	2 9/16"	-
1 3/4"	2 3/4"	1 1/4"
1 7/8"	2 15/16"	1 3/8"
2"	3 1/8"	1 5/8"
2 1/4"	3 1/2"	1 3/4"
2 1/2"	3 7/8"	1 7/8"
2 3/4"	4 1/4"	2"
3"	4 5/8"	2 1/4"
3 1/4"	5"	2 1/4"

* Heavy hexagon nuts.



Determine the maximum torque according to the bolt (nut) size and grade. Always consult the manufacturer's instructions or engineering recommendations when making bolted connections.



IMPORTANT

The hexagon sizes shown in the tables should be used as a guide only. Individual sizes should be checked before specifying any equipment.



BSH-Series Sockets

Use only Heavy Duty Impact Sockets for power driven torquing equipment, according to ISO2725 and ISO1174; DIN3129 and DIN3121 or ASME-B107.2/1995.



Tightening Methods

Principally there are two modes of tightening: "Uncontrolled" and "Controlled".

Uncontrolled tightening

Uses equipment and/or procedures that cannot be measured. Preload is applied to a bolt and nut assembly using a hammer and spanner or other types of impact tools.

Controlled tightening

Employs calibrated and measurable equipment, follows prescribed procedures and is carried out by trained personnel.

Advantages of Controlled Tightening

Known, controllable and accurate bolt loads

Employs tooling with controllable outputs and adopts calculation to determine the required tool settings.

Uniformity of bolt loading

Especially important on gasketed joints as an even and consistent compression is required for the gasket to be effective.

Safe operation following prescribed procedures

Eliminates the dangerous activities of manual uncontrolled tightening and requires that the operators be skilled and follow procedures.

Reduces operational time resulting in increased productivity

Reduces tightening time and operator fatigue by replacing manual effort with the use of controlled tooling.

Reliable and repeatable results

Using calibrated, tested equipment, following procedures and employing skilled operators achieves known results consistently.

The right results first time

Many of the uncertainties surrounding in-service joint failures are removed by ensuring the correct assembly and tightening of the joint are carried out the first time.



Bolting Integrity Software

A comprehensive on-line software solution for Bolted Joint integrity.

Integral databases hold data for:

- ASME B16.5, ASME B16.47, API 6A and API 17D flanged joints
- Common gasket materials and configurations
- Comprehensive range of bolt materials
- Comprehensive range of lubricants
- Enerpac's Controlled Bolting Equipment including: Torque Multipliers, Hydraulic Wrenches and Bolt Tensioning tools

Custom Joint information can also be entered.

The software offers Tool selection, Bolt Load calculations and Tool pressure settings, as well as, a combined Application data sheet and Joint completion report.

www.enerpac.com

What is Torque?

It is a measure of how much force acting on an object which causes that object to rotate.

What is Torque Tightening?

The application of preload to a fastener by the turning of the fastener's nut.

Torque Tightening and Preload

The amount of preload created when torquing is largely dependant on the effects of friction.

Principally there are three different "torque components":

- torque to stretch the bolt
- torque to overcome the friction in bolt and nut threads
- torque to overcome friction at the nut spot face (bearing contact surface).

Torque Tightening

Turning movement

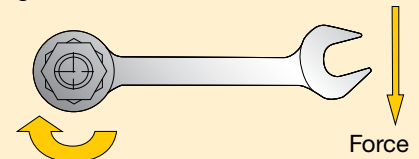

Stretch of Fastener (Pre-load)

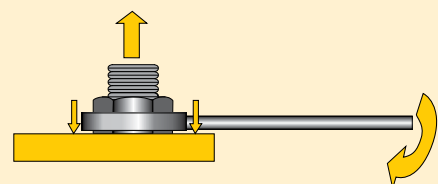



Preload (residual load) = Applied Torque *minus* Frictional Losses

Lubrication Reduces Friction

Lubrication reduces the friction during tightening, decreases bolt failure during installation and increases bolt service life. Variation in friction coefficients affect the amount of preload achieved at a specified torque. Higher friction results in less conversion of torque to preload. The value for the friction coefficient provided by the lubricant manufacturer must be known to accurately establish the required torque value.

Lubricant or anti-seize compounds should be applied to both the nut bearing surface and the male threads.

Frictional Losses

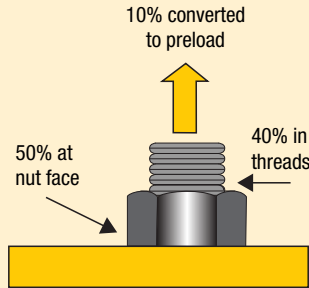

Frictional Losses (dry steel bolt)

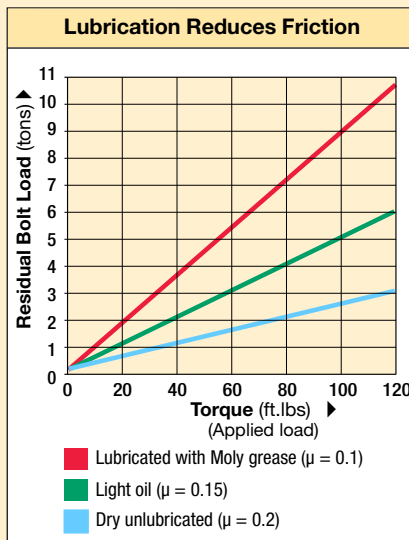

Example of how a lubricant can reduce the effect of friction and convert more torque to bolt preload.

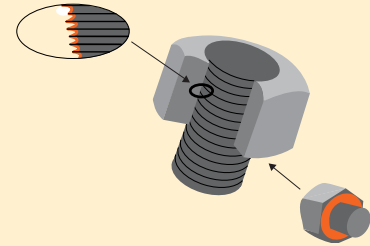

Friction points should always be lubricated when using the torque tightening method.



Select the Right Wrench

Choose your Enerpac torque wrench using the untightening rule of thumb:

- When loosening a nut or bolt more torque is usually required than when tightening.
- For general conditions it can take up to 2½ times the input torque to breakout.
- Do not apply more than 75% of the maximum torque output of the tool when loosening nuts or bolts.

Conditions of bolted joints

- Humidity corrosion (rust) requires up to twice the torque required for tightening.
- Sea water and chemical corrosion requires up to 2½ times the torque required for tightening.
- Heat corrosion requires up to 3 times the torque required for tightening.

Torque Procedure

When torquing it is common to tighten only one bolt at a time, this can result in Point Loading and Load Scatter. To avoid this, torque is applied in stages following a prescribed pattern:

Torque Sequence

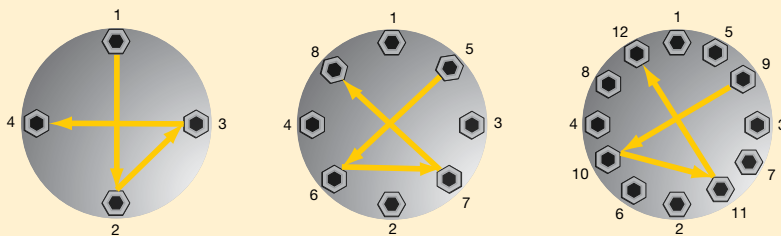

- Step 1** Spanner tight ensuring that 2 - 3 threads extend above nut.
- Step 2** Tighten each bolt to one-third of the final required torque following the pattern as shown above.
- Step 3** Increase the torque to two-thirds following the pattern shown above.

- Step 4** Increase the torque to full torque following the pattern shown above.
- Step 5** Perform one final pass on each bolt working clockwise from bolt 1, at the full final torque.



Breakout Torque

When loosening bolts a torque value higher than the tightening torque is normally required.

This is mainly due to corrosion and deformations in the bolt and nut threads.

Breakout torque cannot be accurately calculated, however, depending on conditions it can take up to 2½ times the input torque to breakout.

The use of penetrating oils or anti-seize products is always recommended when performing breakout operations.



Tensioning requires longer bolts



INCORRECT

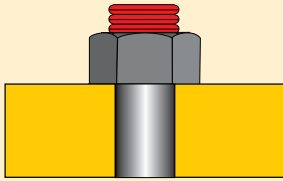

CORRECT

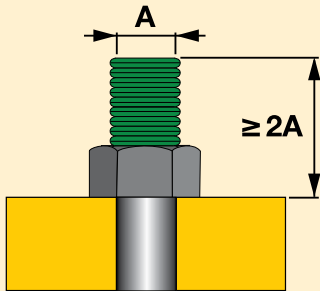

What is Bolt Tensioning?

Tensioning is the direct axial stretching of the bolt to achieve **preload**. Inaccuracies created through friction are eliminated. Massive mechanical effort to create torque is replaced with simple hydraulic pressure. A uniform load can be applied by tensioning multiple studs simultaneously.

Tensioning requires longer bolts, and a seating area on the assembly around the nut. Tensioning can be done using detachable Bolt Tensioners or Hydraulic Nuts.



Preload (residual load) = Applied Load minus Load Losses

What is Load Loss?

Load loss is a loss of bolt elongation depending on factors such as thread deflections, radial expansion of the nut, and embedding of the nut into the contact area of the joint. Load loss is accounted for in calculation and is added to the preload value to determine the initial **Applied Load**.

The preload depends on Applied Load and Load Loss (load loss factor).



GLOSSARY OF TERMS

Applied Load: The load applied to a bolt during tensioning which includes an allowance for Load Loss.

Bolt Tensioning: A method of controlled tightening which applies preload to a bolt by stretching it axially.

Breakout Torque: The amount of torque required to loosen a tightened bolt. (Usually more torque is required to loosen a bolt than was used to tighten it.)

Elastic Range: The range on a bolt's stress / strain curve where stress is directionally proportional to strain.

Load Loss: The losses in a bolt which occur on transfer of load from a tensioning device to the bolt assembly (these may arise from phenomena such as thread deflection and embedding of

the nut to the contact area of the joint, and is calculated as a factor of the length to diameter ratio of the bolt).

Load Scatter: The spread of differing loads in a sequence of bolts after they have been loaded. It is mostly due to the elastic interaction of the bolts and the joint member; as subsequently tightened bolts further compress the joint, previously tightened bolts are subject to some relaxation.

Plastic Range: The range on a stress/strain curve where the tensile load applied to a bolt results in permanent deformation.

Preload: The load in a bolt immediately after it has been tightened.

Proof Load: Proof load is often used interchangeably with Yield Strength but is usually measured at 0.2% plastic strain.

Tensile Point: The point at which the tensile loading on a bolt causes the bolt to rupture.

Torque Tightening: The application of Preload to a bolt by turning of the bolt's nut.

Ultimate Strength: The maximum tension which can be created by tensile load on a bolt.

Yield Strength: The point at which a bolt begins to plastically deform under tensile loading.

NOTE: Bolt is used as a generic term for a threaded fastener.



Manufacturer's rating of pressure and load are maximum safe limits. Good practice encourages using only 80% of these ratings!

Tensioning Operation

Tensioning permits the simultaneous tightening of multiple bolts; the tools are connected in sequence via a high-pressure hose assembly to a single pump unit. This ensures each tool develops the exact same load and provides a uniform clamping force across the joint. This is especially important for pressure containing vessels requiring even gasket compression to affect a seal.

General Procedure

- Step 1:** The bolt tensioner is fitted over the stud
- Step 2:** Hydraulic pressure is applied to the tensioner which then stretches the stud.
- Step 3:** The Stud's nut is wound down against the joint face
- Step 4:** Pressure is released and the tool removed.

The bolt behaves like a spring, when the pressure is released the bolt is under tension and attempts to contract, creating the required clamping force across the joint.

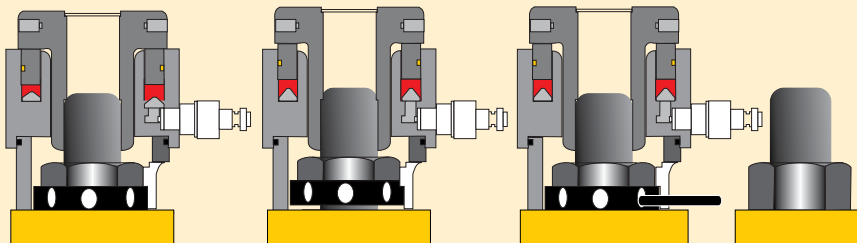

Step 1

Step 2

Step 3

Step 4

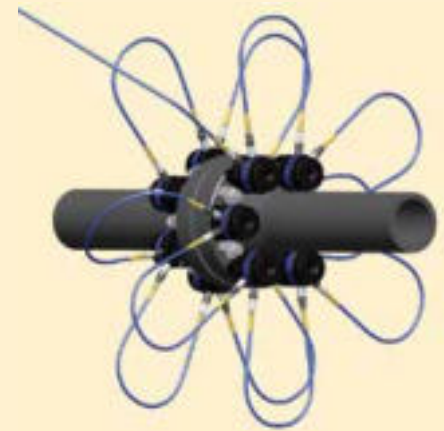

Set-up using a 100% tensioning procedure

All bolts are tensioned simultaneously.

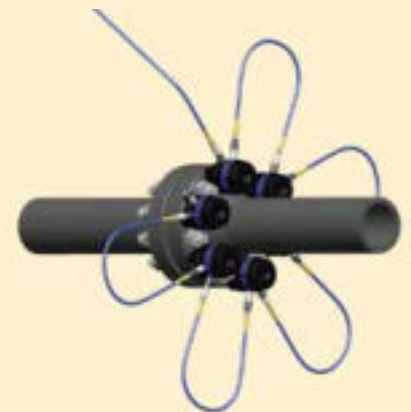

Set-up using a 50% tensioning procedure

Half the bolts are tensioned simultaneously, the tools are relocated on the remaining bolts and they are subsequently tensioned.

Less than 100% Tensioning

Not all applications allow for the simultaneous fit of a tensioning device on each bolt, in these cases at least two tensioning pressures are applied. This is to account for a load loss in those bolts already tensioned as the next sets are tightened. The load losses are accounted for in calculation and a higher load is applied to allow the first sets to relax back to the target preload.



Read Instruction Manuals

Please refer to the product Instruction Sheets for safe use guidelines and detail on the correct set up and operation of the equipment.



Enerpac Bolting Integrity Software Solutions play a key role in implementing and managing an Integrity Program for bolted connections. The software is used extensively within Enerpac and increasingly by a wide range of clients worldwide often interfacing with maintenance, construction and commissioning management systems.

- First developed over 20 years ago, we have continued to update and enhance the software based on user feedback, technology advances and our roles on industry standard committees, to produce the most comprehensive suite of joint integrity software available.
- Recommended bolt loads for standard joints are derived from independently verified calculation methods and traceable back to standards

Integral databases hold data for:

- ASME B16.5, ASME B16.47, API 6A and API 17D flanged joints
- Common gasket materials and configurations
- Comprehensive flange and bolt materials
- Comprehensive range of lubricants
- Enerpac controlled bolting equipment includes torque, multipliers, hydraulic wrenches and bolt tensioners.
- Custom joint information can also be entered.



▲ Standard flange calculation menu (INFORMATE)

The Enerpac Bolting Software Suite includes:

- **Bolt-Up** - Online bolt load calculator. Free access and use on www.enerpac.com.
- **INFORMATE** - Advanced calculation and procedure software. Contact Enerpac for user licenses and dedicated support.
- **iDMS Integrity Data Management System** - A complete Integrity Assurance project management package for managing bolted joints from cradle to grave. Contact Enerpac for user licenses and dedicated support.

Bolt-Up

Bolt-Up is a simple to use online calculator, built upon the Informate calculation engine, providing reliable, repeatable bolt loads for:

- Carbon steel weldneck ANSI 16.5 standard flanges, using a limited range of bolt materials; selected gasket options and a fixed lubrication value.
- Inputting basic joint configuration information allows Bolt-Up to determine: bolt load; bolt stress and the required torque. These outputs are displayed alongside basic flange and bolt information e.g. joint thickness and bolt size/quantity.



Bolting Integrity Software

The software offers Tool selection, Bolt Load calculations and Tool pressure settings, as well as, a combined Application data sheet and Joint completion report.

This software includes the following hydraulic tool selections:

- S, W, RSL, DSX and HMT Torque Wrenches,
- HM-Series HydraMax®, GT-Series Bolt Tensioners, and EAJ-Series AquaJack Subsea Tensioners

Software Model No.	INFORMATE Subscriptions
	Contact Enerpac for details
BS01PP	Bolting software 1 person purchase
BS01PAS	Bolting software 1 person annual support
BS05PP	Bolting software 5 person purchase
BS05PAS	Bolting software 5 person annual support

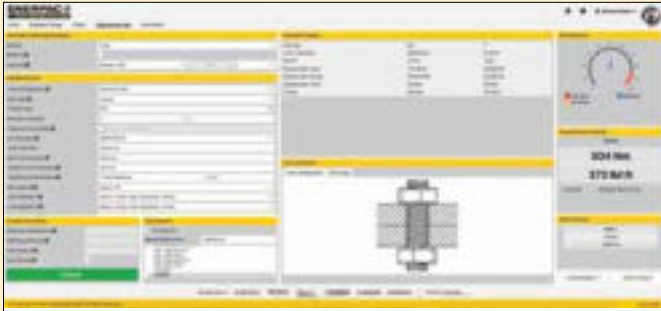

▲ Engineered Joint menu (INFORMATE)

INFORMATE Bolt Load Calculation Software

INFORMATE can be used on a huge range of flanged joints and clamped connections in virtually any situation from process piping to custom-designed flange connections.

- Calculate bolt loads and stresses, determine tooling pressures for Enerpac torque and tensioning equipment; analyse existing connections and test custom designed connections.
- Extensive material database covering all common standards:
 - Common and industry specific lubricants
 - 200+ bolting materials
 - 500+ flange materials
 - 60+ gasket materials
- Engineered Joint Calculation Features - allows for different types of bolted application for non-circular or structural applications.
- Installed direct to the desktop or accessed via the internet, Informate is available in a single version that is configurable to client requirements and includes multiple international standards and the latest and forthcoming regulatory data, when taken with a maintenance package.



▲ Clamp menu (INFORMATE)

Integrity Data Management System (iDMS)

iDMS is a flexible data management and activity planning system specifically for use on assets featuring bolted connections.

Designed to store the entire lifecycle data relating to every critical bolted joint on an installation, it aids planning, ensures joint integrity, as well as reducing construction and maintenance schedules and costs.

- Provides managers and technicians with essential information about joint components used in assembly, in addition it specifies the tools and the torque or tension values to deliver a leak-free joint.
- Allows planner and maintenance engineers to rapidly build packages of work complete with all documentation and then track them to completion
- Whenever a joint is worked on, all of the previous history and experience of that joint is available, allowing any particular requirements of the joint to be taken into account proactively prior to joint assembly and tightening.

iDMS Custom Tailored Solutions available to meet client needs, for example:

- Embedded Informate bolted joint calculator
- Export and import of data to asset management systems
- Exporting data to populate customer documentation
- Color coding of the joint provides an instant review of the status

Contact Enerpac for User License



The Enerpac Academy is our in-house training program, offering Enerpac product operators and maintenance staff the opportunity to be trained in the safe use and maintenance of high-pressure hydraulic tools.

Operating these tools requires sound knowledge of how they work and how they should be maintained. Correct use of these tools increases safety and reduces risk – both for the operator and the environment in which the tools are used. Having the right training enables the operator to use the tools safely and properly.



Enerpac Academy

- Safety focus for operators, tools and environment
- Dedicated in-house Enerpac training centers
- Both standard training courses and specialized training services
- Highly experienced training staff
- Develops alternative training options such as
 - eLearning modules
 - vLearning sessions
 - Instructional videos

In-house Training Centers



Do you work with high-pressure hydraulic tools on a regular basis or even every day? The training courses are designed to be highly interactive with a strong hands-on element. Each training course is led by a qualified trainer, an Enerpac specialist capable of providing high quality training. A written or practical exam is part of certain training courses.

Training Center Locations



- Columbus, Wisconsin (USA)
- Ede (The Netherlands)
- Bangalore (India)
- Singapore
- Perth (Australia)

Enerpac Academy offers a meticulously compiled training program covering tool knowledge, repairs and maintenance, and safe operation of Enerpac hydraulic tools. If you would like to schedule a training course, please contact Enerpac for a training calendar, application form, and brochure at www.enerpac.com.

The Power of Knowledge

In-Person Training



- Highly experienced training staff
- Class sizes range from 8 to 20, depending on class and location
- Commercial Sales, Service and Repair Class capabilities
- Most classes consist of theoretical and hands-on training

eLearning Modules



- Enerpac Training available on “your” schedule
- Courses available to support New Product Launches, Product Awareness Training and Enerpac Academy Courses
- Available to external viewers through Enerpac’s “LDMS” system

vLearning Sessions

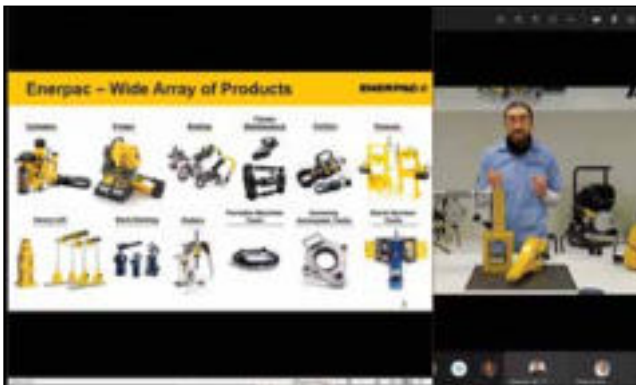

- Interactive training available on-line
- Sessions contain Technical Presentations, Hands-on product demos and end with a Q&A session
- Classes cover many topics, such as Product Operational information and Service & Repair Training
- Look for scheduling and registration details on www.Enerpac.com

Instructional Videos



- Informational videos created with Enerpac Academy Training processes in-mind
- Topics range from product “how-to” videos to application and operational videos
- Videos are available on the Enerpac “You-Tube” channel and other venues, where appropriate

<http://www.enerpac.com/en/enerpac-locations>

Australia and New Zealand

Actuant Australia Pty Ltd.
3 Orion Rd, Jandakot, WA 6164
Australia
Tel: +61 287 177 200
Fax: +61 297 438 648
Australia Toll Free: +1800 225 084
New Zealand Toll Free: +0800 363 772

Brazil

Power Packer do Brasil Ltda.
Rua Luiz Lawrie Reid, 548
09930-760 - Diadema (SP)-Brasil
Tel: +55 11 5687 2211
Toll Free: 0800 891 5770

China (Taicang)

Actuant (China) Industries Co.Ltd.
No. 6 Nanjing East Road,
Taicang Economic Dep Zone,
Jiangsu, China
T +86 0512 5328 7500
F +86 0512 5335 9690
Toll Free:
T +86 400 885 0369

Enerpac Heavy Lifting Technology B.V.

Zuidelijke Havenweg 3, 7554 RR Hengelo
P.O. Box 421, 7550 AK Hengelo
The Netherlands
T +31 74 242 20 45
F +31 74 243 03 38

France and French speaking Switzerland

ENERPAC France S.A.S.
6 rue du 4 septembre,
Immeuble Le Poversy, Bâtiment B - 6ème étage,
92130 Issy-les-Moulineaux, France
Tel: +33 1 60 13 68 68
Fax: +33 1 69 20 37 50

**Germany, Austria and
German speaking Switzerland**

Actuant GmbH
Boelckestrasse 21-23
D-50171 Kerpen, Germany
T +49 2237 92301-0
F +49 2237 9230-180

Central and Eastern Europe, Russia

Baltic States and CIS countries
Enerpac Eastern Europe Sp. z o.o.
Krakowska Street 280,
building: Eximius Park 200, floor 1,
32-080 Zabierzów, Poland

India

Enerpac India Private Limited
No. 10, Bellary Road, Sadashivanagar,
Bangalore, Karnataka - 560 080 India
T +91 80 3928 9000

Italy, Greece and Turkey

ENERPAC S.p.A.
Via Leonardo da Vinci, 97
20090 Trezzano sul Naviglio (Milano)
Italy
T +39 02 4861 111
F +39 02 4860 1288

Japan

Enerpac Co., Ltd.
Besshocho 85-7
Kita-ku, Saitama-shi 331-0821
Japan
T +81 48 662 4911
F +81 48 662 4955

**Middle East, North Africa
and Caspian Sea Countries**

ENERPAC Middle East FZE
Swiss Tower, Office 902, Cluster Y,
Jumeirah Lake Towers
Dubai-United Arab Emirates
Tel: +971 4 527 0700

Norway

ENERPAC AS
Kirkegata 3, NO-2000, Lillestrom
P.O. Box 3051, NO-2028, Lillestrom
Norway
Tel: +47 91 578 300

Southeast Asia, Hong Kong and Taiwan

25 Pandan Crescent
Tic Tech Centre
Singapore 128477
T +65 68 63 0611
F +65 64 84 5669
Toll Free:
T +1800 363 7722

South Korea

Actuant Korea Ltd.
48, Mayu-ro, 20-beon-gil, Shiheung-si
Gyeonggi-do, 15116 South Korea
T +82 31 434 4506
M +82 (0)10 7134 4508

Spain and Portugal

ENERPAC SPAIN, S.L.
Avenida Valdelaparra N° 27 3ª - L8
28108 Alcobendas (Madrid), Spain
T +34 91 884 86 06
F +34 91 884 86 11

**South Africa and other English speaking African
countries**

ENERPAC AFRICA (PTY) Ltd.
Cambridge Office Park, Block E
5 Bauhinia Avenue
Highveld Techno Park, Centurion 0157
Republic of South-Africa
T 0027 (0) 12 940 0656

Sweden, Denmark, Finland and Iceland

Enerpac Scandinavia AB
Box 83
82222 Alfta, Sweden
Tel: +46 (0) 415 000

The Netherlands, Belgium, Luxembourg

ENERPAC B.V.
Galvanistraat 115, 6716 AE Ede
P.O. Box 8097, 6710 AB Ede
The Netherlands
T +31 318 535 911
F +31 318 535 848

United Kingdom and Ireland

ENERPAC UK LTD
5 Coopies Field
Morpeth, Northumberland
NE61 6JR, England
T +44 800 1380 500
F +44 1670 5016 51

USA, Latin America and Caribbean

ENERPAC World Headquarters
P.O. Box 3241
Milwaukee, WI 53201-3241 USA
N86 W12500 Westbrook Crossing
Menomonee Falls, Wisconsin 53051
T +1 262 293 1600
F +1 262 293 7036
User inquiries:
+1 800 433 2766
Distributor inquiries/orders:
+1 800 558 0530
+1 800 628 0490

While every care has been taken in the preparation of this catalog and all data contained within is deemed accurate at the time of printing, Enerpac does reserve the right to make changes to the specifications of any product, or discontinue any product, contained within this catalog without prior notice.

All illustrations, performance specifications, weights and dimensions reflect the nominal values and slight variations may occur due to manufacturing tolerances. Please consult Enerpac if final dimensions are critical.

All information in this catalog can be changed due to product improvements without prior notice.

© Copyright 2021, Enerpac.

All rights reserved. Any copying or other use of material in this catalog (text, illustrations, drawings, photos) without express written consent is prohibited.

Model Number Index

A

A 151-153, 174-176, 217
 A5-A10 206-207
 A12 10
 A13-A28 206-207
 A29-A53 10
 A64-A66 152
 A92 217
 A102 10, 39
 A128-A192 206-207
 A152 10
 A185 206
 A200-A200R 176
 A205-A220 174-175
 A218 206-207
 A242-A305 206-207
 A252 10, 41
 A310, A330 174-175
 A530-A595 206-207
 A604 151
 A607 206-207
 A630 148-149, 151
 A650 206-207
 A92 217
 AD 39
 AH 148-149, 151
 AM 152-153
 AMGC 29, 152, 162
 AR 151
 ATM 330-331
 ATP 327
 AW 10

B

B 225, 325
 BC 225
 BFZ 153
 BH 325
 BHP 184-187, 193, 198
 BK 144
 BLJS 367
 BLS 72-73
 BR 325
 BRC 32-33
 BRP 32-33
 BS 391
 BSH 244
 BUS 245
 BW 325
 BZ 219

C

C 150-151
 CATS 10, 13, 15, 21, 27, 41
 49, 51, 53, 55, 57, 59
 CD 151
 CF 151
 CH 151, 236-237
 CHT 389
 CM 151, 216
 CR 151
 CULP 22
 CUSP 23
 CT 151
 CW 186

D

DDA 276
 DDU 393
 DGR 161
 DLR 382-383
 DSX 274-276

E

E 102-103, 284-285, 294-295
 EAJ 316-317
 EBC 225
 EBE 224
 EBH 222-223
 ECCE 228-229
 ECSE 233
 EDCH 226
 EFBE 227
 EGM 131
 ELB 214
 ELP 214-215
 EP 102-103, 290-291
 EPH 201
 ER 214-215
 ERA 269
 ERH 214
 ERT 269
 ES 214-215
 ETT 82
 ETR 370-371
 EVO 134, 136-137
 EWCE 232
 EWCH 230-231

F

F 150-151
 FC 355
 FF 340-341, 380
 FH 151
 FR 151
 FRL 286
 FS 332
 FSB 332
 FSC 332-333
 FSH 332-333
 FSM 332-337
 FTE 322-323
 FTR 320-321
 FZ 153

G

G 111, 158-159
 GA 162-163
 GBJ 67
 GF 156-157
 GeniSYS™ IV 394-395
 GKHC 226
 GMRF 387
 GP 156-157
 GPS 192
 GT 299, 314-315

H

H 148-149, 157, 158-159
 HA 149
 HB 149
 HC 149
 HCG 44-51
 HCL 44-47, 56-59
 HCR 44-47, 52-55
 HCRL 44-47, 60-61
 HF 152
 HLP 280-281
 HM 310-313
 HMT 278-279, 282-283
 HP 19, 35, 37, 357
 HPT 324
 HSK 360-361
 HSL 362-363
 HSQ 283

HT 325, 392
 HTM 388

I

IP 168-171, 177
 IPK 176
 IPL 176
 IPM 200
 IPR 172-173, 176

J

JBI 10
 JBA 13
 JH 66
 JHA 66
 JS 366-367

L

LAT 304-305
 LGH 195, 196-199
 LGHMS 199
 LGM 194-195
 LH 78-81, 180, 360-361
 LHPP 80
 LHSB 80
 LHST 81
 LMR 386
 LPHT 388
 LPL 24-25
 LSA 389
 LW / LWC 212
 LX 152

M

MCS 290
 MDWS 390
 MG 354
 MITT 396-397
 MHT 388
 MM 380-381
 MP 93
 MPS 191
 MR 386
 MRY 386
 MS 204-207
 MSP 209
 MZ 206-207

N

NC 334-335
 NCB 335
 NSC 336-337
 NSH 336-339
 NSPH 339
 NV 163

O

OM 384

P

P 64, 86-91, 94-95
 P142ALSS 64
 P392AL 87
 P392ALSS 64
 P392FP 92
 PA 120
 PAM 121
 PAMG 122-123
 PARG 122-123
 PATG 122-123
 PC 88, 120
 PEM 118-119

PER 118-119
 PGT 318-319
 PK 176
 PL 70-71
 PMB 176
 PR 68-69
 PTW 286-289
 PUD 100-101

R

RA 11
 RAC 12-13
 RACH 16-17
 RACL 14-15
 RARH 18-19
 RAR 20-21
 RB 10
 RC 6-9, 64
 RCH 34-35
 RCS 26-27
 RD 38-39
 REB 10
 REP 10
 RFL 122, 125
 RLP 264-271
 RL 28-29
 RL 40-43
 RRH 36-37
 RSL 262-273
 RSM 26-27
 RSQ 272-273
 RT 30-31
 RTE 243
 RW 184-186

S

S 240-242
 SB 337
 SBL 364-365
 SBZ 111, 116, 301, 309
 SC 62-63
 SCH 63
 SCJ 74-77
 SCL 63, 65
 SCR 63, 65
 SDA 242
 SFM 154-155
 SFP 132-135
 SG 191-192, 348-351
 SGH 188-189, 191
 SGM 188-190, 195, 199
 SHS 368-369
 SHAS 368-369
 SL 364-365
 SLPP 363
 SOH 213
 SP 209, 210-211
 SPD 208-209
 SPMT 372
 SRS 65, 243
 STB 218-219
 STC 234
 STF 333
 STN 334
 STP 209
 STTL 246-247
 SWH 240, 248, 258, 274
 SWi 344-347

T

T 150-151, 160, 393
 TFA 356
 TH 151
 THQ 259, 263, 272, 282
 TM 180
 TQ 296-297
 TR 151
 TSP 243, 260
 TWMP 269

V

V 64, 163-165
 VA2 121
 VB 179
 VC 142-143, 352-353
 VE 140-141, 143-145
 VLP 178-179
 VM 140-141, 143
 VM33RVK 141
 VS 144
 VUV5 141

W

W 248-257
 WCB 234-235
 WHC 234
 WHR 234
 WMC 235
 WP 385
 WR 217
 WRP 260
 WSL 258-259
 WTE 260

X

XA 124-125
 XC 96-97, 292-293
 XLK1 124
 XLP 178-179
 XSC1 124

Z

Z 151
 ZA4 126-127
 ZA4T 306-309
 ZC 98-99, 110, 11, 237
 ZE 112-117, 236-237, 302-303
 ZG 128-130
 ZH 110, 117, 301
 ZL 111, 116
 ZP 110-111, 116-117
 ZR 110, 116, 301, 309
 ZU4 106-111
 ZU4T 298-301
 ZUTP 328-329
 ZTM 301, 309

Numeric

11 94-95, 160
 41- 95
 43- 95, 160
 45- 95
 67- 353
 72-750 94
 83- 95, 160
 144- 357
 302- 357
 8000 118-119, 131

**Cylinders &
Lifting Products**



**Pumps &
Directional
Control Valves**



**System
Components &
Control Valves**



Presses



Pullers



Specialty Tools



Cutters



Bolting Tools



**Flange
Maintenance
Tools**



**Heavy Lifting
Technology**



**On-site
Machining
Tools**



EXTENSIVE GLOBAL DISTRIBUTION NETWORK

WHERE TO BUY THE RIGHT TOOLS

With over 1500+ distributors and 3500+ points of sale in over 100+ countries, Enerpac has a vast distribution network to reach all your local industrial tool needs.

Find on-demand access to application experts who can provide hands-on demonstrations, help with product selection or discuss rental options along with on-going service.



WORLD CLASS SUPPORT RESULTS IN THE RIGHT TOOL

Whether you're looking for help identifying the right product, receive technical support, training or request product materials, we have experts ready to answer your questions and provide guidance on the tool or accessory that will help get your toughest job done. Reach out to us at Enerpac.com/support.

VISIT STORE.ENERPAC.COM

Buy in person at your local Enerpac Tool Center or purchase select tools directly online.



GET THE LATEST VERSION