

INDUSTRIAL TOOLS

Cylinders
Lifting Products
Pumps
Control Valves
System Components
Presses
Pullers
Specialty Tools
Cutters
Bolting Tools
Flange Maintenance
Heavy Lifting Technology
On-site Machining



**400+ PAGES FILLED
WITH OVER 2000 TOOLS**

AU

E330a

Table of Contents

Introduction

The Right Tool 2-3

Cylinders & Lifting Products 4 - 73

Introduction & Overview 4 - 5

RC-Series, Single-Acting, General Purpose Cylinders 6 - 9

A, CAT, JBI, RB, RE-Series,
Cylinder Accessories for RC-cylinders 10

RA-Series, Aluminium Cylinders, Introduction 11

RAC-Series, Single-Acting, Aluminium Cylinders 12 - 13

RACL-Series, Single-Acting,
Aluminium Lock Nut Cylinders 14 - 15

RACH-Series, Single-Acting,
Aluminium Hollow Plunger Cylinders 16 - 17

RARH-Series, Double-Acting,
Aluminium Hollow Plunger Cylinders 18 - 19

RAR-Series, Double-Acting,
Aluminium Cylinders 20 - 21

CULP-Series, Ultra-Flat Cylinders with Stop Ring 22

CUSP-Series, Ultra-Flat Cylinders, High Tonnage 23

LPL-Series, Single-Acting,
Low-Height Lock Nut Cylinders 24 - 25

RSM, RCS-Series,
Single-Acting, Low-Height Cylinders 26 - 27

RLT-Series, Low-Height Telescopic Cylinders 28 - 29

RT-Series, Telescopic Cylinders 30 - 31

BRC, BRP-Series, Single-Acting, Pull Cylinders 32 - 33

RCH-Series, Single-Acting,
Hollow Plunger Cylinders 34 - 35

RRH-Series, Double-Acting,
Hollow Plunger Cylinders 36 - 37

BRD-Series, Double-Acting,
Precision Production Cylinders 38 - 39

RR-Series, Double-Acting,
Long Stroke Cylinders 40 - 43

High Tonnage Cylinders,
HCG, HCR, HCL, HCRL-Series, Introduction 44 - 45

Quick Selection 46 - 47

HCG-Series, Single-Acting, High Tonnage Cylinders 48 - 51

HCR-Series, Double-Acting,
High Tonnage Cylinders 52 - 55

HCL-Series, Single-Acting,
High Tonnage Lock Nut Cylinders 56 - 59

HCRL-Series, Double-Acting,
High Tonnage Lock Nut Cylinders 60 - 61

SC-Series, Cylinder-Pump Sets 62 - 63

P, RC, V-Series, Extreme Environment Products 64

SC, SL, SR, SW-Series, Power Box
Portable Tool Sets 65

JH, JHA-Series, Aluminium and Steel Jacks 66

GBJ-Series, Steel Bottle Jacks 67

PR-Series, POW'R-RISER® Mobile Lifting Jacks 68 - 69

PL-Series, POW'R-LOCK® Mobile Lifting Systems 70 - 71

Custom Hydraulic Cylinders 72

Overview Heavy Lifting Capabilities 73

Pumps & Directional Control Valves 74 - 125

Introduction & Overview 74 - 75

P-Series, Lightweight Hand Pumps 76 - 77

P-Series, Steel Hand Pumps 78 - 79

P-Series, Low Pressure Hand Pumps 80 - 81

MP-Series, Multifluid Hand Pumps 82

P-Series, Foot Pump 83

P, 11-Series, Ultra-High Pressure Hand Pumps 84 - 85

XC-Series, Cordless Hydraulic Pumps, portable 86 - 87

ZC-Series, Cordless Hydraulic Pumps 88 - 89

PU-Series, Economy Electric Pumps 90 - 91

ZE2-Series, Electric Pumps 92 - 93

E-Series, E-Pulse® Electric Pumps 94 - 95

Z-Class Power Pumps Introduction 96 - 97

ZU4-Series, Portable Electric Pumps 98 - 103

ZE-Series, Electric Pumps 104 - 109

PA-Series, Air Hydraulic Foot Pumps 110

PAM-Series, Air Hydraulic Pumps 111

PATG-Series, Turbo II, Air Hydraulic Pumps 112 - 113

XA-Series, Air Driven Foot Pumps 114 - 115

ZA4-Series, Modular Air Hydraulic Pumps 116 - 117

ZG-Series, Gasoline Hydraulic Pumps 118 - 119

Custom Hydraulic Pumps 120

Directional Control Valves 121 - 125

Introduction & Overview 121

VM, VE-Series, Pump Mounted Valves 122 - 123

VC-Series, Remote Mounted Valves 124 - 125

VC, VM, VE-Series, Valve Dimensions 125

System Components & Control Valves 126 - 145

Introduction & Overview 126 - 127

H700-Series, High Pressure Hoses 128 - 129

A, C, F, T-Series, Hydraulic Couplers 130 - 131

HF-Series, Hydraulic Oil 132

A, AM-Series, Manifolds 132

AMGC-Series, 4-Way Manifold Assemblies 132

FZ, BFZ, XSC-Series, Fittings 133

SFM-Series, Split-Flow Manifolds 134 - 135

GF, GP-Series, Force & Pressure Gauges 136 - 137

G, H-Series, Pressure Gauges 138 - 139

T-Series, Test System Gauges 140

DGR-Series, Digital Pressure Gauge 141

GA45GC-Series, Gauge Adaptor Assembly 142

GA, NV, V-Series, Gauge Accessories 143

V-Series, Pressure and Flow Control Valves 144 - 145

Hydraulic Presses 146 - 157

Introduction & Overview 146 - 147

IP-Series, H-Frame Presses 148 - 151

IPR-Series, Roll-Frame Presses 152 - 153

A-Series, C-Clamp and Arbor Presses 154 - 155

VLP-Series, Bench Presses 154 - 155

Custom Hydraulic Presses 156

TM-Series, Tension Meter 157

LH-Series, Load Cells 157

Pullers 158 - 177

Introduction & Overview 158 - 159

BHP-Series, Master and Grip Puller Sets 160 - 161

BHP-Series, Cross Bearing Puller Sets 162 - 163

BHP-Series, Bearing Cup and Bearing Pullers 164

IPM-Series, Mechanical Internal & Extrenal Puller 165

LGM-Series, Mechanical Lock-Grip Pullers 166 - 167

LGH-Series, Hydraulic Lock-Grip Pullers 168 - 169

LGHMS-Series, Master Lock-Grip Pullers 170 - 171

SGM-Series, Mechanical Sync-Grip Pullers 172 - 174

SGH, MPS, GPS-Series,
Hydraulic Sync-Grip Pullers 172, 175 - 177

Specialty Tools 178 - 199

Introduction & Overview 178 - 179

MS-Series, Maintenance Sets 180 - 183

SP-Series, Lightweight 35 ton Hydraulic Punch 184 - 185

SP-Series, 50 ton Double-Acting Punch 186 - 187

LW-Series, Hydraulic Vertical Lifting Wedge 188

SOH-Series, Hydraulic Machine Lifts 189

MLS-Series, Wheeled Machine Skates 190 - 191

EL, ER, ES-Series, Chain Roller Machine Skates 192 - 193

CM-Series, Industrial Storage Cases 194

A-Series, Wedgie 195

WR-Series, Spread Cylinders 195

STB-Series, Pipe Bender Sets 196 - 197

RP-Series, Hydraulic Rail Stressor 198 - 199

Cutters 200 - 217

Introduction & Overview 200 - 201

EB-Series, Bar Cutters 202

EBH-Series, Hydraulic Bar Cutters 203

EBE-Series, Electric Bar Cutters 204

EBC-Series, Cordless Bar Cutters 205

EDCH-Series, Decommissioning Cutters 206

EFBE-Series, Electric Flat Bar Cutters 207

ECCE-Series, Electric Chain Cutters 208 - 209

EWCH-Series, Hydraulic Wire and Cable Cutters 210 - 211

EWCE-Series Electric Wire and Cable Cutters 212

ECSE-Series, Cutter/Spreader Combination Tools 213

WHC, WHR-Series, Hydraulic Cutterheads 214

WMC-Series, Self-Contained Hydraulic Cutters 215

ZC, ZE, CH-Series Pumps & Hoses for Cutters 216 - 217

Bolting Tools and Pumps 218 - 325

Introduction & Overview 218 - 219

S-Series, Square Drive Torque Wrenches 220 - 223

BSH-Series, Heavy-Duty Impact Sockets 224

BUS-Series, Back-Up Spanners 225

STTL-Series, Safe T™ Torque Lock 226 - 227

W-Series, Hexagon Hydraulic Torque Wrenches 228 - 240

W-SL-Series, Ultra-Slim Hexagonal Cassettes 238 - 239

TSP, WTE, WRP-Series, Accessories for W-Series 240

Custom Torque Wrenches & Bolt Tensioners 241

RSL-Series, Hydraulic Torque Wrenches 242 - 253

RSL-Series, Hexagon Cassettes for RSL 244 - 248

ERA, ERT, TWM-Series, Accessories for RSL 249

RSL-Series, Slimline Hexagon Cassettes 250 - 251

RSQ-Series, Square Drive Cassettes 252 - 253

DSX-Series, Square Drive Torque Wrenches 254 - 256

THQ-Series, Twin Torque Wrench Hoses 257

HMT-Series, Modular Torque Wrenches 258 - 263

HLP-Series, Hexagon Cassettes for HMT 260 - 261

HSQ Square Drive Torque Wrenches 262 - 263

E-Series, Manual Torque Multipliers 264 - 265

PTW-Series, Pneumatic Torque Wrenches 266 - 269

STTC-Series, Safe T™ Torque Checker 270 - 271

MCS-Series, Mobile Calibration System 272

Optimum Wrench-Pump-Hose Combinations 273

XC-Series, Cordless Torque Pumps 274 - 275

E-Series, E-Pulse® Electric Torque Pumps 276 - 277

TQ-Series, Electric Torque Pumps 278 - 279

ZU4T-Series, Electric Torque Pumps 280 - 283

ZET-Series, Electric Torque Pumps 284 - 285

LAT-Series, Air Hydraulic Torque Pump 286 - 287

ZA4T-Series, Air Driven Torque Pumps 288 - 293

Bolt Tensioners & Pumps (1500 bar) 294 - 313

HM-Series, Hydramax Topside Bolt Tensioners 294 - 297

GT-Series, Topside Bolt Tensioners 298 - 299

EAJ-Series, Aquajack Subsea Tensioners 300 - 301

PGT-Series, Power Generation Bolt Tensioners 302 - 303

FTR-Series, Foundation Bolt Tensioners 304 - 305

FTE-Series, Foundation Bolt Tensioners 306 - 307

HPT-Series, Tensioning Hand Pump 308

HT, B-Series, Hoses, Couplers, Hose Reels,
T-Pieces, Y-Pipe Assemblies 309

ZUTP-Series, Electric Tensioning Pump 310

ATP-Series, Ultra-High Pressure Air Pump 311

Multi Stud Tensioning (MST) 312

Hydraulic Nuts (HN) 313

Joint Assembly & Separation 314 - 325

ATM-Series, Flange Alignment Tools 314 - 315

FSC, FSH, FSM-Series, Wedge Spreaders 316 - 317

NC-Series, Hydraulic Nut Splitters 318 - 319

NSC, NSH-Series, Hydraulic Nut Splitters 320 - 321

NSH-Series, Hydraulic Nut Splitters 322 - 323

FF-Series, Mechanical Pipe Flange Face Tool 324 - 325

Flange Maintenance Tools 326 - 341

Introduction & Overview 326 - 327

SWI-Series, Flange Spreading Tools 328 - 329

SWI-EX-Series, Flange Spreading Tools. ATEX 330 - 331

SG-Series, Flange Spreading Tools 332 - 335

VC-Series, Valve Change-Out Tools 336 - 337

MG-Series, Flange Spreading Tool 338

FC-Series, Flange Pulling & Closing Tools 339

TFA-Series, Wind Tower Flange Alignment Tools 340

HP-Series, Hydraulic Sealed Hand Pumps 341

1440, 3027-Series, Hydraulic Hoses 341

Heavy Lifting Technology	342 - 383
Introduction & Overview	342 - 343
SFP-Series, Electric Split-Flow Pumps	344 - 347
EVOP-Series, Synchronous Lifting Systems	
Pump-per-Point SyncLift	348 - 349
EVO-Series, Synchronous Lifting Systems	
Multifunctional SyncLift Pumps	350 - 351
SCJ-Series, Self-Locking Cube Jacks	352 - 355
BLS-Series, Climbing Jacks	356 - 257
JS-Series, Jack-Up Systems	358 - 359
HSL-Series, Heavy Lifting Strand Jacks	360 - 361
SHS, SHAS-Series, SyncHoist,	
Synchronous Hoisting Systems	362 - 363
ML-Series, Mini-Lift Hydraulic Gantries	364 - 365
SL, SBL-Series, Telescopic Hydraulic Gantries	366 - 367
LH-Series, Low-Height Skidding System	368 - 371
HSK-Series, Skidding Systems	372 - 373
ETR-Series, Electric Trolley Systems	374 - 375
ETT-Series, Hydraulic Turntables	376
SPMT-Series,	
Self-Propelled Modular Transporters	377
Custom Heavy Lifting Solutions	378
Lifting Solutions from Enerpac	379
Solution Consultations	380
Design & Manufacturing	381
Testing and Training	382
On-Demand Support	383
On-site Machining Tools	384 - 403
Introduction & Overview	384 - 385
FF, MM-Series, Flange Facing Machines	386 - 387
DLR-Series, Clamshell Pipe Cutting	
and Beveling Machines	388 - 389
OM-Series, General Orbital Milling Machines	390
WP-Series, Wind Power Orbital Milling Machines	391
LMR, MR, MRY, GM-Series,	
Linear Milling Machines	392 - 393
HTM, LPH, MHT, CHT-Series,	
Hot Tapping Machines	394 - 385
LSA-Series, Line Stop Actuators	395
MWDS-Series, Decommissioning Diamond Wire Saws	396
BS-Series, On-site Band Saws	397
HT, T, DDU-Series, Drilling & Tapping Machines	398 - 399
GeniSYS IV Portable 3-axis CNC Mill	400 - 401
MITT-Series, Isolation & Test Tools	402 - 403
Yellow Pages	404 - 424
Introduction & Overview	404 - 405
Safety Instructions	406 - 407
Pump Selection	408
Selection Worksheet	409
Basic System Set-ups	410 - 411
Basic Hydraulics	412 - 413
Conversion Tables	414
Cylinder Speed Charts	415
Valve Information	416
Hexagon Nut and Bolt Sizes	417
Torque Tightening	418 - 419
Bolt Tensioning	420 - 421
INFORMATE Bolting Integrity Software	422 - 423
Enerpac Academy	424
Enerpac Maintenance Program (EMP)	424

Worldwide Catalogue Coverage

Enerpac catalogues are printed in many languages. If your requirements call for product use in a different country, please send your request to the applicable country listed on enerpac.com

The Enerpac catalogue of the country serving your specific market area will be forwarded promptly.

Enerpac Worldwide Locations

www.enerpac.com/en-gb/contact/e/locations

While every care has been taken in the preparation of this catalogue and all data contained within is deemed accurate at the time of printing, Enerpac does reserve the right to make changes to the specifications of any product, or discontinue any product, contained within this catalogue without prior notice. All illustrations, performance specifications, weights and dimensions reflect the nominal values and slight variations may occur due to manufacturing tolerances. Please consult Enerpac if final dimensions are critical.

All information in this catalogue can be changed due to product improvements without prior notice. © Copyright 2022, Enerpac. All rights reserved.

Any copying or other use of material in this catalogue (text, illustrations, drawings, photo's) without express written consent is prohibited.



Cylinders & Lifting Products

Page 4-73



Pumps & Directional Valves

Page 74-125



System Components & Control Valves

Page 126-145



Presses

Page 146-157



Pullers

Page 158-177



Specialty Tools

Page 178-199



Cutters

Page 200-217



Bolting Tools

Page 218-325



Flange Maintenance Tools

Page 326-341



Heavy Lifting Technology

Page 342-383



On-site Machining Tools

Page 384-403

**CUSTOMER-DRIVEN
INNOVATION**

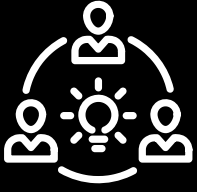

**INDUSTRY LEADING
TECHNOLOGY**

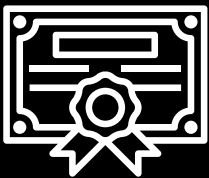

**CONTINUOUS
IMPROVEMENT**

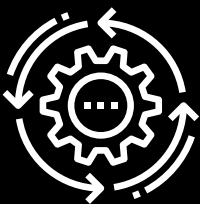

ENDLESS INNOVATION RESULTS IN THE RIGHT TOOL

We believe it takes advanced technical expertise and ingenuity to develop the industry's most trusted solutions. Our relentless pursuit to deliver the highest standard of excellence means never compromising on quality. Yet, it all starts with a thorough understanding of our customer needs, the environments they work in and the ideas of tomorrow that help get jobs done faster, easier and safer.

SOLVING CUSTOMER PROBLEMS

One of our core values is to continually innovate and solve customer problems. That all begins with the discovery process. Through the efforts of a dedicated innovation team and several centers of excellence, new ideas are uncovered by listening to our customer's pain points and observing how they perform tasks in their own environments. These inputs lead to the forming of ideas and eventually prototypes that can be tested, refined and transformed into finished products.

FIND OUR NEWEST PRODUCTS AT...

enerpac.com/innovation

Continuous improvement means new products are introduced and made available to customers on a regular basis throughout the year. Find the newest Enerpac products at Enerpac.com/innovation.

THE RIGHT TOOL MAKES ALL THE DIFFERENCE

Backed by a global legacy of ultra-reliable quality and superior precision, Enerpac is pushing the industry forward with a wide range of advanced industrial tools and services that first and foremost ensure our customers operate safely and productively every day. It isn't about being compliant. Or "as good" as the next guy; we outpace the competition by delivering technically superior solutions that are easy to get, safe to use and built to outlast.

NEVER COMPROMISE

Enerpac combines technical excellence with proven performance – every day, every year, year after year. We believe customers shouldn't have to compromise – they can rest easy knowing that even in the most complex situations, their reputations and productivity are protected by the most trusted industrial tools available.

SAFETY AND PRODUCTIVITY

Our customers put their physical well-being and reputations on the line each day they go to work; we take the fact that they put their trust in us very seriously. Enerpac team members are obsessively committed to developing solutions that keep the world's workers safe and productive in highly demanding working conditions.

ON-DEMAND ACCESS

For us, offering the ideal customer experience means working overtime to make sure our customers can be heroes when it matters most by providing on-demand access to a vast catalog of products and services, extensive training and mobilized field teams no matter where they are in the world.

As a global market leader in high-pressure hydraulic tools, controlled force products and solutions for precision positioning of heavy loads, Enerpac products have maintained and moved some of the largest structures on earth. They are the industry standard in aerospace, infrastructure, manufacturing, mining, oil & gas, power generation and much more.

110
YEARS OF HISTORY

~2600
EMPLOYEES

100+
COUNTRIES

2500+
DISTRIBUTORS

3500+
POINTS OF SALE



Enerpac hydraulic cylinders are available in hundreds of different configurations. Whatever the industrial application... lifting, pushing, pulling, bending, holding... whatever the force capacity, stroke length, or size restrictions... single- or double-acting, solid or hollow plunger, you can be sure that Enerpac has the cylinder to suit your high force application. Enerpac jacking cylinders fully comply to ASME B30.1 (except BRD-Series).



With the 3rd Generation comes a trio of key features

The next evolution of the legendary Enerpac RC-Series hydraulic cylinder. The driving force of the Enerpac cylinder range, the new **RC-TRIO** is as **versatile** as ever. Featuring a new Trio Bearing System for **enhanced durability** and a hybrid spring-return system for **faster retraction** and even **greater productivity**.

System for **enhanced durability** and a hybrid spring-return system for **faster retraction** and even **greater productivity**.

NEW RC-TRIO SERIES CYLINDERS

New TRIO Bearing System

- Includes up to 4 high-performance wear bands that offer increased resistance to damage, reducing bearing load and increasing cylinder lifespan.
- Hardened composite material wear bands increase bearing surface area for greater sideload resistance - Significantly improving cylinder life.
- New high-performance Polyethylene seals last longer than ever, improving lifespan and keep you working for longer.

New TRIO Stop Ring

- Part of the Trio Bearing System, the Trio Stop Ring includes an additional wear band or high-strength bronze to absorb greater side load
- Capable of taking full cylinder extension force
- Features durable wiper to help prevent contamination from entering the cylinder during retract cycles.

New TRIO Spring System

- Hybrid pre-tensioned return springs for up to 3x faster retraction and increased productivity.
- High-strength steel wire improves spring life
- Spring retention design improves serviceability while allowing higher pre-load during assembly
- Spring is easily removed without special tools.

Durable Piston Rod

- High-strength steel plunger for improved life and sideload resistance
- Nickel-plated plunger coating improves corrosion protection
- Internal plunger threads for easy tool fixturing.

Enhanced Ergonomics

- Standard carry handles on cylinders from 15 up to 25 kg. Sizes above include certified lifting eyes or optional handles.
- Collar threads, plunger threads and base mounting holes enable easy fixturing (on most models).



Improved Saddle Retention

- Hardened plunger saddle protects plunger end during all lifting operations
- Easily removable for access to plunger mounting threads
- Tilt and smooth saddles available as accessories (compatible with new range of CATS-Series Tilt Saddles).







































Enduring Compatibility

- For full compatibility and peace of mind, the new RC-Series model numbers, external dimensions and threads remain unchanged from prior RC-Series cylinders. Ensuring compatibility with historical versions and systems.



Note: The cut-away drawing is representative of typical cylinder construction, and may not represent all cylinders in this section.

Hydraulic Cylinders and Lifting Products Section Overview

Capacity ¹⁾ ton (kN)	Stroke Range (mm)	Cylinder Type and Functions	Series	Page
5 - 95 (45 - 933)	16 - 362	General Purpose Cylinders, Single-Acting Accessories: Saddles, Base Plates, Mounting Blocks, Clevis Eyes	 RC A, CATS JBI, RE	 6 ▶ 10 ▶
10 - 150 (63 - 1589)	50 - 250	Aluminium Cylinders, Single-Acting, Lock Nut, Hollow Plunger	  RAC RACL RACH	 12 ▶ 14 ▶ 16 ▶
20 - 150 (229 - 1589)	50 - 250	Aluminium Cylinders, Double-Acting Hollow Plunger & Solid Plunger	  RARH RAR	 18 ▶ 20 ▶
10 - 1000 (97 - 10.165)	6 - 17	Ultra-Flat Cylinders, Single-Acting, Load Return, with Stop Ring or Tilting Function	 CULP CUSP	 22 ▶ 23 ▶
60 - 500 (606 - 5114)	45 - 50	Low-Height Lock Nut Cylinders Single-Acting, Load Return	 LPL	 24 ▶
5 - 150 (45 - 1386)	6 - 62	Low-Height Cylinders, Single-Acting or spring-return	  RSM RCS	 26 ▶
4 - 74 (43 - 727)	17 - 600	Low-Height Telescopic Cylinders Multi-Stage Telescopic Cylinders	 RLT RT	 28 ▶ 30 ▶
2,5 - 50 (24 - 506)	127 - 154	Pull Cylinders, Single-Acting, Spring Return	 BRC BRP	 32 ▶
12 - 145 (125 - 1429)	8 - 258	Hollow Plunger Cylinders, Single- and Double-Acting	  RCH RRH	 34 ▶ 36 ▶
4 - 23 (35 - 222)	28 - 260	Precision Production Cylinders, Double-Acting (including Mounting Attachments)	 BRD	 38 ▶
10 - 520 (101 - 5108)	16 - 1219	Long Stroke Cylinders, Double-Acting	 RR	 40 ▶
50 - 1000 (550 - 10.644)	50 - 300	High Tonnage Cylinders, Single- and Double-Acting	  HCG HCR	 48 ▶ 52 ▶
50 - 1000 (550 - 10.644)	50 - 300	High Tonnage Lock Nut Cylinders, Single- and Double-Acting	  HCL HCRL	 56 ▶ 60 ▶
1 - 95 (8,9 - 933)	11 - 362	Cylinder - Pump Sets, Single-Acting Extreme Environment Products Power Box – Portable Tool Sets	 SC RC, P, V SL, SR, SW	 62 ▶ 64 ▶ 65 ▶
2 - 100 (20 - 980)	62 - 460	Aluminium and Steel Jacks Industrial Steel Bottle Jacks	 JH, JHA GBJ	 66 ▶ 67 ▶
54 - 181 (533 - 1778)	356 - 686	POW'R-RISER® Mobile Lifting Jacks POW'R-LOCK™ Mobile Lift System	  PR PL	 68 ▶ 70 ▶

¹⁾ All ton values specified in this catalogue are approximate and for cylinder class identification only. Please refer to the kN data for calculations.

▼ From left to right: RC2510, RC53, RC1002, RC108, RC5010, RC156



- Trio Bearing system with hardened composite wear bands for optimal side load resistance
- Strengthened Trio Stop Ring improves durability and side load resistance
- Trio Hybrid pre-tensioned spring system provides faster retraction
- High-grade polyethylene seals for low wear and long service life
- Plunger wiper reduces contamination, extending cylinder life.
- Collar and plunger threads and base mounting holes enable easy fixturing (on most models)
- Standard certified lifting eyes on cylinder models above 25 kg weight. Interchangeable with optional CHM6 carrying handle
- Designed for use in all positions
- Baked enamel finish for increased corrosion resistance
- Includes CR400 coupler, dust cap and collar thread protector
- RC-Series model numbers, external dimensions and threads remain unchanged from prior RC-Series cylinders

▼ *Foundation repair: to re-stabilize the foundation, the 308 ton silo needed to be lifted, levelled and structurally supported. 25 ton RC-Series hydraulic jacks were attached to a bracket on the top of each steel pier. Powered by a Z-Class pump, the hydraulic jacks applied 20 ton of force at each placement to lift the silo 5,1 cm.*



The Industry Standard General Purpose Cylinder



Saddles

All RC cylinders (except RC50 and RC101) have a hardened removable grooved saddle. For tilt and flat saddles, see the RC-Series accessory page. All CATS-Series Tilt Saddles use a nitrocarburization surface treatment for improved corrosion protection.

Page: 10



Base Plates

To ensure the stability of cylinders for lifting applications, base plates are available for 10, 25 and 50 ton RC cylinders.

Page: 10



Specialty Attachments

For solving all kinds of application problems, specialty attachments are available for 5, 10 and 25 ton RC cylinders.

Page: 182

▼ *Synchronous lifting set-up for 200 ton petrochemical process module using twelve RC2510 cylinders. To ensure the stability of the cylinders JBI25 base plates are installed.*



Single-Acting, General Purpose Cylinders



Optional Carrying Handle CHM6

Standard certified lifting eyes on cylinder models above 25 kg weight (RC5010 and heavier models). Interchangeable with optional carrying handle. Order model number **CHM6**.

▼ **QUICK SELECTION CHART** For complete technical information see next page.

Cylinder Capacity	Stroke	Model Number	Cylinder Effective Area	Oil Capacity	Collapsed Height	
ton (kN)	(mm)		(cm ²)	(cm ³)	(mm)	(kg)
5 (45)	16	RC50	6,4	10	41	1,0
	25	RC51	6,4	16	110	1,0
	79	RC53	6,4	50	165	1,5
	127	RC55 *	6,4	83	216	1,9
	177	RC57	6,4	115	273	2,4
	232	RC59	6,4	151	324	2,8
10 (101)	26	RC101	14,4	38	90	1,8
	54	RC102 *	14,4	78	121	2,3
	105	RC104	14,4	152	171	3,3
	156	RC106 *	14,4	226	248	4,4
	203	RC108	14,4	294	298	5,4
	257	RC1010 *	14,4	373	349	6,4
	304	RC1012	14,4	441	400	6,8
	356	RC1014	14,4	516	451	8,2
15 (142)	25	RC151	20,3	51	124	3,3
	51	RC152	20,3	104	149	4,1
	101	RC154 *	20,3	205	200	5,0
	152	RC156 *	20,3	308	271	6,8
	203	RC158	20,3	411	322	8,2
	254	RC1510	20,3	516	373	9,5
	305	RC1512	20,3	619	424	10,9
	356	RC1514	20,3	723	475	11,8
25 (232)	26	RC251	33,3	86	140	5,9
	50	RC252 *	33,3	166	165	6,4
	102	RC254 *	33,3	339	216	8,2
	158	RC256 *	33,3	525	273	10,0
	210	RC258	33,3	697	324	12,2
	261	RC2510	33,3	867	375	14,1
	311	RC2512	33,3	1033	425	16,3
	362	RC2514 *	33,3	1202	476	17,7
30 (295)	209	RC308	42,9	880	387	18,1
50 (498)	51	RC502	71,3	362	176	15,0
	101	RC504	71,3	719	227	19,1
	159	RC506 *	71,3	1131	283	23,1
	260	RC5010	71,3	1855	384	31,8
	337	RC5013	71,3	2399	460	37,6
75 (718)	156	RC756	102,6	1601	286	29,5
	333	RC7513	102,6	3417	492	59,0
95 (933)	50	RC1002	133,1	676	219	36,7
	168	RC1006	133,1	2239	357	59,0
	260	RC10010	133,1	3466	449	72,6

* Available as set, see note on this page.

RC-Trio Series



Capacity:
5 - 95 ton

Stroke:
16 - 362 mm

Maximum Operating Pressure:
700 bar



Think Safety

Manufacturer's rating of load and stroke are maximum safe limits. Good practice encourages using only 80% of these ratings.

Page: **406**



Lightweight Aluminium Cylinders

If you need a higher cylinder capacity-to-weight-ratio the **RAC-Series** are the perfect choice.

Page: **13**



Gauges

Minimize the risk of overloading and ensure long, dependable service from your equipment. Refer to the System Components

Section for a full range of gauges.

Page: **127**

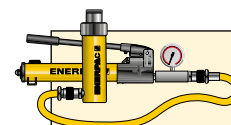

Cylinder-Pump Sets

All cylinders marked with an * are available as **sets** (cylinder, gauge, couplers, hose and pump) for your ordering convenience.

Page: **62**

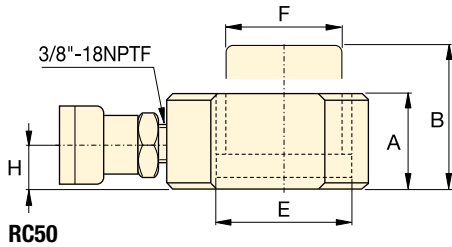
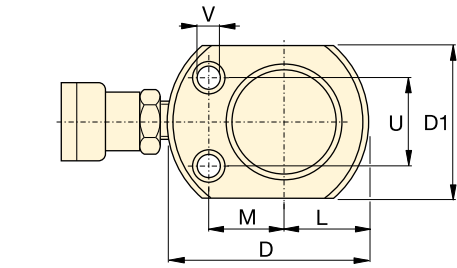

RC50

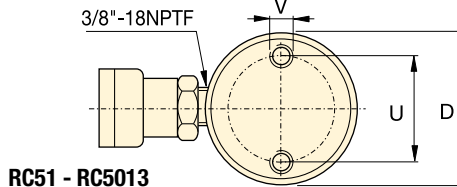
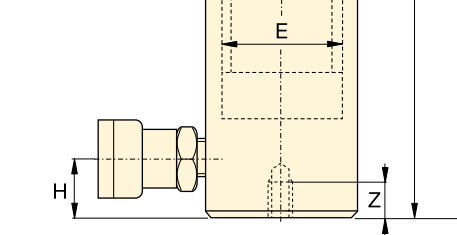
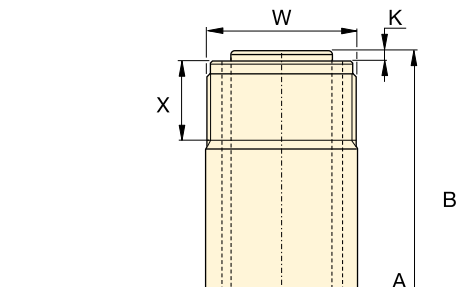
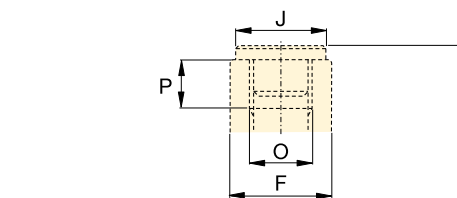
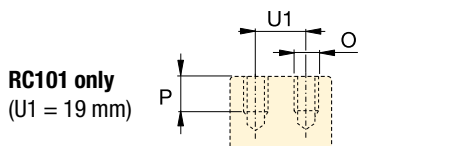

RC51 - RC5013

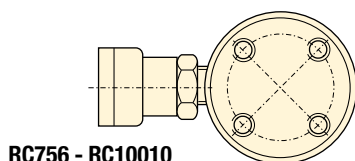

RC756 - RC10010



Speed Chart and Pump Selection Tool

See the Enerpac Cylinder Speed Chart in our 'Yellow Pages' to determine your approximate cylinder speed. See Pump Selection Tool on website for help to choose the most suitable pump for your application.

Page: **415**

◀ For full features see previous page.

Cylinder Capacity	Stroke	Model Number	Cylinder Effective Area	Oil Capacity	Collapsed Height	Extended Height	Outside Dia.
ton (kN)	(mm)		(cm ²)	(cm ³)	A (mm)	B (mm)	D (mm)
5 (45)	16	RC50 ²⁾	6,4	10	41	57	58 ³⁾
	25	RC51	6,4	16	110	135	38
	79	RC53	6,4	50	165	244	38
	127	RC55 ¹⁾	6,4	83	216	343	38
	177	RC57	6,4	115	273	450	38
	232	RC59	6,4	151	324	556	38
10 (101)	26	RC101 ⁴⁾	14,4	38	90	116	57
	54	RC102 ¹⁾	14,4	78	121	175	57
	105	RC104	14,4	152	171	276	57
	156	RC106 ¹⁾	14,4	226	248	404	57
	203	RC108	14,4	294	298	501	57
	257	RC1010 ¹⁾	14,4	373	349	606	57
	304	RC1012	14,4	441	400	704	57
	356	RC1014	14,4	516	451	807	57
15 (142)	25	RC151	20,3	51	124	149	70
	51	RC152	20,3	104	149	200	70
	101	RC154 ¹⁾	20,3	205	200	301	70
	152	RC156 ¹⁾	20,3	308	271	423	70
	203	RC158	20,3	411	322	525	70
	254	RC1510	20,3	516	373	627	70
	305	RC1512	20,3	619	424	729	70
	356	RC1514	20,3	723	475	831	70
25 (232)	26	RC251	33,3	86	140	166	86
	50	RC252 ¹⁾	33,3	166	165	215	86
	102	RC254 ¹⁾	33,3	339	216	318	86
	158	RC256 ¹⁾	33,3	525	273	431	86
	210	RC258	33,3	697	324	534	86
	261	RC2510	33,3	867	375	636	86
	311	RC2512	33,3	1033	425	736	86
	362	RC2514 ¹⁾	33,3	1202	476	838	86
30 (295)	209	RC308	42,9	880	387	596	102
50 (498)	51	RC502	71,3	362	176	227	127
	101	RC504	71,3	719	227	328	127
	159	RC506 ¹⁾	71,3	1131	283	442	127
	260	RC5010	71,3	1855	384	644	127
	337	RC5013	71,3	2399	460	797	127
75 (718)	156	RC756	102,6	1601	286	442	146
	333	RC7513	102,6	3417	492	825	146
95 (933)	51	RC1002	133,1	676	219	270	178
	168	RC1006	133,1	2239	357	525	178
	260	RC10010	133,1	3466	449	709	178

¹⁾ Available as set, see note on page 7.

²⁾ RC50 cylinder has a non removable grooved saddle and no collar thread.

³⁾ RC50: D1 = 41 mm, L = 20 mm, M = 25 mm.

⁴⁾ RC101 has plunger with two thread holes and non-removable saddle.

Single-Acting, General Purpose Cylinders

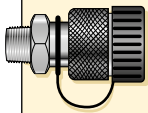

Couplers Included!

CR-400 couplers included on all models. Fits all HC-Series hoses.

Capacity:

5 - 95 ton

Stroke:

16 - 362 mm

Maximum Operating Pressure:

700 bar

RC-Trio Series



Cylinder Bore Dia. E (mm)	Plunger Dia. F (mm)	Base to Adv. Port H (mm)	Saddle Dia. J (mm)	Saddle Protr. from Plgr. K (mm)	Plunger Internal Thread O	Plunger Thread Length P (mm)	Base Mounting Holes			Collar Thread W	Collar Thread Length X (mm)	 (kg)	Model Number
							Bolt Circle U (mm)	Thread V	Thd. Depth Z (mm)				
28,6	25,4	19	2)	2)	2)	2)	29	5,6 mm	—	—	—	1,0	RC50 ²⁾
28,6	25,4	19	25	6	3/4" - 16 UN	14	25	1/4" - 20 UNC	14	1 1/2" - 16 UN	28	1,0	RC51
28,6	25,4	19	25	6	3/4" - 16 UN	14	25	1/4" - 20 UNC	14	1 1/2" - 16 UN	28	1,5	RC53
28,6	25,4	19	25	6	3/4" - 16 UN	14	25	1/4" - 20 UNC	14	1 1/2" - 16 UN	28	1,9	RC55 ¹⁾
28,6	25,4	19	25	6	3/4" - 16 UN	16	25	1/4" - 20 UNC	14	1 1/2" - 16 UN	28	2,4	RC57
28,6	25,4	19	25	6	3/4" - 16 UN	16	25	1/4" - 20 UNC	14	1 1/2" - 16 UN	28	2,8	RC59
42,8	38,1	19	—	—	#10 - 24 UN	6	40	5/16" - 18 UNC	12	2 1/4" - 14 UN	27	1,8	RC101 ⁴⁾
42,8	38,1	19	35	6	1" - 8 UN	19	40	5/16" - 18 UNC	12	2 1/4" - 14 UN	27	2,3	RC102 ¹⁾
42,8	38,1	19	35	6	1" - 8 UN	19	40	5/16" - 18 UNC	12	2 1/4" - 14 UN	27	3,3	RC104
42,8	38,1	19	35	6	1" - 8 UN	19	40	5/16" - 18 UNC	12	2 1/4" - 14 UN	27	4,4	RC106 ¹⁾
42,8	38,1	19	35	6	1" - 8 UN	19	40	5/16" - 18 UNC	12	2 1/4" - 14 UN	27	5,4	RC108
42,8	38,1	19	35	6	1" - 8 UN	19	40	5/16" - 18 UNC	12	2 1/4" - 14 UN	27	6,4	RC1010 ¹⁾
42,8	38,1	19	35	6	1" - 8 UN	19	40	5/16" - 18 UNC	12	2 1/4" - 14 UN	27	6,8	RC1012
42,8	38,1	19	35	6	1" - 8 UN	19	40	5/16" - 18 UNC	12	2 1/4" - 14 UN	27	8,2	RC1014
50,8	41,3	19	38	9	1" - 8 UN	25	48	3/8" - 16 UNC	12	2 3/4" - 16 UN	30	3,3	RC151
50,8	41,3	19	38	9	1" - 8 UN	25	48	3/8" - 16 UNC	12	2 3/4" - 16 UN	30	4,1	RC152
50,8	41,3	19	38	9	1" - 8 UN	25	48	3/8" - 16 UNC	12	2 3/4" - 16 UN	30	5,0	RC154 ¹⁾
50,8	41,3	25	38	9	1" - 8 UN	25	48	3/8" - 16 UNC	12	2 3/4" - 16 UN	30	6,8	RC156 ¹⁾
50,8	41,3	25	38	9	1" - 8 UN	25	48	3/8" - 16 UNC	12	2 3/4" - 16 UN	30	8,2	RC158
50,8	41,3	25	38	9	1" - 8 UN	25	48	3/8" - 16 UNC	12	2 3/4" - 16 UN	30	9,5	RC1510
50,8	41,3	25	38	9	1" - 8 UN	25	48	3/8" - 16 UNC	12	2 3/4" - 16 UN	30	10,9	RC1512
50,8	41,3	25	38	9	1" - 8 UN	25	48	3/8" - 16 UNC	12	2 3/4" - 16 UN	30	11,8	RC1514
65,1	57,2	25	51	10	1 1/2" - 16 UN	25	59	1/2" - 13 UNC	19	3 5/16" - 12 UN	49	5,9	RC251
65,1	57,2	25	51	10	1 1/2" - 16 UN	25	59	1/2" - 13 UNC	19	3 5/16" - 12 UN	49	6,4	RC252 ¹⁾
65,1	57,2	25	51	10	1 1/2" - 16 UN	25	59	1/2" - 13 UNC	19	3 5/16" - 12 UN	49	8,2	RC254 ¹⁾
65,1	57,2	25	51	10	1 1/2" - 16 UN	25	59	1/2" - 13 UNC	19	3 5/16" - 12 UN	49	10,0	RC256 ¹⁾
65,1	57,2	25	51	10	1 1/2" - 16 UN	25	59	1/2" - 13 UNC	19	3 5/16" - 12 UN	49	12,2	RC258
65,1	57,2	25	51	10	1 1/2" - 16 UN	25	59	1/2" - 13 UNC	19	3 5/16" - 12 UN	49	14,1	RC2510
65,1	57,2	25	51	10	1 1/2" - 16 UN	25	59	1/2" - 13 UNC	19	3 5/16" - 12 UN	49	16,3	RC2512
65,1	57,2	25	51	10	1 1/2" - 16 UN	25	59	1/2" - 13 UNC	19	3 5/16" - 12 UN	49	17,7	RC2514 ¹⁾
73,0	57,2	29	51	10	1 1/2" - 16 UN	25	59	1/2" - 13 UNC	16	3 5/16" - 12 UN	49	18,1	RC308
95,2	79,4	33	71	2	—	—	95	1/2" - 13 UNC	19	5" - 12 UN	55	15,0	RC502
95,2	79,4	33	71	2	—	—	95	1/2" - 13 UNC	19	5" - 12 UN	55	19,1	RC504
95,2	79,4	35	71	2	—	—	95	1/2" - 13 UNC	19	5" - 12 UN	55	23,1	RC506 ¹⁾
95,2	79,4	35	71	2	—	—	95	1/2" - 13 UNC	19	5" - 12 UN	55	31,8	RC5010
95,2	79,4	35	71	2	—	—	95	1/2" - 13 UNC	19	5" - 12 UN	55	37,6	RC5013
114,3	95,3	30	71	2	—	—	114	5/8" - 13 UNC	16	5 3/4" - 12 UN	44	29,5	RC756
114,3	95,3	30	71	2	—	—	114	5/8" - 13 UNC	16	5 3/4" - 12 UN	44	59,0	RC7513
130,2	104,8	41	71	2	—	—	140	3/4" - 10 UNC	25	6 7/8" - 12 UN	44	36,7	RC1002
130,2	104,8	41	71	2	—	—	140	3/4" - 10 UNC	25	6 7/8" - 12 UN	44	59,0	RC1006
130,2	104,8	41	71	2	—	—	140	3/4" - 10 UNC	25	6 7/8" - 12 UN	44	72,6	RC10010

SELECTION CHART

For use with Cylinder Capacity ton (kN)	Saddles			Base Plate	Mounting Block	Clevis Eyes	
	Flat	Grooved ¹⁾	Tilt			Base ⁴⁾	Plunger
5 (45)	A53F ²⁾	A53G ²⁾	-	-	RB5 ²⁾ , AW51 ²⁾ , AW53 ²⁾	REB5 ²⁾	REP5 ²⁾
10 (101)	A12 ³⁾ , A102F ³⁾	A102G ³⁾	CATS12 ³⁾	JB110 ³⁾	RB10, AW102	REB10	REP10 ³⁾
15 (142)	-	A152G	CATS12	-	RB15	REB15	REP10
25 (232)	A29 ⁵⁾	A252G	CATS52	JB125	RB25	REB25	REP25
30 (295)	A29 ⁵⁾	A252G	CATS52	-	RB25	-	REP25
50 (498)	-	-	CATS100	JB150	-	-	-
75 (718)	-	-	CATS100	-	-	-	-
95 (933)	-	-	CATS100	-	-	-	-

¹⁾ Standard on 5-30 ton RC-cylinders ²⁾ Except RC50 ³⁾ Except RC101 ⁴⁾ Mounting screws are included. ⁵⁾ Used with Bender Sets.

DIMENSION CHARTS

Model Number	Saddle Dimensions (mm)			A53F, A102F A12, A29	For Cylinder Capacity ton (kN)	Tilt Saddle Model Number	Addition to Collapsed Height A1 (mm)	Saddle Diameter J1 (mm)	
	A	B	C						
Flat					10 (101)	CATS12	14	35	
A53F	25	6	17	15 (142)	CATS12	11	35		
A102F	35	6	22	25 (232)	CATS52	15	50		
A12	51	48	1"-8 UNC	30 (295)	CATS52	15	50		
Grooved					50 (498)	CATS100	15	71	
A53G	25	6	17	75 (718)	CATS100	15	71		
A102G	35	6	22	95 (933)	CATS100	15	71		
A152G	38	9	22						
A252G	50	9	35						

Model Number	Base Plate Dimensions (mm)						
	A	B	C	D	E		
JB110	228	228	135	58	20		
JB125	279	279	140	86	26		
JB150	304	15	95	131	31		

Model Number	Mounting Block Dimensions (mm)											
	A	B	C	D	E	F	G	H				
RB5	1 1/2" -16UN	88	76	-	25	-	-	-				
AW51	1 1/2" -16UN	70	59	10	24	54	1/4" -16 UN	41				
AW53	1 1/2" -16UN	72	7	7	19	57	1/4" -20 UN	10				
RB10	2 1/4" -14UN	114	88	-	25	-	-	-				
AW102	2 1/4" -14UN	100	82	16	30	76	7/16" -20 UN	58				
RB15	2 3/4" -16UN	101	114	-	38	-	-	-				
RB25	3 5/16" -12UN	127	165	-	50	-	-	-				

Type	Model Number	Clevis Eye Dimensions (mm)						Pin-to-Pin * (mm)		
		A	B	C	D	E	F			
Base ⁴⁾	REB5	44	47	14	16	16	25	60,2		
	REB10	63	66	25	22	25	35	78,0		
	REB15	76	66	25	22	25	35	78,0		
	REB25	95	79	38	31	31	41	87,6		
Plunger	REP5	28	45	14	16	16	19	-		
	REP10	42	61	25	22	25	28	-		
	REP25	57	71	38	31	31	35	-		

⁴⁾ Mounting screws are included.

* Pin to Pin – REB and REP Clevises fitted. Add cylinder collapsed height.

The Enerpac Lightweight Aluminium Cylinders

▼ From left to right: RAC, RACL, RACH, RAR



- **Lightweight, easy to carry and position to allow a higher cylinder capacity-to-weight-ratio**
- **Non-corrosive by design, aluminium has always been a good material for use in many caustic environments**
- **Composite Bearings on all moving surfaces guarantee no metal-to-metal contact, to resist side loads and increase cylinder life.**

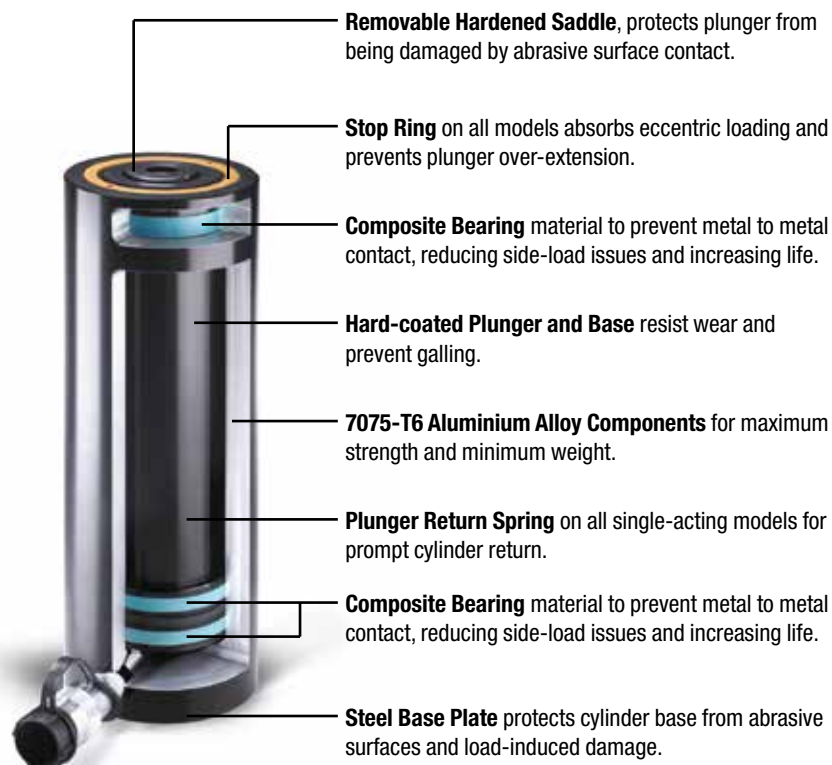

RA Series

Capacity:
10 - 150 ton

Stroke:
50 - 250 mm

Maximum Operating Pressure:
700 bar



Think Safety

Manufacturer's rating of load and stroke are maximum safe limits.

Good practice encourages using only 80% of these ratings.

Page: 406



Aluminium versus Steel

Aluminium cylinders, while offering the most lightweight solution, also have some unique limitations due to material properties. It differs from steel in that it has a lower finite fatigue life. Aluminium cylinders should NOT be used in high-cycle applications such as production.

The Enerpac line of aluminium cylinders are designed to provide 5000 cycles at their recommended pressure. **This limit should not be exceeded.** In normal lifting and many maintenance applications, this should provide a lifetime of use.



Steel Base Plate

The steel base plate protects the cylinder from damage, it should not be removed.

The base holes in these aluminium cylinders are designed for securing the steel base plate. They will not withstand the capacity of the cylinder.

Do not use the base holes in these aluminium cylinders to attach any device to the cylinder.

▼ Shown from left to right: RAC5010, RAC15010, RAC304, RAC208



Lightweight for Maximum Portability



Saddles

All RAC-cylinders are equipped with bolt-on removable hardened steel saddles. For Tilt Saddles see next page.

Page: 13



Lightweight Hand Pumps

The Enerpac composite lightweight hand pumps P392 or P802 make the optimal lightweight set.

Page: 76

- Composite bearings prevent metal-to-metal contact, increasing cylinder life and resistance to side-loads of up to 10%
- Hard-Coat finish on all surfaces resists damage and extends cylinder life
- Handles included on all 30 - 150 ton models
- For protection against load-induced damage a saddle is standard on all models
- Steel base plate is standard on RAC 20 ton models and above. The steel base plate is optional only on RAC10 and 15 ton models
- Integral stop ring prevents plunger over-travel and is capable of withstanding the full cylinder capacity
- High strength return spring for rapid cylinder retraction
- CR400 coupler and dustcap included on all models
- All cylinders meet ASME B-30.1 standard.

Cylinder Capacity at 700 bar ton (kN)	Stroke (mm)	Model Number	Cylinder Effective Area (cm ²)
10 (88)	50	RAC102	12,6
	100	RAC104	12,6
	150	RAC106	12,6
15 (137)	50	RAC152	19,6
	100	RAC154	19,6
	150	RAC156	19,6
20 (218)	50	RAC202	31,2
	100	RAC204	31,2
	150	RAC206	31,2
	200	RAC208	31,2
	250	RAC2010	31,2
30 (309)	50	RAC302	44,2
	100	RAC304	44,2
	150	RAC306	44,2
	200	RAC308	44,2
	250	RAC3010	44,2
50 (496)	50	RAC502	70,9
	100	RAC504	70,9
	150	RAC506	70,9
	200	RAC508	70,9
	250	RAC5010	70,9
100 (1002)	50	RAC1002	143,1
	100	RAC1004	143,1
	150	RAC1006	143,1
	200	RAC1008	143,1
	250	RAC10010	143,1
150 (1589)	50	RAC1502	227,0
	100	RAC1504	227,0
	150	RAC1506	227,0
	200	RAC1508	227,0
	250	RAC15010	227,0



◀ The unique Enerpac RA-Series cylinders – lightweight and made of aluminium alloy – these RAC506 cylinders are ideal for the positioning of tunnel elements under the river (High Speed Train Line, The Netherlands).

Single-Acting, Aluminium Cylinders

Optional Bolt-on Tilt Saddle Dimensions (mm)			
For Cylinder Model / Capacity ton	Tilt Saddle * Model Number	Tilt Saddle Diameter	Addition to Collapsed Height A1
RAC20, 30	CATS30	55	11
RAC50	CATS50	71	14
RAC100	CATS150	97	19
RAC150	CATS200	126	18

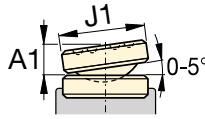

* Tilt saddles not available for 10 and 15 ton models

Optional Steel Base Plate	
For Cylinder Model / Capacity ton	Base Plate ²⁾ Model Number
RAC10	JBA10
RAC15	JBA15

²⁾ Base plate height of 6mm included on all 20-150 ton models. Base Plate is optional on 10-15 ton cylinders.

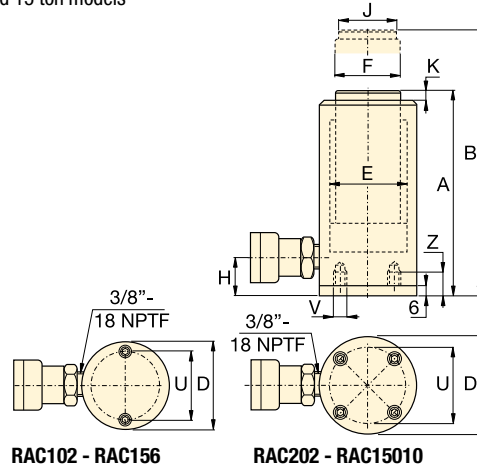

RAC Series



Capacity:

10 - 150 ton

Stroke:

50 - 250 mm

Maximum Operating Pressure:

700 bar



Steel Base Plate

The steel base plate protects the cylinder from damage, it should not be removed. See warning on page 11.

Oil Capacity (cm ³)	Collapsed Height A (mm)	Extended Height B (mm)	Outside Diameter D (mm)	Cylinder Bore Diameter E (mm)	Plunger Diameter F (mm)	Bottom to Advance Port H (mm)	Saddle Diameter J (mm)	Saddle Protrusion from Plunger K (mm)	Bolt Circle U (mm)	Thread V (mm)	Thread Depth Z (mm)	Weight (kg)	Model Number
60	154	201	58	40	32	23	24	3	39	M6	12	1,3	RAC102
130	204	304	58	40	32	23	24	3	39	M6	12	1,7	RAC104
190	254	404	58	40	32	23	24	3	39	M6	12	2,0	RAC106
100	161	211	70	50	40	23	29	3	48	M6	12	1,9	RAC152
200	211	311	70	50	40	23	29	3	48	M6	12	2,4	RAC154
290	261	411	70	50	40	23	29	3	48	M6	12	2,9	RAC156
156	174	224	85	63	50	27	40	3	70	M6	12	3,6	RAC202
312	224	324	85	63	50	27	40	3	70	M6	12	4,1	RAC204
468	274	424	85	63	50	27	40	3	70	M6	12	4,6	RAC206
624	324	524	85	63	50	27	40	3	70	M6	12	5,1	RAC208
780	374	624	85	63	50	27	40	3	70	M6	12	5,6	RAC2010
221	181	231	100	75	60	32	40	3	80	M6	12	4,5	RAC302
442	231	331	100	75	60	32	40	3	80	M6	12	5,2	RAC304
663	281	431	100	75	60	32	40	3	80	M6	12	5,9	RAC306
884	331	531	100	75	60	32	40	3	80	M6	12	6,6	RAC308
1105	381	631	100	75	60	32	40	3	80	M6	12	7,3	RAC3010
354	186	236	130	95	80	30	50	3	110	M6	12	8,5	RAC502
709	236	336	130	95	80	30	50	3	110	M6	12	9,8	RAC504
1063	286	436	130	95	80	30	50	3	110	M6	12	11,1	RAC506
1417	336	536	130	95	80	30	50	3	110	M6	12	12,4	RAC508
1771	386	636	130	95	80	30	50	3	110	M6	12	13,7	RAC5010
715	221	271	180	135	110	46	94	3	150	M10	12	17,3	RAC1002
1431	271	371	180	135	110	46	94	3	150	M10	12	19,6	RAC1004
2147	321	471	180	135	110	46	94	3	150	M10	12	21,9	RAC1006
2863	371	571	180	135	110	46	94	3	150	M10	12	24,2	RAC1008
3578	421	671	180	135	110	46	94	3	150	M10	12	26,5	RAC10010
1135	243	293	230	170	140	51	113	3	200	M10	12	25,3	RAC1502
2270	293	393	230	170	140	51	113	3	200	M10	12	29,3	RAC1504
3405	343	493	230	170	140	51	113	3	200	M10	12	33,3	RAC1506
4540	393	593	230	170	140	51	113	3	200	M10	12	37,3	RAC1508
5675	443	693	230	170	140	51	113	3	200	M10	12	41,3	RAC15010

▼ Shown from left to right: RACL1006, RACL504, RACL5010



- Aluminium Lock Nut provides mechanical load holding for extended periods
- Hardened steel stop ring increasing cylinder life and resistance to side-loads of up to 5%
- Hard-Coat finish on all surfaces resists damage and extends cylinder life
- Composite bearings increase cylinder life and side load resistance
- Handles included on all models
- Steel base plate and saddle for protection against load-induced damage
- Integral stop ring prevents plunger over-travel and is capable of withstanding the full cylinder capacity
- High strength return spring for rapid cylinder retraction
- CR400 coupler and dustcap included on all models
- All cylinders meet ASME B-30.1 standards.



◀ The portable lock nut cylinder RACL1506 used for extended load supports during epoxy injection for bridge reinforcement.



Saddles

All RACL-cylinders are equipped with bolt-on removable hardened steel saddles. For Tilt Saddles see next page.

Page: 15



Hoses

Enerpac offers a complete line of high quality hydraulic hoses. To ensure the integrity of your system, specify only Enerpac hydraulic hoses.

Page: 128

Cylinder Capacity @ 700 bar ton (kN)	Stroke (mm)	Model Number	Cylinder Effective Area (cm ²)
20 (218)	50	RACL202	31,2
	100	RACL204	31,2
	150	RACL206	31,2
	200	RACL208	31,2
	250	RACL2010	31,2
30 (309)	50	RACL302	44,2
	100	RACL304	44,2
	150	RACL306	44,2
	200	RACL308	44,2
	250	RACL3010	44,2
50 (496)	50	RACL502	70,9
	100	RACL504	70,9
	150	RACL506	70,9
	200	RACL508	70,9
	250	RACL5010	70,9
100 (1002)	50	RACL1002	143,1
	100	RACL1004	143,1
	150	RACL1006	143,1
	200	RACL1008	143,1
	250	RACL10010	143,1
150 (1589)	50	RACL1502	227,0
	100	RACL1504	227,0
	150	RACL1506	227,0
	200	RACL1508	227,0
	250	RACL15010	227,0

Single-Acting, Aluminium Lock Nut Cylinders

Optional Bolt-on Tilt Saddle Dimensions (mm)			
For Cylinder Model / Capacity ton	Tilt Saddle Model Number	Tilt Saddle Diameter	Addition to Collapsed Height A1
		J1	A1
RACL20, 30	CATS30	55	11
RACL50	CATS50	71	14
RACL100	CATS150	97	19
RACL150	CATS200	126	18

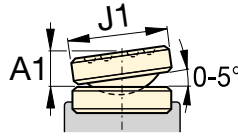

Steel Base Plate Mounting Holes			
Cylinder Model / Capacity ton	Bolt Circle U (mm)	Thread V (mm)	Thread Depth ¹⁾ Z (mm)
RACL20	70	M6	12
RACL30	80	M6	12
RACL50	110	M6	12
RACL100	150	M10	12
RACL150	200	M10	12

¹⁾ Including Base Plate Height of 6 mm and four (4) base plate bolts M6.

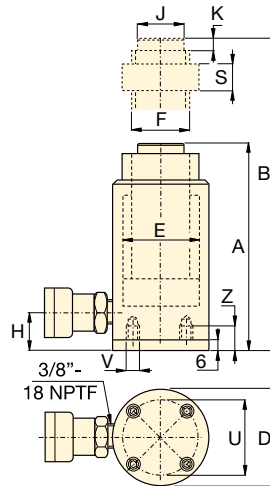

RACL Series



Capacity:

20 - 150 ton

Stroke:

50 - 250 mm

Maximum Operating Pressure:

700 bar

Oil Capacity (cm ³)	Collapsed Height A (mm)	Extended Height B (mm)	Outside Diameter D (mm)	Cylinder Bore Diameter E (mm)	Plunger Diameter (Threaded) F (mm)	Bottom to Advance Port H (mm)	Saddle Diameter J (mm)	Saddle Protrusion from Plunger K (mm)	Lock Nut Height S (mm)	Weight (kg)	Model Number
156	224	274	85	63	Tr 55 x 4	27	40	3	50	4,0	RACL202
312	274	374	85	63	Tr 55 x 4	27	40	3	50	4,6	RACL204
468	324	474	85	63	Tr 55 x 4	27	40	3	50	5,2	RACL206
624	374	574	85	63	Tr 55 x 4	27	40	3	50	5,8	RACL208
780	424	674	85	63	Tr 55 x 4	27	40	3	50	6,4	RACL2010
221	231	281	100	75	Tr 60 x 4	33	40	3	50	5,4	RACL302
442	281	381	100	75	Tr 60 x 4	33	40	3	50	6,1	RACL304
663	331	481	100	75	Tr 60 x 4	33	40	3	50	6,8	RACL306
883	381	581	100	75	Tr 60 x 4	33	40	3	50	7,5	RACL308
1105	431	681	100	75	Tr 60 x 4	33	40	3	50	8,2	RACL3010
354	236	286	130	95	Tr 80 x 4	30	50	3	50	9,3	RACL502
709	286	386	130	95	Tr 80 x 4	30	50	3	50	10,6	RACL504
1063	336	486	130	95	Tr 80 x 4	30	50	3	50	12,6	RACL506
1417	386	586	130	95	Tr 80 x 4	30	50	3	50	13,2	RACL508
1771	436	686	130	95	Tr 80 x 4	30	50	3	50	14,5	RACL5010
716	296	346	180	135	Tr 110 x 6	46	94	3	75	21,9	RACL1002
1431	346	446	180	135	Tr 110 x 6	46	94	3	75	24,2	RACL1004
2147	396	546	180	135	Tr 110 x 6	46	94	3	75	26,5	RACL1006
2863	446	646	180	135	Tr 110 x 6	46	94	3	75	28,8	RACL1008
3578	496	746	180	135	Tr 110 x 6	46	94	3	75	31,1	RACL10010
1135	323	373	230	170	Tr 140 x 6	51	113	3	80	32,2	RACL1502
2270	373	473	230	170	Tr 140 x 6	51	113	3	80	36,2	RACL1504
3405	423	573	230	170	Tr 140 x 6	51	113	3	80	40,2	RACL1506
4540	473	673	230	170	Tr 140 x 6	51	113	3	80	44,2	RACL1508
5675	523	773	230	170	Tr 140 x 6	51	113	3	80	48,2	RACL15010

▼ Shown from left to right: RACH1504, RACH15010, RACH206, RACH306



The Lightweight Solution for Tensioning and Testing



Saddles

All RACH-cylinders are equipped with bolt-on hollow removable saddles of hardened steel.



Lightweight Hand Pumps

The Enerpac composite lightweight hand pumps P392 or P802 make the optimal lightweight set.

Page: 76

- Hollow plunger design allows for both pull and push forces
- Composite bearings increase cylinder life and sideload resistance
- Hard-Coat finish on all surfaces resists damage and extends cylinder life
- Floating center tube increases seal and product life
- Handles standard on all models
- Steel base plate and saddle for protection against load-induced damage
- Integral stop ring prevents plunger over-travel and is capable of withstanding the full cylinder capacity
- High strength return spring for rapid cylinder retraction
- CR400 coupler and dustcap included on all models
- All cylinders meet ASME B-30.1 standards.



◀ An RACH306 powered by a P392 hand pump used to extract corroded carriage pins of refuse collection vehicles.

Cylinder Capacity @ 700 bar ton (kN)	Stroke (mm)	Model Number	Cylinder Effective Area (cm ²)
20 (229)	50	RACH202	32,7
	100	RACH204	32,7
	150	RACH206	32,7
	200	RACH208	32,7
	250	RACH2010	32,7
30 (358)	50	RACH302	51,1
	100	RACH304	51,1
	150	RACH306	51,1
	200	RACH308	51,1
	250	RACH3010	51,1
60 (596)	50	RACH602	84,7
	100	RACH604	84,7
	150	RACH606	84,7
	200	RACH608	84,7
	250	RACH6010	84,7
100 (1157)	50	RACH1002	164,6
	100	RACH1004	164,6
	150	RACH1006	164,6
	200	RACH1008	164,6
	250	RACH10010	164,6
150 (1588)	50	RACH1502	225,8
	100	RACH1504	225,8
	150	RACH1506	225,8
	200	RACH1508	225,8
	250	RACH15010	225,8

Single-Acting, Aluminium Hollow Plunger Cylinders

Steel Base Plate Mounting Holes

Cylinder Model / Capacity ton	Bolt Circle U (mm)	Thread V (mm)	Thread Depth ¹⁾ Z (mm)
RACH20	80	M6	12
RACH30	110	M6	12
RACH60	160	M6	12
RACH100	220	M10	12
RACH150	245	M10	12

¹⁾ Including Base Plate Height of 6 mm and four (4) base plate bolts M6.

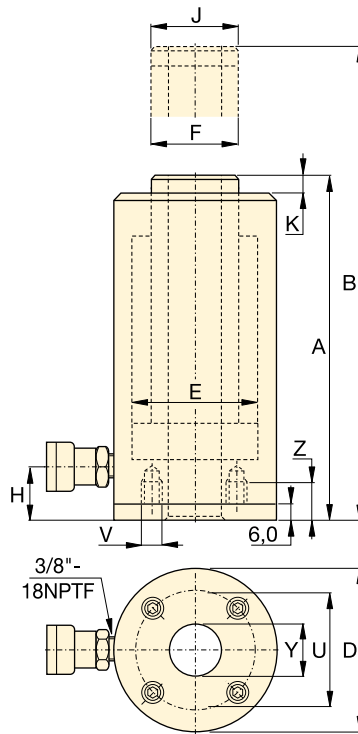

RACH Series

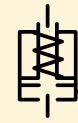

Capacity:

20 - 150 ton

Stroke:

50 - 250 mm

Center Hole Diameter:

27 - 79 mm

Maximum Operating Pressure:

700 bar

Oil Capacity (cm ³)	Collapsed Height A (mm)	Extended Height B (mm)	Outside Diameter D (mm)	Cylinder Bore Diameter E (mm)	Plunger Diameter F (mm)	Bottom to Advance Port H (mm)	Saddle Diameter J (mm)	Saddle Protrusion from Plunger K (mm)	Center Hole Diameter Y (mm)	Weight (kg)	Model Number
164	188	238	100	75	55	29	55	10	27	5,2	RACH202
327	251	351	100	75	55	29	55	10	27	6,1	RACH204
491	315	465	100	75	55	29	55	10	27	7,1	RACH206
654	378	578	100	75	55	29	55	10	27	8,0	RACH208
818	442	692	100	75	55	29	55	10	27	9,0	RACH2010
256	208	258	130	95	70	29	70	10	34	8,0	RACH302
511	267	367	130	95	70	29	70	10	34	9,5	RACH304
766	333	483	130	95	70	29	70	10	34	11,2	RACH306
1022	395	595	130	95	70	29	70	10	34	12,9	RACH308
1277	458	708	130	95	70	29	70	10	34	14,5	RACH3010
423	251	301	180	130	100	61	100	12	54	16,2	RACH602
847	315	415	180	130	100	61	100	12	54	19,5	RACH604
1270	380	530	180	130	100	61	100	12	54	25,6	RACH606
1694	445	645	180	130	100	61	100	12	54	26,0	RACH608
2117	510	760	180	130	100	61	100	12	54	29,6	RACH6010
823	258	308	250	185	145	61	145	14	79	33,8	RACH1002
1646	325	425	250	185	145	61	145	14	79	39,8	RACH1004
2487	391	541	250	185	145	61	145	14	79	46,2	RACH1006
3291	459	659	250	185	145	61	145	14	79	52,2	RACH1008
4114	527	777	250	185	145	61	145	14	79	58,8	RACH10010
1129	280	330	275	205	150	61	145	14	79	48,9	RACH1502
2258	360	460	275	205	150	61	145	14	79	55,7	RACH1504
3387	430	580	275	205	150	61	145	14	79	63,0	RACH1506
4517	500	700	275	205	150	61	145	14	79	70,1	RACH1508
5646	570	820	275	205	150	61	145	14	79	77,2	RACH15010

▼ Shown from left to right: RARH6010 and RARH306



- Lighter and shorter collapsed height than equivalent RACH models
- Double-acting for rapid retraction, regardless of hose lengths or system losses
- Built-in safety valve prevents accidental over-pressurization
- Hollow plunger design allows for both pull and push forces
- Hard coat finish on all surfaces resists damage and extends cylinder life
- Handles and CR400 couplers with dust caps included on all models
- Floating center tube increases seal life
- Steel baseplate and saddle for protection against load-induced damage
- Integral stop ring prevents plunger over-travel and is capable of withstanding the full cylinder capacity
- All cylinders meet ASME B-30.1 standards.

The Lightweight Solution for Double-Acting Applications



Hoses

Enerpac offers a complete line of high-quality hydraulic hoses. To ensure the integrity of your system, specify only Enerpac hydraulic hoses.

Page: 128



Gauges

Minimize the risk of overloading and ensure long, dependable service from your equipment. Refer to the System Components section for a full range of gauges.

Page: 127



4-Way Control Valve

The P84 and P464 hand pumps feature a manual 4-way control valve, designed for use with one double-acting or two single-acting cylinders. For system set-up information:

Page: 78

Cylinder Capacity ton (kN)	Stroke * (mm)	Model Number	Maximum Cylinder Capacity at 700 bar (kN)		Cylinder Effective Area (cm ²)		Oil Capacity (cm ³)	
			Advance	Retract	Advance	Retract	Advance	Retract
30 (359)	50	RARH302	359	187	51,2	26,7	256	134
	150	RARH306	359	187	51,2	26,7	769	401
	250	RARH3010	359	187	51,2	26,7	1281	668
60 (595)	50	RARH602	595	264	84,9	37,7	425	189
	150	RARH606	595	264	84,9	37,7	1274	566
	250	RARH6010	595	264	84,9	37,7	2124	943
100 (1001)	50	RARH1002	1001	568	142,9	81,1	715	405
	150	RARH1006	1001	568	142,9	81,1	2144	1216
	250	RARH10010	1001	568	142,9	81,1	3574	2027
150 (1489)	50	RARH1502	1489	748	212,6	106,8	1063	534
	150	RARH1506	1489	748	212,6	106,8	3190	1602
	250	RARH15010	1489	748	212,6	106,8	5316	2670

* Intermediate strokes and other tonnages available upon request.

Aluminium Double-Acting Hollow Plunger Cylinders



Steel Base Plate

The steel base plate protects the cylinder base from damage, it should not be removed. The base holes in these aluminum cylinders are designed for securing the steel base plate.

They will not withstand the capacity of the cylinder. Do not use the base holes in these aluminum cylinders to attach any device to the cylinder.

Optional Threaded Hollow Saddles

Saddle Type	Cylinder Model Number	Saddle Model Number	Saddle Dimensions (mm)		
			A	B	C
Threaded Hollow	RARH302, 306, 3010	HP3015	63	1 1/4" - 7 UN	9
	RARH602, 606, 6010	HP5016	91	1 5/8" - 5 1/2 UN	12
	RARH1002, 1006, 10010	HP10016	126	2 1/2" - 8 UN	13

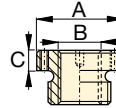

Smooth hollow saddles are standard on all RARH-models.

Steel Base Plate Mounting Holes (mm)

Cylinder Model / Capacity (ton)	Bolt Circle U	Thread V	Thread Depth ¹⁾ Z
RARH30	110	M6	12
RARH60	160	M6	12
RARH100	200	M10	12
RARH150	250	M10	12

¹⁾ Including Base Plate Height of 6 mm and four (4) base plate bolts.

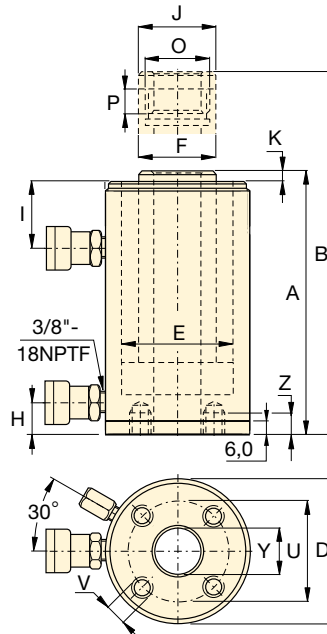

RARH Series



Capacity:

30 - 150 ton

Stroke:

50 - 250 mm

Center Hole Diameter:

34 - 79 mm

Maximum Operating Pressure:

700 bar



RACH-Series, Single-Acting, Spring Return

To be used when a single-acting pump is available and retraction time is not critical.

Page: 16



Pump Selection

A double-acting cylinder must be powered by a pump with a 4-way valve.

Page: 408

Collapsed Height	Extended Height	Outside Diameter	Cylinder Bore Diameter	Plunger Diameter	Cyl. Base to Advance Port	Cyl. Top to Return Port	Saddle Diameter	Saddle Protrusion from Plunger	Plunger Internal Thread	Plunger Thread Length	Center Hole Diameter	Weight (kg)	Model Number
A (mm)	B (mm)	D (mm)	E (mm)	F (mm)	H (mm)	I (mm)	J (mm)	K (mm)	O (inch)	P (mm)	Y (mm)	(kg)	
209	259	135	95	75	22	64	63	10	1 13/16"-16 UN	23	34	8,9	RARH302
309	459	135	95	75	22	64	63	10	1 13/16"-16 UN	23	34	11,9	RARH306
409	659	135	95	75	22	64	63	10	1 13/16"-16 UN	23	34	14,9	RARH3010
246	296	180	130	110	48	83	92	13	2 3/4"-16 UN	20	54	16,8	RARH602
346	496	180	130	110	48	83	92	13	2 3/4"-16 UN	20	54	22,2	RARH606
446	696	180	130	110	48	83	92	13	2 3/4"-16 UN	20	54	27,6	RARH6010
254	304	235	165	130	61	78	126	13,5	4"-16 UN	27	79	28,9	RARH1002
354	504	235	165	130	61	78	126	13,5	4"-16 UN	27	79	38,3	RARH1006
454	704	235	165	130	61	78	126	13,5	4"-16 UN	27	79	47,7	RARH10010
264	314	280	190	150	61	83	127	18,8	4 1/4"-12 UN	40	79	42,4	RARH1502
364	514	280	190	150	61	83	127	18,8	4 1/4"-12 UN	40	79	56,2	RARH1506
464	714	280	190	150	61	83	127	18,8	4 1/4"-12 UN	40	79	70,0	RARH15010

▼ Shown from left to right: RAR5010, RAR308, RAR204



Saddles

All RAR-cylinders are equipped with bolt-on removable hardened steel saddles. For Tilt Saddles see next page.

Page: 21



Hoses

Enerpac offers a complete line of high quality hydraulic hoses. To ensure the integrity of your system, specify only Enerpac hydraulic hoses.

Page: 128

- Double-acting for rapid retraction, regardless of hose lengths or system losses
- Composite bearings increase cylinder life and sideload resistance
- Hard-Coat finish on all surfaces resists damage and extends cylinder life
- Handles and CR400 couplers included on all models
- Steel base plate and saddle for protection against load-induced damage
- Integral stop ring prevents plunger over-travel and is capable of withstanding the full cylinder capacity
- Built-in safety valve prevents accidental over-pressurization.

▼ An RAR506 was easy to position under a bulldozer for repair of frame member.



Cylinder Capacity @ 700 bar ton	Stroke (mm)	Model Number	Max. Cylinder Capacity (kN) Push	Cylinder Effective Area (cm ²)		Oil Capacity (cm ³)	
				Push	Pull	Push	Pull
20	50	RAR202	218	31,2	18,6	156	93
	100	RAR204	218	31,2	18,6	312	186
	150	RAR206	218	31,2	18,6	468	279
	200	RAR208	218	31,2	18,6	624	372
	250	RAR2010	218	31,2	18,6	780	465
30	50	RAR302	309	44,2	24,5	221	123
	100	RAR304	309	44,2	24,5	442	245
	150	RAR306	309	44,2	24,5	663	368
	200	RAR308	309	44,2	24,5	884	490
	250	RAR3010	309	44,2	24,5	1105	613
50	50	RAR502	496	70,9	26,7	354	134
	100	RAR504	496	70,9	26,7	709	267
	150	RAR506	496	70,9	26,7	1063	401
	200	RAR508	496	70,9	26,7	1417	534
	250	RAR5010	496	70,9	26,7	1771	668
100	50	RAR1002	1002	143,1	79,5	715	398
	100	RAR1004	1002	143,1	79,5	1431	795
	150	RAR1006	1002	143,1	79,5	2147	1193
	200	RAR1008	1002	143,1	79,5	2863	1590
	250	RAR10010	1002	143,1	79,5	3578	1988
150	50	RAR1502	1589	227,0	132,0	1135	660
	100	RAR1504	1589	227,0	132,0	2270	1320
	150	RAR1506	1589	227,0	132,0	3405	1980
	200	RAR1508	1589	227,0	132,0	4540	2640
	250	RAR15010	1589	227,0	132,0	5675	3300

Double-Acting Aluminium Cylinders

Optional Bolt-on Tilt Saddle Dimensions (mm)

For Cylinder Model / Capacity ton	Tilt Saddle Model Number	Tilt Saddle Diameter	Addition to Collapsed Height
		J1	A1
RAR20	CATS20	42	10
RAR30	CATS30	55	11
RAR50	CATS50	71	14
RAR100	CATS101	71	10
RAR150	CATS150	97	19

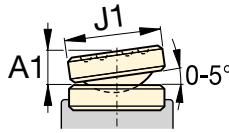

Steel Base Plate Mounting Holes

Cylinder Model / Capacity ton	Bolt Circle U (mm)	Thread V (mm)	Thread Depth ¹⁾ Z (mm)
RAR20	93	M6	12
RAR30	105	M6	12
RAR50	110	M6	12
RAR100	165	M6	12
RAR150	200	M6	12

¹⁾ Including Base Plate Height of 6 mm and four (4) base plate bolts M6.

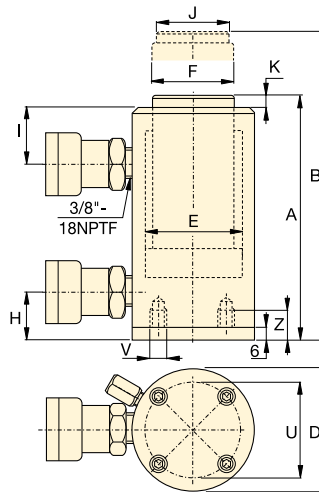

RAR Series



Capacity:

20 - 150 ton

Stroke:

50 - 250 mm

Maximum Operating Pressure:

700 bar

Collapsed Height	Extended Height	Outside Diameter	Cylinder Bore Diameter	Plunger Diameter	Bottom to Advance Port	Top to Retract Port	Saddle Diameter	Saddle Protrusion from Plunger		Model Number
A (mm)	B (mm)	D (mm)	E (mm)	F (mm)	H (mm)	I (mm)	J (mm)	K (mm)	(kg)	
189	239	113	63	40	30	50	30	3	7,4	RAR202
239	339	113	63	40	30	50	30	3	8,0	RAR204
289	439	113	63	40	30	50	30	3	8,6	RAR206
339	539	113	63	40	30	50	30	3	9,2	RAR208
389	639	113	63	40	30	50	30	3	9,8	RAR2010
201	251	125	75	50	30	55	40	3	8,6	RAR302
251	351	125	75	50	30	55	40	3	9,5	RAR304
301	451	125	75	50	30	55	40	3	10,4	RAR306
351	551	125	75	50	30	55	40	3	11,3	RAR308
401	651	125	75	50	30	55	40	3	12,2	RAR3010
201	251	145	95	75	30	56	50	3	11,1	RAR502
251	351	145	95	75	30	56	50	3	12,7	RAR504
301	451	145	95	75	30	56	50	3	14,3	RAR506
351	551	145	95	75	30	56	50	3	15,9	RAR508
401	651	145	95	75	30	56	50	3	17,5	RAR5010
251	301	185	135	90	43	80	75	3	16,4	RAR1002
301	401	185	135	90	43	80	75	3	19,3	RAR1004
351	501	185	135	90	43	80	75	3	22,2	RAR1006
401	601	185	135	90	43	80	75	3	25,1	RAR1008
451	701	185	135	90	43	80	75	3	28,0	RAR10010
248	298	230	170	110	38	75	94	3	24,2	RAR1502
298	398	230	170	110	38	75	94	3	28,9	RAR1504
348	498	230	170	110	38	75	94	3	33,2	RAR1506
398	598	230	170	110	38	75	94	3	37,9	RAR1508
448	698	230	170	110	38	75	94	3	42,6	RAR15010

▼ CULP50 Ultra-Flat Cylinder, with Stop Ring



- Up to 4% side load of maximum capacity
- Stop ring for maximum stroke limitation
- Extremely low collapsed height
- Nitrocarburized surface treatment for harsh conditions.

▼ The Ultra-Flat cylinders are designed for applications where high lifting forces are required in confined spaces starting at 2,8 cm.

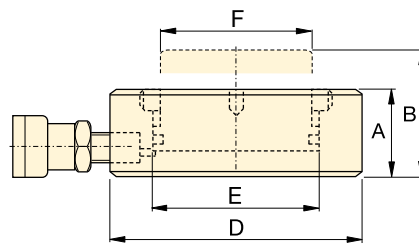

CULP Series

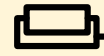

Capacity:

10 - 100 ton

Stroke:

6 mm

Maximum Operating Pressure:

700 bar



IMPORTANT!

All Ultra-Flat Cylinders require a solid lifting surface for correct support. The use of these flat cylinders on surfaces such as sand, mud or dirt, may result in cylinder damage.



INCORRECT!

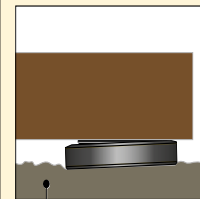

Rough soil



CORRECT!

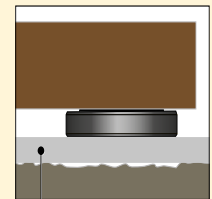

Flat lifting surface

For more safety instructions see our 'Yellow Pages'.

Page: **406**



Hoses

Enerpac offers a complete line of high quality hydraulic hoses. To ensure the integrity of your system, specify only Enerpac

hydraulic hoses.

Page: **128**

Cylinder Capacity @ 700 bar	Stroke	Model Number	Cylinder Effective Area	Oil Capacity	Collapsed Height	Extended Height	Outside Diameter	Cylinder Bore Diameter	Plunger Diameter	
ton (kN)	(mm)		(cm ²)	(cm ³)	A (mm)	B (mm)	D (mm)	E (mm)	F (mm)	(kg)
10 (97)	6	CULP10 ¹⁾	13,9	8,3	27,5	33,5	72	42	38	1,0
20 (198)	6	CULP20 ¹⁾	28,3	17,0	32,0	38,0	90	60	55	1,7
30 (310)	6	CULP30 ¹⁾	44,2	26,5	35,0	41,0	105	75	67	2,5
50 (550)	6	CULP50 ¹⁾	78,5	47,1	44,5	50,5	140	100	90	5,4
100 (1078)	6	CULP100 ²⁾	153,9	92,5	65,0	71,0	195	140	125	11,5

¹⁾ Coupler AR630 including dustcap: use HB7206 hose including AH630 coupler to connect to your pump.

²⁾ Coupler CR400 including dustcap: use HC-Series hose including CH604 coupler to connect to your pump.

High Tonnage, Ultra-Flat Cylinders

▼ CUSP-Series, Ultra-Flat High Tonnage Cylinders, integrated tilting function.



- Up to 4% side load of maximum capacity
- Extremely low collapsed height
- Integrated tilting function up to 4 degrees to evenly distribute the load
- Nitrocarburized surface treatment for harsh conditions
- “Red Line” for visual maximum stroke indication.

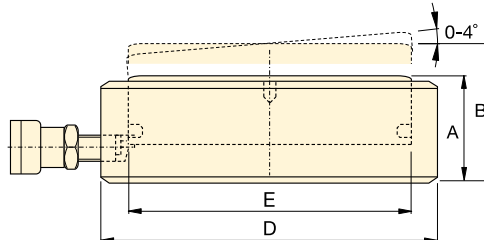

CUSP Series

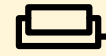

Capacity:

10 - 1000 ton

Stroke Straight / Tilted Stroke:

7 - 17 mm / 6 - 10 mm

Integrated:

Tilting Function

Maximum Operating Pressure:

700 bar



IMPORTANT!

CUSP-Cylinders DO NOT have a Stop Ring for stroke limitation!



IMPORTANT!

All Ultra-Flat Cylinders require a solid lifting surface for correct support. The use of these flat cylinders on surfaces such as sand, mud or dirt, may result in cylinder damage.

See instructions on page 22 or more safety instructions in our Yellow Pages.

Page: **406**

Cylinder Capacity @ 700 bar	Tilted Stroke	Straight Stroke	Model Number	Tilting +/-	Cylinder Effective Area	Oil Capacity	Collapsed Height	Extended Height	Cylinder Outside Diameter	Cylinder Bore Diameter	
ton (kN)	(mm)	(mm)		(degree)	(cm ²)	(cm ³)	A (mm)	B (mm)	D (mm)	E (mm)	(kg)
10 (97)	6	6,7	CUSP10 ¹⁾	2	13,9	9,3	35,5	41,5	72	42	1,2
20 (198)	6	7,0	CUSP20 ¹⁾	2	28,3	19,8	40,5	46,5	90	60	1,9
30 (310)	6	7,3	CUSP30 ¹⁾	2	44,2	32,1	42,5	48,5	105	75	2,7
50 (550)	10	13,3	CUSP50 ¹⁾	4	78,5	104	57,0	67,0	130	100	5,6
75 (792)	10	14,0	CUSP75 ¹⁾	4	113,1	158	60,5	70,5	150	120	8,0
100 (1078)	10	14,7	CUSP100 ²⁾	4	153,9	226	63,5	73,5	170	140	10,8
150 (1589)	10	14,3	CUSP150 ²⁾	3	227,0	324	65,0	75,0	200	170	15,3
200 (2090)	10	14,9	CUSP200 ²⁾	3	298,6	446	69,0	79,0	229	195	21,5
250 (2542)	10	15,5	CUSP250 ²⁾	3	363,1	569	72,5	82,5	252	215	27,3
300 (3167)	10	14,1	CUSP300 ²⁾	2	452,4	637	72,5	82,5	282	240	34,4
400 (4008)	10	14,6	CUSP400 ²⁾	2	572,6	837	77,5	87,5	316	270	46,2
500 (5115)	10	15,2	CUSP500 ²⁾	2	730,6	1111	82,5	92,5	356	305	62,7
600 (5987)	10	15,6	CUSP600 ²⁾	2	855,3	1334	87,5	97,5	386	330	78,4
750 (7527)	10	16,3	CUSP750 ²⁾	2	1075,2	1757	93,5	103,5	432	370	105,2
1000 (10.165)	10	17,4	CUSP1000 ²⁾	2	1452,2	2531	103,0	113,0	502	430	157,0

¹⁾ Coupler AR630 including dustcap: Use HB7206 hose including AH630 coupler to connect to your pump.

²⁾ Coupler CR400 including dustcap: Use HC-Series hose including CH604 coupler to connect to your pump.

▼ LPL-Series, Low-Height Lock Nut Cylinders



- Lock nut provides mechanical load holding for a safe work environment
- Integrated tilt saddle allows for up to 5 degrees of misalignment
- Extreme low height for use in confined areas
- Side-load resistance 5-10% of maximum capacity
- Overflow port as stroke limiter to prevent plunger blow-out
- Single-acting, gravity-return.

▼ Only the extreme low-height LPL-cylinder fits in this confined area to lift the construction. The lock nut provides positive and safe mechanical load holding over a long period of time.



Integrated Tilt Saddles

All LPL-Series cylinders include integral tilt saddles with maximum tilt angles up to 5°.



The Summit Edition

Innovation is at the heart of the new Summit Edition of cylinders, delivering the high quality construction that you expect from Enerpac. The durability ensures your job gets done safely and reliably.

- Replaceable plunger support bearing adds support for eccentric loads *
- Nitrocarburization surface treatment for improved load and wear resistance and corrosion protection
- Low wear, high pressure seals provide longer service life.

* Eccentric load (or "side-load") is inevitable in heavy lifting. Our unique Summit Edition features provide the ultimate protection against side load. Increased bearing surface maintains stability and nitrocarburization treatment prevents scoring on the inside of the cylinder. Side-load poses a real problem.... our new cylinder features are the solution!

Cylinder Capacity	Stroke	Model Number	Maximum Cylinder Capacity at 700 bar ton (kN)	Side-load Resistance of Maximum Capacity	Cylinder Effective Area
ton	(mm)				(cm ²)
60	50	LPL602	62 (606)	10%	86,6
100	50	LPL1002	102 (1002)	10%	143,1
150	45	LPL1602	162 (1589)	8%	227,0
200	45	LPL2002	202 (1985)	8%	283,5
250	45	LPL2502	259 (2541)	5%	363,1
400	45	LPL4002	409 (4008)	5%	572,6
500	45	LPL5002	522 (5114)	5%	730,6

Single-Acting, Low-Height Lock Nut Cylinders



IMPORTANT!

All LPL-Series cylinders require a solid lifting surface for correct support. The use of these cylinders on surfaces such as sand, mud or dirt, may result in cylinder damage.

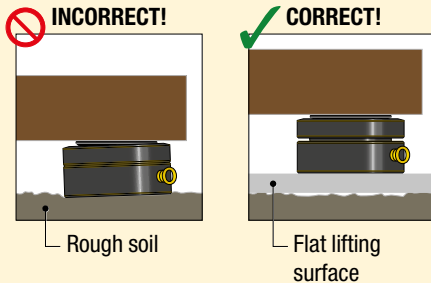

For more safety instructions see our 'Learning Center' on www.enerpac.com

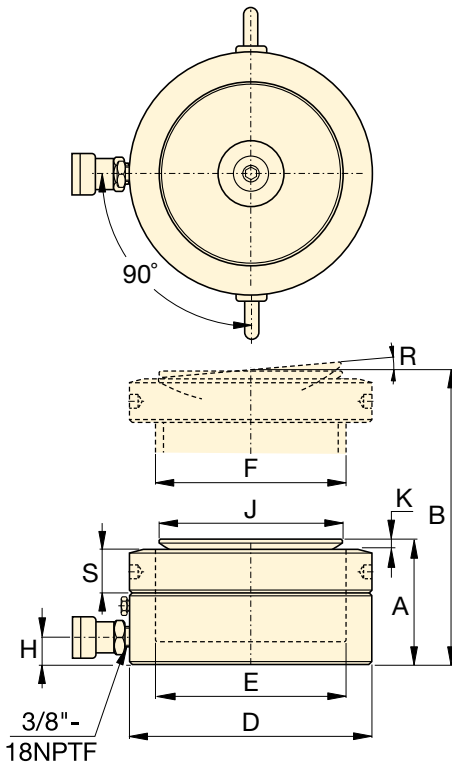

LPL Series



Capacity:

60 - 500 ton

Stroke:

45 - 50 mm

Maximum Operating Pressure:

700 bar



Longer Stroke Lock Nut Cylinders

For longer stroke applications **HCL and HCRL-Series** lock nut cylinders are the perfect choice.

Page: 46



SFP-Series, Split-Flow Pumps

SFP-Series Pumps with multiple outlets with equal oil flow. For lifting and lowering applications on multiple points

these pumps are a far better alternative than using separately operated pumps.

Page: 406



Synchronous Lifting Systems

EVO-Series pumps the multi-functional lifting system and multiple lift point capabilities.

Page: 350

Oil Capacity	Collapsed Height	Extended Height	Outside Diameter	Cylinder Bore Diameter	Plunger Diameter	Base to Advance Port	Saddle Diameter	Saddle Protrusion from Plgr.	Saddle Max. Tilt Angle	Lock Nut Height		Model Number
(cm ³)	A (mm)	B (mm)	D (mm)	E (mm)	F (mm)	H (mm)	J (mm)	K (mm)	R	S (mm)	(kg)	
433,0	126	176	140	105	Tr 105 x 4	19	96	7	5°	28	15	LPL602
715,7	137	187	173	135	Tr 135 x 6	21	126	8	5°	31	25	LPL1002
1021,4	148	193	220	170	Tr 170 x 6	27	160	9	5°	40	43	LPL1602
1275,9	155	200	245	190	Tr 190 x 6	30	180	10	5°	43	55	LPL2002
1633,7	159	204	275	215	Tr 215 x 6	32	200	12	5°	43	70	LPL2502
2576,5	178	223	350	270	Tr 270 x 6	40	250	12	4°	55	129	LPL4002
3287,8	192	237	400	305	Tr 305 x 6	49	290	10	3°	61,5	183	LPL5002

▼ Shown from left to right: RSM1000, RSM300, RSM50, RCS1002, RCS302



Maximum Power-to-Height Ratio



Saddles

All RCS-Series cylinders have plunger mounting holes for installation of tilt saddles. See table for selection and dimensional information.

Page: 27



Low Clearance Lifting

The LW-Series Lifting Wedges and SOH-Series Machine Lifts are the perfect choice for lifting the first few millimeters.

Page: 188

RSM-series, Low-Height Cylinders

- Compact, flat design for use where most other cylinders will not fit
- Single-acting, spring return
- RSM750, 1000 and 1500 have handles for easy carrying
- Mounting holes permit easy fixturing
- Baked enamel finish for increased corrosion resistance
- CR400 coupler and dust cap included on all models¹⁾
- Hard chrome plated high quality steel plungers
- Grooved plunger ends require no saddle.

RCS-series, Low-Height Cylinders

- Lightweight, low profile design for use in confined spaces
- Single-acting, spring return
- Baked enamel finish for increased corrosion resistance
- Plunger wiper reduces contamination, extending cylinder life
- CR400 coupler and dust cap included on all models
- Grooved plunger end with threaded holes for mounting tilt saddles
- Integral handle on RCS1002 for easy carrying
- Plated steel plungers.

▼ Only a couple of centimeters will do for an RSM-cylinder to lift a large construction.

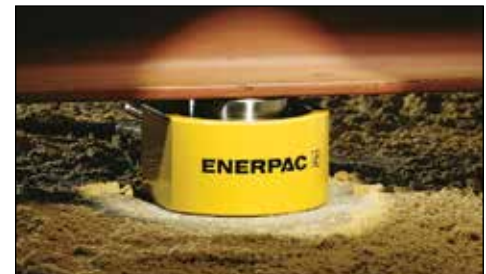

Cyl. Capacity	Stroke	Model Number	Cylinder Effective Area	Oil Capacity
ton (kN)	(mm)		(cm ²)	(cm ³)
5 (45)	6	RSM50 ¹⁾	6,5	4
10 (101)	11	RSM100 *	14,5	18
20 (201)	11	RSM200 *	28,7	32
30 (295)	13	RSM300 *	42,1	55
45 (435)	16	RSM500 *	62,1	99
75 (718)	16	RSM750	102,6	164
90 (887)	16	RSM1000	126,7	203
150 (1386)	16	RSM1500	198,1	317
10 (101)	38	RCS101 *	14,5	55
20 (201)	45	RCS201 *	28,7	129
30 (295)	62	RCS302 *	42,1	261
45 (435)	60	RCS502 *	62,1	373
90 (887)	57	RCS1002 *	126,7	722

¹⁾ RSM50 is fitted with an AR400 coupler.

* Available as set, see note on next page.

Single-Acting, Low-Height Cylinders

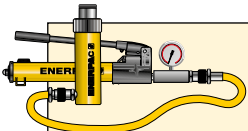

Cylinder-Pump Sets

All cylinders marked with an * are available as sets (cylinder, gauge, couplers, hose and pump) for your ordering convenience.

Page: **62**

Optional Bolt On Tilt Saddle Dimensions (mm)

For Cylinder Model:	Model Number	J1	A1 *
RCS101	CATS13	35	20
RCS201, 302, 502	CATS53	50	26
RCS1002	CATS103	71	35

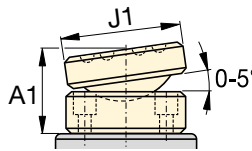

* A1 = Addition to Collapsed Height.

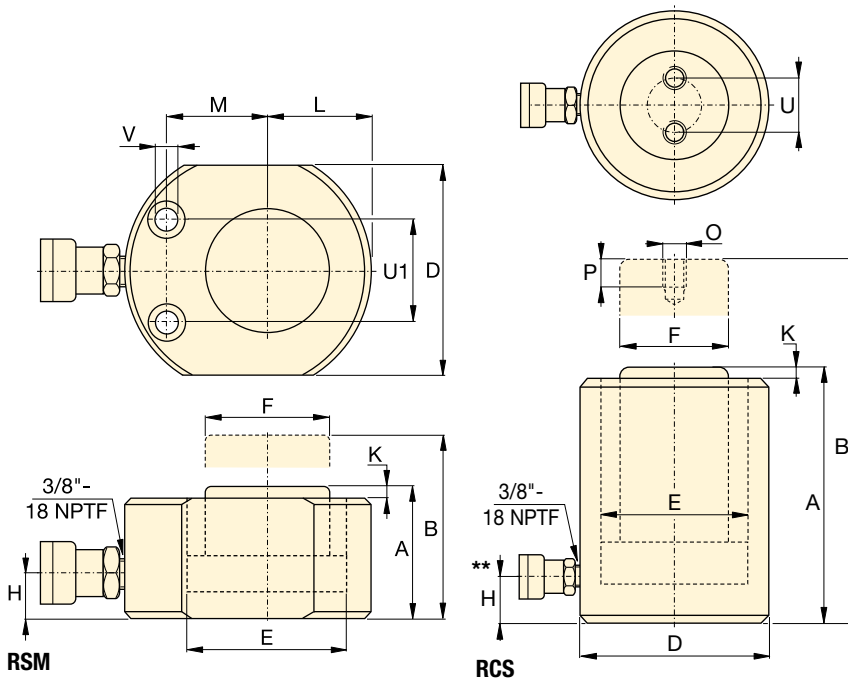

RSM, RCS Series



Capacity:

5 - 150 ton

Stroke:

6 - 62 mm

Maximum Operating Pressure:

700 bar



Power Box

Tool box with hand pump, gauge adaptor assembly, hose and RSM or RCS-cylinders.

Page: **65**

RSM Cylinder Mounting Hole Dimensions (mm)

Model Number	Bolt Circle U1	Hole Dia. V	Counter Bore Dia.	Counter Bore Depth
RSM50	28,5	5,5	9,1	4,3
RSM100	36,6	7,1	10,7	7,9
RSM200	49,3	10,0	15,1	9,9
RSM300	52,3	10,0	15,9	11,2
RSM500	66,5	11,0	19,0	12,7
RSM750	76,2	13,5	20,6	14,2
RSM1000	76,2	13,5	20,6	14,2
RSM1500	117,3	13,5	20,6	14,2

Collapsed Height	Extended Height	Outside Diameter	Cylinder Bore Dia.	Plunger Dia.	Base to Advance Port	Plunger Protrusion from Base	Plunger to Base	Plunger to Mtg. Hole	Thread	Thread Depth	Bolt Circle	Weight	Model Number
A (mm)	B (mm)	D (mm)	E (mm)	F (mm)	H (mm)	K (mm)	L (mm)	M (mm)	O (mm)	P (mm)	U (mm)	(kg)	
32	38	58 x 41	28,7	25,4	16	1	20	22	-	-	-	1,0	RSM50 ¹⁾
43	54	82 x 55	42,9	38,1	19	1	27	34	-	-	-	1,4	RSM100 *
51	62	101 x 76	60,5	50,8	19	1	39	39	-	-	-	3,1	RSM200 *
58	71	117 x 95	73,2	63,4	19	2	47	44	-	-	-	4,5	RSM300 *
66	82	140 x 114	88,9	69,8	19	2	57	53	-	-	-	6,8	RSM500 *
79	95	165 x 139	114,3	82,6	19	2	69	66	-	-	-	11,3	RSM750
85	101	178 x 153	127,0	92,2	19	2	76	74	-	-	-	14,5	RSM1000
100	116	215 x 190	158,8	114,3	23	2	95	82	-	-	-	26,3	RSM1500
88	126	69	42,9	38,1	17	5	-	-	M4	8	26	2,7	RCS101 *
98	143	92	60,5	50,8	17	3	-	-	M5	8	40	5,0	RCS201 *
117	179	101	73,2	66,5	19	3	-	-	M5	8	40	6,8	RCS302 *
122	182	124	88,9	69,8	23	2	-	-	M5	8	40	10,0	RCS502 *
141	198	165	127,0	92,2	31	1	-	-	M8	10	55	20,7	RCS1002 *

** 5° angle position of coupler on RCS101, 201, 302.

▼ RLT-Series, Low-Height Telescopic Cylinder



- **Single-acting, load-return**
- **Nitrocarburized surface treatment inside and out provides corrosion protection**
- **For use in confined spaces: machinery positioning, tool fastening**
- **Mounting bolt holes for easy fixing**
- **Up to 3% side-load of maximum capacity**
- **Design safety factor complies with ASME B30.1 & EN1494**
- **CR400 coupler for compatibility with standard product**
- **High-Alloy steel for maximum strength.**

For longer cylinder strokes in confined spaces



RLT-Series, Low-Height Telescopic Cylinders

Enerpac compact, low-height telescopic cylinders are available with two or three pistons, and can lift loads up to 40 mm in a single movement.

Nitrocarburization surface treatment for improved wear resistance and corrosion protection for increased safety and longer service life in harsh conditions. The longer stroke length of telescopic cylinders will save you time and simplify projects by moving a load a greater distance and eliminating the use of temporary cribbing.



Multi-Stage Cylinders

1st Stage: maximum load capacity at lower stroke.

2nd Stage: extended stroke with lower capacity than the 1st stage.

Final Stage: maximum stroke extension with lowest capacity.



Cylinder Capacity at Maximum Stroke ton (kN)	Maximum Stroke (mm)	Model Number	Collapsed Height	Extended Height	Oil Capacity (cm ³)
			A (mm)	B (mm)	
4,4 (43)	17	RLT40	45,0	62,0	21
4,4 (43)	23	RLT41	54,0	77,0	51
11,4 (111)	18	RLT110	54,5	72,5	48
11,4 (111)	40	RLT111	89,0	129,0	241
23,7 (232)	27	RLT230	75,0	102,0	150
23,7 (232)	32	RLT231	96,0	128,0	303
31,5 (309)	29	RLT311	89,0	118,0	224
50,6 (496)	26	RLT501	96,0	122,0	283
74,1 (727)	26	RLT741	114,0	140,0	426

Low-Height Telescopic Cylinders, Single-Acting



Assisted-return Pumps with Venturi Valve Technology

To improve productivity and plunger retraction,

Enerpac offers valve configurations designed to accelerate your cylinder retraction speeds, ZU4 and ZE-Series pumps feature **Venturi Valve Technology** to facilitate the faster return of single-acting load and spring-return cylinders. See enerpac.com for details.

Page: 123



4-way Manifold assembly

Offering ease of portability and convenience with an ergonomic robust design, ready for use. Enerpac's

CR400 female couplers on all ports allow the manifold to be quickly connected to up to 4 cylinders. Glycerine filled, 700 bar gauges allow operators to work safely. All protected by the robust protection frame.

Manifold Type (Used for cylinders)	Model Number
4x Single-acting	AMGC41
4x Double-acting	AMGC42

Page: 132

RLT Series



Capacity:

4,4 - 74,1 ton

Stroke:

17 - 40 mm

Maximum Operating Pressure:

700 bar



WARNING: If several telescopic cylinders need to be controlled simultaneously Enerpac recommend the use of **EVOP** or **EVO-Series**

Synchronous Lifting Pumps. Enerpac advise not to use SFP-Series Split-Flow pumps to operate several telescopic cylinders at a time due to the volume difference on the different stages.

Page: 350

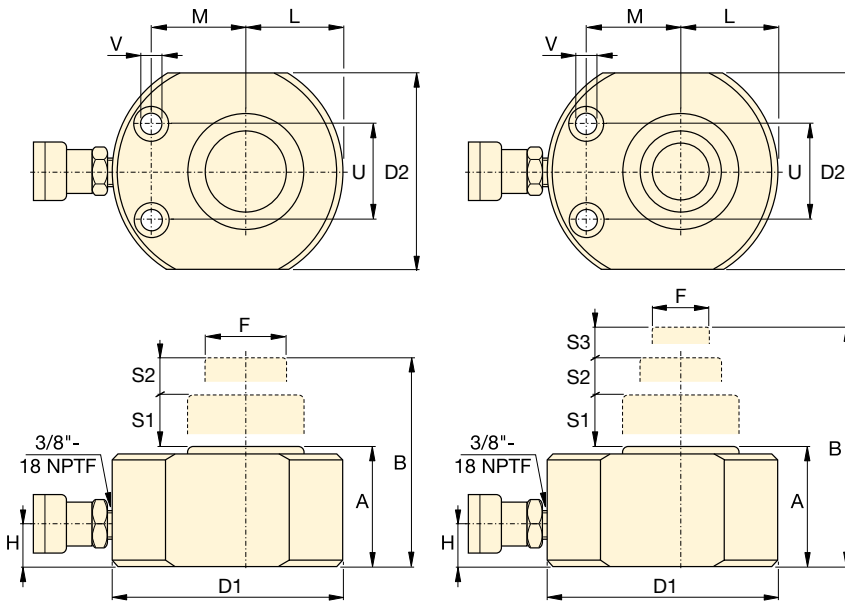

RLT-Cylinders

Mounting Hole Dimensions (mm)

Model Number	Bolt Distance	Hole Diameter	Counter Bore Diameter	Counter Bore Depth
	U	V		
RLT40	37	6,5	11	7
RLT41	50	9,0	14	9
RLT110	50	9,0	14	9
RLT111	76	13,0	20	13
RLT230	67	13,0	20	13
RLT231	76	6,5	11	7
RLT311	76	13,0	20	13
RLT501	76	6,5	11	7
RLT741	117	9,0	14	9

1st Stage		2nd Stage		3rd Stage		Outside Diameter D1 x D2 (mm)	Plunger Diameter F (mm)	Bottom to Advance Port H (mm)	Plunger to Base L (mm)	Plunger to Mounting Hole M (mm)	 (kg)	Model Number
Capacity ton (kN)	Stroke S1 (mm)	Capacity ton (kN)	Stroke S2 (mm)	Capacity ton (kN)	Stroke S3 (mm)							
11,4 (111)	11	4,4 (43)	6	-	-	83 x 56	25	20	29,0	33	1,8	RLT40
23,7 (232)	11	11,4 (111)	7	4,4 (43)	5	102 x 80	25	20	41,0	39	3,1	RLT41
23,7 (232)	11	11,4 (111)	7	-	-	102 x 80	38	20	41,0	39	3,0	RLT110
74,1 (727)	16	31,5 (309)	13	11,4 (111)	11	165 x 140	38	25	70,5	66	13,1	RLT111
50,6 (496)	16	23,7 (232)	11	-	-	140 x 114	57	20	58,0	56	7,6	RLT230
94,7 (929)	16	50,6 (496)	10	23,7 (232)	6	178 x 162	57	29	89,0	70	17,3	RLT231
74,1 (727)	16	31,5 (309)	13	-	-	165 x 140	60	25	70,5	66	13,0	RLT311
94,7 (929)	16	50,6 (496)	10	-	-	178 x 162	78	29	89,0	70	17,3	RLT501
143,5 (1407)	16	74,1 (727)	10	-	-	216 x 196	95	35	108,0	78	30,4	RLT741

▼ RT3311 Telescopic Cylinder (shown with plunger extended and retracted)



- Nitrocarburized surface treatment inside and out provides corrosion protection
- 3% side-load of full capacity
- Double or triple wear bearings support lifting stages
- Tilting saddles with 5 degrees of maximum tilt standard on all models
- Design Safety factor complies with ASME B30.1 & EN1494
- Certified lifting eyes for safe handling and positioning
- CR400 coupler for compatibility with standard product
- Steel cylinder base for maximum strength.

Moving a load a greater distance



RT-Series, Multi-Stage Cylinders

Enerpac compact, multi-stage telescopic cylinders are available with two or three pistons, and can lift loads up to 600 mm in a single movement.

Nitrocarburized surface treatment inside and out provides unparalleled sideload resistance and corrosion protection for safe use in the harshest conditions. The longer stroke length of telescopic cylinders will save you time and simplify projects by moving a load a greater distance and eliminating the use of temporary cribbing.

Multi-Stage Cylinders

1st Stage: maximum load capacity at lowest maximum stroke

2nd Stage: extended stroke but at lower maximum capacity than the 1st stage

Final Stage: maximum stroke extension but lowest maximum capacity.

WARNING: If several telescopic cylinders need to be controlled simultaneously Enerpac recommend the use of EVO or EVOB-Series Synchronous Lifting Pumps. Enerpac advise not to use SFP-Series Split-Flow pumps to operate several telescopic cylinders at a time due to the volume difference on the different stages.



Tilt Saddles

All RT-Series cylinders include integral tilt saddles with maximum tilt angles up to 5 degree.



◀ *The longer stroke length of telescopic cylinders will save you time and simplify projects by moving a load a greater distance and eliminating the use of temporary cribbing.*

Cylinder Capacity at Maximum Stroke ton (kN)	Maximum Stroke (mm)	Model Number	Collapsed Height	
			A (mm)	B (mm)
14,0 (137)	270	RT1510	283	553
		RT1817	345	780
20,2 (198)	300	RT2111	317	617
	500	RT2119	395	895
31,5 (309)	300	RT3311	352	652
	600	RT3323	476	1076

Multi-Stage Telescopic Cylinders, Single-Acting, Load Return

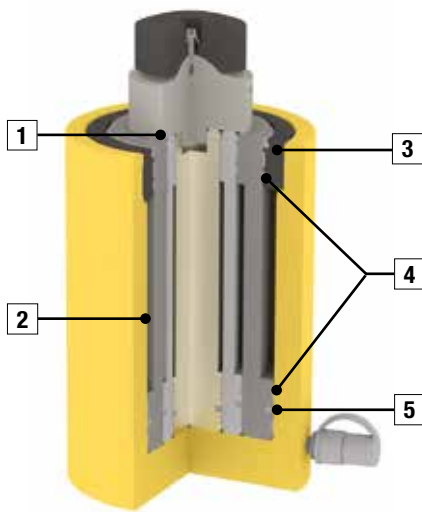

- 1 **Wiper Ring** on each stage to minimize contamination.
- 2 **Nitrocarburized Coating** for maximum corrosion protection and surface hardness. Exterior in nitrided and Enerpac yellow epoxy.
- 3 **Stop Ring** full load capable to prevent plunger overstroke.
- 4 **Wear Bearings.** Double or triple wear bearings for maximum sideload capability and wear resistance.
- 5 **Seals** for maximum compliance and high wear resistance.

RT Series



Capacity:
14 - 31,5 ton

Stroke:
270 - 600 mm

Maximum Operating Pressure:
700 bar

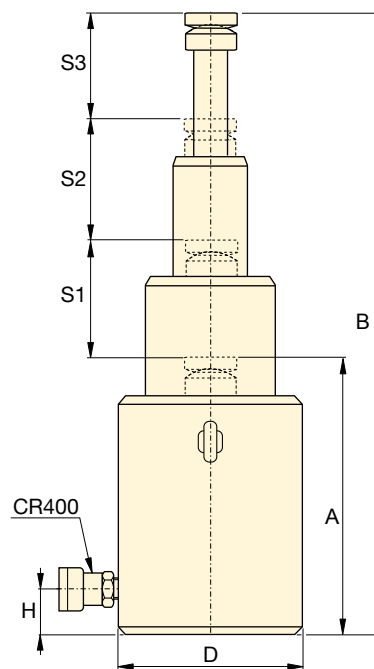
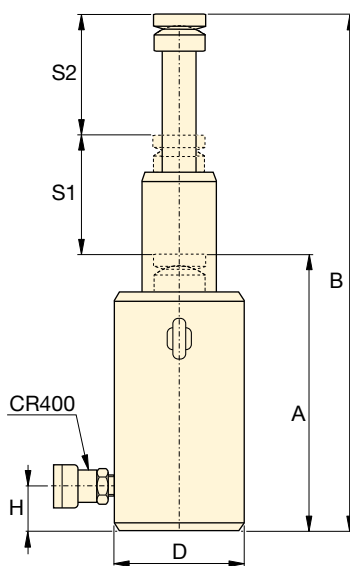
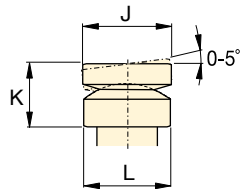

Assisted-return Pumps with Venturi Valve Technology

To improve productivity and plunger retraction, Enerpac offers valve configurations designed to accelerate your cylinder retraction speeds, ZU4 and ZE-Series pumps feature **Venturi Valve Technology** to facilitate the faster return of single-acting load and spring-return cylinders. See enerpac.com for details.

Page: 123



Hoses

Enerpac offers a complete line of high quality hydraulic hoses. To ensure the integrity of your system, specify only Enerpac hydraulic hoses.

Page: 128

Oil Capacity (cm ³)	1st Stage		2nd Stage		3rd Stage		Outside Diameter D (mm)	Bottom to Advance Port H (mm)	Saddle Diameter J (mm)	Saddle Protrusion from Plgr. K (mm)	Saddle Support Diameter L (mm)	Model Number
	Capacity ton (kN)	Stroke S1 (mm)	Capacity ton (kN)	Stroke S2 (mm)	Capacity ton (kN)	Stroke S3 (mm)						
944	36 (352)	135	14 (137)	135	-	-	110	20	60	49	60	15,1 RT1510
3092	95 (929)	145	41 (397)	145	17,0 (166)	145	170	27	80	73	85	40,3 RT1817
1487	51 (496)	150	20 (198)	150	-	-	125	23	60	53	66	21,8 RT2111
4661	126 (1237)	170	51 (496)	170	20,2 (198)	160	200	34	90	83	100	67,3 RT2119
2359	81 (792)	150	32 (309)	150	-	-	160	25	80	66	89	39,9 RT3311
8816	202 (1985)	200	81 (792)	200	31,5 (309)	200	250	44	110	111	123	124,0 RT3323

▼ Shown from left to right: BRC25, BRC46, BRP306, BRP606, BRP106C



- High strength alloy steel construction
- Hard chrome-plated plunger for long life
- Replaceable links on BRP-models
- Baked enamel finish for increased corrosion resistance
- CR400 coupler and dust cap included on all models
- Plunger wiper reduces contamination, extending cylinder life
- Single-acting, spring return.

The Ultimate in Pulling Power



Gauges

Minimize the risk of overloading and ensure long, dependable service from your equipment. Refer to the System Components

Section for a full range of gauges.

Page: 127



Attachments and Accessories

BRC25 and BRC46 units have base, collar and plunger threads to affix a range of optional attachments and accessories, such as chains, saddles and extension tubes.

Page: 181

▼ Lifting mining conveyor belt using pull cylinders for bearing maintenance.



▼ To lift a load bearing mast into place, BRP-Series cylinders were used to tension the supporting cables.



Single-Acting, Pull Cylinders

BRC Cylinder Mounting Dimensions (mm)				
Model Number	Base Mounting Hole V	Collar Thread W	Collar Thd. Lgth. X	Mtg. Thd. Lgth. Z
BRC-25	3/4" - 14 NPT	1 1/2" - 16 UN	24	17
BRC-46	1 1/4" - 11 1/2 NPT	2 1/4" - 14 UN	26	24
BRC-106	M30 x 2	M85 x 2	25	24

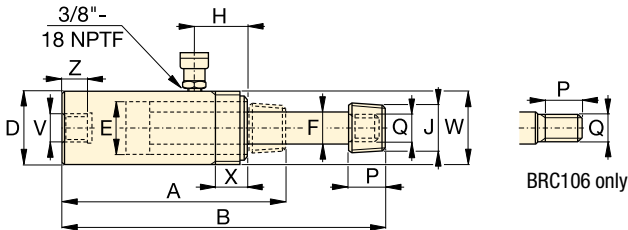

BRC25, 46, 106

**BRC,
BRP
Series**



Capacity:

2,5 - 50 ton

Stroke:

127 - 154 mm

Maximum Operating Pressure:

700 bar

Cylinder Capacity	Stroke	Model Number	Cylinder Effective Area	Oil Capacity	Coll. Height	Ext. Height	Outside Dia.	Cylinder Bore Dia.	Plunger Dia.	Top to Inlet Port H	Saddle Diameter J (NPT)	Plunger Thread Length P (mm)	Plunger Outside Thread Q	
ton (kN)	(mm)		(cm ²)	(cm ³)	A (mm)	B (mm)	D (mm)	E (mm)	F (mm)	H (mm)				(kg)
2,5 (24)	127	BRC25	3,5	45	264	391	48	28,4	19,0	45	3/4" - 14	28	1 1/16" - 24	1,8
5 (51)	140	BRC46	7,3	101	301	441	57	42,9	30,2	42	1 1/4" - 11 1/2	32	1 3/16" - 16	4,5
10 (105)	151	BRC106	15,0	228	289	440	85	54,1	31,8	39	-	25	M30x2	9,5

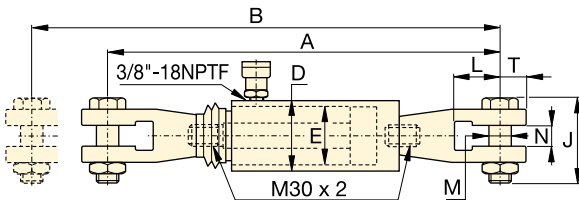

BRP106C

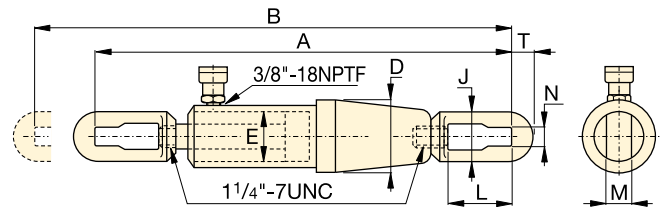

BRP306

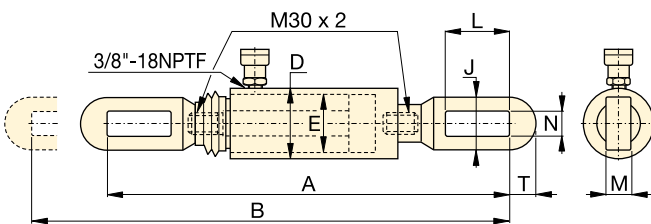

BRP106L

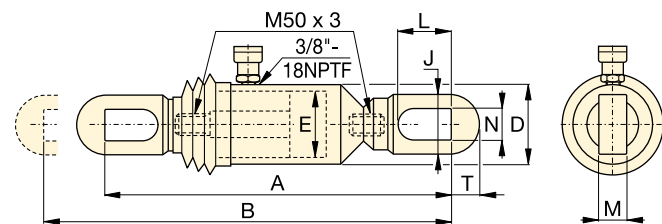

BRP606

Cylinder Capacity	Stroke	Model Number	Cylinder Effective Area	Oil Capacity	Coll. Height	Ext. Height	Outside Dia.	Cyl. Bore Dia.	Link Height	Link Opening L	Link Thickness M	Link Width N	Slot to Link End T	
ton (kN)	(mm)		(cm ²)	(cm ³)	A (mm)	B (mm)	D (mm)	E (mm)	J (mm)	L (mm)	M (mm)	N (mm)	T (mm)	(kg)
10 (110)	150	BRP106C	15,8	238	601	751	85	54,1	105	87	30	35	32	15,3
	150	BRP106L	15,8	238	573	723	85	54,1	64	119	22	30	32	13,3
30 (325)	154	BRP306	46,4	715	1110	1264	137	88,9	114	155	35	43	55	63,1
50 (506)	153	BRP606	72,1	1096	718	871	140	110,1	130	151	40	48	65	58,3

▼ Shown from left to right: RCH306, RCH120, RCH1003



- Hollow plunger design allows for both, pull and push forces
- Single-acting, spring return
- Nickel-plated, floating center tube on models over 20 ton increases product life
- Baked enamel finish for increased corrosion resistance
- Collar threads for easy fixturing
- RCH120 includes AR630 coupler and has 1/4" NPTF port
- RCH121 and RCH1211 have FZ1630 reducer and AR630 coupler, all other models feature CR400 coupler.

▼ Hollow plunger cylinder RCH1003 used in an application for intermediate boom suspension on a dragline.



Versatility in Testing, Maintenance and Tensioning Applications

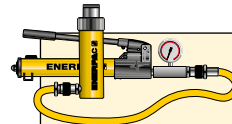

Cylinder-Pump Sets

All cylinders marked with an * are available as **sets** (cylinder, gauge, couplers, hose and pump) for your ordering convenience.

Page: 62



Ultra-Lightweight Aluminium Cylinders

If you need a higher cylinder capacity-to-weight-ratio the lightweight **RACH-Series** are the perfect choice.

Page: 16



Saddles

Most RCH-Series cylinders are equipped with smooth saddles. See table at next page for optional threaded saddles and all dimensional information.

Page: 35

Cylinder Capacity	Stroke	Model Number	Cylinder Effective Area	Oil Capacity
ton (kN)	(mm)		(cm ²)	(cm ³)
12 (125)	8	RCH120	17,9	14
	42	RCH121 *	17,9	75
	42	RCH1211	17,9	75
	76	RCH123	17,9	136
20 (215)	49	RCH202 *	30,7	150
	155	RCH206	30,7	476
30 (326)	64	RCH302 *	46,6	298
	155	RCH306	46,6	722
60 (576)	76	RCH603 *	82,3	626
	153	RCH606	82,3	1259
95 (931)	76	RCH1003 *	133,0	1011

* Available as set, see note on this page.

Single-Acting, Hollow Plunger Cylinders



Hoses

Enerpac offers a complete line of high quality hydraulic hoses. To ensure the integrity of your system, specify only Enerpac hydraulic hoses.

Page: **128**

RCH Series

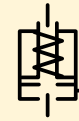

Capacity:

12 - 95 ton

Stroke:

8 - 155 mm

Center Hole Diameter:

19,5 - 79,0 mm

Maximum Operating Pressure:

700 bar

Optional Threaded Hollow Saddles

Saddle Type	Cylinder Model Number	Saddle Model Nr.	Saddle Dimensions (mm)		
			A	B	C
Threaded Hollow	RCH202, 206	HP2015	53	1" - 8	9
	RCH302, 306	HP3015	63	1¼" - 7	9
	RCH603, 606	HP5016	91	1½" - 5½	12
	RCH1003	HP10016	126	2½" - 8	13

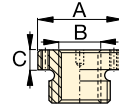

Smooth hollow saddles are standard on all RCH-models (except RCH120, RCH1211).

RCH121 and RCH1211 have a 47 mm dia. boss that protrudes 6 mm from base.

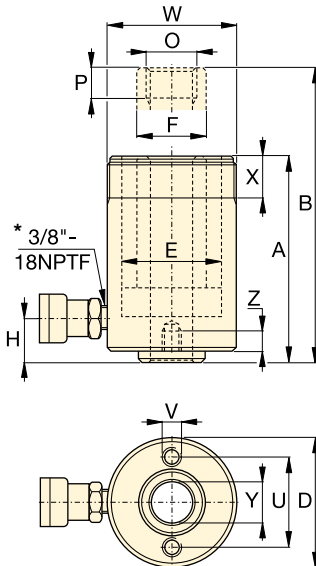

RCH120 to RCH123 models

* 1/4" NPTF for RCH120 only

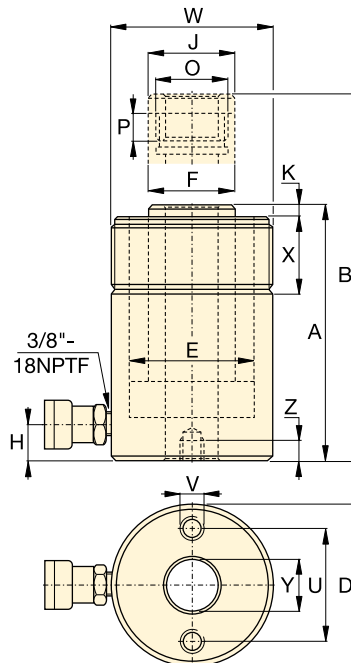

RCH202 to RCH1003 models

Base Mounting Hole Dimensions (mm)

Model Number	Bolt Circle U	Thread V	Thread Depth Z
RCH120	50,8	5/16" - 18 UNC	9,0
RCH121	-	-	-
RCH1211	-	-	-
RCH123	50,8	5/16" - 18 UNC	12,7
RCH202	82,6	3/8" - 16 UNC	9,4
RCH206	82,6	3/8" - 16 UNC	9,4
RCH302	92,2	3/8" - 16 UNC	14,0
RCH306	92,2	3/8" - 16 UNC	14,0
RCH603	130,3	1/2" - 13 UNC	14,0
RCH606	130,3	1/2" - 13 UNC	14,0
RCH1003	177,8	5/8" - 11 UNC	19,0

Coll. Height A (mm)	Ext. Height B (mm)	Outside Dia. D (mm)	Cyl. Bore Dia. E (mm)	Plgr. Dia. F (mm)	Cyl. Base to Advance Port H (mm)	Saddle Dia. J (mm)	Saddle Protrusion from Plgr. K (mm)	Plunger Internal Thread O	Plunger Thread Length P (mm)	Collar Thread W	Collar Thread Length X (mm)	Center Hole Dia. Y (mm)	Weight (kg)	Model Number
55	63	69	54,1	35,1	9	-	-	¾" - 16 UN	16	2¾" - 16	30	19,5	1,5	RCH120
120	162	69	54,1	35,1	25	-	-	-	-	2¾" - 16	30	19,5	2,8	RCH121 *
120	162	69	54,1	35,1	25	-	-	¾" - 16 UN	16	2¾" - 16	30	19,5	2,8	RCH1211
184	260	69	54,1	35,1	25	-	-	-	-	2¾" - 16	30	19,5	4,4	RCH123
162	211	98	73,1	54,1	19	54	9,7	1 9/16" - 16 UN	19	3 7/8" - 12	38	26,9	7,7	RCH202 *
306	461	98	73,1	54,1	25	54	9,7	1 9/16" - 16 UN	19	3 7/8" - 12	38	26,9	14,1	RCH206
178	242	114	88,9	63,5	21	63	9,0	1 13/16" - 16 UN	22	4 1/2" - 12	42	33,3	10,9	RCH302 *
330	485	114	88,9	63,5	25	63	9,0	1 13/16" - 16 UN	22	4 1/2" - 12	42	33,3	21,8	RCH306
247	323	159	123,9	91,9	31	91	12,0	2 3/4" - 16 UN	19	6 1/4" - 12	48	53,8	28,1	RCH603 *
323	476	159	123,9	91,9	31	91	12,0	2 3/4" - 16 UN	19	6 1/4" - 12	48	53,8	35,4	RCH606
254	330	212	165,1	127,0	38	126	12,0	4" - 16 UN	25	8 3/8" - 12	60	79,0	63,0	RCH1003*

▼ Shown from left to right: RRH3010, RRH1001, RRH6010



- Relief valves prevent damage in case of over-pressurisation
- Baked enamel finish for increased corrosion resistance
- Collar threads enable easy fixturing (except RRH1001 and RRH1508)
- Double-acting version for fast retraction
- Nickel-plated, floating center tube increases product life
- Hollow plunger allows for both pull and push forces
- CR400 coupler and dust cap included on all models
- Plunger wiper reduces contamination, extending cylinder life.

Versatility in Testing, Maintenance and Tensioning Applications



Ultra-Lightweight Aluminium Cylinders

If you need a higher cylinder capacity-to-weight-ratio the lightweight **RRH-Series** are the perfect choice.

Page: 18



Gauges

Minimize the risk of overloading and ensure long, dependable service from your equipment. Refer to the System Components Section for a full range of gauges.

Page: 127



Saddles

All RRH-Series cylinders are equipped with smooth saddles. See table at next page for optional threaded saddles and all dimensional information.

Page: 37

▼ Double-acting hollow plunger cylinders are applied for bridge launching systems.



Cylinder Capacity	Stroke	Model Number	Max. Cylinder Capacity (kN)		Cylinder Effective Area (cm ²)		Oil Capacity (cm ³)	
			Advance	Retract	Advance	Retract	Advance	Retract
30	178	RRH307	326	213	46,6	30,4	829	541
	258	RRH3010	326	213	46,6	30,4	1202	784
60	89	RRH603	576	380	82,3	54,2	733	482
	166	RRH606	576	380	82,3	54,2	1366	900
	257	RRH6010	576	380	82,3	54,2	2115	1393
95	38	RRH1001	931	612	133,0	87,4	505	333
	76	RRH1003	931	612	133,0	87,4	1011	666
	153	RRH1006	931	612	133,0	87,4	2035	1337
	257	RRH10010	931	612	133,0	87,4	3420	2246
145	203	RRH1508	1429	718	204,1	102,6	4144	2083

Double-Acting, Hollow Plunger Cylinders



Hoses

Enerpac offers a complete line of high quality hydraulic hoses. To ensure the integrity of your system, specify only Enerpac hydraulic hoses.

Page: 128

Optional Threaded Hollow Saddles						
Saddle Type	Cylinder Model Number	Saddle Model Nr.	Saddle Dimensions (mm)			
			A	B	C	
Threaded Hollow	RRH307, 3010	HP3015	63	1 1/4" - 7	9	
	RRH603, 606, 6010	HP5016	91	1 5/8" - 5 1/2	12	
	RRH1001, 1003, RRH1006, 10010	HP10016	126	2 1/2" - 8	13	

Smooth hollow saddles are standard on all RRH-models.

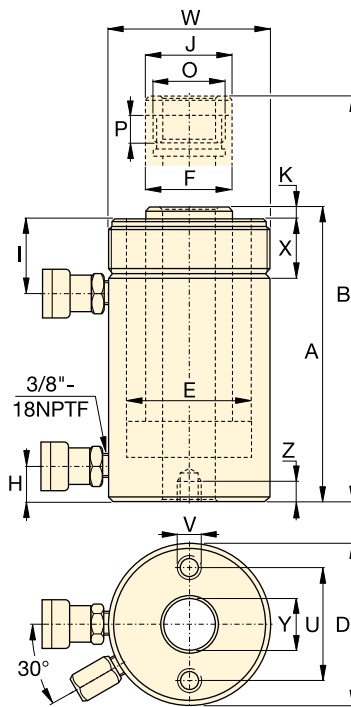

RRH Series

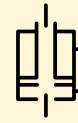

Capacity:

30 - 145 ton

Stroke:

38 - 258 mm

Center Hole Diameter:

33,3 - 79,2 mm

Maximum Operating Pressure:

700 bar



Pump Selection

A double-acting cylinder must be powered by a pump with a 4-way valve.

Page: 121

Base Mounting Hole Dimensions (mm)

Model Number	Bolt Circle U	Thread V	Thread Depth Z
RRH3010	92,2	3/8" - 16 UNC	15,7
RRH603	130,0	1/2" - 13 UNC	14,0
RRH606	130,0	1/2" - 13 UNC	14,0
RRH6010	130,0	1/2" - 13 UNC	14,0
RRH1001	177,8	5/8" - 11 UNC	19,0
RRH1003	177,8	5/8" - 11 UNC	19,0
RRH1006	177,8	5/8" - 11 UNC	19,0
RRH10010	177,8	5/8" - 11 UNC	19,0
RRH1508	213,4	5/8" - 11 UNC	23,0

Coll. Height A (mm)	Ext. Height B (mm)	Out. Dia. D (mm)	Cyl. Bore Dia. E (mm)	Plgr. Dia. F (mm)	Cyl. Base to Adv. Port H (mm)	Cyl. Top to Return Port I (mm)	Saddle Dia. J (mm)	Saddle Protr. fr. Plgr. K (mm)	Thread O	Plunger Thread Length P (mm)	Collar Thread W	Collar Thread Length X (mm)	Center Hole Dia. Y (mm)	Weight (kg)	Model Number
330	508	114	88,9	63,5	25	60	63	9	1 13/16" - 16	22	4 1/2" - 12	42	33,3	21	RRH307
431	689	114	88,9	63,5	25	60	63	9	1 13/16" - 16	22	4 1/2" - 12	42	33,3	27	RRH3010
247	336	159	123,9	91,9	31	66	91	12	2 3/4" - 16	19	6 1/4" - 12	48	53,8	28	RRH603
323	489	159	123,9	91,9	31	66	91	12	2 3/4" - 16	19	6 1/4" - 12	48	53,8	35	RRH606
438	695	159	123,9	91,9	31	66	91	12	2 3/4" - 16	19	6 1/4" - 12	48	53,8	45	RRH6010
165	203	212	165,1	127,0	38	44	126	12	4" - 16	25	-	-	79,2	33	RRH1001
254	330	212	165,1	127,0	38	85	126	12	4" - 16	25	8 3/8" - 12	60	79,2	61	RRH1003
342	495	212	165,1	127,0	38	85	126	12	4" - 16	25	8 3/8" - 12	60	79,2	79	RRH1006
460	717	212	165,1	127,0	38	85	126	12	4" - 16	25	8 3/8" - 12	60	79,2	106	RRH10010
349	552	247	190,5	152,4	38	60	127	4	4 1/4" - 12	25	-	-	79,2	111	RRH1508

▼ Shown from left to right: BRD2510, BRD96, BRD256, BRD41, BRD166



High Precision and High Cycle Performance



Speed Chart

See the Enerpac Cylinder Speed Chart in our 'Yellow Pages' to determine your approximate cylinder speed.

Page: **415**

- Designed for long life, the best choice for production applications
- Unique mounting configurations simplify fixturing
- Baked enamel finish for increased corrosion resistance
- Double-acting operation develops force in both directions, providing maximum versatility
- Plunger wiper reduces contamination, extending cylinder life
- Imperial models (RD-series) available on request.

▼ Clamping application using Enerpac BRD cylinders (with clevis eye attachments on both ends) for their high pressure capability and mounting flexibility.



Cylinder Capacity (ton)	Stroke (mm)	Model Number	Max. Cylinder Capacity (kN)		Cylinder Effective Area (cm ²)		Oil Capacity (cm ³)		Coll. Height A (mm)	Extended Height B (mm)	Body Length C (mm)	Outside Dia. D (mm)	Cylinder Bore Dia. E (mm)	Plunger Dia. F (mm)
			Advance	Retract	Advance	Retract	Advance	Retract						
4	28	BRD41	35	16	5,1	2,2	14	6	186	214	162	50	25,4	19,0
	79	BRD43	35	16	5,1	2,2	40	17	237	316	213	50	25,4	19,0
	155	BRD46	35	16	5,1	2,2	79	34	313	468	289	50	25,4	19,0
8	28	BRD91	80	44	11,4	6,3	32	18	223	251	198	63,5	38,1	25,4
	79	BRD93	80	44	11,4	6,3	90	50	274	353	249	63,5	38,1	25,4
	155	BRD96	80	44	11,4	6,3	177	98	350	505	325	63,5	38,1	25,4
	257	BRD910	80	44	11,4	6,3	293	162	452	709	427	63,5	38,1	25,4
15	159	BRD166	142	77	20,3	10,6	323	169	389	548	359	80	50,8	35,0
	260	BRD1610	142	77	20,3	10,6	528	276	491	751	461	80	50,8	35,0
23	159	BRD256	222	98	31,7	13,7	504	218	424	583	397	92	63,5	47,8
	260	BRD2510	222	98	31,7	13,7	824	356	526	786	499	92	63,5	47,8

Double-Acting, Precision Production Cylinders

▼ BRD CYLINDER ATTACHMENTS

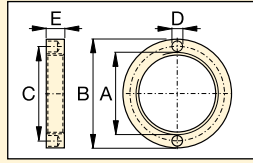

Retainer Nut
For locking foot or flange mountings. Tightens onto cylinder collar threads (Included with foot and flange mounting kits).

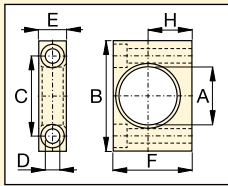

Foot Mounting
Mounts onto cylinder collar.

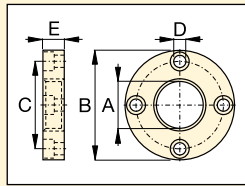

Flange Mounting
Mounts onto cylinder collar.

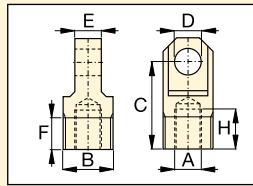

Clevis Eye
Threads onto plunger or into cylinder base.

Model Number	BRD-Cyl. (ton)	Dimensions (mm)						
		A	B	C	D	E	F	H
Foot Mounting with Retainer Nut								
BAD141	4	42,1	80	58,0	10,5	20,0	57,0	31,8
BAD171	8	56,1	105	78,0	13,5	25,0	82,5	44,5
BAD181	15	70,1	127	95,2	20,0	35,0	100,0	52,4
BAD191	23	85,1	159	117,5	26,5	45,0	125,0	63,5
Flange Mounting with Retainer Nut								
BAD142	4	42,1	98,4	78,6	11,0	19,0	-	-
BAD172	8	56,1	121	98,4	11,0	25,4	-	-
BAD182	15	70,1	143	115,9	14,0	35,0	-	-
BAD192	23	85,1	165	135,7	17,0	44,5	-	-
Retainer Nut								
BAD143	4	M42 x 1,5	57	49,5	6,3	9,5	-	-
BAD173	8	M56 x 2	75	65,5	6,7	12,7	-	-
BAD183	15	M70 x 2	92	81,0	6,7	19,0	-	-
BAD193	23	M85 x 2	108	96,5	6,7	25,4	-	-
Clevis Eye (See chart below for mounting dimensions L, L1 and M)								
BAD150	4	M16 x 1,5	M30 x 1,5	52,4	16,0	15,9	19,1	23,8
BAD151	8	M22 x 1,5	M42 x 1,5	57,1	20,0	25,4	25,4	23,8
BAD152	15	M30 x 1,5	M56 x 2	77,8	25,0	31,8	25,4	30,2
BAD153	23	M42 x 1,5	M70 x 2	77,8	32,0	38,2	25,4	27,0

BRD Series



Capacity:
4 - 23 ton

Stroke:
28 - 260 mm

Maximum Operating Pressure:
700 bar

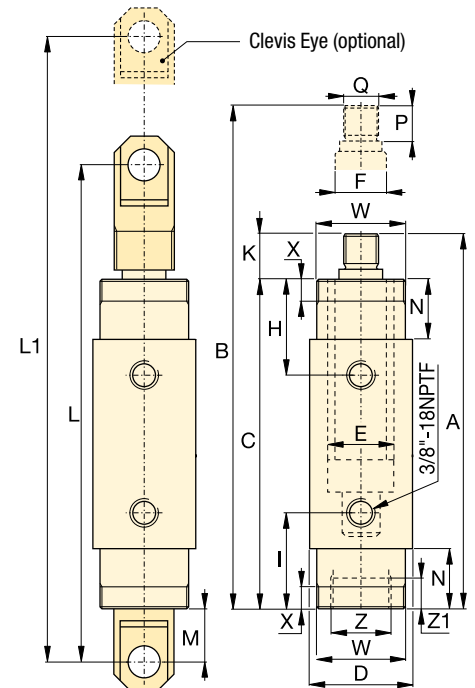

	Top to Retract Port H (mm)	Bottom to Advance Port I (mm)	Plunger Protrusion K (mm)	Clevis Eye Mounting Dimensions			Neck Length N (mm)	Plunger Thread Length P (mm)	Plunger External Thread Q (mm)	Cylinder Mounting Dimensions (mm)				Model Number	
				L (mm)	L1 (mm)	M (mm)				Collar Thread W	Collar Thread Length X	Internal Base Thread Z	Int. Base Thread Length Z1		
	47	47	24	258	286	41	29	22	M16 x 1,5	M42 x 1,5	11	M30 x 1,5	9	2,0	BRD41
	47	47	24	308	387	41	29	22	M16 x 1,5	M42 x 1,5	11	M30 x 1,5	9	2,6	BRD43
	47	47	24	385	540	41	29	22	M16 x 1,5	M42 x 1,5	11	M30 x 1,5	9	3,6	BRD46
	57	57	25	295	323	38	38	22	M22 x 1,5	M56 x 2	14	M42 x 1,5	14	3,0	BRD91
	57	57	25	346	425	38	38	22	M22 x 1,5	M56 x 2	14	M42 x 1,5	14	4,2	BRD93
	57	57	25	422	577	38	38	22	M22 x 1,5	M56 x 2	14	M42 x 1,5	14	5,6	BRD96
	57	57	25	524	781	38	38	22	M22 x 1,5	M56 x 2	14	M42 x 1,5	14	7,3	BRD910
	73	73	30	492	651	52	54	28	M30 x 1,5	M70 x 2	22	M56 x 2	24	10,2	BRD166
	73	73	30	593	853	52	54	28	M30 x 1,5	M70 x 2	22	M56 x 2	24	14,5	BRD1610
	89	89	27	524	683	53	70	25	M42 x 1,5	M85 x 2	29	M70 x 2	26	16,0	BRD256
	89	89	27	626	886	53	70	25	M42 x 1,5	M85 x 2	29	M70 x 2	26	20,3	BRD2510

RR-Series, Double-Acting Cylinders

ENERPAC 

▼ Shown from left to right: RR10013, RR1502, RR20013, RR1010, RR7513



- Collar threads, plunger threads and base mounting holes for easy fixturing (on most models)
- Baked enamel finish for increased corrosion resistance
- Removable hardened saddles protect plunger during lifting and pressing
- Built-in safety valve prevents accidental over-pressurization
- CR400 couplers and dust caps included on all models
- Plunger wiper reduces contamination, extending cylinder life.

▼ A lateral bridge slide method was utilized to slide the new bridge into position. Two RR-Series double acting hydraulic cylinders with ZU4-Series electric pumps were used to push the bridge into position over PTFE sliding elements.



Most Versatile Performers

Rugged enough for the toughest job site uses and precision designed for high-cycle industrial uses.



Optional Snap-in Saddles

Optional snap-in saddles for RR-Series double-acting cylinders up to 75 ton.

Page: 41



Optimum Performance

Enerpac's range of Z-Class electric pumps, fitted with manual or solenoid operated 4-way valves, offer optimum combinations with RR-Series cylinders.

Page: 96

▼ RR-cylinders provide power and precision in a special hydraulic press.



Double-Acting Long Stroke Cylinders



Pump Selection

A double-acting cylinder must be powered by a pump with a 4-way valve.

Page: 75

▼ QUICK SELECTION CHART

For complete technical information see next page.

Cylinder Capacity ton (kN)	Stroke (mm)	Model Number	Cylinder Effective Area (cm ²)		Oil Capacity (cm ³)		Coll. Height (mm)
			Push	Pull	Push	Pull	
10 (101)	254	RR1010	14,5	4,8	368	122	409
	305	RR1012	14,5	4,8	442	147	457
30 (295)	209	RR308	42,1	19,1	879	400	394
	368	RR3014	42,1	19,1	1549	703	549
50 (498)	156	RR506	71,2	21,5	1111	335	331
	334	RR5013	71,2	21,5	2378	718	509
	511	RR5020	71,2	21,5	3638	1099	733
75 (718)	156	RR756	102,6	31,4	1601	490	347
	333	RR7513	102,6	31,4	3417	1046	525
95 (933)	168	RR1006	133,3	62,2	2238	1045	357
	333	RR10013	133,3	62,2	4439	2071	524
	460	RR10018	133,3	62,2	6132	2861	687
140 (1386)	57	RR1502	198,1	95,4	1129	544	183
	156	RR1506	198,1	95,4	3090	1488	385
	333	RR15013	198,1	95,4	6597	3177	582
	815	RR15032	198,1	95,4	16.145	7775	1116
200 (1995)	152	RR2006	285,0	145,3	4332	2209	430
	330	RR20013	285,0	145,3	9405	4795	608
	457	RR20018	285,0	145,3	13025	6640	765
	610	RR20024	285,0	145,3	17.385	8863	917
	914	RR20036	285,0	145,3	26.049	13.280	1222
1219	RR20048	285,0	145,3	34.741	17.712	1527	
325 (3201)	153	RR3006	457,3	243,2	6997	3721	485
	305	RR30012	457,3	243,2	13947	7418	638
	457	RR30018	457,3	243,2	20.889	11.114	790
	609	RR30024	457,3	243,2	27.850	14.811	943
	915	RR30036	457,3	243,2	41.843	22.253	1247
	1219	RR30048	457,3	243,2	55745	29646	1552
440 (4292)	152	RR4006	613,1	328,1	9319	4987	538
	305	RR40012	613,1	328,1	18.700	10.007	690
	457	RR40018	613,1	328,1	28.018	14.995	843
	610	RR40024	613,1	328,1	37.400	20.014	995
	914	RR40036	613,1	328,1	56.037	29.988	1300
	1219	RR40048	613,1	328,1	74.737	39.996	1605
520 (5108)	153	RR5006	729,7	405,4	11.164	6203	577
	305	RR50012	729,7	405,4	22.256	12.365	730
	457	RR50018	729,7	405,4	33.347	18.526	882
	609	RR50024	729,7	405,4	44.440	24.689	1035
	915	RR50036	729,7	405,4	66.768	36.973	1339
	1219	RR50048	729,7	405,4	88.951	49.418	1644

RR Series



Capacity:

10 - 520 ton

Stroke:

57 - 1219 mm

Maximum Operating Pressure:

700 bar

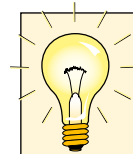

Enerpac HCR-Series

If your application does not require high cycle, Enerpac **HCR-Series** cylinders may be the right alternative.

Page: 52



Speed Chart

See the Enerpac Cylinder Speed Chart in our 'Yellow Pages' to determine your approximate cylinder speed.

Page: 415



Optional Snap-in Saddles

Optional snap-in saddles for RR-Series double-acting cylinders:

Saddle Type	Cylinder Model	Saddle Model Number
Flat	RR10	A102F
	RR10	CATS12
Tilt	RR30	CATS52
	RR50	CATS100
	RR75	CATS100

Standard Saddles:

Grooved	Cylinder Model	Saddle Model Number
Grooved	RR10	A102G
	RR30	A252G

For additional information on saddles:

Page: 10

RR-Series, Double-Acting Cylinders

ENERPAC 

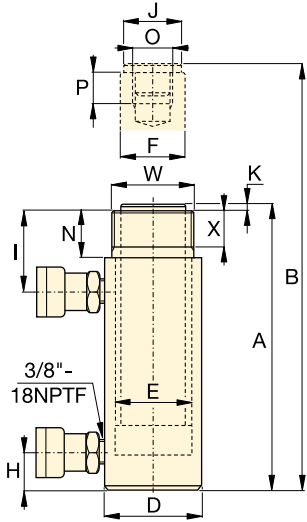

RR1010 - RR3014

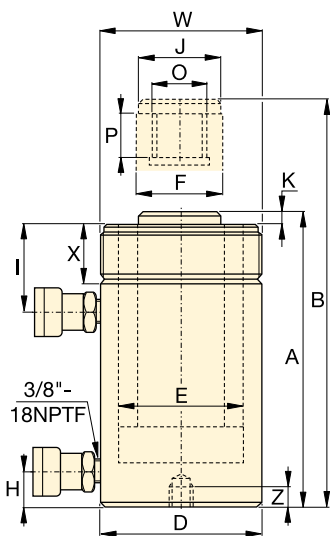

RR506 - RR50048

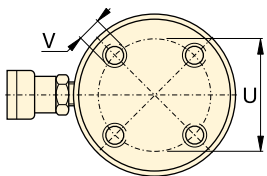

RR1006 - RR30048

No mounting holes on:
RR506, 5013
RR756, 7513
RR1502, 15032

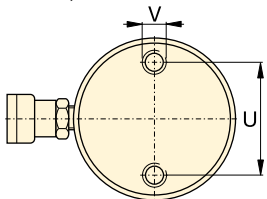

RR4006 - RR50048

Base mounting hole location is for reference only, as it is affected by assembly.



Cylinder retract capacity for certain RR cylinders may be less than theoretical values, as a result of reduced relief valve pressure settings:

RR308/3014: 275 bar
RR506/5013/5020: 480 bar
RR756/7513: 495 bar

◀ For full features see previous page.

Cylinder Capacity	Stroke (mm)	Model Number	Max. Cylinder Capacity (kN)		Cylinder Effective Area (cm ²)		Oil Capacity (cm ³)		Coll. Height	Ext. Height	Outside Dia.
			Push	Pull	Push	Pull	Push	Pull	A (mm)	B (mm)	D (mm)
10	254	RR1010 *	101	33	14,5	4,8	368	122	409	663	73
	305	RR1012 *	101	33	14,5	4,8	442	147	457	762	73
30	209	RR308 *	295	53	42,1	19,1	879	400	394	603	101
	368	RR3014 *	295	53	42,1	19,1	1549	703	549	917	101
50	156	RR506	498	103	71,2	21,5	1111	335	331	487	127
	334	RR5013	498	103	71,2	21,5	2378	718	509	843	127
	511	RR5020	498	103	71,2	21,5	3638	1099	733	1244	127
75	156	RR756	718	156	102,6	31,4	1601	490	347	503	146
	333	RR7513	718	156	102,6	31,4	3417	1046	525	858	146
95	168	RR1006	933	435	133,3	62,2	2238	1045	357	525	177
	333	RR10013	933	435	133,3	62,2	4439	2071	524	857	177
	460	RR10018	933	435	133,3	62,2	6132	2861	687	1147	177
140	57	RR1502	1386	668	198,1	95,4	1129	544	183	240	203
	156	RR1506	1386	668	198,1	95,4	3090	1488	385	541	203
	333	RR15013	1386	668	198,1	95,4	6597	3177	582	915	203
	815	RR15032	1386	668	198,1	95,4	16.145	7775	1116	1931	203
200	152	RR2006	1995	1017	285,0	145,3	4332	2209	430	582	247
	330	RR20013	1995	1017	285,0	145,3	9405	4795	608	938	247
	457	RR20018	1995	1017	285,0	145,3	13.025	6640	765	1222	247
	610	RR20024	1995	1017	285,0	145,3	17.385	8863	917	1527	247
	914	RR20036	1995	1017	285,0	145,3	26.049	13.280	1222	2136	247
	1219	RR20048	1995	1017	285,0	145,3	34.741	17.712	1527	2746	247
325	153	RR3006	3201	1703	457,3	243,2	6997	3721	485	638	311
	305	RR30012	3201	1703	457,3	243,2	13.947	7418	638	943	311
	457	RR30018	3201	1703	457,3	243,2	20.889	11.114	790	1247	311
	609	RR30024	3201	1703	457,3	243,2	27.850	14.811	943	1552	311
	915	RR30036	3201	1703	457,3	243,2	41.843	22.253	1247	2162	311
	1219	RR30048	3201	1703	457,3	243,2	55.745	29.646	1552	2771	311
440	152	RR4006	4292	2297	613,1	328,1	9319	4987	538	690	358
	305	RR40012	4292	2297	613,1	328,1	18.700	10.007	690	995	358
	457	RR40018	4292	2297	613,1	328,1	28.018	14.995	843	1300	358
	610	RR40024	4292	2297	613,1	328,1	37.400	20.014	995	1605	358
	914	RR40036	4292	2297	613,1	328,1	56.037	29.988	1300	2214	358
	1219	RR40048	4292	2297	613,1	328,1	74.737	39.996	1605	2824	358
520	153	RR5006	5108	2838	729,7	405,4	11164	6203	577	730	397
	305	RR50012	5108	2838	729,7	405,4	22.256	12.365	730	1035	397
	457	RR50018	5108	2838	729,7	405,4	33.347	18.526	882	1339	397
	609	RR50024	5108	2838	729,7	405,4	44.440	24.689	1035	1644	397
	915	RR50036	5108	2838	729,7	405,4	66.768	36.973	1339	2254	397
	1219	RR50048	5108	2838	729,7	405,4	88.951	49.418	1644	2863	397

* For RR1010 and RR1012: N = 32 mm; for RR308 and RR3014: N = 55 mm.

Double-Acting Long Stroke Cylinders

Capacity:

10 - 520 ton

Stroke:

57 - 1219 mm

Maximum Operating Pressure:

700 bar

**RR
Series**



Cyl. Bore Dia. E (mm)	Plgr. Dia. F (mm)	Base to Adv. Port H (mm)	Top to Ret. Port I (mm)	Saddle Dia. J (mm)	Saddle Protr. fr. Plgr. K (mm)	Plunger Internal Thread O	Plunger Thread Length P (mm)	Base Mounting Holes			Collar Thread W	Collar Thread Length X (mm)	Model Number	
								Bolt Circle U (mm)	Thread V	Thread Depth Z (mm)				
42,9	34,9	36	57	35	6	1" - 8	25	-	-	-	2 1/4" - 14	26	12	RR1010*
42,9	34,9	36	57	35	6	1" - 8	25	-	-	-	2 1/4" - 14	26	14	RR1012*
73,2	54,1	39	81	50	10	1 1/2" - 16	25	-	-	-	3 5/16" - 12	49	18	RR308*
73,2	54,1	39	81	50	10	1 1/2" - 16	25	-	-	-	3 5/16" - 12	49	29	RR3014*
95,2	79,5	28	76	71	2	1" - 12	25	-	-	-	5" - 12	44	30	RR506
95,2	79,5	28	76	71	2	1" - 12	25	-	-	-	5" - 12	44	52	RR5013
95,2	79,5	57	76	71	2	1" - 12	25	76	1/2" - 13	25	5" - 12	44	68	RR5020
114,3	95,2	30	76	71	6	1" - 12	28	-	-	-	5 3/4" - 12	50	41	RR756
114,3	95,2	30	81	71	6	1" - 12	28	-	-	-	5 3/4" - 12	50	68	RR7513
130,3	95,2	38	71	76	3	1 3/4" - 12	35	139	3/4" - 10	25	6 7/8" - 12	50	61	RR1006
130,3	95,2	38	71	76	3	1 3/4" - 12	35	139	3/4" - 10	25	6 7/8" - 12	50	93	RR10013
130,3	95,2	41	92	76	3	1 3/4" - 12	35	139	3/4" - 10	25	6 7/8" - 12	50	117	RR10018
158,8	114,3	22	66	95	19	-	-	-	-	-	-	-	49	RR1502
158,8	114,3	49	84	114	19	3 3/8" - 16	35	158	3/4" - 16	28	8" - 12	55	93	RR1506
158,8	114,3	49	84	114	19	3 3/8" - 16	35	158	3/4" - 16	28	8" - 12	55	124	RR15013
158,8	114,3	76	88	114	19	3 3/8" - 16	35	-	-	-	8" - 12	55	238	RR15032
190,5	133,4	57	96	133	22	-	-	127	1" - 8	25	-	-	147	RR2006
190,5	133,4	57	96	133	22	2 1/2" - 12	63	127	1" - 8	25	9 3/4" - 12	54	199	RR20013
190,5	133,4	85	101	133	22	2 1/2" - 12	63	127	1" - 8	25	9 3/4" - 12	54	204	RR20018
190,5	133,4	85	101	133	22	2 1/2" - 12	63	127	1" - 8	25	9 3/4" - 12	54	279	RR20024
190,5	133,4	85	101	133	22	2 1/2" - 12	63	127	1" - 8	25	9 3/4" - 12	54	383	RR20036
190,5	133,4	85	101	133	22	2 1/2" - 12	63	127	1" - 8	25	9 3/4" - 12	54	483	RR20048
241,3	165,1	88	114	165	28	2 1/2" - 12	82	158	1 1/4" - 7	44	12 1/4" - 12	58	200	RR3006
241,3	165,1	88	114	165	28	2 1/2" - 12	82	158	1 1/4" - 7	44	12 1/4" - 12	58	312	RR30012
241,3	165,1	88	114	165	28	2 1/2" - 12	82	158	1 1/4" - 7	44	12 1/4" - 12	58	385	RR30018
241,3	165,1	88	114	165	28	2 1/2" - 12	82	158	1 1/4" - 7	44	12 1/4" - 12	58	469	RR30024
241,3	165,1	88	114	165	28	2 1/2" - 12	82	158	1 1/4" - 7	44	12 1/4" - 12	58	628	RR30036
241,3	165,1	88	114	165	28	2 1/2" - 12	82	158	1 1/4" - 7	44	12 1/4" - 12	58	780	RR30048
279,4	190,5	108	133	190	28	3" - 12	95	203	1 1/2" - 6	50	14 1/8" - 8	65	303	RR4006
279,4	190,5	108	133	190	28	3" - 12	95	203	1 1/2" - 6	50	14 1/8" - 8	65	399	RR40012
279,4	190,5	108	133	190	28	3" - 12	95	203	1 1/2" - 6	50	14 1/8" - 8	65	453	RR40018
279,4	190,5	108	133	190	28	3" - 12	95	203	1 1/2" - 6	50	14 1/8" - 8	65	597	RR40024
279,4	190,5	108	133	190	28	3" - 12	95	203	1 1/2" - 6	50	14 1/8" - 8	65	792	RR40036
279,4	190,5	108	133	190	28	3" - 12	95	203	1 1/2" - 6	50	14 1/8" - 8	65	980	RR40048
304,8	203,2	120	152	203	28	3 1/4" - 12	108	203	1 3/4" - 5	57	15 5/8" - 8	79	432	RR5006
304,8	203,2	120	152	203	28	3 1/4" - 12	108	203	1 3/4" - 5	57	15 5/8" - 8	79	589	RR50012
304,8	203,2	120	152	203	28	3 1/4" - 12	108	203	1 3/4" - 5	57	15 5/8" - 8	79	680	RR50018
304,8	203,2	120	152	203	28	3 1/4" - 12	108	203	1 3/4" - 5	57	15 5/8" - 8	79	816	RR50024
304,8	203,2	120	152	203	28	3 1/4" - 12	108	203	1 3/4" - 5	57	15 5/8" - 8	79	1002	RR50036
304,8	203,2	120	152	203	28	3 1/4" - 12	108	203	1 3/4" - 5	57	15 5/8" - 8	79	1224	RR50048

▼ HCL2006, HCG2002, HCR2006



Reaching the Summit Edition:

- Nitrocarburized hardened surfaces offers improved protection against side-load scoring and cyclic wear
- Weather protected, inside and out
- Low-friction locking rings spin easy, save time and effort ¹⁾
- State of the art bearing materials reduce wear and avoid bore damage even in high side-load conditions.

Low wear, high pressure seals

- Improved seal design and material selection increases seal performance even in harsh conditions
- Low friction for faster retraction, longer life.

Versatile

- Over 220 models in 5 configurations ¹⁾
- Certified lifting eyes, base mounting holes and collar threads are included for secure handling and cylinder mounting ¹⁾

¹⁾ See specific models technical data for more information.

Highest Level of Durability



The Summit Edition

Innovation is at the heart of the new Summit Edition cylinders, delivering the high quality construction you expect from Enerpac. The design and durability add safety and reliability to your job.

- Plunger support bearing adds support for eccentric loads ²⁾
- Nitrocarburization surface treatment for improved wear resistance and corrosion protection
- Low wear, high pressure seals provide longer service life.

²⁾ Eccentric load (or "side-load") is inevitable in heavy lifting. Our unique Summit Edition features provide the ultimate protection against side-load. Increased bearing surface maintains stability and nitrocarburization treatment prevents scoring on the inside of the cylinder. Side-load poses a real problem.... our new cylinder features are the solution!

▼ Bridge lifting and launching system. The load is balanced on groups of lock nut cylinders. The hydraulic movements are synchronised using the Enerpac PLC-controlled synchronous lift system.





High Tonnage Cylinders

The Enerpac High Tonnage Cylinders are particularly suitable for (multipoint) lifting applications.

HCG, HCR, HCL-Series Cylinders

- 50 - 1000 ton lifting capacity
- 50 - 300 mm stroke

HCG-Series - single-acting

- gravity return
- stop ring to prevent plunger blow-out
- designed to withstand up to 10% side-load of maximum capacity.

HCR-Series - double-acting

- hydraulic advance and retract for controlled movement
- designed to withstand up to 10% side-load of maximum capacity.

HCL-Series - lock nut, single-acting

- gravity return
- lock nut for mechanical load holding
- overflow port to prevent plunger blow out
- designed to withstand 10% side-load up to 90% of maximum stroke.

HCRL-Series - lock nut, double-acting

- hydraulic advance and retract
- designed to withstand up to 10% side-load of maximum capacity
- integrated tilt saddle
- lock nut for mechanical load holding
- 50 - 300 ton lifting capacity
- 150 - 300 mm stroke

LPL-Series - lock nut, low height, single-acting (see page 24)

- 60 - 500 ton lifting capacity;
- 45 - 50 mm lifting stroke
- integrated tilt saddle
- gravity return
- lock nut for mechanical load holding
- 5-10% side-load of maximum capacity.

In combination with our state of the art power packs, you will have a world class hydraulic system to perform the most challenging lifting jobs in a safe and professional manner. See **page 75** for more information on our pump offering.

Page: 46

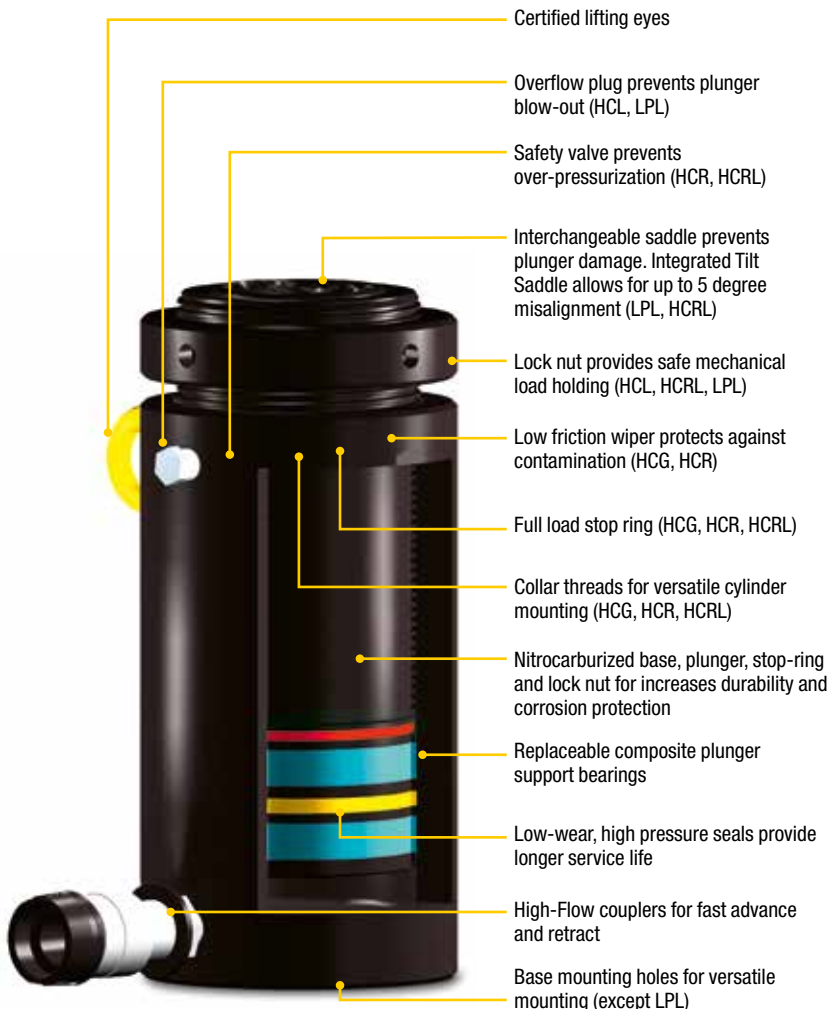

HCG HCR HCL HCRL Series



Capacity:

50 - 1000 ton

Stroke:

50 - 300 mm

Maximum Operating Pressure:

700 bar



Assisted Return Pumps

Enerpac HCG, HCL and LPL-Series cylinders are hydraulic advance and gravity return. To improve productivity and plunger retraction Enerpac offers assisted return on ZU4 and ZE-Series pumps featuring **Enerpac Venturi valve technology**, specifically to facilitate the faster return of single-acting, spring and gravity return cylinders. See enerpac.com for details.

Page: 100



Split-Flow Pumps

SFP-Series pumps with multiple outlets with equal oil flow. For lifting and lowering applications on multiple points these pumps are a far better alternative than using separately operated pumps.

Page: 344



Synchronous Lifting Systems

EVO-Series pumps the multi-functional lifting system and multiple lift point capabilities.

Page: 350



QUICK SELECTION

Cylinder Capacity ton	Stroke (mm)	Maximum Cylinder Capacity at 700 bar ton (kN)	HCG-Series		HCR-Series		HCL-Series		HCRL-Series *	
			Model Number Single-Acting <i>Page: 48</i>	Collapsed Height (mm)	Model Number Double-Acting <i>Page: 52</i>	Collapsed Height (mm)	Model Number Single-Acting With Lock Nut <i>Page: 56</i>	Collapsed Height (mm)	Model Number Double-Acting With Lock Nut <i>Page: 60</i>	Collapsed Height (mm)
50	50	56 (550)	HCG502	183	HCR502	183	HCL502	164	—	—
	100		HCG504	233	HCR504	233	HCL504	214	—	—
	150		HCG506	283	HCR506	283	HCL506	264	HCRL506	310
	200		HCG508	346	HCR508	346	HCL508	314	HCRL508	377
	250		HCG5010	396	HCR5010	396	HCL5010	364	HCRL5010	427
	300		HCG5012	446	HCR5012	446	HCL5012	414	HCRL5012	477
100	50	102 (1002)	HCG1002	202	HCR1002	202	HCL1002	187	—	—
	100		HCG1004	252	HCR1004	252	HCL1004	237	—	—
	150		HCG1006	302	HCR1006	302	HCL1006	287	HCRL1006	346
	200		HCG1008	379	HCR1008	379	HCL1008	337	HCRL1008	421
	250		HCG10010	429	HCR10010	429	HCL10010	387	HCRL10010	471
	300		HCG10012	479	HCR10012	479	HCL10012	437	HCRL10012	521
150	50	153 (1497)	HCG1502	220	HCR1502	220	HCL1502	209	—	—
	100		HCG1504	270	HCR1504	270	HCL1504	259	—	—
	150		HCG1506	320	HCR1506	320	HCL1506	309	HCRL1506	359
	200		HCG1508	397	HCR1508	397	HCL1508	359	HCRL1508	434
	250		HCG15010	447	HCR15010	447	HCL15010	409	HCRL15010	484
	300		HCG15012	497	HCR15012	497	HCL15012	459	HCRL15012	534
200	50	202 (1985)	HCG2002	231	HCR2002	231	HCL2002	238	—	—
	100		HCG2004	281	HCR2004	281	HCL2004	288	—	—
	150		HCG2006	331	HCR2006	331	HCL2006	338	HCRL2006	399
	200		HCG2008	408	HCR2008	408	HCL2008	388	HCRL2008	469
	250		HCG20010	458	HCR20010	458	HCL20010	438	HCRL20010	519
	300		HCG20012	508	HCR20012	508	HCL20012	488	HCRL20012	569
250	50	259 (2541)	HCG2502	241	HCR2502	241	HCL2502	249	—	—
	100		HCG2504	291	HCR2504	291	HCL2504	299	—	—
	150		HCG2506	341	HCR2506	341	HCL2506	349	HCRL2506	416
	200		HCG2508	431	HCR2508	431	HCL2508	399	HCRL2508	491
	250		HCG25010	481	HCR25010	481	HCL25010	449	HCRL25010	541
	300		HCG25012	531	HCR25012	531	HCL25012	499	HCRL25012	591
300	50	310 (3036)	HCG3002	296	HCR3002	296	HCL3002	278	—	—
	100		HCG3004	346	HCR3004	346	HCL3004	328	—	—
	150		HCG3006	396	HCR3006	396	HCL3006	378	HCRL3006	421
	200		HCG3008	446	HCR3008	446	HCL3008	428	HCRL3008	496
	250		HCG30010	496	HCR30010	496	HCL30010	478	HCRL30010	546
	300		HCG30012	546	HCR30012	546	HCL30012	528	HCRL30012	596

* See page 60 for HCRL-cylinder maximum capacity.

Enerpac High Tonnage Cylinders

Capacity:
50 - 1000 ton

Stroke:
50 - 300 mm

Maximum Operating Pressure:
700 bar

**HCG
HCR
HCL
HCRL
Series**



QUICK SELECTION

Cylinder Capacity ton	Stroke (mm)	Maximum Cylinder Capacity at 700 bar ton (kN)	HCG-Series		HCR-Series		HCL-Series	
			Model Number Single-Acting Page: 50	Collapsed Height (mm)	Model Number Double-Acting Page: 54	Collapsed Height (mm)	Model Number Single-Acting With Lock Nut Page: 58	Collapsed Height (mm)
400	50	409 (4008)	HCG4002	321	HCR4002	321	HCL4002	317
	100		HCG4004	371	HCR4004	371	HCL4004	367
	150		HCG4006	421	HCR4006	421	HCL4006	417
	200		HCG4008	471	HCR4008	471	HCL4008	467
	250		HCG40010	521	HCR40010	521	HCL40010	517
	300		HCG40012	571	HCR40012	571	HCL40012	567
500	50	522 (5114)	HCG5002	344	HCR5002	344	HCL5002	357
	100		HCG5004	394	HCR5004	394	HCL5004	407
	150		HCG5006	444	HCR5006	444	HCL5006	457
	200		HCG5008	494	HCR5008	494	HCL5008	507
	250		HCG50010	544	HCR50010	544	HCL50010	557
	300		HCG50012	594	HCR50012	594	HCL50012	607
600	50	611 (5987)	HCG6002	352	HCR6002	352	HCL6002	380
	100		HCG6004	402	HCR6004	402	HCL6004	430
	150		HCG6006	452	HCR6006	452	HCL6006	480
	200		HCG6008	502	HCR6008	502	HCL6008	530
	250		HCG60010	552	HCR60010	552	HCL60010	580
	300		HCG60012	602	HCR60012	602	HCL60012	630
800	50	831 (8149)	HCG8002	404	HCR8002	404	HCL8002	430
	100		HCG8004	454	HCR8004	454	HCL8004	480
	150		HCG8006	504	HCR8006	504	HCL8006	530
	200		HCG8008	554	HCR8008	554	HCL8008	580
	250		HCG80010	604	HCR80010	604	HCL80010	630
	300		HCG80012	654	HCR80012	654	HCL80012	680
1000	50	1085 (10.644)	HCG10002	442	HCR10002	442	HCL10002	484
	100		HCG10004	492	HCR10004	492	HCL10004	534
	150		HCG10006	542	HCR10006	542	HCL10006	584
	200		HCG10008	592	HCR10008	592	HCL10008	634
	250		HCG100010	642	HCR100010	642	HCL100010	684
	300		HCG100012	692	HCR100012	692	HCL100012	734

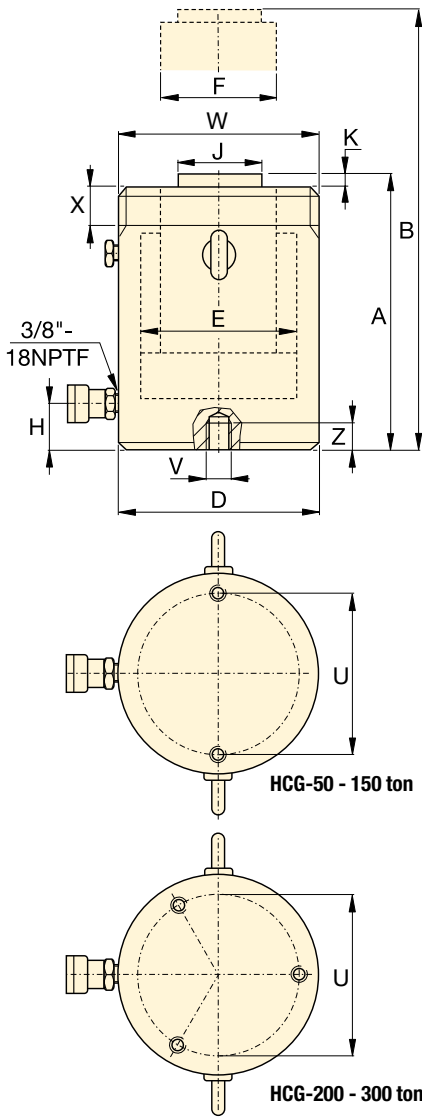

HCG-Series, Single-Acting, Gravity Return Cylinders

- Hardened surface resists side-loading and cyclic wear
- Designed to withstand 10% side-load of maximum capacity ¹⁾
- Stop ring to prevent plunger blow-out
- Weather protected, inside and out
- Upper and lower replaceable bearings enclose the cylinder plunger for support throughout the stroke
- Certified lifting eyes, base mounting holes and collar threads.
- Standard collar thread up to 250 ton models. Collar thread is optional on 300 ton models and higher.

SELECTION CHART 50 - 300 TON HCG-MODELS

For 400 - 1000 ton models, see pages 50-51.

For full product features see pages 44-45.

Cylinder Capacity	Stroke	Model Number	Maximum Cylinder Capacity at 700 bar ton (kN)	Cylinder Effective Area	Oil Capacity	Collapsed Height
ton	(mm)			(cm ²)	(cm ³)	A (mm)
50	50	HCG502	56 (550)	78,5	393	183
	100	HCG504			785	233
	150	HCG506 ¹⁾			1178	283
	200	HCG508			1571	346
	250	HCG5010			1963	396
	300	HCG5012 ¹⁾			2356	446
100	50	HCG1002	102 (1002)	143,1	716	202
	100	HCG1004			1431	252
	150	HCG1006			2147	302
	200	HCG1008			2863	379
	250	HCG10010			3578	429
	300	HCG10012			4294	479
150	50	HCG1502	153 (1497)	213,8	1069	220
	100	HCG1504			2138	270
	150	HCG1506			3207	320
	200	HCG1508			4276	397
	250	HCG15010			5346	447
	300	HCG15012			6415	497
200	50	HCG2002	202 (1985)	283,5	1418	231
	100	HCG2004			2835	281
	150	HCG2006			4253	331
	200	HCG2008			5671	408
	250	HCG20010			7088	458
	300	HCG20012			8506	508
250	50	HCG2502	259 (2541)	363,1	1815	241
	100	HCG2504			3631	291
	150	HCG2506			5446	341
	200	HCG2508			7261	431
	250	HCG25010			9076	481
	300	HCG25012			10.892	531
300	50	HCG3002	310 (3036)	433,7	2169	296
	100	HCG3004			4337	346
	150	HCG3006			6506	396
	200	HCG3008			8675	446
	250	HCG30010			10.843	496
	300	HCG30012			13.012	546

Collar Thread * (mm)		
Model / Capacity ton	Thread Size	Thread Length
	W	X
HCG50	M130 x 2	30
HCG100	M175 x 3	46
HCG150	M215 x 3	55
HCG200	M250 x 3	63
HCG250	M280 x 3	64
HCG300*	M305 x 3	73

* Standard collar thread up to 250 ton models. Collar thread is optional on 300 ton models and higher. For collar thread on cylinder add suffix "E002" to model number. **Example: HCG3006E002**
The collar thread length is designed for the full rated cylinder capacity.

Base Mounting Holes (mm)					
Model / Capacity ton	Bolt Circle	Thread Size	Minimum Thread Depth	Number of Holes	Angle from Coupler
	U	V	Z		
HCG50	105	M12 x 1,75	22	2	90°
HCG100	150	M12 x 1,75	22	2	90°
HCG150	185	M12 x 1,75	22	2	90°
HCG200	215	M12 x 1,75	22	3	60°
HCG250	245	M12 x 1,75	22	3	60°
HCG300	260	M16 x 2	25	3	60°

¹⁾ HCG506 and HCG5012: 7% side-load of maximum capacity.

Single-Acting, High Tonnage Cylinders

Capacity:
50 - 300 ton

Stroke:
50 - 300 mm

Maximum Operating Pressure:
700 bar

HCG Series

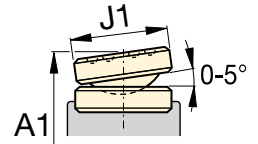

CATS-Series Tilt Saddle

Extended Height	Outside Diameter	Cylinder Bore Diameter	Plunger Diameter	Base to Advance Port	Standard Saddle Diameter	Saddle Protrusion from Plunger		Model Number
B (mm)	D (mm)	E (mm)	F (mm)	H (mm)	J (mm)	K (mm)	(kg)	
233	130	100	70	38	50	3	17	HCG502
333							20	HCG504
433							24	HCG506 ¹⁾
546							29	HCG508
646							32	HCG5010
746							36	HCG5012 ¹⁾
252	175	135	95	38	75	3	33	HCG1002
352							40	HCG1004
452							46	HCG1006
579							58	HCG1008
679							65	HCG10010
779							71	HCG10012
270	215	165	120	41	94	3	56	HCG1502
370							66	HCG1504
470							76	HCG1506
597							94	HCG1508
697							104	HCG15010
797							115	HCG15012
281	250	190	140	47	113	3	81	HCG2002
381							95	HCG2004
481							109	HCG2006
608							136	HCG2008
708							150	HCG20010
808							164	HCG20012
291	280	215	170	53	140	4	107	HCG2502
391							125	HCG2504
491							144	HCG2506
631							182	HCG2508
731							201	HCG25010
831							219	HCG25012
346	305	235	200	58	140	4	158	HCG3002
446							182	HCG3004
546							206	HCG3006
646							230	HCG3008
746							254	HCG30010
846							278	HCG30012

Optional Tilt Saddle		
Saddle Diameter J1 (mm)	Collapsed Height ²⁾ A1 (mm)	Saddle Model Number
71	197	CATS50
	247	
	297	
	360	
	410	
	460	
71	212	CATS101
	262	
	312	
	389	
	439	
	489	
97	239	CATS150
	289	
	339	
	416	
	466	
	516	
126	249	CATS200
	299	
	349	
	426	
	476	
	526	
175	280	CATS300
	330	
	380	
	470	
	520	
	570	
175	335	CATS300
	385	
	435	
	485	
	535	
	585	

²⁾ A1 = Collapsed height including CATS-Series tilt saddle.

HCG-Series, Single-Acting, Gravity Return Cylinders

- Hardened surface resists side-loading and cyclic wear
- Designed to withstand 10% side-load of maximum capacity
- Stop ring to prevent plunger blow-out
- Weather protected, inside and out
- Upper and lower replaceable bearings enclose the cylinder plunger for support throughout the stroke
- Certified lifting eyes, base mounting holes
- Optional collar threads on 300 ton models and higher capacities.

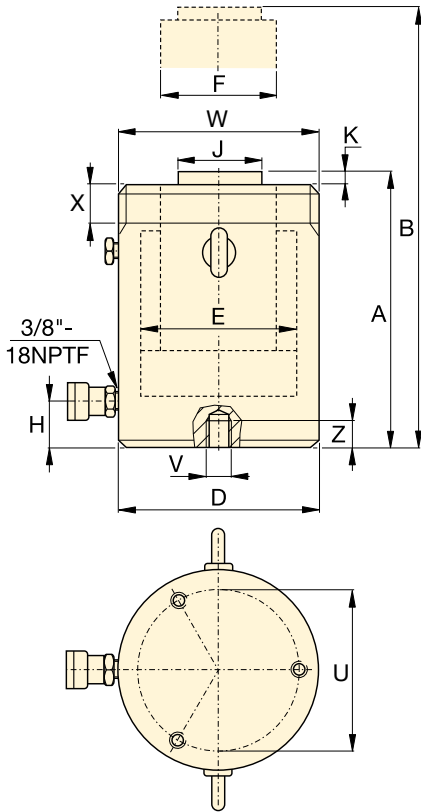

Optional Collar Thread (mm)		
Model / Capacity ton	Thread Size	Thread Length
	W	X
HCG400	M350 x 3	83
HCG500	M400 x 4	90
HCG600	M430 x 4	100
HCG800	M505 x 5	122
HCG1000	M570 x 5	137

Collar thread is optional on 300 ton models and higher. For collar thread on cylinder add suffix "E002" to model number. Example: **HCG400E002**

The collar thread length is designed for the full rated cylinder capacity.

Base Mounting Holes (mm)					
Model / Capacity ton	Bolt Circle	Thread Size	Minimum Thread Depth	Number of Holes	Angle from Coupler
	U	V	Z		
HCG400	300	M16 x 2	25	3	60°
HCG500	340	M24 x 3	36	3	60°
HCG600	370	M24 x 3	36	3	60°
HCG800	440	M24 x 3	36	3	60°
HCG1000	500	M24 x 3	36	3	60°

SELECTION CHART 400 - 1000 TON HCG-MODELS

For 50 - 300 ton models, see pages 48-49.

For full product features see pages 44-45.

Cylinder Capacity ton	Stroke (mm)	Model Number	Maximum Cylinder Capacity at 700 bar ton (kN)	Cylinder Effective Area (cm ²)	Oil Capacity (cm ³)	Collapsed Height A (mm)
400	50	HCG4002	409 (4008)	572,6	2863	321
	100	HCG4004			5726	371
	150	HCG4006			8588	421
	200	HCG4008			11.451	471
	250	HCG40010			14.314	521
	300	HCG40012			17.177	571
500	50	HCG5002	522 (5114)	730,6	3653	344
	100	HCG5004			7306	394
	150	HCG5006			10.959	444
	200	HCG5008			14.612	494
	250	HCG50010			18.265	544
	300	HCG50012			21.918	594
600	50	HCG6002	611 (5987)	855,3	4276	352
	100	HCG6004			8553	402
	150	HCG6006			12.829	452
	200	HCG6008			17.106	502
	250	HCG60010			21.382	552
	300	HCG60012			25.659	602
800	50	HCG8002	831 (8149)	1164,2	5821	404
	100	HCG8004			11.642	454
	150	HCG8006			17.462	504
	200	HCG8008			23.283	554
	250	HCG80010			29.104	604
	300	HCG80012			34.925	654
1000	50	HCG10002	1085 (10.644)	1520,5	7603	442
	100	HCG10004			15.205	492
	150	HCG10006			22.808	542
	200	HCG10008			30.411	592
	250	HCG100010			38.013	642
	300	HCG100012			45.616	692

Single-Acting, High Tonnage Cylinders



▲ Offshore wind turbines levelling: Enerpac's synchronous lifting system was the solution for levelling support cross pieces on 80 wind turbines.

HCG Series







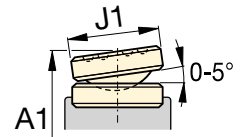

Capacity:
400 - 1000 ton

Stroke:
50 - 300 mm

Maximum Operating Pressure:
700 bar



CATS-Series Tilt Saddle

	Extended Height B (mm)	Outside Diameter D (mm)	Cylinder Bore Diameter E (mm)	Plunger Diameter F (mm)	Base to Advance Port H (mm)	Standard Saddle Diameter J (mm)	Saddle Protrusion from Plunger K (mm)		Model Number	Optional Tilt Saddle			
										Saddle Diameter J1 (mm)	Collapsed Height * A1 (mm)	Saddle Model Number	
	371	350	270	220	74	159	4		HCG4002	210	369	CATS400	
	471												419
	571												469
	671												519
	771												569
	871												619
	394	400	305	250	79	179	4		HCG5002	230	392	CATS500	
	494												442
	594												492
	694												542
	794												592
	894												642
	402	430	330	270	85	194	4		HCG6002	250	405	CATS600	
	502												455
	602												505
	702												555
	802												605
	902												655
	454	505	385	320	100	224	4		HCG8002	275	461	CATS800	
	554												511
	654												561
	754												611
	854												661
	954												711
	492	570	440	340	114	249	4		HCG10002	300	519	CATS1000	
	592												569
	692												619
	792												669
	892												719
	992												769

* A1 = Collapsed height including CATS-Series tilt saddle.

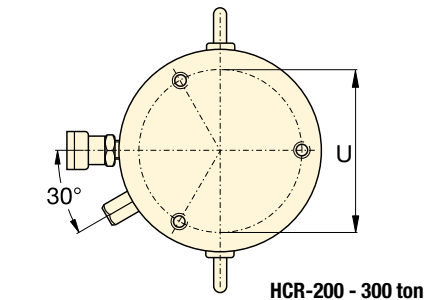
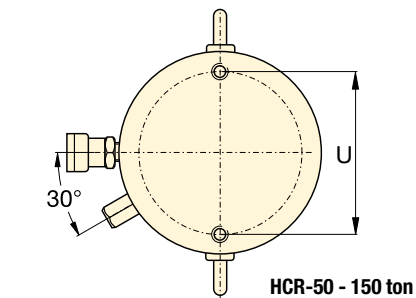
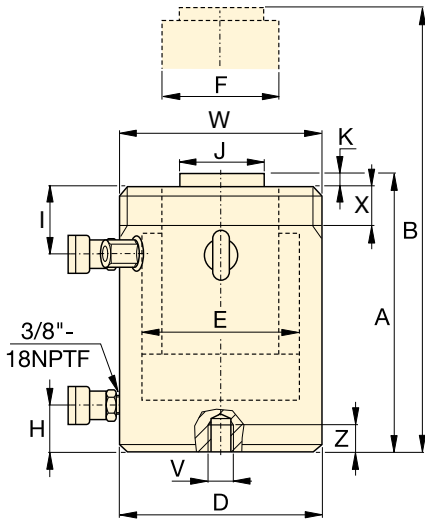

Collar Thread * (mm)		
Model / Capacity ton	Thread Size	Thread Length
	W	X
HCR50	M130 x 2	30
HCR100	M175 x 3	46
HCR150	M215 x 3	55
HCR200	M250 x 3	63
HCR250	M280 x 3	64
HCR300*	M305 x 3	73

* Standard collar thread up to 250 ton models. Collar thread is optional on 300 ton models and higher. For collar thread on cylinder add suffix "E002" to model number. **Example: HCR3006E002**
The collar thread length is designed for the full rated cylinder capacity.

Base Mounting Holes (mm)					
Model / Capacity ton	Bolt Circle	Thread Size	Minimum Thread Depth	Number of Holes	Angle from Coupler
	U	V	Z		
HCR50	105	M12 x 1,75	22	2	90°
HCR100	150	M12 x 1,75	22	2	90°
HCR150	185	M12 x 1,75	22	2	90°
HCR200	215	M12 x 1,75	22	3	60°
HCR250	245	M12 x 1,75	22	3	60°
HCR300	260	M16 x 2	25	3	60°

HCR-Series, Double-Acting Cylinders

- Fast advance and retract
- Designed to withstand 10% side-load of maximum capacity¹⁾
- Hardened surface resists side-loading and cyclic wear
- Weather protected, inside and out
- Upper and lower replaceable bearings enclose the cylinder plunger for support throughout the stroke
- Certified lifting eyes, base mounting holes and collar threads
- Standard collar thread up to 250 ton models. Collar thread is optional on 300 ton models and higher.

SELECTION CHART & DETAILS OF 50 - 300 TON HCR-MODELS

For 400 - 1000 ton models, see pages 54-55.

For full product features see pages 44-45.

Cylinder Capacity ton	Stroke (mm)	Model Number	Maximum Cylinder Capacity at 700 bar ton (kN)	Cylinder Effective Area (cm ²)	Oil Capacity (cm ³)		Collapsed Height A (mm)
					Advance	Retract	
50	50	HCR502	56 (550)	78,5	393	200	183
	100	HCR504			785	401	233
	150	HCR506 ¹⁾			1178	601	283
	200	HCR508			1571	801	346
	250	HCR5010			1963	1001	396
100	50	HCR1002	102 (1002)	143,1	716	361	202
	100	HCR1004			1431	723	252
	150	HCR1006			2147	1084	302
	200	HCR1008			2863	1445	379
	250	HCR10010			3578	1806	429
150	50	HCR1502	153 (1497)	213,8	1069	504	220
	100	HCR1504			2138	1007	270
	150	HCR1506			3207	1511	320
	200	HCR1508			4276	2015	397
	250	HCR15010			5346	2518	447
200	50	HCR2002	202 (1985)	283,5	1418	648	231
	100	HCR2004			2835	1296	281
	150	HCR2006			4253	1944	331
	200	HCR2008			5671	2592	408
	250	HCR20010			7088	3240	458
250	50	HCR2502	259 (2541)	363,1	1815	680	241
	100	HCR2504			3631	1361	291
	150	HCR2506			5446	2041	341
	200	HCR2508			7261	2721	431
	250	HCR25010			9076	3402	481
300	50	HCR3002	310 (3036)	433,7	2169	598	296
	100	HCR3004			4337	1196	346
	150	HCR3006			6506	1794	396
	200	HCR3008			8675	2392	446
	250	HCR30010			10.843	2989	496
	300	HCR30012			13.012	3587	546

¹⁾ HCR506 and HCR5012: 7% side-load of maximum capacity.

Double-Acting, High Tonnage Cylinders

Capacity:
50 - 300 ton

Stroke:
50 - 300 mm

Maximum Operating Pressure:
700 bar

HCR Series

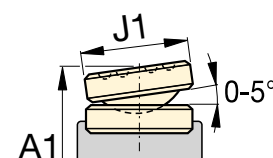

CATS-Series Tilt Saddle

	Extended Height B (mm)	Outside Diameter D (mm)	Cylinder Bore Diameter E (mm)	Plunger Diameter F (mm)	Base to Advance Port H (mm)	Top to Retract Port I (mm)	Standard Saddle Diameter J (mm)	Saddle Protrusion from Plunger K (mm)	 (kg)	Model Number	Optional Tilt Saddle					
											Saddle Diameter J1 (mm)	Collapsed Height ²⁾ A1 (mm)	Saddle Model Number			
	233	130	100	70	38	45	50	3	17	HCR502	71	197	CATS50			
	333								21	HCR504				247		
	433								25	HCR506 ¹⁾					297	
	546								31	HCR508						360
	646								34	HCR5010						
	746								38	HCR5012 ¹⁾					460	
	252	175	135	95	38	65	75	3	34	HCR1002	71	212	CATS101			
	352								41	HCR1004				262		
	452								48	HCR1006					312	
	579								59	HCR1008						389
	679								66	HCR10010						
	779								73	HCR10012					489	
	270	215	165	120	41	70	94	3	56	HCR1502	97	239	CATS150			
	370								67	HCR1504				289		
	470								78	HCR1506					339	
	597								95	HCR1508						416
	697								106	HCR15010						
	797								116	HCR15012					516	
	281	250	190	140	47	79	113	3	81	HCR2002	126	249	CATS200			
	381								96	HCR2004				299		
	481								111	HCR2006					349	
	608								139	HCR2008						426
	708								153	HCR20010						
	808								168	HCR20012					526	
	291	280	215	170	53	79	140	4	107	HCR2502	175	280	CATS300			
	391								127	HCR2504				330		
	491								146	HCR2506					380	
	631								184	HCR2508						470
	731								207	HCR25010						
	831								227	HCR25012					570	
	346	305	235	200	58	101	140	4	159	HCR3002	175	335	CATS300			
	446								183	HCR3004				385		
	546								208	HCR3006					435	
	646								232	HCR3008						485
	746								257	HCR30010						
	846								281	HCR30012					585	

²⁾ A1 = Collapsed height including CATS-Series tilt saddle.

HCR-Series, Double-Acting Cylinders

- Fast advance and retract
- Designed to withstand 10% side-load of maximum capacity
- Hardened surface resists side-loading and cyclic wear
- Weather protected, inside and out
- Upper and lower replaceable bearings enclose the cylinder plunger for support throughout the stroke
- Certified lifting eyes, base mounting holes and optional collar threads
- Optional collar threads on 300 ton models and higher capacities.

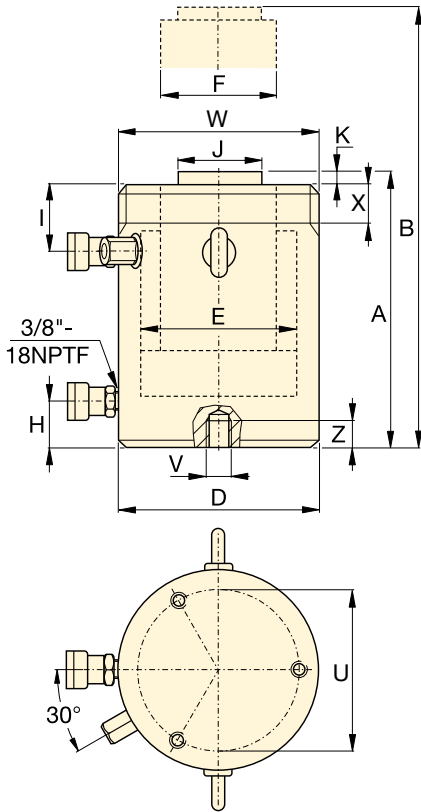

SELECTION CHART & DETAILS OF 400 - 1000 TON HCR-MODELS

For 50 - 300 ton models, see pages 52-53.

For full product features see pages 44-45.

Cylinder Capacity ton	Stroke (mm)	Model Number	Maximum Cylinder Capacity at 700 bar ton (kN)	Cylinder Effective Area (cm ²)	Oil Capacity (cm ³)		Collapsed Height A (mm)
					Advance	Retract	
400	50	HCR4002	409 (4008)	572,6	2863	962	321
	100	HCR4004			5726	1924	371
	150	HCR4006			8588	2886	421
	200	HCR4008			11.451	3848	471
	250	HCR40010			14.314	4811	521
	300	HCR40012			17.177	5773	571
500	50	HCR5002	522 (5114)	730,6	3653	1199	344
	100	HCR5004			7306	2397	394
	150	HCR5006			10.959	3596	444
	200	HCR5008			14.612	4795	494
	250	HCR50010			18.265	5994	544
	300	HCR50012			21.918	7192	594
600	50	HCR6002	611 (5987)	855,3	4276	1414	352
	100	HCR6004			8553	2827	402
	150	HCR6006			12.829	4241	452
	200	HCR6008			17.106	5655	502
	250	HCR60010			21.382	7069	552
	300	HCR60012			25.659	8482	602
800	50	HCR8002	831 (8149)	1164,2	5821	1800	404
	100	HCR8004			11.642	3599	454
	150	HCR8006			17.462	5399	504
	200	HCR8008			23.283	7198	554
	250	HCR80010			29.104	8998	604
	300	HCR80012			34.925	10.797	654
1000	50	HCR10002	1085 (10.644)	1520,5	7603	3063	442
	100	HCR10004			15.205	6126	492
	150	HCR10006			22.808	9189	542
	200	HCR10008			30.411	12.252	592
	250	HCR100010			38.013	15.315	642
	300	HCR100012			45.616	18.378	692

Optional Collar Thread (mm)

Model / Capacity ton	Thread Size	Thread Length
	W	X
HCR400	M350 x 3	83
HCR500	M400 x 4	90
HCR600	M430 x 4	100
HCR800	M505 x 5	122
HCR1000	M570 x 5	137

Collar thread is optional on 300 ton models and higher. For collar thread on cylinder add suffix "E002" to model number. Example: **HCR4006E002**

The collar thread length is designed for the full rated cylinder capacity.

Base Mounting Holes (mm)

Model / Capacity ton	Bolt Circle	Thread Size	Minimum Thread Depth	Number of Holes	Angle from Coupler
	U	V	Z		
HCR400	300	M16 x 2	25	3	60°
HCR500	340	M24 x 3	36	3	60°
HCR600	370	M24 x 3	36	3	60°
HCR800	440	M24 x 3	36	3	60°
HCR1000	500	M24 x 3	36	3	60°

Double-Acting, High Tonnage Cylinders



▲ The superlifting and launch of a 43,000-ton floating oil production system in Malaysia for the Gumusut-Kakap offshore field has set high benchmarks for safety through its use of sophisticated EVO-Series synchronous hydraulics to lift, balance, weigh and smoothly launch massive resource structures.

HCR Series



Capacity:
400 - 1000 ton

Stroke:
50 - 300 mm

Maximum Operating Pressure:
700 bar

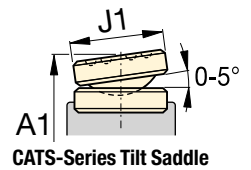

CATS-Series Tilt Saddle

Extended Height B (mm)	Outside Diameter D (mm)	Cylinder Bore Diameter E (mm)	Plunger Diameter F (mm)	Base to Advance Port H (mm)	Top to Retract Port I (mm)	Standard Saddle Diameter J (mm)	Saddle Protrusion from Plunger K (mm)	Model Number	Optional Tilt Saddle		
									Saddle Diameter J1 (mm)	Collapsed Height * A1 (mm)	Saddle Model Number
371	350	270	220	74	111	159	4	227	210	369	CATS400
471								258			
571								289			
671								321			
771								352			
871								383			
394	400	305	250	79	121	179	4	320	230	392	CATS500
494								361			
594								402			
694								443			
794								484			
894								525			
402	430	330	270	85	121	194	4	379	250	405	CATS600
502								427			
602								474			
702								521			
802								568			
902								615			
454	505	385	320	100	143	224	4	608	275	461	CATS800
554								674			
654								740			
754								806			
854								872			
954								938			
492	570	440	340	114	153	249	4	843	300	519	CATS1000
592								921			
692								1000			
792								1079			
892								1158			
992								1236			

* A1 = Collapsed height including CATS-Series tilt saddle.

HCL-Series, Single-Acting, Gravity Return Cylinders

- Lock nut provides positive and safe mechanical load holding
- Low-friction locking rings spin easy, save time and effort
- Designed to withstand 10% side-load up to 90% of maximum stroke
- Hardened surface resists side-loading and cyclic wear
- Overflow port as stroke limiter to prevent plunger blow-out
- Weather protected, inside and out
- Replaceable bearings enclose the plunger for support throughout the stroke
- Certified lifting eyes and base mounting holes.

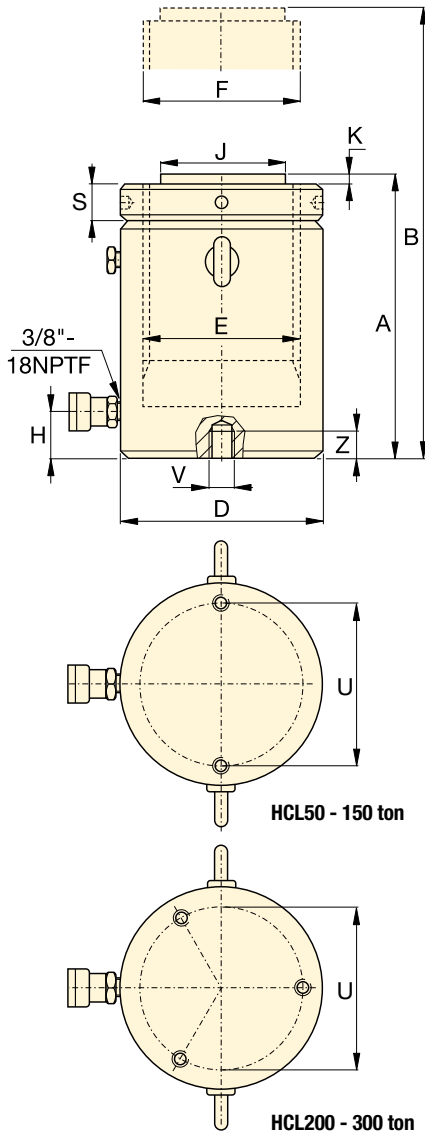

SELECTION CHART 50 - 300 TON HCL-MODELS

For 400 - 1000 ton models, see pages 58-59.

For full product features see pages 44-45.

Cylinder Capacity ton	Stroke (mm)	Model Number	Maximum Cylinder Capacity at 700 bar ton (kN)	Cylinder Effective Area (cm ²)	Oil Capacity (cm ³)	Collapsed Height A (mm)
50	50	HCL502	56 (550)	78,5	393	164
	100	HCL504			785	214
	150	HCL506			1178	264
	200	HCL508			1571	314
	250	HCL5010			1963	364
	300	HCL5012			2356	414
100	50	HCL1002	102 (1002)	143,1	716	187
	100	HCL1004			1431	237
	150	HCL1006			2147	287
	200	HCL1008			2863	337
	250	HCL10010			3578	387
	300	HCL10012			4294	437
150	50	HCL1502	153 (1497)	213,8	1069	209
	100	HCL1504			2138	259
	150	HCL1506			3207	309
	200	HCL1508			4276	359
	250	HCL15010			5346	409
	300	HCL15012			6415	459
200	50	HCL2002	202 (1985)	283,5	1418	238
	100	HCL2004			2835	288
	150	HCL2006			4253	338
	200	HCL2008			5671	388
	250	HCL20010			7088	438
	300	HCL20012			8506	488
250	50	HCL2502	259 (2541)	363,1	1815	249
	100	HCL2504			3631	299
	150	HCL2506			5446	349
	200	HCL2508			7261	399
	250	HCL25010			9076	449
	300	HCL25012			10.892	499
300	50	HCL3002	310 (3036)	433,7	2169	278
	100	HCL3004			4337	328
	150	HCL3006			6506	378
	200	HCL3008			8675	428
	250	HCL30010			10.843	478
	300	HCL30012			13.012	528

Base Mounting Holes (mm)					
Model / Capacity ton	Bolt Circle U	Thread Size V	Minimum Thread Depth Z	Number of Holes	Angle from Coupler
HCL50	105	M8 x 1,25	10	2	90°
HCL100	150	M12 x 1,75	17	2	90°
HCL150	185	M12 x 1,75	22	2	90°
HCL200	215	M12 x 1,75	22	3	60°
HCL250	245	M12 x 1,75	22	3	60°
HCL300	260	M16 x 2	25	3	60°

Single-Acting, Lock Nut Cylinders

Capacity:
50 - 300 ton

Stroke:
50 - 300 mm

Maximum Operating Pressure:
700 bar

HCL Series

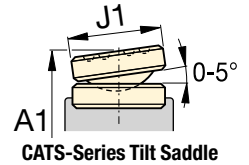

Extended Height	Outside Diameter	Cylinder Bore Diameter	Plunger Diameter (threaded)	Base to Advance Port	Standard Saddle Diameter	Saddle Protrusion from Plunger	Lock Nut Height	Model Number	Optional Tilt Saddle				
									Saddle Diameter J1 (mm)	Collapsed Height * A1 (mm)	Saddle Model Number		
214	130	100	Tr 100 x 4	24	71	2	25	17	HCL502	71	179	CATS100	
314								22					229
414								27					279
514								32					329
614								38					379
714								43					429
237	175	135	Tr 135 x 6	33	71	2	33	35	HCL1002	71	202	CATS100	
337								44					252
437								54					302
537								63					352
637								73					402
737								82					452
259	215	165	Tr 165 x 6	41	130	2	40	59	HCL1502	126	225	CATS201	
359								73					275
459								87					325
559								102					375
659								116					425
759								130					475
288	250	190	Tr 190 x 6	47	130	2	45	85	HCL2002	126	254	CATS201	
388								105					304
488								124					354
588								143					404
688								163					454
788								182					504
299	280	215	Tr 215 x 6	53	140	2	52	119	HCL2502	175	288	CATS300	
399								143					338
499								167					388
599								192					438
699								216					488
799								240					538
328	305	235	Tr 235 x 6	58	140	2	56	158	HCL3002	175	317	CATS300	
428								186					367
528								215					417
628								244					467
728								272					517
828								301					567

* A1 = Collapsed height including CATS-Series tilt saddle.

HCL-Series, Single-Acting, Gravity Return Cylinders

- Lock nut provides positive and safe mechanical load holding
- Low-friction locking rings spin easy, save time and effort
- Designed to withstand 10% side-load up to 90% of maximum stroke
- Hardened surface resists side-loading and cyclic wear
- Overflow port as stroke limiter to prevent plunger blow-out
- Weather protected, inside and out
- Replaceable bearings enclose the plunger for support throughout the stroke
- Certified lifting eyes and base mounting holes.

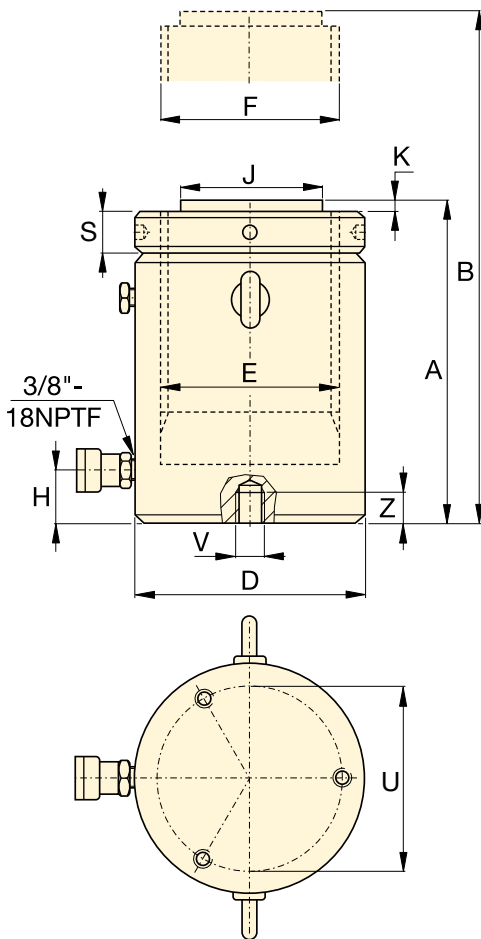

SELECTION CHART 400 - 1000 TON HCL-MODELS

For 50 - 300 ton models, see pages 56-57.

For full product features see pages 44-45.

Cylinder Capacity	Stroke	Model Number	Maximum Cylinder Capacity at 700 bar	Cylinder Effective Area	Oil Capacity	Collapsed Height
ton	(mm)		ton (kN)	(cm ²)	(cm ³)	A (mm)
400	50	HCL4002	409 (4008)	572,6	2863	317
	100	HCL4004			5726	367
	150	HCL4006			8588	417
	200	HCL4008			11.451	467
	250	HCL40010			14.314	517
	300	HCL40012			17.177	567
500	50	HCL5002	522 (5114)	730,6	3653	357
	100	HCL5004			7306	407
	150	HCL5006			10.959	457
	200	HCL5008			14.612	507
	250	HCL50010			18.265	557
	300	HCL50012			21.918	607
600	50	HCL6002	611 (5987)	855,3	4276	380
	100	HCL6004			8553	430
	150	HCL6006			12.829	480
	200	HCL6008			17.106	530
	250	HCL60010			21.382	580
	300	HCL60012			25.659	630
800	50	HCL8002	831 (8149)	1164,2	5821	430
	100	HCL8004			11.642	480
	150	HCL8006			17.462	530
	200	HCL8008			23.283	580
	250	HCL80010			29.104	630
	300	HCL80012			34.925	680
1000	50	HCL10002	1085 (10.644)	1520,5	7603	484
	100	HCL10004			15.205	534
	150	HCL10006			22.808	584
	200	HCL10008			30.411	634
	250	HCL100010			38.013	684
	300	HCL100012			45.616	734

Base Mounting Holes (mm)					
Model / Capacity ton	Bolt Circle U	Thread Size V	Minimum Thread Depth Z	Number of Holes	Angle from Coupler
HCL400	300	M16 x 2	25	3	60°
HCL500	340	M24 x 3	36	3	60°
HCL600	370	M24 x 3	36	3	60°
HCL800	440	M24 x 3	36	3	60°
HCL1000	500	M24 x 3	36	3	60°

Single-Acting, Lock Nut Cylinders



▲ Heavy lifting and foundation levelling. The lock nut provides mechanical load holding over a long period of time.

HCL Series



Capacity:
400 - 1000 ton

Stroke:
50 - 300 mm

Maximum Operating Pressure:
700 bar

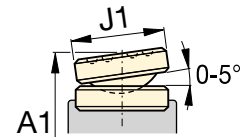

CATS-Series Tilt Saddle

Extended Height B (mm)	Outside Diameter D (mm)	Cylinder Bore Diameter E (mm)	Plunger Diameter (threaded) F (mm)	Base to Advance Port H (mm)	Standard Saddle Diameter J (mm)	Saddle Protrusion from Plunger K (mm)	Lock Nut Height S (mm)	 (kg)	Model Number	Optional Tilt Saddle			
										Saddle Diameter J1 (mm)	Collapsed Height * A1 (mm)	Model Number	
367	350	270	Tr 270 x 6	67	159	5	65	236	HCL4002	210	365	CATS400	
467								274	HCL4004				415
567								311	HCL4006				465
667								349	HCL4008				515
767								387	HCL40010				565
867								425	HCL40012				615
407	400	305	Tr 305 x 6	75	179	5	72	341	HCL5002	230	405	CATS500	
507								390	HCL5004				455
607								439	HCL5006				505
707								489	HCL5008				555
807								538	HCL50010				605
907								587	HCL50012				655
430	430	330	Tr 330 x 6	81	194	5	80	427	HCL6002	250	433	CATS600	
530								484	HCL6004				483
630								541	HCL6006				533
730								598	HCL6008				583
830								655	HCL60010				633
930								712	HCL60012				683
480	505	385	Tr 385 x 6	95	224	5	90	668	HCL8002	275	487	CATS800	
580								746	HCL8004				537
680								825	HCL8006				587
780								904	HCL8008				637
880								982	HCL80010				687
980								1061	HCL80012				737
534	570	440	Tr 440 x 6	110	249	5	105	959	HCL10002	300	561	CATS1000	
634								1059	HCL10004				611
734								1160	HCL10006				661
834								1260	HCL10008				711
934								1360	HCL100010				761
1034								1460	HCL100012				811

* A1 = Collapsed height including CATS-Series tilt saddle.

HCRL-Series, Double-Acting Lock Nut Cylinders



▼ HCRL-2006, HCRL-506



- Hydraulically controlled fast retraction
- Lock nut provides mechanical load holding for a safe work environment
- Designed to withstand up to 10% side-load of maximum capacity
- Integrated tilt saddle allows up to 5 degrees of misalignment
- Hardened surface resists side-loading and cyclic wear
- Weather protected, inside and out
- Replaceable bearings enclose the plunger external and internally for support
- Certified lifting eyes, base mounting holes and collar thread as standard
- Stop-ring to prevent plunger blow-out
- Low friction lock nut, to spin easily, save time and effort.

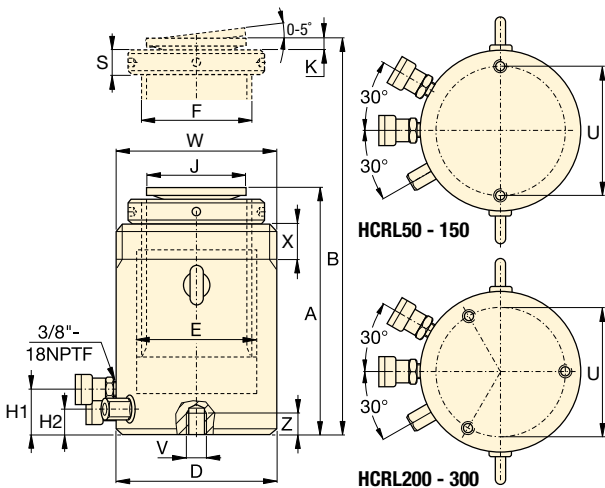

SELECTION CHART 50 - 300 TON HCRL-MODELS

For full product features see pages 44-45.

Cylinder Capacity * ton	Stroke * (mm)	Model Number	Maximum Cylinder Capacity at 700 bar ton (kN)	Cylinder Effective Area (cm ²)	Oil Capacity (cm ³)	
					Advance	Retract
50	150	HCRL506	49 (479)	68,4	1025	86
	200	HCRL508			1367	115
	250	HCRL5010			1709	143
	300	HCRL5012			2051	172
100	150	HCRL1006	101 (990)	141,4	2121	236
	200	HCRL1008			2827	314
	250	HCRL10010			3534	393
	300	HCRL10012			4241	471
150	150	HCRL1506	153 (1501)	214,4	3216	236
	200	HCRL1508			4288	314
	250	HCRL15010			5360	393
	300	HCRL15012			6432	471
200	150	HCRL2006	204 (2001)	285,9	4288	530
	200	HCRL2008			5718	707
	250	HCRL20010			7147	884
	300	HCRL20012			8577	1060
250	150	HCRL2506	251 (2463)	351,9	5278	530
	200	HCRL2508			7037	707
	250	HCRL25010			8796	884
	300	HCRL25012			10.556	1060
300	150	HCRL3006	303 (2969)	424,1	6362	530
	200	HCRL3008			8482	707
	250	HCRL30010			10.603	884
	300	HCRL30012			12.723	1060

* Up to 2000 ton and additional stroke lengths available on request.

Collar Thread (mm)		
Model / Capacity ton	Thread Size W	Thread Length X
HCRL50	M130 x 2	42
HCRL100	M185 x 2	57
HCRL150	M222 x 3	70
HCRL200	M260 x 3	79
HCRL250	M290 x 3	85
HCRL300	M315 x 3	94

The collar thread length is designed for the full rated cylinder capacity.

Base Mounting Holes (mm)			
Model / Capacity ton	Bolt Circle U	Thread Size V	Minimum Thread Depth Z
HCRL50	105	M12 x 1,75	22
HCRL100	150	M12 x 1,75	22
HCRL150	185	M12 x 1,75	22
HCRL200	215	M12 x 1,75	22
HCRL250	245	M12 x 1,75	22
HCRL300	260	M16 x 2	25

Double-Acting Lock Nut Cylinders



Higher Capacities, Larger Strokes

The HCRL-Series Cylinders are available up to 2000 ton capacity and additional stroke lengths available on request.

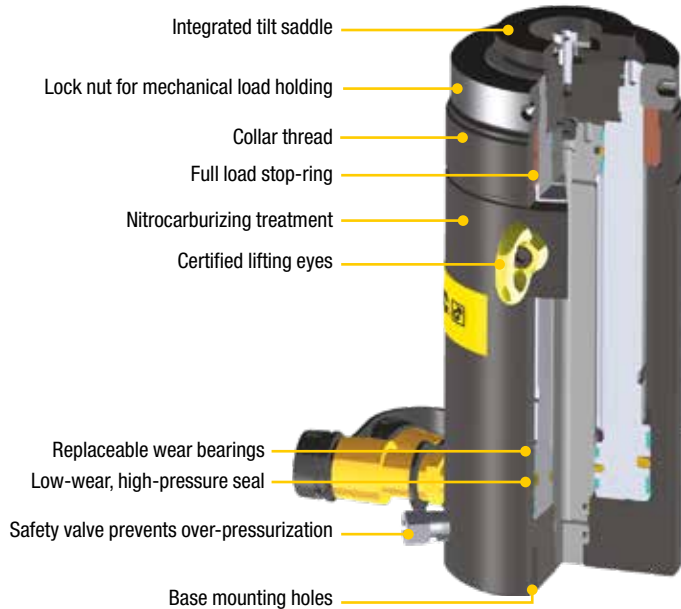

HCRL Series

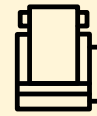

Capacity:

50 - 300 ton

Stroke:

150 - 300 mm

Maximum Operating Pressure:

700 bar



Synchronous Lifting Systems

EVO-Series pumps the multi-functional lifting system and multiple lift point capabilities.

Page: **350**

Collapsed Height	Extended Height	Outside Diameter	Cylinder Bore Diameter	Plunger Diameter (threaded)	Base to Advance Port H1	Base to Retract Port H2	Saddle Diameter	Saddle Protrusion	Lock Nut Height		Model Number
A (mm)	B (mm)	D (mm)	E (mm)	F (mm)	H1 (mm)	H2 (mm)	J (mm)	K (mm)	S (mm)	(kg)	
310	460	130	100	Tr 90 x 4	41	27	77	15	26	30	HCRL506
377	577									36	HCRL508
427	677									40	HCRL5010
477	777									45	HCRL5012
346	496	185	140	Tr 120 x 6	50	36	77	15	36	64	HCRL1006
421	621									77	HCRL1008
471	721									85	HCRL10010
521	821									94	HCRL10012
359	509	222	170	Tr 150 x 6	46	32	126	13	45	97	HCRL1506
434	634									116	HCRL1508
484	734									129	HCRL15010
534	834									142	HCRL15012
399	549	260	200	Tr 170 x 6	71	49	126	13	50	145	HCRL2006
469	669									168	HCRL2008
519	769									184	HCRL20010
569	869									200	HCRL20012
416	566	290	220	Tr 190 x 6	71	49	160	15	55	190	HCRL2506
491	691									224	HCRL2508
541	791									244	HCRL25010
591	891									265	HCRL25012
421	571	315	240	Tr 210 x 6	71	49	160	15	55	230	HCRL3006
496	696									269	HCRL3008
546	796									294	HCRL30010
596	896									319	HCRL30012

▼ SCR1010H cylinder-pump set



The Quickest and Easiest Way to Start Working Right Away



Speed Chart

See the Enerpac Cylinder Speed Chart in our 'Yellow Pages' section.

Page: 415

- Optimum match of individual components
- All sets are ready-for-use
- Sets include 1,8 m safety hose and gauge with gauge adaptor
- All pumps are two-speed.

1 Cylinder Selection (See Cylinder Section of this catalog for full product descriptions)		Set Capacity ton (kN)	Cylinder Model Number	Stroke (mm)	Collapsed Height (mm)
<p>RC-Series, Single-Acting, General Purpose Cylinders For maximum versatility.</p>	<p>Page: 6</p>	5 (45)	RC55	127	216
		10 (101)	RC102	54	121
			RC106	156	248
			RC1010	257	349
		15 (142)	RC154	101	200
			RC156	152	271
		25 (232)	RC252	50	165
			RC254	102	216
			RC256	158	273
			RC2514	362	476
50 (498)	RC506	159	282		
<p>RCS-Series, Single-Acting, Low-Height Cylinders Ideal where space is restricted.</p>	<p>Page: 26</p>	10 (101)	RCS101	38	88
		20 (201)	RCS201	45	98
		30 (295)	RCS302	62	117
		45 (435)	RCS502	60	122
		90 (887)	RCS1002	57	141
<p>RCH-Series, Single-Acting, Hollow Cylinders For pushing and pulling applications.</p>	<p>Page: 34</p>	13 (125)	RCH121	42	120
		20 (215)	RCH202	49	162
		30 (326)	RCH302	64	178
		60 (576)	RCH603	76	247
		95 (933)	RCH1003	76	254

Single-Acting Cylinder-Pump Sets

SET SELECTION:

- 1 Select the cylinder
- 2 Select the pump
- 3 Find the set model number in the gray matrix

SELECTION EXAMPLE

Selected cylinder:

- RC106, Single-Acting cylinder with 156 mm stroke

Selected pump:

- P392, Lightweight hand pump

Set model number:

- SCR106H

Included:

- HC7206 hose
- GF10B gauge
- GA2 adaptor



GA45GC Gauge Adaptor Assembly

Protect yourself from system overloading by simply ordering one partnumber for a pre-assembled gauge, gauge adaptor and coupler.

Page: 142

SC Series



Capacity:

5 - 95 ton

Stroke:

38 - 362 mm

Maximum Operating Pressure:

700 bar



Power Box

Tool box with hand pump, gauge adaptor assembly, hose and LW-, RC-, RCS, RSM- or WR-Series cylinder.

Page: 65

2

Pump selection (See the Pump Section in this catalog for full product descriptions.)

Accessories included

3

Hand Pump P142	Hand Pump P392	Hand Pump P80	Foot Pump P392FP	XA-Series Air Pump XA11	XC-Series Cordless Pump XC1201ME ²⁾	Hose Model Number	Gauge Model Number	Gauge Adaptor Model Nr.
SCR55H	-	-	-	-	-	HC7206	GP10S	GA4
-	SCR102H	-	SCR102FP	SCR102XA	SCR102XCE	HC7206	GF10B	GA2
-	SCR106H	-	SCR106FP	SCR106XA	SCR106XCE	HC7206	GF10B	GA2
-	SCR1010H	-	SCR1010FP	SCR1010XA	SCR1010XCE	HC7206	GF10B	GA2
-	SCR154H	-	SCR154FP	SCR154XA	SCR154XCE	HC7206	GP10S	GA2
-	SCR156H	-	SCR156FP	SCR156XA	SCR156XCE	HC7206	GP10S	GA2
-	SCR252H	-	SCR252FP	SCR252XA	SCR252XCE	HC7206	GF20B	GA2
-	SCR254H	-	SCR254FP	SCR254XA	SCR254XCE	HC7206	GF20B	GA2
-	SCR256H	-	-	SCR256XA	SCR256XCE	HC7206	GF20B	GA2
-	-	SCR2514H	-	SCR2514XA ¹⁾	-	HC7206	GF20B	GA2
-	-	SCR506H	-	SCR506XA ¹⁾	-	HC7206	GF50B	GA2
-	SCL101H	-	SCL101FP	SCL101XA	-	HC7206	GF10B	GA2
-	SCL201H	-	SCL201FP	SCL201XA	-	HC7206	GF230B	GA2
-	SCL302H	-	SCL302FP	SCL302XA	SCL302XCE	HC7206	GF230B	GA2
-	SCL502H	-	SCL502FP	SCL502XA	SCL502XCE	HC7206	GF510B	GA2
-	-	SCL1002H	-	-	SCL1002XCE	HC7206	GF510B	GA2
SCH121H	-	-	-	-	-	HB7206	GF120B	GA4
-	SCH202H	-	SCH202FP	SCH202XA	SCH202XCE	HC7206	GF813B	GA3
-	SCH302H	-	SCH302FP	SCH302XA	SCH302XCE	HC7206	GF813B	GA3
-	-	SCH603H	-	SCH603XA ¹⁾	SCH603XCE	HC7206	GF813B	GA3
-	-	SCH1003H	-	-	-	HC7206	GP10S	GA2

¹⁾ With XA12 air pump.

²⁾ Cordless Pump includes 230V Charger. For 115V charger replace the "E" by the "B" in the model number.

▼ From left to right: P142ALSS, P392ALSS, V152NV, V66NV, RC256NV, RC106NV, RC53NV



- Corrosion resistant, nickel-plated valves and cylinders
- Stainless steel pump inserts will not corrode
- Viton® Seals provide heat and chemical resistance
- Anodized aluminum pump reservoirs and plastic encapsulated pump bodies resist wet environments
- Two-speed operation reduces pump handle strokes 78% compared to single-speed pumps
- Pump handles lock for easy carrying.

RC, P, V Series

Cylinder Capacity:
5 - 25 ton

Stroke:
51 - 156 mm

Maximum Operating Pressure:
700 bar



Applications







For use in wet environments such as food processing, pulp and paper, mining, construction and applications in high temperature or in welding areas.



Multifluid Hand Pumps

MP-Series corrosion resistant hand pumps for low pressure filling and high pressure testing applications, suitable for a wide range of fluids.

Page: **82**

	Cylinder Capacity	Stroke	Model Number *	Oil Capacity	Pressure Rating	Collapsed Height	Extended Height	Outside Diameter	
	ton (kN)	(mm)		(cm ³)	(bar)	(mm)	(mm)	(mm)	(kg)
	5 (45)	76	RC53NV	50	700	165	241	38	1,5
	10 (101)	51	RC102NV	78	700	121	175	57	2,3
	10 (101)	156	RC106NV	225	700	247	403	57	4,4
25 (232)	156	RC256NV	528	700	273	431	85	10,0	
	Pump Type	Oil Capacity	Model Number *	Pressure Rating	Oil Displacement per Stroke	Port Dimension	Piston Stroke		
		(cm ³)		(bar)	(cm ³)	(NPTF)	(mm)	(kg)	
	Two Speed	327	P142ALSS	14 / 700	3,62 / 0,90	1/4"-18	12,7	2,0	
	901	P392ALSS	14 / 700	11,26 / 2,47	3/8"-18	25,4	4,1		
	Valve Type		Model Number *	Function			Pressure Rating		
							(bar)	(kg)	
	Manual Check Valve		V66NV *	Load holding with cylinders			700	1,8	
Pressure Relief Valve		V152NV *	Limits system pressure, ± 3% repeatability			55-700	1,6		

* For cylinder details see pages 7-9; for pump details see pages 76-77; for valve details see pages 144-145.

Power Box – Portable Tool Sets

▼ SCR154PGH



- Easy to carry sturdy tool box
- Complete and ready-to-use hydraulic sets
- Includes a single-acting cylinder, P392 two-speed lightweight hand pump, gauge adaptor assembly, 1,8 metres hose and couplers
- All components ship inside tool box as one package.

**SC,
SL,
SR,
SW
Series**



Capacity:

1 - 45 ton

Stroke:

11 - 156 mm

Maximum Operating Pressure:





700 bar



Gauge Adaptor Assembly

Power Box Sets include 45 degree angled gauge adaptor assembly for improved safe working conditions.

Page: 127

	Cylinder Model	Cylinder Stroke (mm)	Cylinder Capacity ton (kN)	Weight (kg)	Power Box Model Number
	Lifting Wedge				
	LW16	21	16 (157)	9,0	SLW16PGH ²⁾
	Wedge Spread Cylinder				
	WR5	94 ¹⁾	1,0 (8,9)	12,0	SWR5PGH
	General Purpose Cylinders				
	RC102	54	10 (101)	12,3	SCR102PGH
	RC106	156	10 (101)	14,4	SCR106PGH
	RC154	101	15 (142)	15,0	SCR154PGH
	RC156	152	15 (142)	16,8	SCR156PGH
	Low-Height Cylinders				
	RCS101	38	10 (101)	14,1	SCL101PGH
	RCS201	45	20 (201)	15,0	SCL201PGH
	Low-Height Cylinders				
	RSM100	11	10 (101)	11,4	SRS100PGH
	RSM200	11	20 (201)	13,1	SRS200PGH
	RSM300	13	30 (295)	14,5	SRS300PGH
	RSM500	16	45 (435)	16,8	SRS500PGH

¹⁾ Maximum spread of WR5.

²⁾ With P142 two-speed lightweight hand pump.

▼ The Power Box – the portable tool set – applicable everywhere.



▼ Shown from left to right: JHA356, JHA156



JH, JHA Series

Capacity:
7 - 100 ton

Stroke:
76 - 155 mm

Maximum Operating Pressure:
700 bar

- All-directional operation on 7, 15 and 35 ton JHA-series
- Internal relief valve to prevent overloading
- Machined flat front and bottom surfaces permit flush alignment in tight corners
- Chrome plated plungers
- Pumping handle included
- Automatic by-pass port to prevent over-extension (JH-series).



Lifting Wedge and Machine Lifts

Ideal to lift the load the first few centimeters. The LW16 Lifting Wedge requires a very small access gap of only 10 mm.

Page: **188**



Load Skates

For moving heavy loads easily and safely.

Page: **192**

Style	Jack Capacity ton (kN)	Stroke (mm)	Model Number	Jack Effective Area (cm ²)	Collapsed Height (mm)	Extended Height (mm)	Bottom Plate Dimensions W x L (mm)	Plunger Diameter (mm)	Pump Speed	 (kg)
Aluminium Jacks	7 (62)	76	JHA73	9,6	133	209	73 x 158	30,2	Single	5,0
	15 (133)	153	JHA156	20,3	247	401	92 x 238	41,4	Single	13,2
	35 (311)	155	JHA356	45,6	257	412	117 x 254	54,1	Single	18,1
Steel Jacks	30 (267)	155	JH306	38,3	254	409	95 x 242	69,9	Single	26,8
	50 (445)	154	JH506	62,1	260	414	127 x 258	88,9	2-Speed	40,8
	100 (890)	153	JH1006	133,1	287	440	181 x 328	130,1	2-Speed	74,4

Industrial Steel Bottle Jacks

▼ Shown: GBJ010A, GBJ030A, GBJ003A



- Lower handle effort reduces operator fatigue
- Fully serviceable
- High-strength beam and pump linkage for long life
- Pumping handle included on all models
- Safety relief valve to prevent overload
- Automatic by-pass port to prevent over-extension
- Wiper seal for extended life
- Thick base material with large area for increased strength and stability during lifting
- Positioning handle on 20 ton through 50 ton models.

GBJ Series



Capacity:

2 - 100 ton

Stroke:

62 - 460 mm



Screw Extension Feature

Heat treated, adjustable extension screw with cleated saddle on selected GBJ models helps adjusting and prevents slipping.

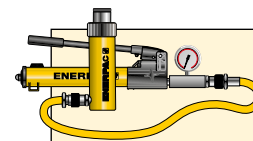

Cylinder-Pump Sets

As an alternative to bottle jacks where the operator is required to stand remote from the jacking point, see our range of cylinder-pump sets.

Page: **62**

Capacity ton (kN)	Stroke (mm)	Model Number	Screw Extension (mm)	Min. Height (mm)	Max. Height (mm)	Plunger diameter (mm)	Saddle Diameter (mm)	Bottom Dimensions W x L (mm)	 (kg)
2 (19,6)	460	GBJ002LA	-	570	1030	29	-	127 x 127	10,0
3 (29,4)	105	GBJ003A	65	168	338	24	23,5	75 x 116	3,7
5 (49,0)	150	GBJ005A	75	212	437	29	28,5	75 x 125	4,5
8 (78,4)	150	GBJ008A	75	219	444	37	38,0	90 x 144	6,2
10 (98,0)	150	GBJ010A	75	219	444	37	38,0	90 x 144	6,4
10 (98,0)	62	GBJ010SA	30	131	223	37	38,0	90 x 144	5,0
15 (147,0)	150	GBJ015A	75	228	453	45	45,0	112 x 163	8,8
20 (196,0)	150	GBJ020A	75	234	459	51	61,0	120 x 172	10,6
20 (196,0)	105	GBJ020SA	55	190	350	51	61,0	120 x 172	9,5
30 (294,0)	150	GBJ030A	75	242	467	58	69,0	144 x 196	15,5
50 (490,0)	140	GBJ050A	-	260	400	80	80,0	165 x 214	27,0
100 (980,0)	150	GBJ100	-	300	450	110	94,0	296 x 333	87,0

All GBJ Jacks meet or exceed: ANSI, PALD, CE.

▼ Enerpac heavy-duty bottle jacks make lifting loads easier.



▼ Shown: PRASA10027L and accessory Locking U-Rings



Safe, Efficient, Mobile Load Lifting



Pendant cord

Supplied with 3,5 m pendant cord for air driven units with pneumatic valves and 6 m pendant cord for electric driven units keeps operator away from the load.

- 54, 90, 136 and 181 ton capacities with pneumatic or electric pumps for the toughest jobs
- 102 mm ground clearance for transport over rail and rough terrain
- Double-acting cylinder
- Three position handle provides easy tilt back and transport
- Complies with ASME/ANSI B30:1 2015 and CE specifications
- Easy to change external filter minimizes down time
- Rugged, fully enclosed 610 mm wide frame with no exposed fittings or hoses
- SUP-R-STACK™ Extension System allows lifting at all heights without blocking.



POW'R-LOCK™ – Self-Locking Mobile Lift System

A self-locking jack that performs automatic locking during lifting, lowering and holding.

See the Enerpac PL-Series

Page: 70



◀ Enerpac POW'R-RISER® used in mining operations to lift heavy equipment.

Capacity ton (kN)	Stroke (mm)	Model Number with Electric Pump (230V - 1 ph - 50Hz)	 (kg)
54 (533)	356	PREME06014L	177
	686	PREME06027L	272
90 (889)	406	PREME10016L	231
	686	PREME10027L	272
	406	-	-
	686	-	-
136 (1333)	394	-	-
	673	-	-
	394	PREME15016L	258
	673	PREME15027L	321
181 (1778)	388	-	-
	617	-	-

POW'R-RISER® Lifting Jack



SUP-R-STACK Extensions

Increase useful height from 127 to 457 mm.

Model No.	Size (mm)	Model No.	Size (mm)
PRE5	127	PRE11	279
PRE7	178	PRE14	356
PRE9	229	PRE18	457
PRES6024	Extension set includes PRE5, PRE7, PRE11 and PRE18.		



Spacers

Fine tune your extension stack height.

Model No.	Size (mm)	Model No.	Size (mm)
PRS1	25	PRS3	76
PRS2	51	-	-
PRS4	Set includes (2x) PRS1, (1x) PRS2 and (1x) PRS3.		

PR Series



Rated Lifting Capacity:

54 - 181 ton

Stroke:

356 - 686 mm

Maximum Operating Pressure:

700 bar

Cap. (kN)	Swivel Load Saddle	Locking U-Rings					Set Model Number	Locking U-Ring Sets Include:								
		25 mm	76 mm	114 mm	140 mm	254 mm		Quantity & model numbers								
533	PRTS60	PRU11	PRU13	PRU14	-	PRU110	¹⁾ PRUS126	PRU11	PRU13	PRU14	-	²⁾ PRUS137	PRU11	PRU13	PRU14	PRU110
889	PRTS60	PRU11	PRU13	PRU14	-	PRU110	¹⁾ PRUS126	PRU11	PRU13	PRU14	-	²⁾ PRUS137	PRU11	PRU13	PRU14	PRU110
1333	PRTS150	PRU151	PRU153	-	PRU155	PRU1510	³⁾ PRUS1526	PRU151	PRU153	PRU155	-	²⁾ PRUS1537	PRU151	PRU1510	PRU155	-
1778	PRTS200	PRU201	PRU203	-	PRU205	PRU2010	³⁾ PRUS2026	PRU201	PRU203	PRU205	-	²⁾ PRUS2037	PRU201	PRU2010	PRU205	-

¹⁾ For 356 mm and 406 mm stroke models

²⁾ For 686 mm stroke models

³⁾ For 394 mm stroke models.

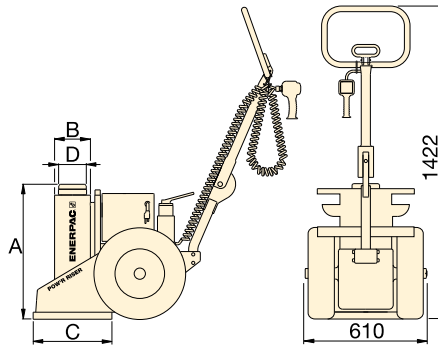

WARNING!

Extensions: Any two extensions may be stacked for loads up to 54 ton. For loads over 54 ton or strokes over 356 mm only one extension and one spacer can be used.

Spacers: Never exceed 76 mm in total spacer height.

Model Number with Air Pump	(kg)	A (mm)	B (mm)	C (mm)	D (mm)	Max. Additional Stack Height Using Optional Extension (mm)	Valve Type
PRAMA06014L	177	610	162	356	102	813*	Manual
PRAMA06027L	272	940	162	356	102	279	
PRAMA10016L	231	660	178	457	102	533**	
PRAMA10027L	272	940	178	457	102	279	
PRASA10016L	231	660	178	457	102	533**	Pneumatic
PRASA10027L	272	940	178	457	102	279	
PRASA15016L	258	660	203	457	127	533**	
PRASA15027L	321	940	203	457	127	279	Manual
-	-	660	203	457	127	533**	
-	-	940	203	457	127	279	Pneumatic
PRASA20016L	290	660	241	508	165	533**	
PRASA20027L	374	940	241	508	165	279	

* Based on one 457 mm and one 279 mm extension and one 76 mm spacer.

** Based on one 457 mm extension and one 76 mm spacer.

For power source, the following characters should be inserted in the 5th space of the model number.

Ordering Example:

Model No. PREME06014L is a 356 mm stroke, 54 ton model, with a manual valve and a 230 VAC, 1-ph, 50 Hz electric motor.

A Air Pump, 1416 l/min air consumption at 5,5 bar

B 115 VAC, 1-ph., 50-60 Hz, 20 A

E 208-240 VAC, 1-ph., 50-60 Hz, Euro Plug, 10 A

I 208-240 VAC, 1-ph., 50-60 Hz, USA Plug, 10 A

G ¹⁾ 208-240 VAC, 3-ph., 50-60 Hz

W ¹⁾ 380-415 VAC, 3-ph., 50-60 Hz

J ¹⁾ 440-480 VAC, 3-ph., 50-60 Hz

R ¹⁾ 575 VAC, 3-ph., 50-60 Hz.

¹⁾ Not available for 54 ton capacity.

▼ Shown: PL20025-ASA and PL20014-ASA



- Provides continuous locking protection during lift, lower and hold functions
- Patent-pending control technology synchronizes cylinder and lock nut for smooth and efficient lifting and lowering
- Unique double-acting cylinder offers a low collapsed height to accommodate more lifting applications
- Simple 2-button pendant allows operation of raise and lower functions from up to 6,1 metres away
- All load-bearing cylinder components have a nitrocarburized treatment to improve wear characteristics and resist corrosion
- Ergonomic handle has six positions for comfortable handling and folds when not in use
- Meets ANSI/ASME B30.1-2015, AS/NZS-2538, AS/NZS-2693 certification criteria.



Efficient Lifting with Continuous Automatic Load Locking



POW'R-LOCK™ Self-Locking Lift System

Only the POW'R-LOCK™ Lift System provides continuous positive locking of the load through all stages of lifting and lowering. No operator intervention is required to activate or de-activate the automatic locking system.

Two different stroke lengths are available. Both models are powered by an external compressed air system (user-supplied).

A convenient two-button pendant controls operation of the Lift System's air motor and directional control valve.



Tilt Load Cap

All POW'R-LOCK™ Lift System models feature a Tilt Load Cap to reduce side-loading.



Safety First

When lifting large, heavy vehicles certain precautions must be followed. Follow your published safety directions for lifting and cribbing your loads. The Pow'R-LOCK™ Lift System provides load/lock protection, but you must follow the safety directions for load cribbing operations.

◀ The PL-Series POW'R-LOCK™ Portable Lift System.

POW'R-LOCK™ Mobile Lift System



Accessories

Flat Load Cap – Non-tilt load cap has lower profile for tight lifting spaces.

Spacers – Minimize gap between load cap and lifting point to maximize hydraulic stroke of the jack.

Extensions – Stackable, with large alloy steel locating studs to resist effects of side-loading.

Extension Base Adapter – Extension Base Adapter design eliminates risk of improper stacking when using more than one extension.

PL Series



Rated Lifting Capacity:

181 ton

Stroke:

356 - 622 mm

Maximum Operating Pressure:

700 bar

Model Number	Description	Height (mm)	PL20014-ASA	PL20025-ASA
PLC1	Flat Load Cap	34	x	x
PLS1	Spacer	26	x	x
PLS2	Spacer	51	x	x
PLE5	Extension	127	x	x
	PLE7	Extension	178	x
	PLE9	Extension	229	x
	PLE11	Extension	280	x
PLE14	Extension	356	x	-
PLB12	Extension base adapter	305	x	-



WARNING!

PLE11 and PLE14 Extensions and PLB12 Extension Base Adapter are to be used with the "short" model **PL20014-ASA** only. Use of these extensions on the "tall" model **PL20025-ASA** will result in an excessive maximum lifting height. Load could become unstable and drop, resulting in possible personal injury and/or property damage.

Model Number	Maximum Additional Stack Height *
PLS20014-ASA	712 mm
PLS20025-ASA	229 mm

* Using optional PLB and PLE-Series extensions and PLS-Series spacers. Load cap height is NOT included in the stack height.

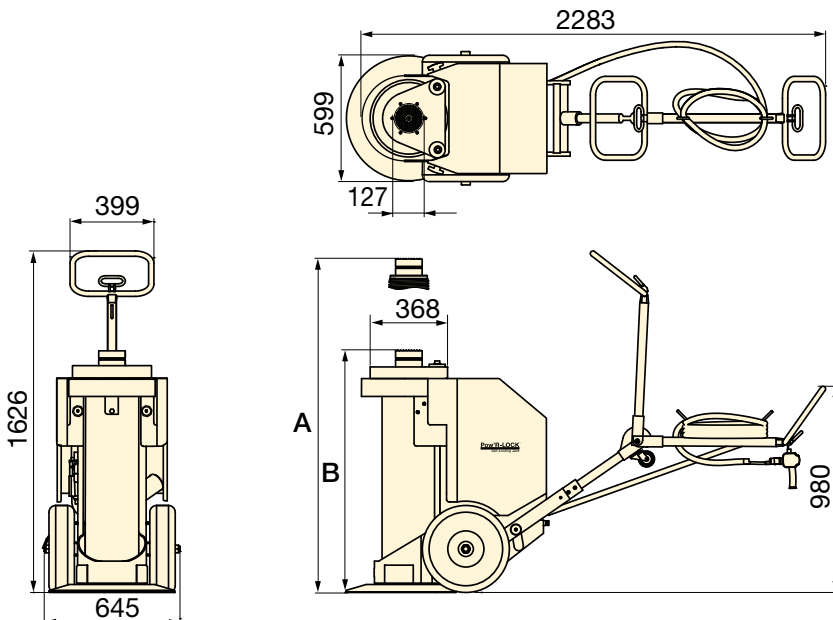

PR-Series, POW'R-RISER® Mobile Lifting Jack

When automatic load-locking is not required, the POW'R-RISER® jack provides a mobile lifting solution.

Page: 68

Capacity ton (kN)	Stroke (mm)	Model Nr. with Air Pump	Cylinder Lifting Speed ¹⁾ (mm/min)		Recommended Air Supply ²⁾		A ³⁾ (mm)	B ³⁾ (mm)	 (kg)
			Load	No Load	(l/min)	(bar)			
181 (1779)	356	PL20014-ASA	51	61	3681 - 4247	3,8 - 6,9	1219	864	501
	622	PL20025-ASA	51	61			1778	1156	599

¹⁾ Depending on available airflow, regulator setting, pump speed and load weight.

²⁾ Minimum dynamic air pressure of 3,8-4,1 bar. 6,2-6,9 bar required to achieve 1779 kN capacity.

³⁾ Height A and B are with Swivel Load Cap installed. Subtract 51 mm if flat load cap is used.

There's no substitute for experience in customizing hydraulic cylinders and Enerpac meets the needs of the most demanding applications.

Cylinders are the primary workhorse in hydraulic systems required to push or pull. Although Enerpac offers a wide variety of cylinders to fit many application requirements, there are many applications that require customization.

These may include special corrosion protection, ability to handle extreme side loads, or having special mounting needs.



◀ Large capacity, double-acting lock nut cylinders with an external lock ring used for bridge work.



◀ Double-acting cylinders with pilot-operated check valves and rod eyes on both ends for lifting and positioning applications.



◀ Custom private-label cylinders for OEM applications.

Overview Custom Cylinders



▲ Custom 500 ton double-acting cylinders with 1,83 m stroke for lifting electric rope shovels.

CUSTOMIZABLE FEATURES:

- Stroke
- Capacity
- Paint
- Pressure Rating
- Fitting
- Special Attachments
- Seals
- Imbedded Sensors
- Collapsed Height
- Rod Modifications
- Special Mounting
- Corrosion Resistance



Custom Hydraulic Pumps

Enerpac offers a wide variety of hydraulic pumps for all your custom needs. Still, many applications require a customized pump to operate the system.

Overview Enerpac Heavy Lifting Capabilities



344

SFP-SERIES, SPLIT-FLOW PUMPS

The split-flow pump is an economical solution for multi-point controlled lifting applications. Split-Flow pumps distribute an equal amount of hydraulic oil to a maximum of 8 outlets.



348

EVO-SERIES, SYNCHRONOUS LIFTING SYSTEMS

EVOP-Series: Each EVOP-pump (Pump-per-Point) controls only one lifting point, providing the best combination of high flow rate and exceptional accuracy.

EVO-Series: Modular and multi-functional pumps to control 4, 8 or 12 lifting points. Network capability to link up to 48 lifting points with 4 EVO-units.



352

SCJ-SERIES, SELF-LOCKING CUBE JACKS

Compact incremental lifting system with automated mechanical locking. Safe, more efficient alternative to the jack-and-pack method with wooden cribbing. Cube Jack utilizes base lifting frames and self-aligning, lightweight steel cribbing blocks.



356

BLS-SERIES, CLIMBING JACKS

Double-acting stage lift cylinders with solid plunger design allows for a load to be lifted many times the stroke of the cylinder. The solution for incremental lifting.



358

JS-SERIES, JACK-UP SYSTEMS

The jack up system is a custom developed multi-point incremental lifting system – synchronously lift and mechanically hold. A typical system setup includes four jack up units positioned under each corner of a load.



360

HSL-SERIES, HEAVY LIFTING STRAND JACKS

Compact high capacity system for controlled lifting and lowering. Strand jack systems that provide fully controlled precise lifting.



362

SHS, SHAS-SERIES, SYNCHOIST

High precision hoisting and load positioning systems to enhance a crane's capability. SHAS-Series, – Wireless remote control and integrated hydraulics.



364

ML, SL, SBL-SERIES, HYDRAULIC GANTRIES

Telescopic hydraulic gantries are heavy lifting systems that offer control and stability, even in confined spaces. Wireless control system is included and offer superior safety and control for your most demanding lifting and rigging operations.



368

HSK, LH-SERIES, SKIDDING SYSTEMS

A system comprised of a series of skid-shoes powered by hydraulic push-pull cylinders, traveling over a pre-constructed track. LH-Series includes low-height skid beams that can fit in tight spaces while still offering high capacity.

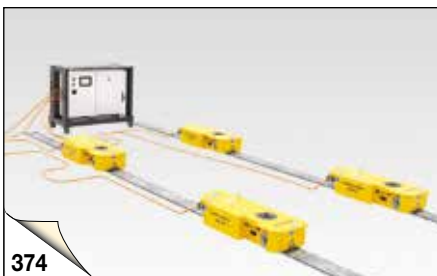

374

ETR-SERIES, ELECTRIC TROLLEY SYSTEMS

Safe & synchronized travel. The ETR-System is comprised of electrically-driven trolleys which can carry heavy loads along a fixed track system. The entire system is controlled by a hand held wireless control system.

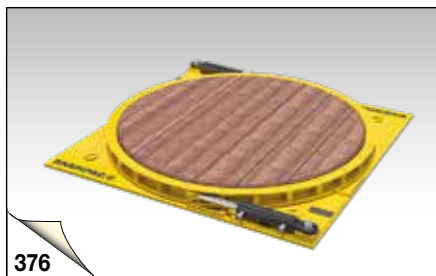

376

ETT-SERIES, HYDRAULIC TURNTABLES

Safe and controlled rotation. The ETT-Series is your solution for rotating heavy loads during, before or after a lifting and skidding operation.



377

SPMT-SELF-PROPELLED MODULAR TRANSPORTER

A trailer with a slim design to transport large and heavy objects. Hydraulic strength in a linear drive transport system.

Enerpac hydraulic pumps are available in over 1000 different configurations. Whatever your high-pressure pump needs are... speed, control, intermittent or heavy duty cycle or pumps for multiple lift point capabilities and synchronous lifting systems, you will find an Enerpac pump suited to the application.

⑦ Featuring Hand, Battery, Electric, Air and Gasoline powered models, with multiple reservoir and valve configurations, Enerpac offers the most comprehensive pump line available.



Pump Selection

For help in selecting the correct pump for your application, please view our 'Yellow Pages'. If you require further assistance, contact the Enerpac office located near you.

Page: 408



Torque Pumps

System matched air and electric pumps provide control to operate Enerpac Torque Wrenches.

Page: 273



Pumps for Multiple Lift Point Capabilities

The SFP-Series Split-Flow Pumps are an economical solution for multi-point controlled lifting and lowering applications and a far better alternative than using separately operated pumps.





















Pumps for Synchronous Lifting Systems

EVOP-Series: Each Pump-per-Point controls only one lifting point, providing the best combination of high flow rate and accuracy. The multi-functional **EVO-Series** lifting system to control 4, 8, 12 upto 48 lifting points.

Page: 343



Pumps and Directional Valves Section Overview

Power Source	Pump Types	Maximum Reservoir Capacity (litres)	Max. Flow at Rated Pressure (l/min)	Maximum Power Consumption	Series		Page
Manual	Lightweight Hand Pumps Exclusively from Enerpac	2,5	2,47 (cm ³ /stroke)	–	P		76 ▶
	ULTIMA Steel Hand Pumps	7,4	4,75	–	P		78 ▶
	Low Pressure Hand Pumps	3,3	9,50	–	P		80 ▶
	Multifluid Hand Pumps Pumping Fluids up to 1000 bar	–	20,6 (cm ³ /stroke)	–	MP		82 ▶
	Foot Pump For Hands Free Operation	0,5	2,47 (cm ³ /stroke)	–	P		83 ▶
	Ultra-High Pressure Hand Pumps Pressure up to 2800 bar	1,0	2,49 (cm ³ /stroke)	–	P, 11		84 ▶
Electric	Battery Powered Hydraulic Pumps Portable Cordless zero emission pump	2,0	0,25	0,37 (kW)	XC		86 ▶
	Battery Powered Hydraulic Pumps Cordless, zero emission pump	8,0	0,52	1,0 (kW)	ZC		88 ▶
	Economy Pump Series Compact and Portable	3,8	0,32	0,37 (kW)	PU		90 ▶
	Z-Class Pumps, ZE2-Series Durable, reliable, easy to use	6,8	0,27	0,56 (kW)	ZE2		92 ▶
	E-Pulse® Hydraulic Pumps High Productivity, Innovative Design	3,0	0,50	0,63 (kW)	E E-Pulse®		94 ▶
	Z-Class Pumps Portable Hydraulic Power	39	1,0	1,25 (kW)	ZU		98 ▶
	Z-Class Pumps Powerful and Heavy-Duty	39	2,73	5,60 (kW)	ZE		104 ▶
Air	Air Hydraulic Pumps Single and Twin-Air Motor	1,3	0,13	255 (l/min)	PA		110 ▶
		8,0	0,15	510 (l/min)	PAM		111 ▶
	Turbo II Air Hydraulic Pumps Compact Air Over Hydraulic	5,0	0,16	340 (l/min)	PATG		112 ▶
	Air Hydraulic Foot Pumps For Productivity and Ergonomics	2,0	0,25	991 (l/min)	XA		114 ▶
	Z-Class Air Hydraulic Pumps Modular Air Pumps	39	1,31	2840 (l/min)	ZA		116 ▶
Gasoline	Z-Class Gasoline Hydraulic Pumps Gas Powered High Flow Pumps	39	1,64	4,8 (kW)	ZG5		118 ▶
	Z-Class Gasoline Hydraulic Pumps Gas Powered High Flow Pumps	39	3,30	9,7 (kW)	ZG6		118 ▶
Directional Control Valves Manual and Solenoid Valves, pump and remote mounted					VM, VE VC		121 ▶

▼ Shown from top to bottom: P802, P842, P202, P142



- Lightweight and compact design
- Durable glass-filled nylon reservoir and nylon encapsulated aluminium pump base for maximum corrosion resistance
- Two-speed operation reduces handle strokes by as much as 78% over single speed pumps
- Lower handle effort to minimize operator fatigue
- Integral 4-way valve on P842 for operation of double-acting cylinders
- Handle lock and lightweight construction for easy carrying
- Large oil capacities to power a wide range of cylinders or tools
- Non-conductive fiberglass handle for improved operator safety
- Internal pressure relief valve for overload protection.

▼ Cylinder-pump set SCR254H used to support the construction while monitoring pressure and load with the gauge.



Exclusively from Enerpac



Cylinder Matching Chart

For help in selecting the correct hand pump for your application, please refer to the Cylinder Matching Chart located in the 'Yellow Pages'.

Page: 408



Speed Chart

To determine how a specific pump will operate your cylinder, see the Pump-Cylinder Speed Chart in the 'Yellow Pages'.

Page: 415



Tank Kits:

When a return-to-tank port is required, the Tank Kits provide a 7/16"-20 UN port at the rear of the reservoir.

PC20	Fits P141, P142
PC25	Fits P202, P391, P392



Power Box

Portable tool box with P392 hand pump, gauge adaptor assembly, hose and RC-, RCS, RSM-or WR-Serie cylinder.

Page: 65

Pump Type	Usable Oil Capacity (cm ³)	Model Number	Pressure Rating ²⁾ (bar)		Oil Displacement per Stroke (cm ³)		Max. Handle Effort (kg)
			1 st stage	2 nd stage	1 st stage	2 nd stage	
Single-Speed	327	P141	-	700	-	0,90	32,7
	901	P391	-	700	-	2,47	38,6
Two-Speed	327	P142 ¹⁾	13	700	3,62	0,90	35,4
	901	P202	13	700	3,62	0,90	28,6
	901	P392 ¹⁾	13	700	11,26	2,47	42,2
	2540	P802	27	700	39,33	2,47	43,1
	2540	P842 ³⁾	27	700	39,33	2,47	43,1

¹⁾ Available as set, see note on next page. P392 also available in Power Box Set (page 65).

²⁾ Contact Enerpac for applications where operating pressure is less than 10% of pressure rating.

³⁾ P842 for use with double-acting cylinders

Lightweight Hand Pumps

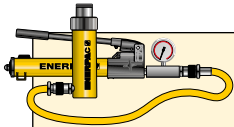

Pump-Cylinder Sets

All pumps marked with an * are available as sets (pump, cylinder, gauge, couplers and hose) for your ordering convenience.

Page: 62

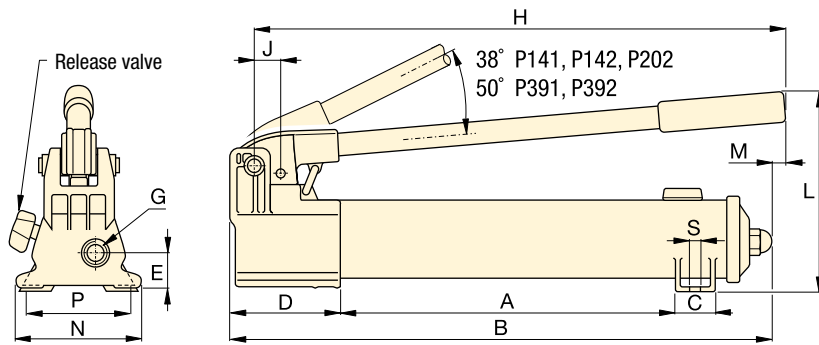

P141, P142, P202, P391, P392

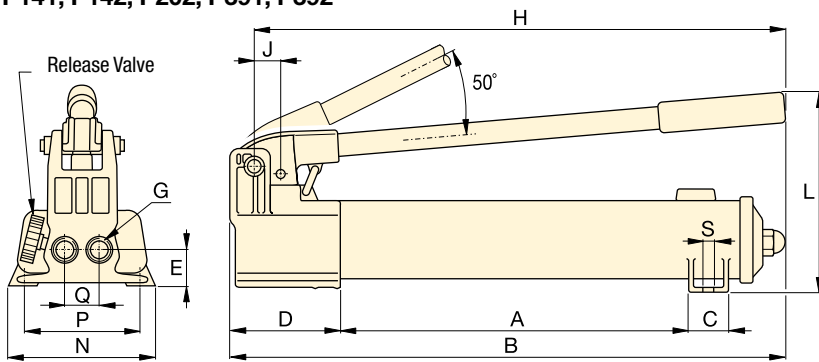

P802

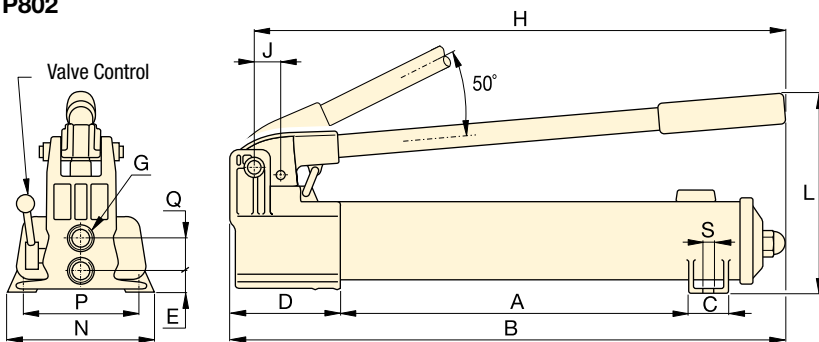

P842

P Series



Reservoir Capacity:

327 - 2540 cm³

Flow at Rated Pressure:

0,90 - 2,47 cm³/stroke

Operating Pressure:

700 bar



Hoses

Enerpac offers a complete line of high quality hydraulic hoses. To ensure the integrity of your system, specify only genuine Enerpac hydraulic hoses.

Page: 128



GA45GC Gauge Adaptor

Protect yourself from system overloading by simply ordering one part number for a pre-assembled gauge, adaptor block and coupler.

Page: 142



Foot Pump P392FP

For handsfree operation the lightweight and robust P392FP Foot Pump is the perfect choice.

Page: 83

Piston Stroke	Dimensions (mm)															(kg)	Model Number
	(mm)	A	B	C	D	E	G	H	J	L	M	N	P	Q	S		
12,7	185	336	28	85	28	1/4"-18 NPTF	319	19	143	-	95	80	-	7	2,4	P141	
25,4	344	533	36	99	33	3/8"-18 NPTF	522	30	177	16	120	-	-	-	4,1	P391	
12,7	185	336	28	85	28	1/4"-18 NPTF	319	19	143	-	95	80	-	7	2,4	P142 ¹⁾	
12,7	344	509	36	85	28	1/4"-18 NPTF	400	19	144	16	95	-	-	-	3,4	P202	
25,4	344	533	36	99	33	3/8"-18 NPTF	522	30	177	16	120	-	-	-	4,1	P392 ¹⁾	
25,4	337	552	45	133	35	3/8"-18 NPTF	527	30	228	-	181	153	35	10	8,2	P802	
25,4	337	552	45	133	20	3/8"-18 NPTF	527	30	228	-	181	153	36	10	10,0	P842 ³⁾	

▼ Shown from left to right: P77, P80, P84, P801, P39



- Reduced handle effort and ergonomic grip for less operator fatigue
- Two-speed operation for fast and easy operation (except P39)
- Vent free reservoir eliminates spills
- Quick grip handle allows for easy transport
- Integral reservoir over-pressurization protection
- All steel construction, chrome plated plunger and wiper system for durable, long lasting performance
- 4-way valving on the P84 and P464 for operation of double-acting cylinders.

▼ In the absence of a power supply, the P80 Hand Pump offers a powerful solution.



The Solution for Tough Jobs



Two Speed Pumps

Recommended for applications where cylinder plunger must advance rapidly to load contact, and applications where greater oil capacities are required, such as multiple cylinder hook-ups.



Foot Pump Conversion Kits

Convert your P39, P77, P80 or P801 to foot power with the PC11 Kit. Includes instructions for easy conversion.



GA45GC Gauge Adaptor

Protect yourself from system overloading by simply ordering one part number for a pre-assembled gauge, adaptor block and coupler.

Page: 142



4-Way Control Valve

P84 and P464 feature a manual 4-way control valve, designed for use with one double-acting or two single-acting cylinders. For system

set-up information:

Page: 410

Pump Type	Usable Oil Capacity (cm ³)	Model Number	Pressure Rating ²⁾ (bar)		Oil Displacement per Stroke (cm ³)		Max. Handle Effort (kg)
			1 st stage	2 nd stage	1 st stage	2 nd stage	
Single	672	P39	-	700	-	2,46	39
Two-Speed	672	P77	34	700	16,39	2,46	40
	2200	P80 ¹⁾	34	700	16,39	2,46	35
	4100	P801	34	700	16,39	2,46	35
	2200	P84 ³⁾	34	700	16,39	2,46	35
	7423	P462	14	700	126,20	4,75	49
	7423	P464 ³⁾	14	700	126,20	4,75	49

¹⁾ Available as a set, see note on next page.

²⁾ Contact Enerpac for applications where operating pressure is less than 10% of pressure rating.

³⁾ P84 and P464 are for use with double-acting cylinders.



Speed Chart

To determine how a specific pump will operate your cylinder, see the Pump-Cylinder Speed Chart in the 'Yellow Pages'.

Page: 415

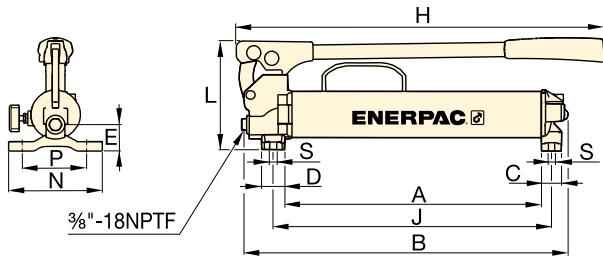

P39, P77

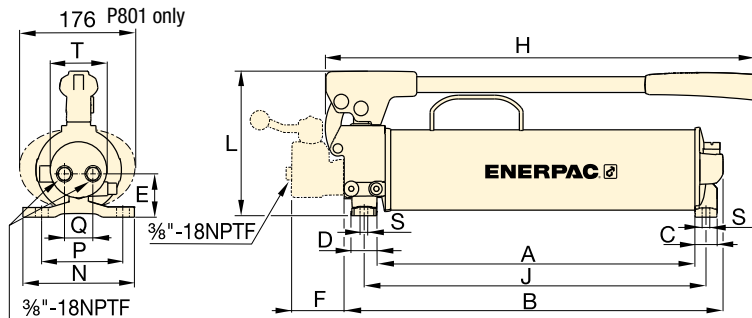

P80, P801, P84

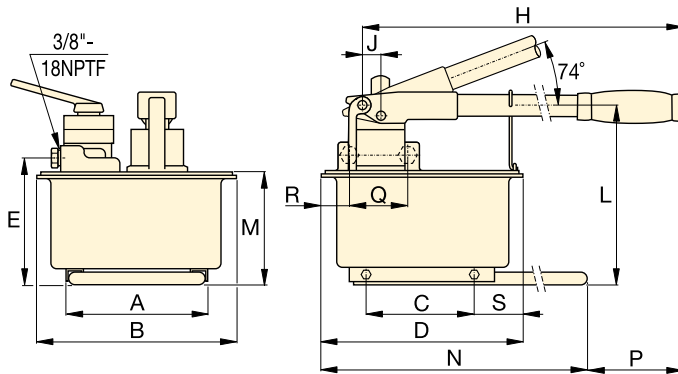

P462, P464

P Series



Reservoir Capacity:

672 - 7423 cm³

Flow at Rated Pressure:

2,46 - 4,75 cm³/stroke

Maximum Operating Pressure:

700 bar



Extra Capacity Hand Pumps

P462 and P464 feature extra large reservoirs and high first-stage flow rate. These pumps are ideally suited for powering high-capacity cylinders.

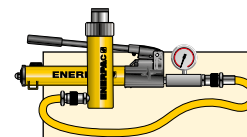

Pump-Cylinder Sets

The **P80** is also available as **complete set** (pump, cylinder, gauge, couplers and hose) for your ordering convenience.

Page: 62



Cylinder Matching Chart

For help in selecting the correct hand pump for your application, please refer to the Cylinder Matching Chart located in the 'Yellow Pages'.

Page: 408

Piston Stroke	Dimensions (mm)																Model Number	
	(mm)	A	B	C	D	E	F	H	J	L	M	N	P	Q	R	S		T
25,4	383	480	30	35	37	-	550	416	163	-	140	111	-	-	8,4	-	6,2	P39
25,4	391	487	30	35	47	-	550	424	163	-	140	111	-	-	8,4	-	7,1	P77
25,4	428	511	30	35	55	-	579	460	195	-	150	121	42	-	8,4	74	10,7	P80¹⁾
25,4	428	511	30	35	55	-	579	460	195	-	150	121	42	-	8,4	74	14,1	P801
25,4	428	510	30	35	55	70	579	460	195	-	150	121	38	-	8,4	74	11,8	P84³⁾
38,1	210	308	163	320	195	-	671	25	270	175	650	92	-	-	80	-	27,7	P462
38,1	210	308	163	320	195	-	671	25	270	175	650	92	89	68	80	-	27,7	P464³⁾

▼ Shown from left to right: P25, P51, P18



When Less Than 700 bar is All You Need



GA45GC Gauge Adaptor

Protect yourself from system overloading by simply ordering one part number for a pre-assembled gauge, adaptor block and coupler.

Page: 142



Hoses

Enerpac offers a complete line of high quality hydraulic hoses. To ensure the integrity of your system, specify only genuine Enerpac hydraulic hoses.

Page: 128

- P25 and P50 pump oil in both forward and reverse handle movement improving overall efficiency, ideal when mounting space is restricted
- External load-release valve
- Internal pressure-relief valve for overload protection
- For use with single-acting cylinders and tools
- P18 vertical operation requires pump head facing down
- P25 and P50 vertical operation requires pump vent side facing down
- P51 for horizontal operation only.

▼ P18 hand pump used for locking the rotating table for marble polishing.



Pump Type	Usable Oil Capacity (cm ³)	Model Number *	Pressure Rating (bar)	Oil Displacement per Stroke (cm ³)	Max. Handle Effort (kg)
Single-Speed	360	P18	200	2,46	16
	3277	P25	175	9,50	27
	3277	P50	350	4,75	27
	819	P51	200	4,10	27

* For use with single-acting cylinders and tools

Low Pressure Hand Pumps

P Series



Reservoir Capacity:
360 - 3277 cm³

Flow at Rated Pressure:
2,46 - 9,50 cm³/stroke

Maximum Operating Pressure:
175 - 350 bar

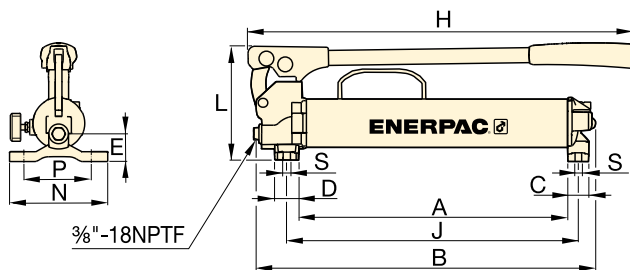

P18

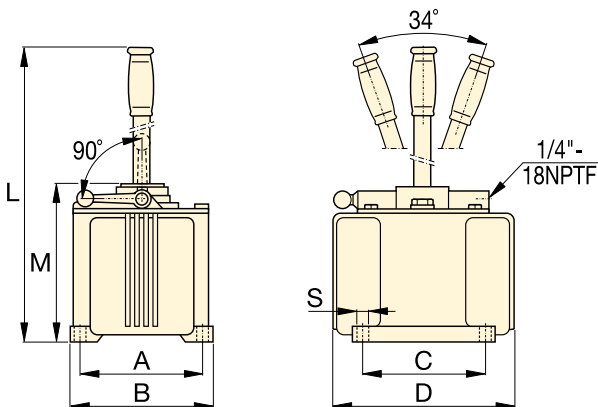

P25, P50

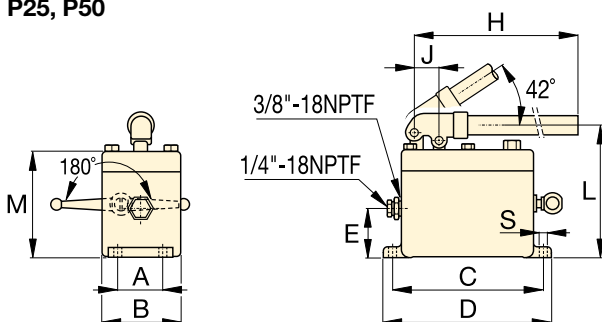

P51



MP-Series Multifluid Hand Pumps

Corrosion resistant hand pumps for low pressure filling and high pressure testing applications, suitable for a wide range of fluids.

Page: 82

▼ P51 hand pumps used with RC-series cylinders to keep wooden layers under pressure during lamination of plates.



Piston Stroke	Dimensions (mm)												Model Number *
	(mm)	A	B	C	D	E	H	J	L	M	N	S	
25,4	221	316	30	35	37	385	254	163	-	140	8,4	5,0	P18
38,1	152	173	152	240	-	-	-	684	200	-	10	16,3	P25
38,1	152	173	152	240	-	-	-	684	200	-	10	16,8	P50
25,4	52	92	181	200	57	610	29	160	129	-	9	5,4	P51

▼ MP110



- Superior corrosion resistance
- Standard Nitrile seals – can be used for a wide range of fluids such as demineralised water, oil/water emulsions, waterglycols, mineral oils
- Two speed pumps up to 1000 bar pressure
- Buna Nitrile seals can be exchanged with optional EPDM seal for use with Skydrol or brake fluids
- Impregnated aluminium anodized pump housing with stainless steel internal pumping components
- Externally adjustable pressure relief valve
- 1/4" NPTF gauge port
- For use with single-acting cylinders and tools.

MP Series

Flow at Rated Pressure:

1,6 - 20,6 cm³/stroke

Maximum Operating Pressure:

110 - 1000 bar



Optional Reservoir Kit

Includes 10 litres tank with skid frame, top plate with reservoir seal, suction pipe and mounting bolts. Useable oil capacity is 7,4 litres. Order modelnr.: **MP10T**.



Stainless Steel Hand Pump

Also available as stainless steel hand pump, model number **11-400**.

Page: **84**

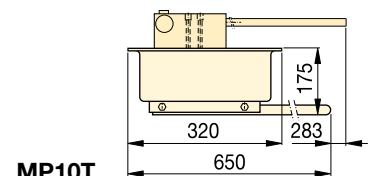
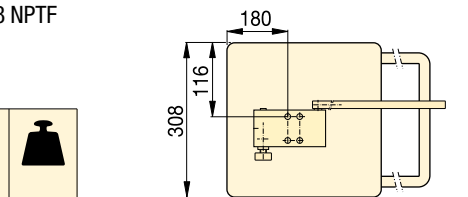
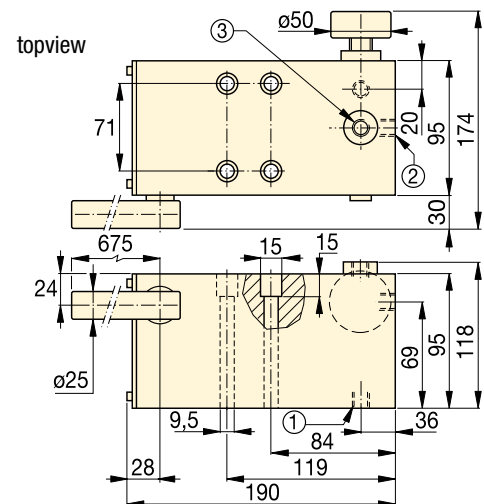

MP110, 350, 700, 1000

- ① Suction / Tank return port 3/8"-18 NPTF
- ② Pressure port 3/8"-18 NPTF
- ③ Gauge port 1/4"-18 NPTF

Pump Type	Usable Oil Capacity * (cm ³)	Model Number **	Pressure Rating (bar)		Oil Displacement per Stroke (cm ³)		Max. Handle Effort (kg)	Piston Stroke (mm)	Weight (kg)
			1st stage	2nd stage	1st stage	2nd stage			
Two Speed	*	MP110	35	110	52,6	20,60	45	27,1	6,6
	*	MP350	35	350	52,6	7,15	45	27,1	6,6
	*	MP700	35	700	52,6	2,63	45	27,1	6,6
	*	MP1000	35	1000	52,6	1,60	45	27,1	6,6

* MP-Pump includes 1,5 mm thick gasket for reservoir mounting. MP-Series pumps requires the use of an external reservoir.

** MP-Series pumps are for use with single-acting cylinders and tools.

Lightweight Hydraulic Foot Pump

▼ P392FP



- Robust, durable and compact
 - Steel frame for maximum stability
 - Steel pumping handle
 - Aluminium reservoir
- Foot pedal lock and lightweight construction for easy carrying
- Two-speed operation reduces foot pedal strokes
- Large foot-pad release valve for controlling load descent
- Internal pressure relief valve for overload protection.

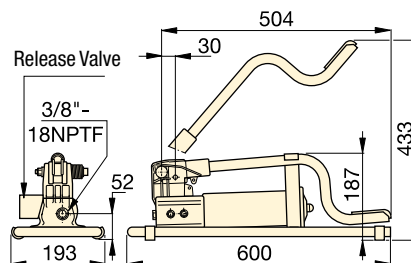

Usable Oil Capacity (cm ³)	Model Number	Pressure Rating (bar)		Oil Displacement per Stroke (cm ³)		Max. Handle Effort (kg)	Piston Stroke (mm)	Pump Weight (kg)
		1st stage	2nd stage	1st stage	2nd stage			
492	P392FP *	15	700	11,26	2,47	42	25,4	7,0

* Available as set, see note on this page.

P Series



Reservoir Capacity:

492 cm³

Flow at Rated Pressure:

2,47 cm³/stroke

Maximum Operating Pressure:

700 bar

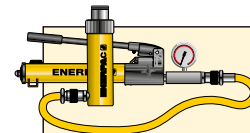

Pump-Cylinder Sets

The P392FP is available as set (pump, cylinder, gauge, couplers and hose) for your ordering convenience.

Page: 62



Hoses

Enerpac offers a complete line of high quality hydraulic hoses. To ensure the integrity of your system, specify only genuine Enerpac hydraulic hoses.

Page: 128

▼ P392FP offers the advantage of hands free operation to handle and control the tool or cylinder.



P, 11-Series, Ultra-High Pressure Hand Pumps **ENERPAC**

▼ Shown from left to right: 11-100, P2282



- Two-speed operation on the P2282 allows for faster fill operation, reducing cycle times for many testing applications
- 303 Stainless steel construction on the 11-100 and 11-400 models enable use with many different fluids, such as distilled water, diesters, silicones, soluble oils and petroleum
- Large release knob for improved control of pressure release
- Outlet ports are 3/4"-16 cone for 2800 bar rating
- Ultra-high pressure fittings feature all stainless steel construction except adaptor 41-366 which features nickel plated carbon steel construction.

Cone Seal

Stainless Steel High Pressure fittings seal on a 'cone' surface and do not require pipe sealer. The Gland Nut holds the sleeve and tubing tight against the cone surface to provide a 2800 bar seal.

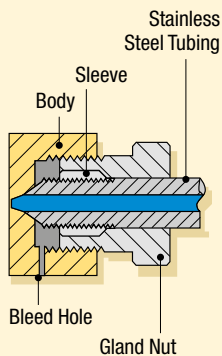

Ultra-High Pressure up to 2800 bar



2-Way Shut-Off Valve Model Number 72-750

For 2800 bar applications requiring a shut-off valve or gauge snubber. Made of 318 Stainless Steel and utilizing .38 inch cone fittings, it is the perfect selection for use with your ultra-high pressure hand pump.



Test System Gauges

Ideal for monitoring pressure in your hydraulic circuit. Test System Gauges, such as the T6010L, are available with cone threads or NPTF threads and a variety of pressure ranges.

Page: 140

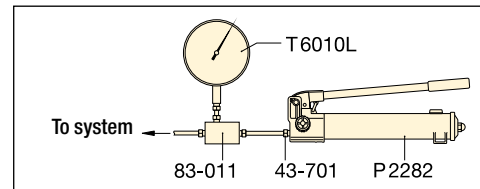

▲ Typical Test System

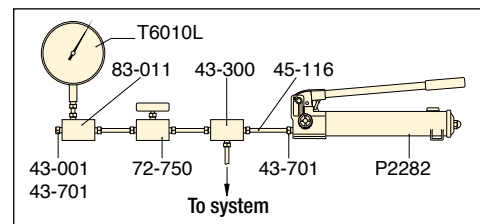

▲ Test System with Gauge and Snubber

Pump Type	Usable Oil Capacity (cm ³)	Model Number	Pressure Rating * (bar)		Oil Displacement per Stroke (cm ³)		Max. Handle Effort (kg)
			1 st stage	2 nd stage	1 st stage	2 nd stage	
Two-Speed	983	P2282	13	2800	16,22	0,61	48,1
Single-Speed	737	11-100	-	700	-	2,49	54,4
	737	11-400	-	2800	-	0,62	54,4

* Contact Enerpac for applications where operating pressure is less than 10% of operating pressure.

Ultra-High Pressure Hand Pumps

▼ Optional Ultra-High Pressure Fittings and Tubings

Description	Connection	Model Nr.
2800 bar		
Gland Nut Plug	.38" cone	43-001
Elbow	.38" cone	43-200
Tee	.38" cone	43-300
Gauge Tee	.38" cone side/ .25" cone gauge port	43-301
Gauge Adaptor	.38" cone side/ .25" cone gauge port	83-011
Coupling	.38" cone	43-400
Cross	.38" cone	43-600
Gland Nut with Sleeve	.38" cone	43-701
Gauge Connector	.25" cone	43-704
Tubing	100 mm tube, O.D. .38" * 200 mm tube, O.D. .38" * 300 mm tube, O.D. .38" *	45-116 45-126 45-136
700 bar only		
Adaptor	.38" F cone to 1/4" M NPTF	41-146
	.38" F cone to 3/8" M NPTF	41-166
Adaptor	.38" F cone to 1/4" F NPTF	41-246
	.38" F cone to 3/8" F NPTF	41-266
Adaptor	.38" M cone to 3/8" F NPTF	41-366

Note: .25" cone fittings use 9/16"-18 threads, 3/8" cone fittings use 3/4"-16 threads.
* Actual tubing lengths are 19 mm less than nominal size shown. These dimensions make distance between centers of valves and fittings multiples of 100 mm spaces.

P 11 Series



Reservoir Capacity:
737 - 983 cm³

Flow at Rated Pressure:
0,61 - 2,49 cm³/stroke

Maximum Operating Pressure:
700 - 2800 bar



Ultra-High Pressure pumps DO NOT have an internal safety pressure relief valve.



Stainless Steel Construction

Ultra-high Pressure Fittings feature all stainless steel construction except adaptor **41-366**, which features nickel plated carbon steel construction.

11-100
11-400

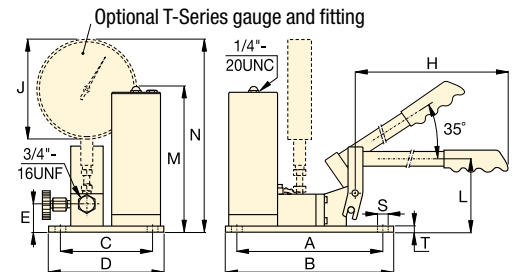

P2282

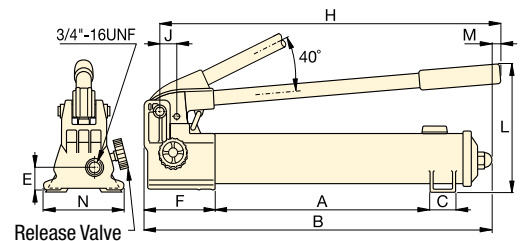

Piston Stroke (mm)	Dimensions (mm)														(kg)	Model Number
	A	B	C	D	E	F	H	J	L	M	N	S	T			
25,4	344	558	35	–	31	133	527	29	228	7	120	–	–	6,4	P2282	
19,8	240	266	151	177	45	–	635	162	114	237	314	7	9	10,0	11-100	
19,8	240	266	151	177	45	–	635	162	114	237	314	7	9	10,0	11-400	

▼ XC1201ME



- Cordless, zero emission pump
- Lightweight design with integrated handle and carrying strap for portability
- Bladder reservoir prevents contamination and allows pump usage in any position
- Powerful 0,37 kW motor and 28 Volt Lithium-Ion battery deliver exceptional speed and superior run time
- High-strength fiberglass reinforced composite shroud for superior durability in demanding job site environments
- Cordless technology eliminates tripping hazards found in other electric or air powered pumps
- Three valve options for single- and double-acting cylinders: 3-way/2-position, 4-way/3-position or Dump & Hold
- Also available as torque pumps.



Performance of a Powered Pump Portability of a Hand Pump



Interactive Pendant on XC-1302S Models

Available only on XC1302S pump models. The interactive pendant allows user to easily toggle from "jog operation" to "dump system pressure" with a push of a button. (Cord length is 3 metres).



28-Volt Battery

The XC28V with Lithium-Ion technology for maximum battery performance and superior run time.



Roll Cage

Optional Roll Cage XC-Series pumps. Please order model number XCRCTK.



GA45GC Gauge Adaptor Assembly

Protect yourself from system overloading by simply ordering one part number for a pre-assembled gauge, adaptor block and coupler.

Page: 142

◀ Portable power and simplicity for the toughest jobs.



XC-Series Cordless Pumps

The XC-Series cordless pump is ideal for jobs that require a combination of portability, speed, and safety. These cordless pumps are perfect for remote locations without access to power, but also indoors where trip hazards, ergonomics or size is a concern.

The XC-Series cordless pump is compatible with most Enerpac hydraulic tools and small to medium sized cylinders. The XC-Series cordless pump is CSA and CE compliant.

Lithium-Ion battery for superior run time:

- 279 cuts of 10 mm reinforcing bar using a WHC750 Cutter
- 112 lifts with a WR5 Spreader
- 44 splits on M27 - 8.8 nuts using a NC3241 Nut Cutter
- 28 times lifting with a RC104 cylinder (10 ton, 100 mm stroke).

Note: Actual number of cycles per charge will vary depending on condition of battery, tool and ambient conditions. Battery life with double-acting tools is approximately 75% of that for comparable, single-acting tools.



XC Series



Reservoir Capacity:
1,0 - 2,0 litres

Flow at Rated Pressure:
0,25 l/min

Maximum Operating Pressure:
700 bar

- ① Outlet "Advance" Port 3/8"-18 NPTF
- ② Oil Fill (must use funnel)
- ③ User Adjustable Relief Valve Access Port
- ④ Directional Control Valve *
- ⑤ Shoulder Strap Connection Points
- ⑥ Safety Lock Feature *
- ⑦ On/Off Switch
- ⑧ Inlet "Retract" Port (double-acting models only)

* On single-acting (XC12) and double-acting (XC14) models only.

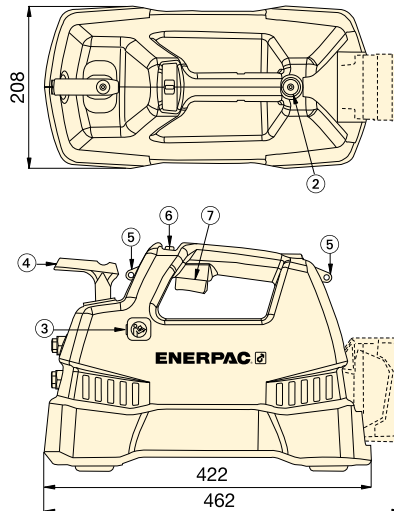
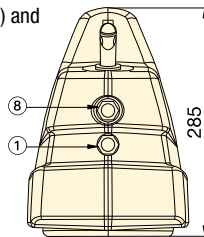

SELECTION CHART

Pump Type (Used with cylinder)	Useable Oil Capacity (litres)	Model Number	Output Flow Rate (l/min)			Valve Function	Charger Voltage (VAC)	Weight (kg)
			No Load	140 bar	700 bar			
Single-Acting	1,0	XC1201MB ¹⁾	2,05	0,49	0,25	3-way, 2-pos.	115	10,0
	2,0	XC1202MB	2,05	0,49	0,25	3-way, 2-pos.	115	11,0
	1,0	XC1201ME ¹⁾	2,05	0,49	0,25	3-way, 2-pos.	230	10,0
	2,0	XC1202ME	2,05	0,49	0,25	3-way, 2-pos.	230	11,0
	1,0	XC1201M ²⁾	2,05	0,49	0,25	3-way, 2-pos.	-	10,0
	2,0	XC1202M ²⁾	2,05	0,49	0,25	3-way, 2-pos.	-	11,0
Single-Acting	2,0	XC1302SB	2,05	0,49	0,25	Dump and Hold	115	11,4
	2,0	XC1302SE	2,05	0,49	0,25	Dump and Hold	230	11,4
	2,0	XC1302S ²⁾	2,05	0,49	0,25	Dump and Hold	-	10,2
Double-Acting	1,0	XC1401MB	2,05	0,49	0,25	4-way, 3-pos.	115	10,0
	2,0	XC1402MB	2,05	0,49	0,25	4-way, 3-pos.	115	11,0
	1,0	XC1401ME	2,05	0,49	0,25	4-way, 3-pos.	230	10,0
	2,0	XC1402ME	2,05	0,49	0,25	4-way, 3-pos.	230	11,0
	1,0	XC1401M ²⁾	2,05	0,49	0,25	4-way, 3-pos.	-	10,0
	2,0	XC1402M ²⁾	2,05	0,49	0,25	4-way, 3-pos.	-	11,0

¹⁾ Available as a cylinder pump set, see page 62.

²⁾ Batteries and charger not included.

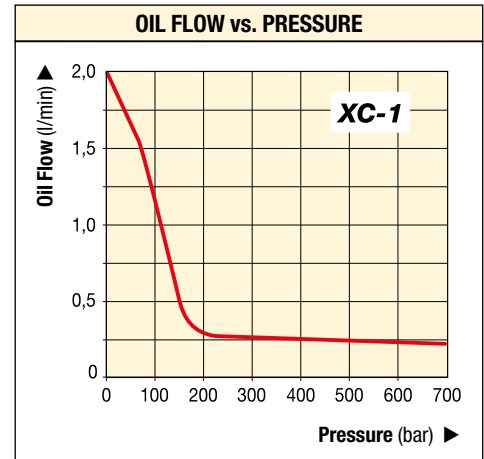

Take the battery pump anywhere without power cords or air hoses.



▼ ZC3308JE



Productivity, Performance, Safety

- High-flow cordless solution saves users time and money by eliminating the need for using a generator and extension cords
- Brushless 1,0 kW motor and 3 stage pump maximizes pump and tool productivity while minimizing heat buildup and downtime
- The Lithium-Ion battery provides superior run time, even under extreme job site conditions
- Convenient 3 m pendant cord for hassle-free operation
- Reduced noise level 80 dBA max.
- Zero emission hydraulic power pack.



Z Tough.
Dependable.
Innovative.
CLASS

High-Performance Battery Power



Charger *

ZC115VC	120 V - 60 Hz
ZC230VC	230 V - 50 Hz

Battery **

ZC82V4NA	82 V, 4 Ah
ZC82V4EUAU	82 V, 4 Ah

* 1-hour quick charger

** NA is North America and EUAU is European and Australia.



Gauges

Minimize the risk of overloading and ensure long, dependable service from your equipment. Refer to the System Components

Section for a full range of gauges.

Page: 127



Hoses

Enerpac offers a complete line of high quality hydraulic hoses. To ensure the integrity of your system, specify only Enerpac

hydraulic hoses.

Page: 128

◀ Special Enerpac ZC-Series Cordless Hydraulic Pump used for rail stressing applications (page 198).



ZC-Series, Cordless Pumps

The Enerpac ZC-Series pump combines the performance of an electric pump with the convenience and portability of a battery pump. This quiet, cordless solution is ideal for applications where emission and noise are a concern, or when electricity or air is not readily available.

The Lithium-Ion battery provides impressive run times

Power for the pump is supplied by a rechargeable 82V lithium-ion battery.

The lithium-ion battery is capable of providing impressive run times, even under extreme job site conditions.

- 50 times lifting with RC1006 cylinder (95 ton, 168 mm stroke)
- 90 times lifting with RC504 cylinder (50 ton, 101 mm stroke).

Valve Options

- 4-way/3-position manual control valve used with double-acting cylinders
- 3-way/3-position manual control valve used with single-acting cylinders
- 4-way/3-position manual control valve with locking and power seat functions used in post tensioning concrete applications.

Applications

- High-flow cordless solution for industrial applications
- Foundation repair
- Rail industry
- Post-tensioning concrete.

ZC Series



Reservoir Capacity:

8 litres

Flow at Rated Pressure:

0,52 l/min

Motor Size:

1,0 kW

Maximum Operating Pressure:

700 bar

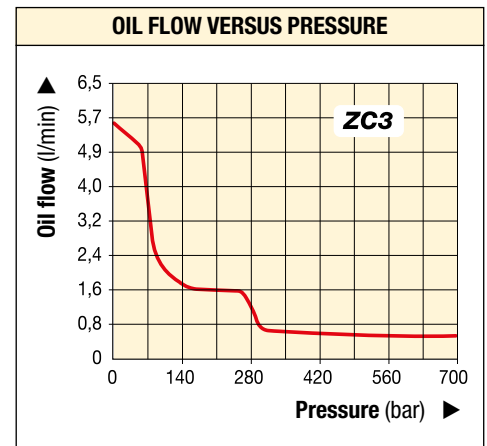
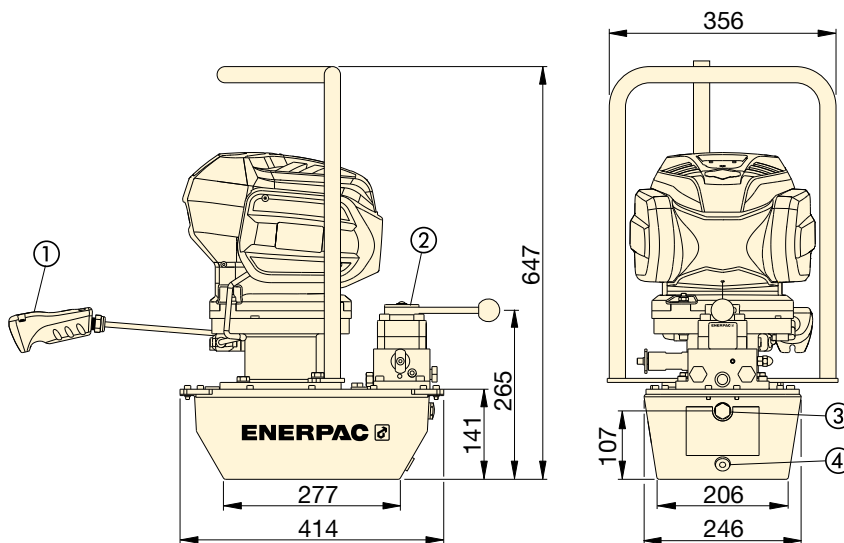

- ① Motor On/Off Remote Pendant
- ② VM43-LPS Valve Shown
- ③ Sight Glass
- ④ Oil Drain ½" NPTF

Used for Cylinder or Tools	Useable Oil Capacity (litres)	Manual Valve Model Number	Valve Function	Model Number *	Output Flow Rate (l/min)			Battery Charger Voltage V - Hz	** (kg)
					< 70 bar	< 275 bar	< 700 bar		
Single-Acting	6,6	VM33	Advance/Neutral/Retract	ZC3308JB	5,0	1,3	0,52	115 - 60	29,7
				ZC3308JE				230 - 50	
Double-Acting	6,6	VM43	Advance/Neutral/Retract	ZC3408JB	5,0	1,3	0,52	115 - 60	29,7
				ZC3408JE				230 - 50	
Power Seater Post-Tensioning Tools	6,6	VM43LPS	Advance/Hold/Retract	ZC3908JB	5,0	1,3	0,52	115 - 60	33,3
				ZC3908JE				230 - 50	

* All models meet CE safety requirements and all TÜV requirements. Pump includes one charger and battery.

** Weight including oil and battery. Battery weight = 2,6 kg.

▼ PUJ1200E



Heavy on Performance, Light on Weight

- **Lightweight and compact design: 11,8 to 18,6 kg**
- **Large easy-carry handle for maximum portability**
- **Two-speed operation reduces cycle times for improved productivity**
- **230 VAC 50/60-cycle universal motor will operate under poor voltage supply**
- **24 VAC remote motor control, 3 m length for operator safety**
- **Starts under full load**
- **High strength molded shroud, with integral handle, protects motor from contamination and damage**
- **Designed for intermittent duty cycle.**

▼ An Economy Pump PUJ1200E is used with a low-height cylinder RCS302 to reposition a Scissor lift to simplify maintenance.



Gauges

Minimize the risk of overloading and ensure long, dependable service from your equipment.

For use with the Economy pump the **G2535L** gauge and **GA3** gauge adaptor are suggested.

For a full range of gauges, please refer to the System Components section.

Page: 138



Hoses

Enerpac offers a complete line of high quality hydraulic hoses. To ensure the integrity of your system, specify only genuine Enerpac hydraulic hoses.

Page: 128



Speed Chart

To determine how a specific pump will operate your cylinder, see the Pump-Cylinder Speed Chart in the 'Yellow Pages'.

Page: 415

Pump Type (Used with cylinder)	Usable Oil Capacity (litres)	Model Number *	Pressure Rating (bar)	
			1 st stage	2 nd stage
Single-Acting	1,9	PUD1100E	13	700
	3,8	PUD1101E	13	700
	1,9	PUJ1200E	13	700
	3,8	PUJ1201E	13	700
	1,9	PUD1300E	13	700
	3,8	PUD1301E	13	700
Double-Acting	1,9	PUJ1400E	13	700
	3,8	PUJ1401E	13	700

* For 115 volt applications replace 'E' suffix with 'B'.

** Electric dump valve for auto-retract of cylinders.



About the Economy Pump

The Economy pump is best suited to power small to medium size cylinders or hydraulic tools. Its lightweight and compact design make it ideal for applications which require easy transport of the pump. The universal motor works well on long extension cords or generator-driven electrical power supplies.

For further application assistance refer to the 'Yellow Pages'.

PUD1100 Series

- Provides advance-retract of single-acting cylinders
- Ideal for punching applications
- For applications not requiring load holding
- 3 m cord with pendant controls motor and valve operation.

PUD1300 Series

- Provides advance-hold-retract of single-acting cylinders
- Ideal for applications requiring load-holding
- For applications requiring solenoid valve operations
- 3 m cord with pendant controls motor and valve operation.

PUJ-Series

- Manual valves provide advance-hold-retract tool operation
- Available with 3- and 4-way valves for single or double-acting cylinders
- 3 m cord with pendant controls the motor operation.



Page: 404

PU Series



Reservoir Capacity:

1,9 - 3,8 litres

Flow at Rated Pressure:

0,32 l/min

Motor Size:

0,37 kW

Maximum Operating Pressure:

700 bar

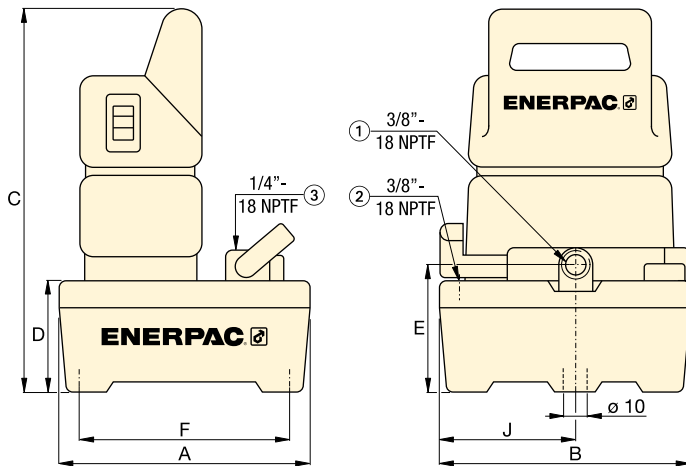

- ① Oil Outlet Port
- ② Tank Port
- ③ Gauge Port (PUJ1200 and PUJ1201 models only)

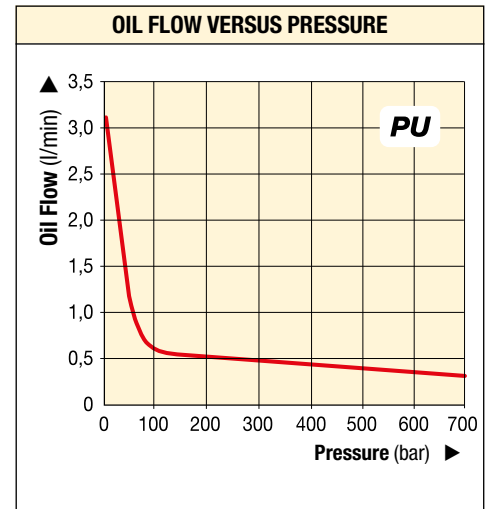

Output Flow Rate (l/min)		Valve Type	Valve Function	Current Draw (Amps)	Motor Voltage (VAC)	Sound Level (dBA)	Dimensions (mm)							Model Number *	
1 st stage	2 nd stage						A	B	C	D	E	F	J		(kg)
3,31	0,32	Dump**	Advance/Retract	3,2	230	85	244	244	362	101	119	203	133	11,8	PUD1100E
3,31	0,32			3,2	230	85	368	309	373	105	130	323	142	17,2	PUD1101E
3,31	0,32	3/2 manual	Advance/ Hold/Retract	3,2	230	85	244	244	362	101	119	203	133	10,0	PUJ1200E
3,31	0,32			3,2	230	85	368	309	373	105	130	323	142	15,4	PUJ1201E
3,31	0,32	3/2 solenoid	Dump & Hold	3,2	230	85	244	244	362	101	119	203	133	12,0	PUD1300E
3,31	0,32			3,2	230	85	368	309	373	105	130	323	142	17,5	PUD1301E
3,31	0,32	4/3 manual	Advance/ Hold/Retract	3,2	230	85	244	244	362	101	119	203	133	13,2	PUJ1400E
3,31	0,32			3,2	230	85	368	309	373	105	130	323	142	18,6	PUJ1401E

▼ ZE2208ME, ZE2-Series, Electric Pump



- 0,56 kW induction motor for long life and quiet operation
- 71 to 79 dBA across the pressure range
- 6,8 liter, steel reservoir offers capacity and cool operation for wide range of applications
- IP54 protection
- Heavy duty bearings extend pump life by reducing heat, improving lubrication and reducing wear
- Replaceable piston check valves increase service life of major pump components
- VE32D solenoid dump valve model available
- Pendant and manual control options for ease of use.

Durable, reliable, easy to use



Gauges

Minimize the risk of overloading and ensure long, dependable service from your equipment. Refer to the System Components

Section for a full range of gauges.

Page: 127



Hoses

Enerpac offers a complete line of high quality hydraulic hoses. To ensure the integrity of your system, specify only Enerpac hydraulic hoses.

Page: 128



Speed Chart

To determine how a specific pump will operate your cylinder, see the Pump-Cylinder Speed Chart in the 'Yellow Pages'.

Page: 415





ZE2-Series, Electric Pumps

The ZE2-Series is part of the proven Enerpac ZE-Series and utilizes many of the same design elements as the larger pumps in the family.

The 0,56 kW induction motor enables productive flow rates, long cycle life and quiet operation. Combined with the efficient, robust and easy to service pumping element the ZE2 is ideal for manufacturing and shop environments.

Multiple valve and control options provide the flexibility to match the pump to a wide range of pressing, punching and other operations.

Compare the ZE2 to the other pumps in the ZE-Series and determine the best pump for the application.

ZE2 Series



Reservoir Capacity:

6,8 litres

Flow at Rated Pressure:

0,27 l/min

Motor Size:

0,56 kW

Maximum Operating Pressure:

700 bar

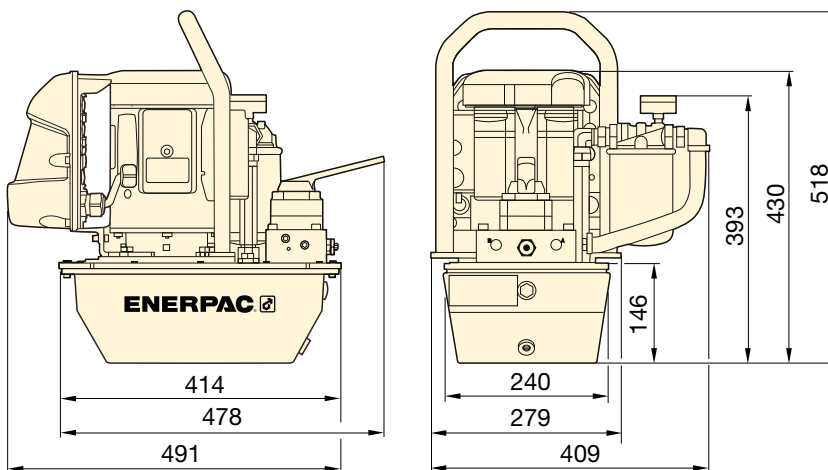

ZE2 with Optional Return Line Filter

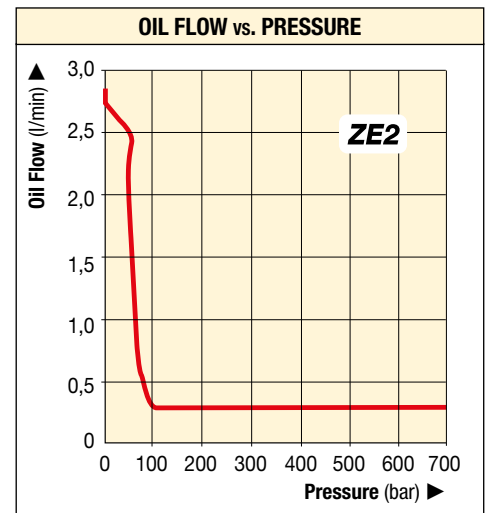

Used with Cylinder *	Valve Hold Function	Useable Oil Capacity (Litres)	Model Number ¹⁾ Two-Stage Pump	Oil Flow Rate at 50 Hz (l/min)		Valve Type	Valve Operation	Motor Voltage (VAC)	Motor Size (kW)	Sound Level (dBA)	Weight (kg)
				7 bar	700 bar						
S/A		6,8	ZE2108DE (B, I)	2,7	0,27	VE32D	Solenoid w/ Pendant	230	0,56	79	42,4
S/A		6,8	ZE2208ME (B, I) ²⁾	2,7	0,27	VM32	Manual w/o Pendant	230	0,56	79	37,8
S/A	●	6,8	ZE2308ME (B, I) ²⁾	2,7	0,27	VM33	Manual w/o Pendant	230	0,56	79	38,3
D/A	●	6,8	ZE2408ME (B, I) ²⁾	2,7	0,27	VM43	Manual w/o Pendant	230	0,56	79	38,3
S/A		6,8	ZE2208PE (B, I)	2,7	0,27	VM32	Manual w/ Pendant	230	0,56	79	41,3
S/A	●	6,8	ZE2308PE (B, I)	2,7	0,27	VM33	Manual w/ Pendant	230	0,56	79	41,7
D/A	●	6,8	ZE2408PE (B, I)	2,7	0,27	VM43	Manual w/ Pendant	230	0,56	79	41,7
S/A	●	6,8	ZE2308EE (B, I)	2,7	0,27	VE33	Solenoid w/ Pendant	230	0,56	79	49,0
D/A	●	6,8	ZE2408EE (B, I)	2,7	0,27	VE43	Solenoid w/ Pendant	230	0,56	79	49,0

* S/A = Single Acting, D/A = Double Acting

¹⁾ "B" suffix model numbers shown are 115 VAC, 1-phase, 50/60 Hz, CE compliant

"I" indicates pump is available in 208-240V, 1-phase, 50/60 Hz with NEMA 6/15 plug, CE compliant

"E" indicates pump is available in 208-240V, 1-phase, 50/60 Hz with European plug, CE compliant

¹⁾ All models can be ordered with the following Factory Installed Accessories/Options:

F = with Return Line Filter, **G** = with 0-1000 bar gauge (ø 63,5 mm), **S** = Single-stage pump unit

²⁾ Models can be ordered with Pressure Switch (P)

▼ EP3204JE-G, E-Pulse® Electric Hydraulic Pump



High productivity through innovative design



Interactive Pendant

Integrated pendant control with a magnet that fits securely into the handle of the pump.

- Operation, programming and diagnostics status provided to operator with yellow, green, and red LED as well as vibration pulses.
- Fault codes warn operators of any issues related to voltage, temperature, button controls, or if professional service is required.

Performance

- Two-stage pump with high flow/pressure ratio: 2,13 l/min at 175 bar; 0,52 l/min at 700 bar
- Smart controls enable motor to maintain constant power across the pressure range
- 24VDC power regulator minimizes effects of poor power supply
- Six-piston block design provides even flow for smooth operation of cylinder or tool.

Durability

- Durable aluminium housing
- High-efficiency permanent magnet, direct drive motor enables continuous use and long service life
- Built-in thermal protection
- IP Rating: IP54 on the pump, IP67 on the pendant.

Convenience

- Speed control with dial adjustment for precise operation *
- Pendant and cord management system
- Integrated pressure gauge with scalereading in bar, MPA and psi
- Convenient oil fill port, oil level indicator and automatic breather.



Variable Speed Control *

Speed control with dial adjustment for precise tool or cylinder operation. The adjustable speed range is approximately 25 to 100% of full rated output.



Tie Down Bracket

Enables pump mounting to a work surface: **MBEP1** optional Tie Down Bracket.



Manifold Mounting Bracket

Ability to mount AM21 and AM41 split-flow hydraulic manifolds: **MMBEP1** optional Manifold Mounting Bracket.

E-Pulse®, Electric Hydraulic Pumps



E-Pulse® Pumps

The Enerpac E-Pulse® pums drives high productivity through its innovative design.

Smart controls enable the motor to maintain constant power providing higher flow than traditional pumps.

Adjustable speed control enables precision as required *. E-Pulse® pumps are designed for convenience.

Features include a cord management system and integrated pendant control with a magnet that fits securely into the handle of the pump.

The durable aluminum housing is designed to give easy access for serviceability.

E-Pulse is the heart to any hydraulic system, ensuring high performance and providing ultimate convenience.

E Series



Reservoir Capacity:
3,0 litres

Flow at Rated Pressure:
0,52 l/min

Motor Size:
0,63 kW

Maximum Operating Pressure:
700 bar



3/2 Jog, 3/2 Dump, 4/3 Jog
pendant with 3 metres cord

LED status signal

Jog Operation

Latch Operation



3/2 Dump and Hold
pendant with 3 metres cord

LED status signal

Jog Operation

Dump System Pressure

▼ PERFORMANCE CHART

Pump Series/Type	Output Flow Rate (l/min)				Motor Voltage (VAC)	Plug Type	Current Draw (Amps)	Sound Level (dBA)
	1 bar	175 bar	350 bar	700 bar				
EP3....B-G					100-120	NEMA 5-15	12	70-85
EP3....I-G	3,61	2,13	0,95	0,52	200-250	NEMA 6-15	7	
EP3....E-G					200-250	Schuko CEE 7/7	7	

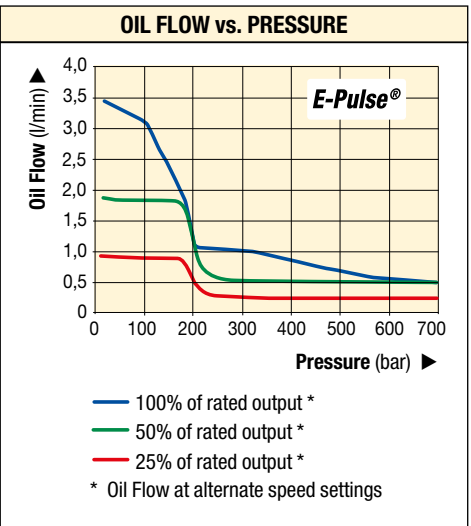

▼ SELECTION CHART

Used with cylinder or tool	Useable Oil Capacity (litres)	Model Number	Valve Type	Valve Function	Remote Pendant Functions	Weight (kg)
Single-Acting	3,0	EP3104DB-G	3/2 Solenoid	Dump	Advance	18,6
		EP3104DI-G				
		EP3104DE-G				
	3,0	EP3204JB-G *	3/2 Manual	Jog	Motor On/Off	18,4
		EP3204JI-G *				
		EP3204JE-G *				
3,0	EP3304SB-G *	3/2 Solenoid	Hold and Dump	Advance/Retract	18,7	
	EP3304SI-G *					
	EP3304SE-G *					
Double-Acting	3,0	EP3404JB-G *	4/3 Manual	Jog	Motor On/Off	18,6
		EP3404JI-G *				
		EP3404JE-G *				

* The adjustable speed control only applies to all EP3204, EP3304 and EP3404 pump models.

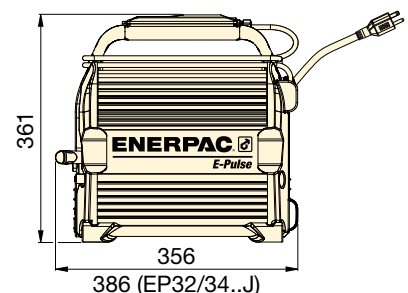
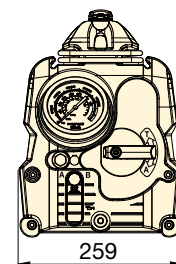

Introducing the Z-Class power pumps from Enerpac – pumps that run cooler, use less electricity and are easy to service.

Enerpac has used the latest metallurgical, bearing and seal technologies to produce a pump whose features and benefits far surpass the electric pumps that are available today. By reducing the number of moving parts, improving flow dynamics and decreasing friction, Z-Class pumps will stay on the job longer, require less energy to operate and when needed, have lower service costs.



Z-Class power pumps from Enerpac – simply the best pump you will ever use.

Z Tough
Dependable
Innovative
CLASS



Z-Class, An Innovation in Pump Design

Z-Class Pumping Element – The Heart of Your Hydraulic System

Highly efficient design provides increased flow rates, reduced heat generation and a decrease in power consumption. This means improved tool speed and increased service life – which results in higher productivity and lower operating costs.

Heavy-duty bearings extend pump life by reducing friction, reducing surface-loading and lowering bearing stresses.

Pump cavity oil bath extends pump life by reducing heat, improving lubrication and reducing wear.

Self-priming, high-flow 1st stage pump increases pump performance by super-charging the 2nd stage piston pump – improving oil flow in both hot and cold weather operation.

Balanced rotating components reduce vibration creating a smoother running pump – reducing wear, friction and sound levels.

Replaceable piston check-valves increase service life of major pump components.

Ergonomic pendant features sealed switches and operates at 24 V for improved operator safety.

Z-Class factory options & accessories

Extensive list of accessories including heat exchanger, roll cage, skid bar, pressure transducer, return line filter and level and temperature switches, allow complete pump control over a wide range of industrial applications.

Z-Class power pumps for your application

Available in one flow range for universal motor and eight flow ranges for induction motor. Choose from single or two-stage models to provide the optimum cylinder and tool performance for almost any industrial application.

Oil Flow Rate at 700 bar (l/min)	Z-Class Pump Series *	Electric Motor Power (kW)	Air Motor-Consumption (l/min)	Gasoline Engine Power (kW)	Page:
0,27	ZE2	0,56	–	–	92
0,52	ZC3	1,0	–	–	88
0,55	ZE3	0,75	–	–	104
0,82	ZE4(T)	1,12	–	–	104, 284
1,00	ZU4(T)	1,25	–	–	98, 280
1,30	ZA4(T)	–	2840	–	116, 288
1,60	ZG5	–	–	4,8	118
1,64	ZE5(T)	2,24	–	–	104, 284
2,73	ZE6	5,60	–	–	104
3,30	ZG6	–	–	9,7	118

* ZC3 battery powered cordless pumps
ZA4T, ZU4T, ZE4T and ZE5T-Series are Torque Wrench Pumps.

Back-lit LCD on select Z-Class pumps

- pump usage information, hour and cycle counts
- low-voltage warning and recording
- offers self-test and diagnostic capabilities
- information displayed in 6 languages
- pressure read-out (when used with the optional pressure transducer)
- adjustable trigger pressure setting (when used with the optional pressure transducer).



Back-lit LCD available in ZU and ZE-Series Electric Pumps. Pressure read-out in bar or psi. ►



ZU-Series Pump Applications

- **Mobile:** when frequent pump transport is required and/or on remote locations
- **Universal motor:** 1-phase, runs well under poor voltage supply, using generator power supply or using long extension cord
- **Duty-cycle:** for intermittent applications
- **Cylinders and tools:** for medium to large size single and double-acting applications and high speed
- **Pump speed:** two stage pump unit.



ZE-Series Pump Applications

- **Stationary:** when pump remains in one location
- **Induction motor:** 1 and 3-phase for high cycle usage
- **Duty-cycle:** for heavy-duty, extended cycle application
- **Cylinders and tools:** for medium to large size single and double-acting applications and high speed
- **Pump speed:** single or two stage pump unit.

▼ ZU4308ME (Classic), ZU4420SEH (Pro)



- High-efficiency two-speed pump design – higher oil flow and bypass pressure
- Powerful 1,25 kW universal electric motor provides high power-to-weight ratio and excellent low-voltage operating characteristics
- High-strength, moulded composite shroud protects motor and electronics, while providing an ergonomic, non-conductive handle for easy transport.

Pro-Series models only

- Back-lit LCD readout provides pressure display and a number of diagnostics and readout capabilities never offered on a portable pump before:
 - pump usage information, hour and cycle counts
 - self-test, diagnostic and read-out capabilities
 - pressure readout and auto-mode pressure settings.



◀ *Designed to be tough, the ZU4-Series with steel reservoirs will take the abuse of today's construction sites.*



Z-Class – A Pump For Every Application

Patented Z-Class pump technology provides high by-pass pressures for increased productivity – important in applications using long hose runs and high pressure-drop circuits, like heavy lifting or certain double-acting tools.

Enerpac ZU4-Series Pumps are built to power small to large-sized cylinders or hydraulic tools, or wherever high-speed, intermittent duty, remote hydraulic power is needed.

Classic Electric Pumps

- The Classic has traditional electro-mechanical components (transformers, relays and switches) in place of solid-state electronics.
- The Classic delivers durable, safe and efficient hydraulic power for demanding markets like construction, post-tensioning and foundation repair.

Standard Electric Pumps

- For applications that do not require digital display features of the Premium Pump. Available in all manual or jog versions.

Pro Electric Pumps

- Digital (LCD) display features a built-in hour meter and shows self-diagnostic, cycle-count and low voltage warning information.
- Pressure can also be displayed when the pump is equipped with an optional pressure transducer.



Assisted Return Pumps with Venturi Valve Technology

To improve productivity and plunger retraction, Enerpac offers valve configurations designed to accelerate your cylinder retraction speeds, ZU4-Series pumps feature **Venturi Valve Technology** to facilitate the faster return of single-acting gravity return cylinders. See valve type in ordering matrix and details in section Directional Control Valves.

ZU4-Series, Specifications and Dimensions

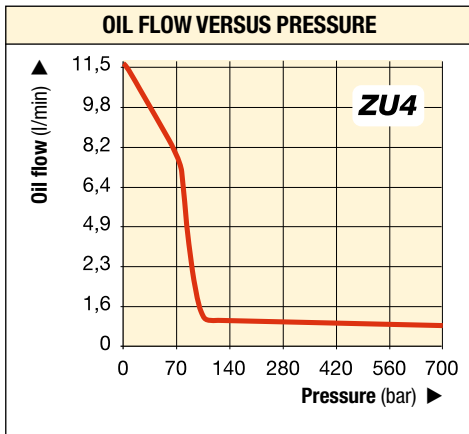

ZU4-SERIES PERFORMANCE CHART							
Motor Size (kW)	Output Flow Rate at 50 Hz (l/min)				Motor Electrical Specifications (Volts-Ph-Hz)	Sound Level (dBA)	Relief Valve Adjustment Range (bar)
	7 bar	50 bar	350 bar	700 bar			
1,25	11,5	8,8	1,2	1,0	115-1-50/60 230-1-50/60	85-90	140-700

ZU4 Series



Reservoir Capacity:
4,6 - 39 litres

Flow at Rated Pressure:
1,0 l/min

Motor Size:
1,25 kW

Maximum Operating Pressure:
700 bar

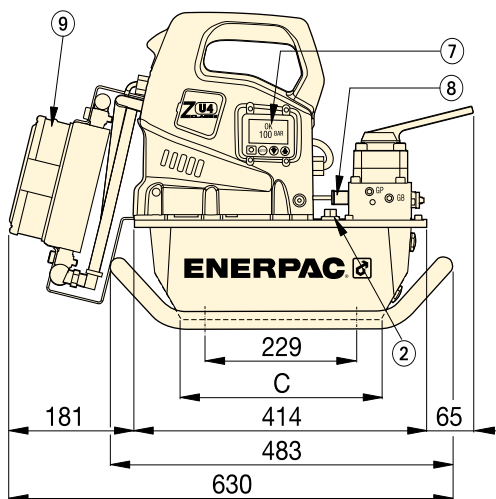

ZU4-Series with 4,6 and 6,8 litres reservoirs

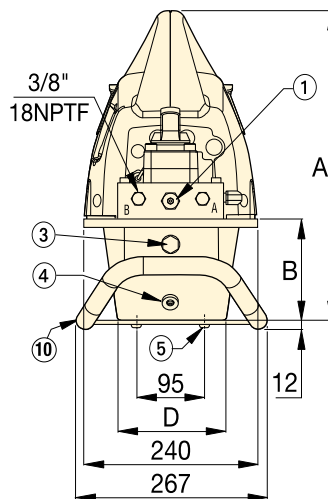

3/8"-18 NPTF Advance and Retract Ports

- ① User adjustable relief valve
- ② Oil fill port SAE #10 7/8"-14 UNF-2B
- ③ Oil level sight gauge
- ④ Oil drain 1/2" NPTF
- ⑤ M8, 6 mm deep
- ⑥ Handles on all 19,8 and 39 litres reservoirs.

Options

- ⑦ Back-lit LCD Electric
- ⑧ Pressure transducer
- ⑨ Heat Exchanger
- ⑩ Skid Bar. Fits 4,6 and 6,8 litres reservoirs
- ⑪ Handle guard installed on all 19,8 and 39 litres reservoirs
- ⑫ Reservoir handles (not shown) included on all 19,8 and 39 litres reservoirs

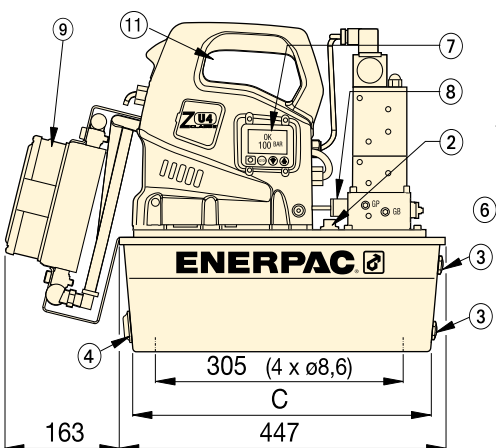

ZU4-Series with 19,8 and 39 litres reservoirs
(left view shown without side handle)

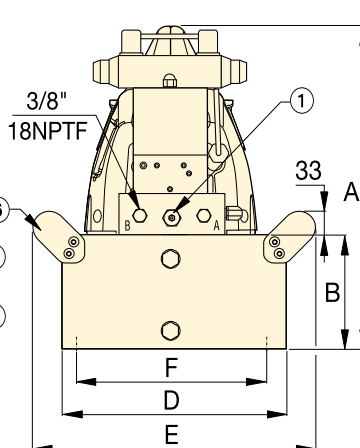

Pump Dimensions (mm)						
Reservoir Capacity (litres)	A	B	C	D	E	F
4,6	424	142	279	152	-	-
6,8	424	142	279	206	-	-
19,8	465	180	413	422	500	396
39	551	269	399	503	576	480

▼ STEP 1: Select a pump from the Pump Ordering Matrix

The functionality of the pump can be determined by the model number. Utilize the guide below to select the best pump for the application from the pump ordering matrix.

Z	U	4	4	08	J	E	-	H	R
1 Product Type	2 Motor Type	3 Flow Group	4 Valve Type	5 Reservoir Capacity	6 Valve Operation	7 Voltage		8 Factory Installed Accessories	

1 Product Type

Z = Pump Series

2 Motor Type

U = Universal electric motor

3 Flow Group

4 = 1,0 l/min @ 700 bar

4 Valve Type

- 1** = Dump (**VE32D**)
- 2** = 3 way/2 position manual or electric (**VM32** or **VE32**)
- 3** = 3 way/3 position manual or electric (**VM33** or **VE33**)
- 4** = 4 way/3 position manual or electric (**VM43** or **VE43**)
- 6** = 3 way/3 position locking manual with pilot operated check valve (**VM33L**)
- 7** = 3 way/2 position manual (**VM22**)
- 8** = 4 way/3 position locking manual with pilot operated check valve (**VM43L**)
- 9** = 4 way/3 position manual w/power seating (**VM43LPS**)
- 10** = 3 way/3 position manual Venturi valve (**VM33VAC**)
- 11** = 3 way/3 position electric Venturi valve (**VE33VAC**)

5 Reservoir Capacity

- 04** = 4,6 litres
- 08** = 6,8 litres
- 20** = 19,8 litres
- 40** = 39,0 litres

6 Valve Operation

- D** = Dump solenoid valve with pendant and LCD Electric
- J** = Jog manual valve with pendant (without LCD)
- L** = Manual valve with LCD Electric (without pendant)
- M** = Manual valve (without pendant and LCD)
- P** = Manual valve with pendant (without LCD)
- S** = Solenoid valve with pendant and LCD Electric

7 Voltage

- B** = 115V, 1 ph, 50/60Hz
- E** = 208-240V, 1 ph, 50/60 Hz (with European plug and CE EMC compliant)
- I** = 208-240V, 1 ph, 50/60 Hz (with NEMA 6-15 plug)

▼ STEP 2: Factory Installed Accessories

Select factory installed accessories and add to the pump model number after the hyphen. The example above shows that a **Heat Exchanger (H)** and **Roll Cage (R)** have been added to the pump.

8 Factory installed accessories include the following:

- | | |
|---|--|
| F = Return Line Filter | N = Lifting Eyes (no reservoir handles) |
| G = Pressure Gauge ¹⁾ | R = Roll Cage |
| H = Heat Exchanger | T = Pressure Transducer |
| K = Skid Bar | U = Foot Switch |
| L = Level/Temperature Switch ²⁾ | |

¹⁾ + ²⁾: See notes about Pressure Gauge and Level/Temperature Switch in right column.



Two Speed Pumps

Recommended for applications where cylinder plunger must advance rapidly to load contact, and applications where greater oil capacities are required, such as multiple cylinder hook-ups.



Speed Chart

To determine how a specific pump will operate your cylinder, see the Pump-Cylinder Speed Chart in the 'Yellow Pages'.

Page: 415



Assisted Return Pumps with Venturi Valve Technology

To improve productivity and plunger retraction, Enerpac offers valve configurations designed to accelerate your cylinder retraction speeds. ZU4 and ZE-Series pumps feature **Venturi Valve Technology** to facilitate the faster return of single-acting gravity and spring return cylinders. See valve type in ordering matrix and details in section Directional Control Valves.

Page: 122



Spring Centred Valve Kits

VM and VC-Series manual 3-position valves can be easily converted into spring centred valves. With these retro-fit kits the handle will automatically move into the neutral valve position when released.

Page: 123





Pressure Gauge, Level/Temperature Switch

¹⁾ Pressure Gauge (**G**) not available on pump models with pressure transducer (**T**). The pressure transducer provides digital pressure read-out on LCD-display.

²⁾ Level/Temperature Switch (**L**) requires electric package. Not available on reservoirs 04 and 08.

ZU4-Series, Pump Ordering Matrix

▼ ZU-PRO SERIES PUMP MODELS WITH SOLENOID VALVE, PENDANT AND LCD ELECTRIC

	S/A or D/A ¹⁾	Hold 	Valve Type ²⁾	Reservoir Capacity (litres)	 (kg)	Model Number 230 VAC, 1 phase, 50/60 Hz ³⁾
With Dump Valve <ul style="list-style-type: none"> Ideal for punching, crimping and cutting For use when load-holding is not required. 	S/A		VE32D	4,6	29	ZU4104DE (B, I)
	S/A		VE32D	6,8	31	ZU4108DE (B, I)
	S/A		VE32D	19,8	51	ZU4120DE (B, I)
	–		–	–	–	–
	–		–	–	–	–
With Solenoid Valves <ul style="list-style-type: none"> Ideal for lifting applications and where remote control is required Motor runs continuously on pumps with VE33 and VE43 valves. With VE32 valve, motor only runs during the advance function, while holding and retracting, the motor is off Venturi Valve technology (VE33VAC) for faster retract of single-acting cylinders. 	S/A	●	VE32	4,6	29	ZU4204SE (B, I)
	S/A	●	VE32	6,8	31	ZU4208SE (B, I)
	S/A	●	VE32	19,8	51	ZU4220SE (B, I)
	S/A	●	VE33	6,8	37	ZU4308SE (B, I)
	S/A	●	VE33	19,8	57	ZU4320SE (B, I)
	S/A	●	VE33	39,0	79	ZU4340SE (B, I)
	S/A	●	VE33VAC	6,8	34	ZU41108SE (B)
	S/A	●	VE33VAC	19,8	53	ZU41120SE (B)
	S/A	●	VE33VAC	39,0	76	ZU41140SE (B)
	D/A	●	VE43	6,8	37	ZU4408SE (B, I)
	D/A	●	VE43	19,8	56	ZU4420SE (B, I)
	D/A	●	VE43	39,0	79	ZU4440SE (B, I)

ZU4-Series



Reservoir Capacity:

4,6 - 39 litres

Flow at Rated Pressure:

1,0 l/min



Motor Size:

1,25 kW

Maximum Operating Pressure:

700 bar

▼ ZU-SERIES PUMP MODELS WITH MANUAL VALVES

	S/A or D/A ¹⁾	Hold 	Valve Type ²⁾	Reservoir Capacity (litres)	 (kg) ⁵⁾	Model Number 230 VAC, 1 phase, 50/60 Hz ³⁾		
						Manual Only	Standard Electric with Pendant	Classic Electric with Pendant ⁴⁾
With Manual Valves <ul style="list-style-type: none"> Ideal choice for most applications Manual valve control, for single-acting or double-acting applications Motor control on shroud Venturi Valve technology (VM33VAC) for faster retract of single acting cylinders Pendant models ideal for light production and lifting applications Locking valves provide hydraulic locking of cylinder until valve is shifted into retract position. 	S/A		VM22	4,6	27	ZU4704ME (B, I)	–	ZU4704PE (B, I)
	S/A		VM22	6,8	29	ZU4708ME (B, I)	–	ZU4708PE (B, I)
	S/A		VM22	19,8	49	ZU4720ME (B, I)	–	ZU4720PE (B, I)
	S/A		VM32	4,6	25	ZU4204ME (B, I)	ZU4204JE (B, I)	–
	S/A		VM32	6,8	28	ZU4208ME (B, I)	ZU4208JE (B, I)	–
	S/A		VM32	19,8	47	ZU4220ME (B, I)	ZU4220JE (B, I)	–
	S/A		VM32	39,0	70	ZU4240ME (B, I)	ZU4240JE (B, I)	–
	S/A	●	VM33	4,6	25	ZU4304ME (B, I)	–	–
	S/A	●	VM33	6,8	28	ZU4308ME (B, I)	ZU4308JE (B, I)	ZU4308PE (B)
	S/A	●	VM33	19,8	48	ZU4320ME (B, I)	ZU4320JE (B, I)	ZU4320PE (B)
	S/A	●	VM33	39,0	71	ZU4340ME (B, I)	ZU4340JE (B, I)	ZU4340PE (B)
	S/A	●	VM33VAC	6,8	29	ZU41008ME (B)	ZU41008JE (B)	–
	S/A	●	VM33VAC	19,8	48	ZU41020ME (B)	ZU41020JE (B)	–
	S/A	●	VM33L	6,8	30	ZU4608ME (B)	ZU4608JE (B)	–
	S/A	●	VM33L	19,8	49	ZU4620ME (B)	ZU4620JE (B)	–
	D/A	●	VM43	6,8	29	ZU4408ME (B, I)	ZU4408JE (B, I)	ZU4408PE (B)
	D/A	●	VM43	19,8	48	ZU4420ME (B, I)	ZU4420JE (B, I)	ZU4420PE (B)
	D/A	●	VM43	39,0	71	ZU4440ME (B, I)	ZU4440JE (B, I)	ZU4440PE (B)
	D/A	●	VM43L	4,6	30	ZU4808ME (B)	ZU4808JE (B)	–
	D/A	●	VM43L	19,8	50	ZU4820ME (B)	ZU4820JE (B)	–

¹⁾ S/A or D/A = For use with Single-Acting or Double-Acting cylinders and tools. ²⁾ Additional details can be found in the Directional Control Valve section

³⁾ "B" indicates pump is available in 115V, 1-phase, 50/60 Hz. Model number order example: **ZU4208MB**.

"I" indicates pump is available in 208-240V, 1-phase, 50/60 Hz with NEMA 6-15 plug. Model number order example: **ZU4208MI**.

⁴⁾ Classic Electric Pump has traditional electro-mechanical components (transformers, relays, switches) in place of solid-state electronics.

⁵⁾ Weights given for pump with manual valve. For Standard Electric with pendant add 0,5 kg and Classic Electric with pendant add 1,5 kg.

NOTE: Valve operation "L" available on pumps with manual valve. Substitute "M" for "L" valve operation. Example: **ZU4608LE**.



Roll Cage (R)

- Protects and stabilizes the pump.

Popular Pump Models with Factory Installed Roll Cage	
ZU4108DE-R (B, I)	ZU4308ME-R (B, I)
ZU4208JE-R (B, I)	ZU4320ME-R (B, I)
ZU4220JE-R (B, I)	ZU4408ME-R (B, I)
ZU4208SE-R (B, I)	ZU4420ME-R (B, I)
ZU4308JE-R (B, I)	ZU4408JE-R (B, I)
ZU4320JE-R (B, I)	ZU4420JE-R (B, I)
ZU4308SE-R (B, I)	ZU4408SE-R (B, I)
ZU4320SE-R (B, I)	ZU4420SE-R (B, I)

Accessory Kit Model Nr.	Fits on Reservoir
	
ZRC-04	4,6 and 6,8 litres ¹⁾
ZRC-04H	4,6 and 6,8 litres ²⁾
ZRB-20	19,8 litres
ZRB-40	39 litres

¹⁾ Without heat exchanger

²⁾ With heat exchanger



Foot Switch (U)

- 3 metres cord, hands-free control.

Popular Pump Models with Factory Installed Foot Switch	
ZU4108DE-U (B, I)	
ZU4208SE-U (B, I)	
ZU4220SE-U (B, I)	
ZU4320SE-U (B, I)	
ZU4408SE-U (B, I)	
ZU4420SE-U (B, I)	

Accessory Kit Model Nr.	Can be used on ZU4 Pumps with solenoid dump and 3-position valves, LCD electric
	
ZCF-2	Solenoid VE-Series valves

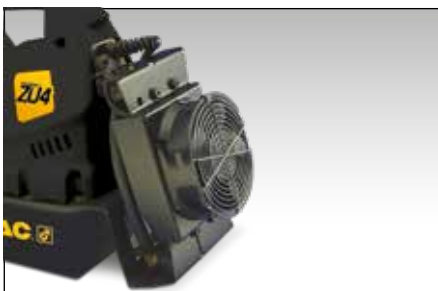

Heat Exchanger (H)

- Removes heat from bypass oil
- Increases oil life, reduces wear on hydraulic components.

Popular Pump Models with Factory Installed Heat Exchanger	
ZU4108DE-H (B, I)	
ZU4208SE-H (B, I)	
ZU4308SE-H (B, I)	
ZU4408SE-H (B, I)	
ZU4420SE-H (B, I)	

Accessory Kit Model Nr.	Can be used on
	
ZHE-U115	115 V pumps
ZHE-U230	230V pumps



Pressure Transducer (T)

- More durable than analog gauges
- Displays psi, bar or MPa
- Motor shutoff or shift to neutral at set pressure.

Popular Pump Models with Factory Installed Pressure Transducer, Requires LCD Electric Pump	
ZU4108DE-T (B, I)	
ZU4208SE-T (B, I)	
ZU4308SE-T (B, I)	
ZU4408SE-T (B, I)	
ZU4420SE-T (B, I)	

Accessory Kit Model Nr.	Adjustable Pressure Range	Switch-Point Repeatability	Dead-band
	(bar)	(%)	(bar)
ZPT-U4	3,5 - 700	± 0,5	3,5

Note: The pressure transducer provides digital pressure read-out on LCD-display.

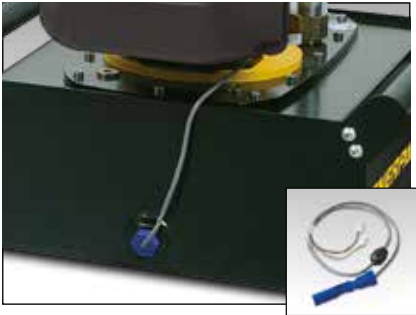

Level/Temperature Switch (L) ¹⁾

- Shuts off pump when high operating temperature or low oil is reached
- Plugs directly into pump electrical enclosure
- Easy installation to pump reservoir
- Requires LCD electric.



Return Line Filter (F)

- 25 micron filter removes contaminants from return oil flow
- Internal by-pass valve prevents damage if filter is dirty
- With maintenance indicator
- Replaceable filter element PF25.

ZU4 Series



Reservoir Capacity:

4,6 - 39 litres

Flow at Rated Pressure:

1,0 l/min

Motor Size:

1,25 kW

Maximum Operating Pressure:

700 bar

Accessory Kit Model Nr.	Operating Temperature (°C)	Maximum Pressure (bar)	Weight (kg)
ZLS-U4	5 - 110	10	0,1

¹⁾ Level/Temperature switch (L) not available on 4,6 or 6,8 litres reservoir.

Accessory Kit Model Nr.	Max. Pressure (bar)	Max. Oil Flow (l/min)	By-Pass Setting (bar)
ZPF	14	45	1,7



Heat Exchanger

Stabilizes oil temperature at a maximum of 54 °C at 21 °C ambient temperature.

Do not exceed maximum oil flow and pressure ratings. Heat exchanger is not suitable for water-glycol or water based fluids.

Thermal Transfer * (Btu/h)	Maximum Pressure (bar)	Maximum Oil Flow (l/min)	Voltage (VDC)
900	20,7	26,5	12

* At 1,9 l/min at 21 °C ambient temperature.



Skidbar (K)

- Provides easy two-hand lift
- Provides greater pump stability on soft or uneven surfaces
- Cannot be used in combination with roll cage.



Pressure Gauge (G)

- Minimize risk of overloading to ensure long life of equipment
- ø 63 mm face diameter, glycerin filled
- Dual scale in bar and psi.



Hoses

Enerpac offers a complete line of high-quality hydraulic hoses. To ensure the integrity of your system, specify only Enerpac hydraulic hoses.

Accessory Kit Model Nr.	Fits on Reservoir	Weight (kg)
SBZ-4	4,6 and 6,8 litres ²⁾	2,2
SBZ-4L	4,6 and 6,8 litres ³⁾	3,2

²⁾ Without heat exchanger

³⁾ With heat exchanger

Accessory Kit Model Nr.	Description
G2536L	0 - 1000 bar, 0 - 15.000 psi

Note: Pressure Gauge not available on pump models with pressure transducer. The pressure transducer provides digital pressure read-out on LCD-display.

▼ Shown from left to right: ZE3304ME-K, ZE4110DE-FHR



- High-efficiency pump design – higher oil flow and by-pass pressure
- High-strength, moulded electrical box protects electronics, power supplies and LCD readout and stands up to harsh industrial environments
- IP54 protection and isolation class
- Back-lit LCD provides self test, diagnostic and read-out capabilities never before offered on an industrial pump (included on pump with electric valves, optional on other models)
- Totally enclosed, fan-cooled industrial electric motors for extended life
- User adjustable relief valve built-in on manual and solenoid valves. Oil ports on valves are 3/8" NPTF
- Steel fan guard on all electric motors
- Full sight oil level glass on 9,8, 19,8 and 39 litres reservoirs, oil level indicators on 4,6 and 6,8 litres reservoirs.
- 40 micron filter breather with splash guard
- Durable steel reservoirs.



◀ Rail wheel pulling using RACH aluminium cylinder powered by ZE-Series pump.

ZE Series

Reservoir Capacity:

4,6 - 39 litres

Flow at Rated Pressure:

0,55 - 2,73 l/min

Motor Size:

0,75 - 5,60 kW

Maximum Operating Pressure:

700 bar

Z Tough
Dependable
Innovative
CLASS



Speed Chart

To determine how a specific pump will operate your cylinder, see the Pump-Cylinder Speed Chart in the 'Yellow Pages'.

Page: 415



Locking Valves

For applications requiring positive load holding, VM-Series valves (except VM32) are available with a pilot-operated check valve

VM33L and VM43L. This provides hydraulic locking of the load until the valve is shifted into the retract position.



Assisted Return Pumps

To improve productivity and plunger retraction, Enerpac offers valve configurations designed to accelerate your cylinder retraction

speeds, ZU4 and ZE-Series pumps feature **Venturi Valve Technology** to facilitate the faster return of single-acting gravity and spring return cylinders. See valve type in ordering matrix and details in section Directional Control Valves.

Page: 122

ZE-Series, Specifications & Dimensions

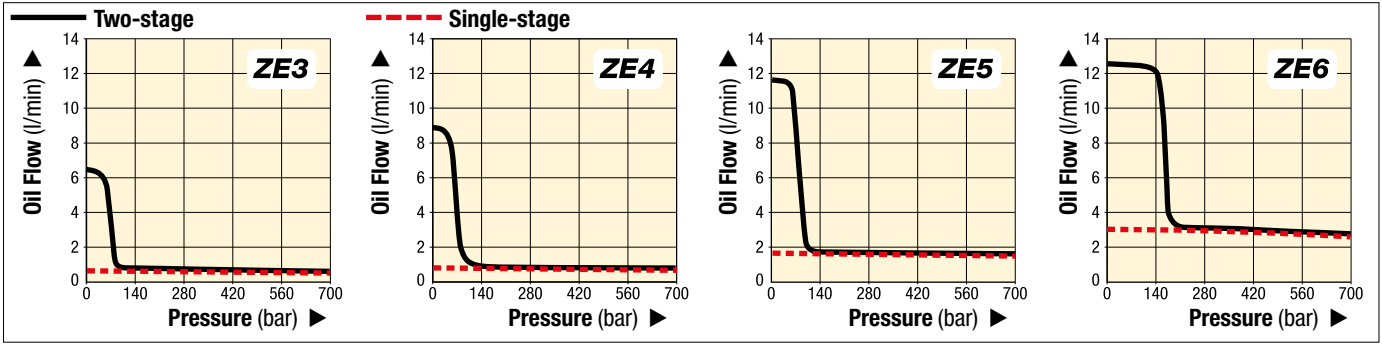

▼ ZE-SERIES PERFORMANCE CHART

Pump Series	Output Flow Rate at 50 Hz * (l/min)				Pump Unit	Available Reservoir Sizes (litres)	Motor Size (kW)	Relief Valve Adjustment Range (bar)	Sound Level (dBA)
	low pressure		high pressure						
	at 7 bar	at 50 bar	at 350 bar	at 700 bar					
ZE3	0,59	0,59	0,57	0,55	Single-stage	4,6 - 6,8 - 9,8	0,75	70-700	75
	6,15	5,26	0,57	0,55	Two-stage	19,8 - 39			
ZE4	0,87	0,87	0,84	0,82	Single-stage	4,6 - 6,8 - 9,8	1,12	70-700	75
	8,88	8,20	0,84	0,82	Two-stage	19,8 - 39			
ZE5	1,75	1,72	1,68	1,64	Single-stage	9,8 - 19,8 - 39	2,24	70-700	75
	11,61	11,27	1,68	1,64	Two-stage				
ZE6	3,00	2,94	2,86	2,73	Single-stage	9,8 - 19,8 - 39	5,60	70-700	80
	12,29	12,15	2,86	2,73	Two-stage				

* Oil flow will be approximately 6/5 of these values at 60 Hz.



Single or Two-Stage

Choose single-stage pumps for applications that require constant flow regardless of pressure such as testing or clamping. Two-stage pumps have an increased output flow at low pressure to allow fast movement towards the load, for reduced cycle times and increased productivity.

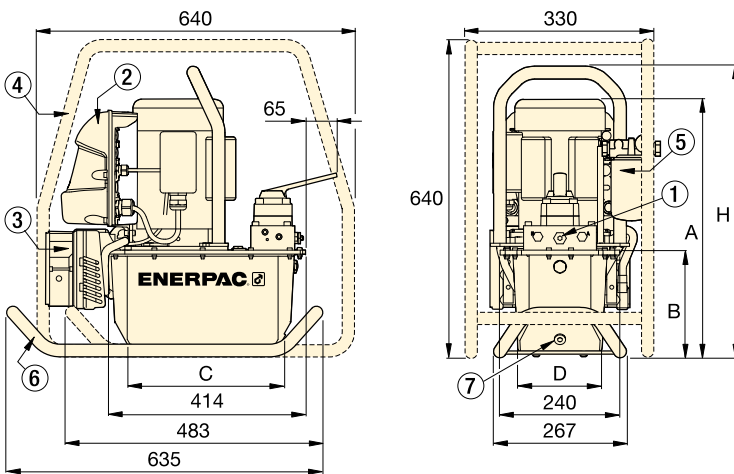

ZE-Series Pumps with 4,6 - 6,8 litres reservoir

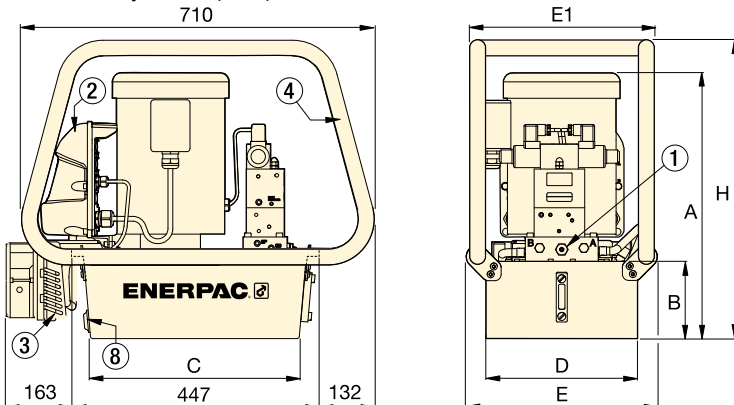

ZE-Series Pumps with 9,8 - 19,8 - 39 litres reservoir

- ① User adjustable relief valve on all manual and solenoid valves. $\frac{3}{8}$ " NPTF on A and B ports; $\frac{1}{4}$ " NPTF on auxiliary ports.
- ② Electric Box
- ③ Heat Exchanger
- ④ Roll Cage
- ⑤ Return Line Filter
- ⑥ Skid Bar
- ⑦ Magnetic Oil Drain
- ⑧ Oil Drain / Oil Level & Temperature Switch

Reservoir Size (litres)	ZE-Series Pump Dimensions (mm)						
	A	B	C	D	E	E1	H
4,6	457	143	279	152	-	-	513
6,8	457	143	279	206	-	-	513
9,8	533	158	419	305	384	371	600
19,8	558	180	419	422	501	488	625
39	648	270	399	505	576	572	715

▼ STEP 1: Select a pump from the Pump Ordering Matrix

The functionality of the pump can be determined by the model number. Utilize the guide below to select the best pump for the application from the pump ordering matrix..

Z	E	4	4	20	M	E	-	F	H
1	2	3	4	5	6	7		8	
Product Type	Motor Type	Flow Group	Valve Type	Reservoir Capacity	Valve Operation	Voltage		Factory Installed Accessories	

1 Product Type

Z = Pump Class

2 Prime Mover

E = Induction electric motor

3 Flow Group

3 = 0,55 l/min @ 700 bar

4 = 0,82 l/min @ 700 bar

5¹⁾ = 1,64 l/min @ 700 bar

6¹⁾ = 2,73 l/min @ 700 bar

4 Valve Type

0 = No valve, with cover plate

1 = 3/2 Dump valve **VE32D**

2 = 3/2 manual **VM32**

3 = 3/3 manual **VM33** or electric **VE33**

4 = 4/3 manual **VM43** or electric **VE43**

6 = 3/3 manual locking valve **VM33L** with pilot operated check

8 = 4/3 manual locking valve **VM43L** with pilot operated check

10⁶⁾ = 3 way/3 position manual **Venturi** valve **VM33VAC**

11⁶⁾ = 3 way/3 position electric **Venturi** valve **VE33VAC**

5 Reservoir Capacity

04 = 4,6 litres (not available on ZE5, ZE6)

08 = 6,8 litres (not available on ZE5, ZE6)

10 = 9,8 litres

20 = 19,8 litres

40 = 39,0 litres

6 Valve Operation

D = Dump solenoid valve with pendant and LCD

L = Manual valve with LCD Electric (without pendant)

M = Manual valve, without pendant or LCD

N = No valve, no electric box

S = Solenoid valve, with pendant and LCD

7 Motor Voltage

Single phase motor (not on ZE5, ZE6)

B¹⁾ = 115V, 1 ph, 50-60 Hz

E = 208-240V, 1 ph, 50-60 Hz with European SCHUKO Plug

I = 208-240V, 1 ph, 50-60 Hz with USA Nema 6-15 plug

Three phase motor³⁾

G = 208-240V, 3 ph, 50-60 Hz

J = 460-480V, 3 ph, 50-60 Hz

W = 380-415V, 3 ph, 50-60 Hz

▼ STEP 2: Factory Installed Accessories

Select factory installed accessories and add to the pump model number after the hyphen. The example above shows that a **Return Line Filter (F)** and **Heat Exchanger (H)** have been added to the pump.

8 Factory installed accessories include the following:

F = Return Line Filter

G = Pressure Gauge⁴⁾

H = Heat exchanger²⁾

K = Skid Bar

L = Level/Temperature switch²⁾

N = Lifting Eyes (no reservoir handles)⁷⁾

P = Pressure Switch²⁾

R = Roll Cage

S = Single stage pump unit⁵⁾

T = Pressure transducer²⁾⁴⁾

U = Foot switch²⁾

¹⁾ 115-volt pumps are supplied with 15-Amp plug for intermittent use. 20-Amp circuit recommended for frequent full pressure use.

²⁾ These accessories (H, L, P and T) require LCD electrical package. Level/Temperature switch (L) not available on 4,6 or 6,8 litres reservoir. Pressure switch option (P) only available on manual valves without locking valve. The LCD electrical package can accept either a pressure switch or pressure transducer, but not both.

³⁾ Pump with 3-ph motors without Electric Box shipped without cord, motor starter or overload protection.

⁴⁾ Pressure gauge (G) not available on pump models with pressure transducer. Pressure transducer provides digital pressure readout on LCD display.

⁵⁾ Not available on pumps with Venturi Valve Type 10 or 11.

⁶⁾ Not available on ZE3-Series pumps.

⁷⁾ Lifting eyes (N) not available on reservoir capacities 04 or 08.

▼ ZE-SERIES PUMP MODELS

No Valve, with coverplate, no electric box	
Manual Valve without electric box or LCD	<ul style="list-style-type: none"> • Ideal choice for most applications • Manual valve control, for both single-acting or double-acting applications • Venturi Valve Technology (VM33VAC) for faster retract of single-acting cylinders • Manual motor control • On/off switch on 1-phase electric motor.
Solenoid Dump Valve, electric box and LCD	<ul style="list-style-type: none"> • Ideal for punching, crimping and cutting • For use when load holding is not required • Push-button control pendant with 3 m. cord controls the valve and motor.
Solenoid 3-position Valve with Electric Box	<ul style="list-style-type: none"> • Ideal for production and lifting applications • All valves are 3-position for Advance-Hold-Retract • Venturi Valve Technology (VE33VAC) for faster retract of single-acting cylinders • Push-button control pendant with 3 m. cord controls the valve and motor.

ZE-Series, Pump Ordering Matrix

S/A or D/A ¹⁾	Hold 	Valve Type ²⁾	Reservoir Capacity (litres)	ZE3-Series (0,75 kW) Output Flow Rate at 700 bar: 0,55 l/min		ZE4-Series (1,12 kW) Output Flow Rate at 700 bar: 0,82 l/min		ZE5-Series (2,24 kW) Output Flow Rate at 700 bar: 1,64 l/min		ZE6-Series (5,60 kW) Output Flow Rate at 700 bar: 2,73 l/min	
				Model Number ³⁾ E = 230 V, 1 ph	(kg)	Model Number ³⁾ E = 230 V, 1 ph	(kg)	Model Number ³⁾ W = 400 V, 3 ph	(kg)	Model Number ³⁾ W = 400 V, 3 ph	(kg)
		–	6,8	ZE3008NE (B, I, J, G, W)	45	ZE4008NE (B, I, J, G, W)	43	–	–	–	–
		–	9,8	ZE3010NE (B, I, J, G, W)	45	ZE4010NE (B, I, J, G, W)	49	ZE5010NW (J, G)	54	ZE6010NW (J, G)	72
		–	19,8	ZE3020NE (B, I, J, G, W)	57	ZE4020NE (B, I, J, G, W)	61	ZE5020NW (J, G)	66	ZE6020NW (J, G)	84
		–	39,0	ZE3040NE (B, I, J, G, W)	80	ZE4040NE (B, I, J, G, W)	84	ZE5040NW (J, G)	89	ZE6040NW (J, G)	107
S/A	–	VM22	19,8	–	–	ZE4720ME (B, W)	65	–	–	–	–
S/A	–	VM32	4,6	ZE3204ME (B)	39	–	–	–	–	–	–
S/A	–	VM32	6,8	ZE3208ME (B, I, J, G, W)	41	ZE4208ME (B, I, J, G, W)	45	–	–	–	–
S/A	–	VM32	9,8	ZE3210ME (B, I, J, G, W)	47	ZE4210ME (B, I, J, G, W)	51	ZE5210MW (J, G)	56	ZE6210MW (J, G)	74
S/A	–	VM32	19,8	ZE3220ME (B, I, J, G, W)	59	ZE4220ME (B, I, J, G, W)	64	ZE5220MW (J, G)	68	ZE6220MW (J, G)	86
S/A	●	VM33	4,6	ZE3304ME (B)	39	–	–	–	–	–	–
S/A	●	VM33	6,8	ZE3308ME (B, I, J, G, W)	42	ZE4308ME (B, I, J, G, W)	46	–	–	–	–
S/A	●	VM33	9,8	ZE3310ME (B, I, J, G, W)	48	ZE4310ME (B, I, J, G, W)	52	ZE5310MW (J, G)	57	ZE6310MW (J, G)	75
S/A	●	VM33	19,8	ZE3320ME (B, I, J, G, W)	60	ZE4320ME (B, I, J, G, W)	64	ZE5320MW (J, G)	69	ZE6320MW (J, G)	87
S/A	●	VM33	39,0	ZE3340ME (B, I, J, G, W)	83	ZE4340ME (B, I, J, G, W)	87	ZE5340MW (J, G)	92	ZE6340MW (J, G)	110
S/A	●	VM33VAC	6,8	–	–	ZE41008ME (B, I, J, G, W)	46	–	–	–	–
S/A	●	VM33VAC	19,8	–	–	ZE41020ME (B, I, J, G, W)	64	ZE51020MW (J, G)	69	ZE61020MW (J, G)	87
S/A	●	VM33VAC	39,0	–	–	–	–	ZE51040MW (J, G)	92	ZE61040MW (J, G)	110
S/A	●	VM33L	6,8	ZE3608ME (B, I, J, G, W)	42	–	–	–	–	–	–
S/A	●	VM33L	19,8	ZE3620ME (B, I, J, G, W)	62	ZE4620ME (B, I, J, G, W)	66	–	–	–	–
S/A	●	VM33L	39,0	ZE3640ME (B, I, J, G, W)	85	ZE4640ME (B, I, J, G, W)	89	–	–	–	–
D/A	●	VM43	4,6	ZE3404ME (B)	39	–	–	–	–	–	–
D/A	●	VM43	6,8	ZE3408ME (B, I, J, G, W)	42	ZE4408ME (B, I, J, G, W)	46	–	–	–	–
D/A	●	VM43	9,8	ZE3410ME (B, I, J, G, W)	48	ZE4410ME (B, I, J, G, W)	52	ZE5410MW (J, G)	57	ZE6410MW (J, G)	74
D/A	●	VM43	19,8	ZE3420ME (B, I, J, G, W)	60	ZE4420ME (B, I, J, G, W)	64	ZE5420MW (J, G)	69	ZE6420MW (J, G)	87
D/A	●	VM43	39,0	ZE3440ME (B, I, J, G, W)	83	ZE4440ME (B, I, J, G, W)	87	ZE5440MW (J, G)	92	ZE6440MW (J, G)	110
D/A	●	VM43L	6,8	ZE3808ME (B, I, J, G, W)	44	–	–	–	–	–	–
D/A	●	VM43L	19,8	ZE3820ME (B, I, J, G, W)	62	ZE4820ME (B, I, J, G, W)	66	ZE5820MW (J, G)	71	ZE6820MW (J, G)	–
D/A	●	VM43L	39,0	ZE3840ME (B, I, J, G, W)	85	ZE4840ME (B, I, J, G, W)	89	ZE5840MW (J, G)	94	ZE6840MW (J, G)	112
S/A	–	VE32D	4,6	ZE3104DE (B, I, J, G, W)	43	–	–	–	–	–	–
S/A	–	VE32D	6,8	ZE3108DE (B, I, J, G, W)	45	ZE4108DE (B, I, J, G, W)	49	–	–	–	–
S/A	–	VE32D	9,8	ZE3110DE (B, I, J, G, W)	52	ZE4110DE (B, I, J, G, W)	55	ZE5110DW (J, G)	62	ZE6110DW (J, G)	79
S/A	–	VE32D	19,8	ZE3120DE (B, I, J, G, W)	64	ZE4120DE (B, I, J, G, W)	68	ZE5120DW (J, G)	74	ZE6120DW (J, G)	92
S/A	–	VE32D	39,0	–	–	ZE4140DE (B, I, J, G, W)	91	ZE5140DW (J, G)	97	ZE6140DW (J, G)	114
S/A	●	VE33	4,6	ZE3304SE (B, I, J, G, W)	48	–	–	–	–	–	–
S/A	●	VE33	6,8	ZE3308SE (B, I, J, G, W)	51	ZE4308SE (B, I, J, G, W)	55	–	–	–	–
S/A	●	VE33	9,8	ZE3310SE (B, I, J, G, W)	57	ZE4310SE (B, I, J, G, W)	61	ZE5310SW (J, G)	67	ZE6310SW (J, G)	84
S/A	●	VE33	19,8	ZE3320SE (B, I, J, G, W)	69	ZE4320SE (B, I, J, G, W)	73	ZE5320SW (J, G)	79	ZE6320SW (J, G)	97
S/A	●	VE33	39,0	ZE3340SE (B, I, J, G, W)	92	ZE4340SE (B, I, J, G, W)	96	ZE5340SW (J, G)	102	ZE6340SW (J, G)	120
S/A	●	VE33VAC	6,8	–	–	ZE41108SE (B, I, J, G, W)	52	–	–	–	–
S/A	●	VE33VAC	19,8	–	–	ZE41120SE (B, I, J, G, W)	70	ZE51120SW (J, G)	76	ZE61120SW (J, G)	94
S/A	●	VE33VAC	39,0	–	–	–	–	ZE51140SW (J, G)	99	ZE61140SW (J, G)	117
D/A	●	VE43	4,6	ZE3404SE (B, I, J, G, W)	48	–	–	–	–	–	–
D/A	●	VE43	6,8	ZE3408SE (B, I, J, G, W)	51	ZE4408SE (B, I, J, G, W)	55	–	–	–	–
D/A	●	VE43	9,8	ZE3410SE (B, I, J, G, W)	57	ZE4410SE (B, I, J, G, W)	61	ZE5410SW (J, G)	67	ZE6410SW (J, G)	84
D/A	●	VE43	19,8	ZE3420SE (B, I, J, G, W)	69	ZE4420SE (B, I, J, G, W)	73	ZE5420SW (J, G)	79	ZE6420SW (J, G)	97
D/A	●	VE43	39,0	ZE3440SE (B, I, J, G, W)	92	ZE4440SE (B, I, J, G, W)	96	ZE5440SW (J, G)	102	ZE6440SW (J, G)	120

¹⁾ S/A or D/A = For use with Single-Acting or Double-Acting cylinders and tools. ²⁾ Additional details can be found in the Directional Control Valve section.

³⁾ "E" suffix model numbers shown are 230 VAC, 1-phase, 50/60 Hz. "W" suffix model numbers shown are 400 VAC, 3-phase, 50/60 Hz. Other voltages available as shown.

Replace "E" voltage suffix with selected voltage character. Model number order example: **ZE4108DB** is 115VAC, 1 phase, 50/60 Hz. See Ordering Guide page 106 for voltage descriptions.

NOTE: Voltage options K (440 VAC, 3-phase, 50/60 Hz) and R (575 VAC, 3-phase, 60 Hz) are available on select models. Contact your local representative for availability.

NOTE: Valve operation "L" available on pumps with manual valve. Substitute "M" for "L" valve operation. Example: **ZE3608LE**.



Electric Box ¹⁾

- Back-lit LCD
- Pump usage information, hour and cycle counts
- Low-voltage warning and recording
- Self-test and diagnostic capabilities
- Pressure read-out ²⁾
- Auto-mode pressure setting ²⁾
- Information can be displayed in six languages ³⁾

¹⁾ Included on pumps with solenoid valves.

²⁾ When used with optional pressure transducer.

³⁾ English, French, German, Italian, Spanish and Portuguese.

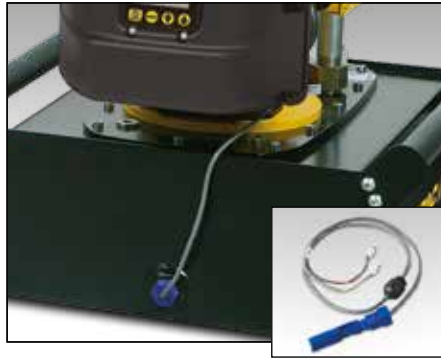

Level & Temperature Switch (L) ⁴⁾

- Shuts down pump before oil level reaches an unsafe level, avoiding damage due to cavitation
- Shuts down pump when unsafe oil temperature is reached
- Ideal if pump is used in remote area without visual access to oil level.

⁴⁾ 24 V, requires Electric Box. Available for 9,8; 19,8 and 39 litres reservoirs.



Return Line Filter (F)

- 25 micron nominal filter removes contaminants from return oil flow before allowing it back into tank
- Internal by-pass valve prevents damage if filter is dirty
- With maintenance indicator
- Replaceable filter element PF25.

Accessory Kit Modelnr.	Fixed Temperature Signal (°C)	Operating Temperature (°C)	Max. Pressure (bar)
ZLS-U4	80	5 - 110	10

Accessory Kit Modelnr.	Maximum Pressure (bar)	Maximum Oil Flow (l/min)	By-pass Setting (bar)
ZPF	13,8	45,4	1,7



Roll Cage (R)

- For easy portability and hoisting
- Protects pump and electric box
- Available for all reservoir sizes.



Skid Bar (K)

- Provides easy two-hand lift
- Provides greater pump stability on soft or uneven surfaces.



Foot Switch (U) ⁷⁾

- Hands-free remote control on solenoid dump and 3-position valves
- With 3 meters cord.

⁷⁾ 15 V, requires Electric Box.

Accessory Kit Nr.	Fits on reservoir size:	(kg)
ZRC-04	4,6 and 6,8 litres ⁵⁾	5,5
ZRC-04H	4,6 and 6,8 litres ⁶⁾	6,5
ZRB-10	9,8 litres	6,0
ZRB-20	19,8 litres	6,0
ZRB-40	39 litres	6,0

⁵⁾ For pump without heat exchanger

⁶⁾ For pump with heat exchanger.

Accessory Kit Nr.	Fits on reservoir size:	(kg)
SBZ-4	4,6 and 6,8 litres ⁵⁾	2,2
SBZ-4L	4,6 and 6,8 litres ⁶⁾	3,2

⁵⁾ For pump without heat exchanger

⁶⁾ For pump with heat exchanger.

Accessory Kit Nr.	Can be used on ZE-Series pumps with
ZCF-2	Solenoid VE-Series valves



Pressure Transducer (T) ¹⁾

- Displays pressure on LCD in bar, MPa or psi
- More accurate than analog gauge
- Calibration can be fine-tuned for certification
- Easy-viewing variable rate display
- "Set pressure" feature turns off motor at user defined pressure.

¹⁾ 24 V, requires Electric Box.



Pressure Switch (P) ²⁾

- Controls pump, monitors system
- Adjustable pressure 35-700 bar
- Includes glycerine filled 1000 bar pressure gauge G2536L
- Accuracy $\pm 1,5\%$ of full scale.

²⁾ 24 V, requires Electric Box. Not available in combination with pressure transducer. Not available on LCD-electronics.

Accessory Kit Modelnr.	Adjustable Pressure Range (bar)	Switch-point repeatability	Dead-band (bar)
ZPT-U4	3,5 - 700	$\pm 0,5\%$	3,5

Accessory Kit Modelnr.	Switch-point repeatability	Deadband (bar)	Oil Ports (NPTF)
ZPS-E3	$\pm 2\%$	8 - 38	3/8"



Heat Exchanger (H) ³⁾

- Removes heat from by-pass oil to provide cooler operation
- Stabilizes oil viscosity, increasing oil life and reduces wear of pump and other hydraulic components.

³⁾ 24 VDC, requires electric box.



Pressure Gauge (G)

- Minimize risk of overloading to ensure long life of equipment
- $\varnothing 63$ mm face diameter, glycerin filled
- Dual scale in bar and psi.

Note: Pressure Gauge not available on pump models with pressure transducer. The pressure transducer provides digital pressure read-out on LCD-display.

Accessory Kit Nr.	Fits on reservoir size:	(kg)
ZHE-E04	4,6 and 6,8 litres	4,1
ZHE-E10	9,8; 19,8 and 39 litres	4,1

Accessory Kit Model Nr.	Description
G2536L	0 - 1000 bar, 0 - 15.000 psi

ZE Series



Reservoir Capacity:

4,6 - 39 litres

Flow at Rated Pressure:

0,55 - 2,73 l/min

Motor Size:

0,75 - 5,60 kW

Maximum Operating Pressure:

700 bar



ZPT-U4 Pressure Transducer

More durable against mechanical and hydraulic shock than analog gauges.

- Digital pressure read-out provides accuracy of 0,5% of full scale.
- Easy-viewing variable rate display automatically varies increments between 3, 14, 35 and 145 bar as rate of pressure change increases.
- "Set pressure" feature turns off motor at user defined pressure (or shifts valve to neutral on VE33 and VE43 valves).



ZHE-Series Heat Exchangers

Heat exchanger stabilizes oil temperature at 54 °C at 21 °C ambient temperature. Thermal transfer at

1,9 l/min and 21 °C ambient temperature: 900 Btu/hour [950 kJ].

Do not exceed max. oil flow of 26,5 l/min and max. pressure of 20,7 bar. Not suitable for water-glycol or high water based fluids.

PA-Series, Air Hydraulic Foot Pumps

ENERPAC 

▼ Shown: PA1150, PA133



PA Series

Reservoir Capacity:
0,6 - 1,3 litres

Flow at Rated Pressure:
0,13 l/min

Air Consumption:
255 l/min

Maximum Operating Pressure:
700 bar



Reservoir Conversion Kit

Double the reservoir capacity of your existing PA133 with this easy to install conversion kit.

Model Number

PC66

- Rugged construction – built for long life and easy service
- Swivel coupling simplifies hydraulic connection and pump operation
- Three-position treadle provides cylinder advance, hold or retract operation
- Operates in all positions for increased versatility in use and mounting (except PA1150)
- Base mounting slots provided on PA133.

OIL FLOW VERSUS PRESSURE

at 6,9 bar air pressure

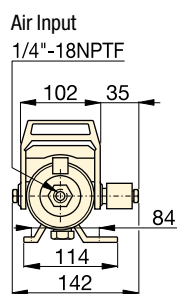
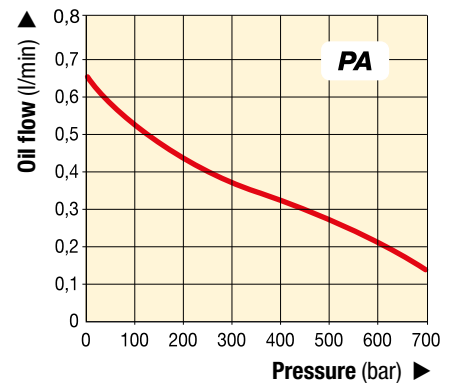

PA133

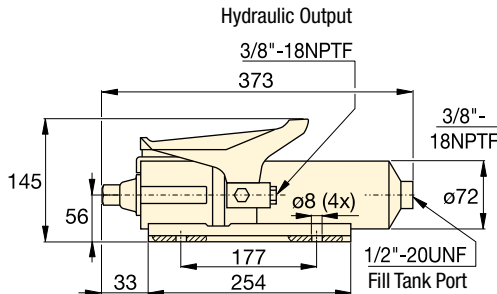

PA1150

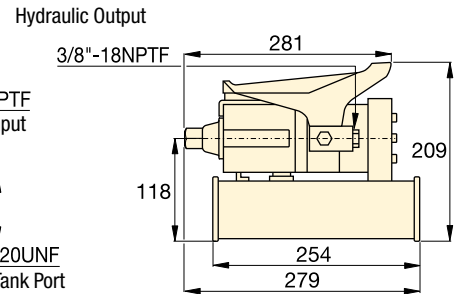
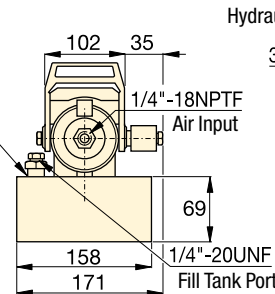

Used with Cylinder	Usable Oil Capacity (cm ³)	Model Number	Pressure Rating (bar)	Output Flow Rate (l/min)		Valve Function	Air Pressure Range * (bar)	Air Consumption (l/min)	Sound Level (dBA)	 (kg)
				No load	Load					
Single-Acting	589	PA133	700	0,65	0,13	Advance / Hold / Retract	4,1 - 8,3	255	85	5,4
	1311	PA1150	700	0,65	0,13	Advance / Hold / Retract	4,1 - 8,3	255	85	8,2

* Recommended Regulator-Filter-Lubricator: RFL102.

PAM-Series, Air Hydraulic Pumps

▼ Shown: PAM1041



PAM Series

Reservoir Capacity:

4,0 - 8,0 litres

Flow at Rated Pressure:

0,15 l/min

Air Consumption:

510 l/min

Maximum Operating Pressure:

700 bar



Locking Valves

Pumps with 4/3 manual valves are available with 4/3 manual locking valves **VM4L** instead. Add suffix "L" to pump model number. Example: **PAM1042L**.

Page: **122**

- Twin air motor configuration delivers high-flow performance in first stage, up to 14 bar, for rapid cylinder advance
- 4 and 8 litres reservoirs for use with a wide range of cylinders
- Integral shroud protects air motors and provides easy portability.



Remote Air Valve

For remote operation of PAM-Series air pumps. Permits either hand or foot operation.

Model Number

VA2

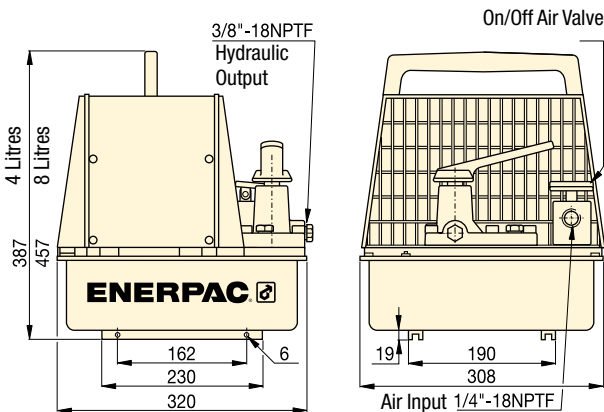

OIL FLOW VERSUS PRESSURE

at 6,9 bar air pressure

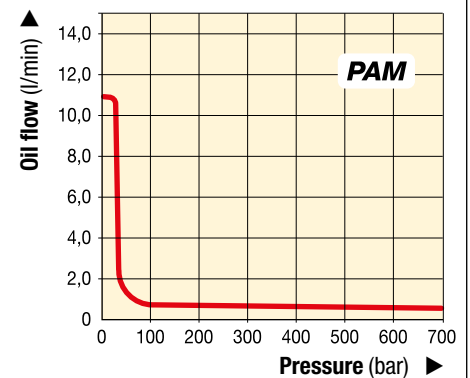

Used with Cylinder	Usable Oil Cap. (litres)	Model Number with Shroud	Pressure Rating (bar)	Output Flow Rate (l/min)		Valve Function	Valve Type	Valve Model Number	Air Pressure Range * (bar)	Air Consumption (l/min)	Sound Level (dBA)	Weight (kg)
				1 st stage	2 nd stage							
Single-Acting	2,6	PAM1021	700	10,65	0,15	Advance/Hold/Retract	3/2	VM2	4,1 - 8,3	510	87	22,7
	7,6	PAM1022	700	10,65	0,15	Advance/Hold/Retract	3/2	VM2	4,1 - 8,3	510	87	27,2
Double-Acting	2,6	PAM1041	700	10,65	0,15	Advance/Hold /Retract	4/3	VM4	4,1 - 8,3	510	87	22,7
	7,6	PAM1042	700	10,65	0,15	Advance/Hold/Retract	4/3	VM4	4,1 - 8,3	510	87	27,2

* Recommended Regulator-Filter-Lubricator: **RFL102**.

▼ Shown from top to bottom: PAMG1402N, PARG1102N, PATG1102N, PATG1105N



- External adjustable pressure relief valve (behind sight glass)
- Return-to-tank port for use in remote valve applications
- Internal pressure relief valve provides overload protection
- Quieter operation – reduced noise level to 76 dBA
- Operating air pressure: 2,8 - 8,8 bar, enables pump to start at extremely low pressure
- High efficiency cast aluminium air motor
- Reinforced heavy-duty lightweight reservoir for applications in tough environments
- Air pendant for remote control operation.

Compact Air Over Hydraulic



Regulator-Filter-Lubricator

Recommended for use with all Turbo air pumps. Provides clean, lubricated air and allows for air pressure adjustment. Steel bowl guards are standard.

Model Number

RFL102



Large Reservoir Models

The Turbo II Air Pump is also available with an enlarged reservoir: **PATG1105N**, **PAMG1405N** and **PARG1105N**.



Hoses

Enerpac offers a complete line of high quality hydraulic hoses. To ensure the integrity of your system, specify only genuine Enerpac hydraulic hoses.

Page: **128**

▼ Easily operated by hand or by foot.



Used with Cylinder	Usable Oil Capacity (cm ³)	Model Number
Single-Acting	2081	PATG1102N
	3770	PATG1105N
Single-Acting	2081	PARG1102N
	3770	PARG1105N
Double-Acting	2081	PAMG1402N
	3770	PAMG1405N

PA-Series, Turbo II Air Hydraulic Pumps



PATG-models use a foot or hand operated treadle to control air and valve functions.

PAMG-models use a treadle with a locking feature to control air, and a 4-way manual valve to control hydraulics.

PARG-models use air pendant for remote control.

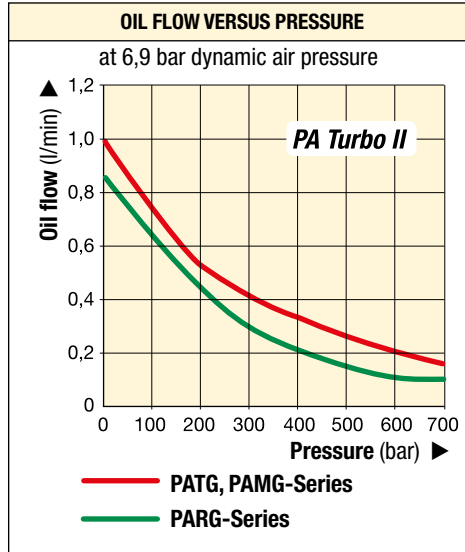

PATG PAMG PARG Series



Reservoir Capacity:

2,5 - 5,0 litres

Flow at Rated Pressure:

0,10 - 0,16 l/min

Air Consumption:

227 - 340 l/min

Maximum Operating Pressure:

700 bar

Maximum Pressure (bar)	Output Flow Rate (l/min)		Pump Series	Valve Function	Air Pressure Range (bar)	Air Consumption at 5,2 bar air (l/min)	Sound Level (dBA)
	No Load	Load					
700	1,00	0,16	PATG	A / H / R *	2,8 - 8,8	340	76
700	0,76	0,10	PARG	A / H / R *	2,8 - 10,3	227	76
700	1,00	0,16	PAMG	A / H / R *	2,8 - 8,8	340	76

* Valve function: Advance / Hold / Retract.



Speed Chart

To determine how a specific pump will operate your cylinder, see the Pump-Cylinder Speed Chart in the 'Yellow Pages'.

Page: 415

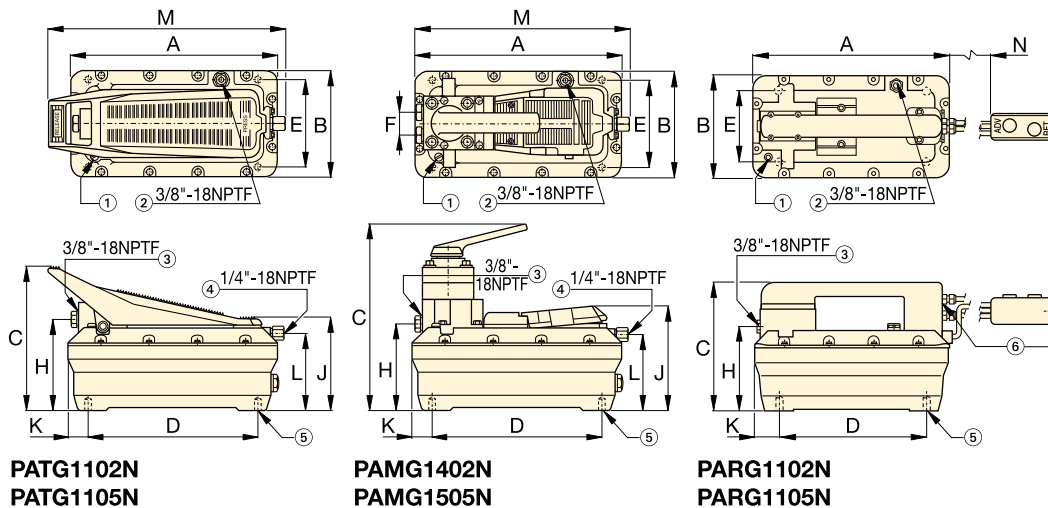

- ① Filtered 'Permanent' Tank Vent
- ② Return-to-Tank/Auxiliary Vent/Fill Tank Port
- ③ Hydraulic Output
- ④ Swivel Air Input with Filter
- ⑤ 4 Mounting Holes for #10 thread forming screw. Max. depth into reservoir = 19 mm
- ⑥ Air Input with Filter on PARG models 1/4"-18NPTF

**PATG1102N
PATG1105N**

**PAMG1402N
PAMG1505N**

**PARG1102N
PARG1105N**

Valve Operation	Turbo II Dimensions (mm)													Model Number
	A	B	C	D	E	F	H	J	K	L	M	N	(kg)	
Treadle 3/3	313	165	211	230	102	-	129	146	42	113	347	-	8,2	PATG1102N
	396	201	209	230	102	-	131	146	86	112	437	-	9,9	PATG1105N
Air Pendant 3/3	313	165	200	230	102	-	129	-	42	-	-	4500	10,0	PARG1102N
	396	201	209	230	102	-	131	-	86	-	-	4500	11,7	PARG1105N
Manual 4/3	313	165	267	230	102	36	130	152	42	113	315	-	11,0	PAMG1402N
	396	201	267	230	102	36	132	152	86	112	405	-	12,7	PAMG1405N

▼ Shown: **XA11G**



- Ergonomic design for less operator fatigue
- Variable oil flow & fine metering for precise control
- Higher oil flow for increased productivity
- Closed hydraulic system prevents contamination and allows pump usage in any position
- Pedal lock function for retract position
- External adjustable pressure setting valve
- Ground screw for improved ATEX explosion safety.

II 2 GD ck T4

▼ *Easy operated by foot. No need to fully lift up foot – rest bodyweight on heel, resulting in a handsfree and stabile working position.*



Productivity & Ergonomics



Optional Pressure Gauge

Integrated gauge with calibrated scale reading in bar, psi and MPa for actual pressure reading.



4/3 Control Valve

For powering double-acting hydraulic cylinders and tools.



2 Litres Reservoir

Double oil capacity for powering larger hydraulic cylinders and tools.



"Joy-stick" Lever Kit

Customer installed set of handles for manual operation of both pedals.

Model Number¹⁾

XLK1



Swivel Connector

Customer installed swivel connector for optimal orientation of the hydraulic hose. See page 133 for details.

Model Number¹⁾

XSC1

¹⁾ Accessories must be ordered separately.

Air Driven Hydraulic Foot Pumps



Production Application

XA11 pump is used with a 13 tons hollow cylinder to compress and position diesel engine valve springs.

The operator benefits from the fine metering capacities of this pump to apply the mandatory precise stroke and force.

XA Series



Reservoir Capacity:

1,0 - 2,0 litres

Flow at Rated Pressure:

0,25 l/min

Air Consumption:

283 - 991 l/min

Maximum Operating Pressure:

700 bar

▼ XA-SERIES PERFORMANCE CHART

Maximum Pressure (bar)	Output Flow Rate (l/min)		Pump Series	Valve Function	Dynamic Air Pressure (bar)
	No load	Load			
700	2,0	0,25	XA1	Advance / Hold / Retract	2,1 - 8,6

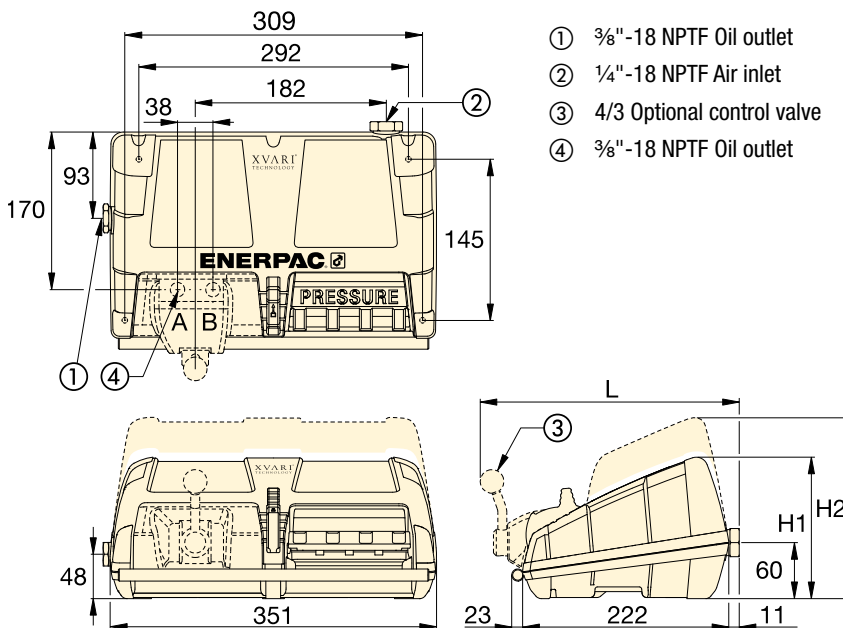

OIL FLOW VERSUS PRESSURE

at 6,9 bar dynamic air pressure

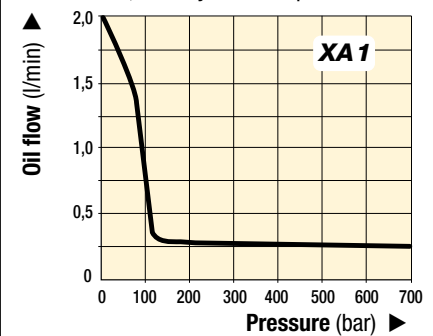

Regulator-Filter-Lubricator

Recommended for use with all XA-Series Air pumps. Provides clean, lubricated air and allows for air pressure adjustment.

Model Number¹⁾

RFL102

▼ SELECTION CHART

For use with cylinder or tool	Usable Oil Capacity (litres)	Model Number ¹⁾	Pressure Gauge	3-way 3-pos. Valve	4-way 3-pos. Valve	Dimensions (mm)			Weight (kg)
						H1	H2	L	
Single-acting	1,0	XA11 ²⁾	–	•	–	152	–	–	8,6
	2,0	XA12 ²⁾	–	•	–	–	170	–	10,2
Single-acting	1,0	XA11G	•	•	–	152	–	–	8,8
	2,0	XA12G	•	•	–	–	170	–	10,4
Double-acting	1,0	XA11V	–	–	•	152	–	279	10,1
	2,0	XA12V	–	–	•	–	170	279	11,7
Double-acting	1,0	XA11VG	•	–	•	152	–	279	10,3
	2,0	XA12VG	•	–	•	–	170	279	11,9

¹⁾ High-Flow coupler CR400 and accessories must be ordered separately. ²⁾ Available as cylinder-pump set, see page 62.

▼ Shown: ZA4208MX, ZA4420MX



Z Tough Dependable Innovative CLASS



ATEX 95 Certified

The Enerpac ZA4-series air pumps are tested and certified according to the **Equipment Directive 94 / 9 / EC** "ATEX Directive" for equipment and protective systems intended for use in potentially explosive atmospheres.



II 2 GD ck T4
DEKRA 0602

Page: 405

- ATEX 95 certified for use in potentially explosive atmospheres
- Features Z-Class high efficiency pump design, higher oil flow and bypass pressure
- Two-speed operation reduces cycle time for improved productivity
- User adjustable relief valve built-in on manual valves. Oil ports on valves are 3/8" NPTF
- Optional heat exchanger warms exhaust air to prevent freezing and cools the oil
- Full sight oil level glass on 9,8, 19,8 and 39 litres reservoirs, oil level indicators on 4,6 and 6,8 litres reservoirs.



Speed Chart

To determine how a specific pump will operate your cylinder, see the Pump-Cylinder Speed Chart in the 'Yellow Pages'.

Page: 415



Hoses

Enerpac offers a complete line of high quality hydraulic hoses. To ensure the integrity of your system, specify only genuine Enerpac hydraulic hoses.

Page: 128

Used with Cylinder	Reservoir Size (litres)	Manual Valve ¹⁾ Model Number	Valve Function	Model Number	Output Flow Rate ²⁾				Relief Valve Adjustment Range (bar)	Maximum Air Consumption ³⁾ (l/min)
					at 7 bar	at 50 bar	at 350 bar	at 700 bar		
–	4,6	–	–	ZA4004NX	14,0	11,0	1,8	1,3	–	2840
Single-acting	4,6	VM32	Advance / Retract	ZA4204MX	14,0	11,0	1,8	1,3	70 - 700	2840
	6,8	VM33	Advance / Hold /Retract	ZA4308MX	14,0	11,0	1,8	1,3	70 - 700	2840
	9,8	VM33L	Advance / Hold /Retract	ZA4610MX	14,0	11,0	1,8	1,3	70 - 700	2840
Double-acting	4,6	VM43	Advance / Hold /Retract	ZA4404MX	14,0	11,0	1,8	1,3	70 - 700	2840
	6,8	VM43	Advance / Hold /Retract	ZA4408MX	14,0	11,0	1,8	1,3	70 - 700	2840
	9,8	VM43L	Advance / Hold /Retract	ZA4810MX	14,0	11,0	1,8	1,3	70 - 700	2840
	19,8	VM43	Advance / Hold /Retract	ZA4420MX	14,0	11,0	1,8	1,3	70 - 700	2840
	39	VM43	Advance / Hold /Retract	ZA4440MX	14,0	11,0	1,8	1,3	70 - 700	2840

¹⁾ See pages 122-123 for hydraulic symbols of these valves.

²⁾ Actual oil flow will vary with air supply.

³⁾ Dynamic air pressure range: 4 - 7 bar.

Modulair Air Hydraulic Pumps

▼ This is how a ZA4-Series pump model number is built up:



1 Product Type

Z = Pump Class

2 Prime Mover

A = Air motor

3 Flow Group

4 = 1,3 l/min @ 700 bar

4 Valve Type

- 0** = No valve, with cover plate
- 2** = 3/2 manual valve **VM32**
- 3** = 3/3 manual valve **VM33**
- 4** = 4/3 manual valve **VM43**
- 6** = 3/3 manual locking valve **VM33L** with pilot operated check
- 7** = 3/2 manual valve **VM22**
- 8** = 4/3 manual locking valve **VM43L** with pilot operated check.

5 Reservoir Size

- 04** = 4,6 litres
- 08** = 6,8 litres
- 10** = 9,8 litres
- 20** = 19,8 litres
- 40** = 39 litres

6 Valve Operation

- M** = Manual valve
- N** = No valve

7 Motor Voltage

- X** = Not applicable

8 Options

- F** = Return Line Filter
- G** = 1000 bar gauge
- H** = Heat exchanger (on 4,6 and 6,8 litres reservoir only)
- K** = Skid Bar (on 4,6 and 6,8 litres reservoir only)
- N** = No reservoir handles (includes lifting eyes on 9,8, 19,8 and 39 litres)
- R** = Roll Cage

Ordering Example

Model Number: **ZA4208MX-FHK**

ZA4208MX-FHK is an air operated pump with a 3-way, 2-position manual valve, 6,8 litres reservoir, filter, heat exchanger and skid bar.

ZA4 Series



Reservoir Capacity:

4,6 - 39 litres

Flow at Rated Pressure:

1,3 l/min

Air Consumption:

2840 l/min

Maximum Operating Pressure:

700 bar

- ① User adjustable relief valve on all manual valves. 3/8" NPTF on A and B ports; 1/4" NPTF on auxiliary ports.
- ② Air inlet 1/2" NPTF
- ③ Return Line Filter (optional)
- ④ Oil Sight Gauge
- ⑤ Roll Cage (optional)
- ⑥ Oil Drain
- ⑦ Lifting eyes (optional)
- ⑧ Handles
- ⑨ Skid Bar (Modelnr. SBZ4) (optional)

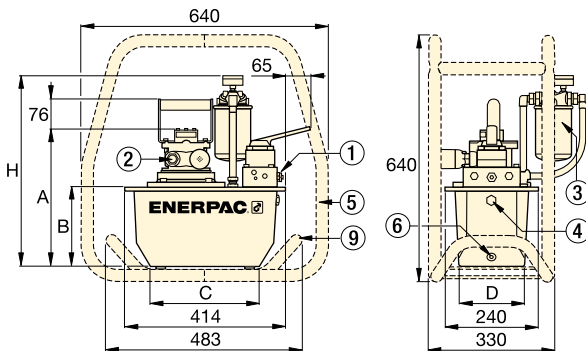

ZA4-Series Pumps with 4,6 - 6,8 litres reservoir

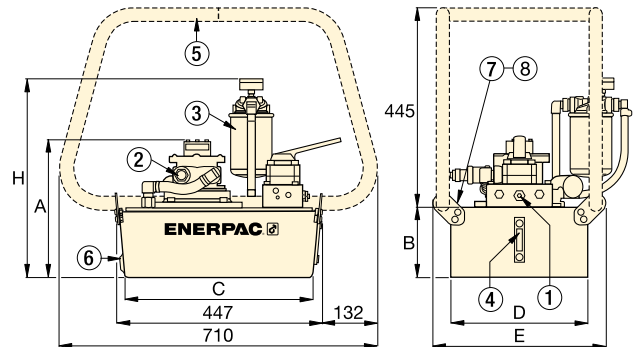

ZA4-Series Pumps with 9,8, 19,8 and 39 litres reservoir

Sound Level (dBA)	Motor Size (kW)	Dimensions (mm)							Model Number
		A	B	C	D	E	H		
80 - 95	3,0	295	142	279	152	-	429	27	ZA4004NX
80 - 95	3,0	295	142	279	152	-	429	30	ZA4204MX
80 - 95	3,0	356	203	279	205	-	490	34	ZA4308MX
80 - 95	3,0	330	180	414	421	500	467	51	ZA4610MX
80 - 95	3,0	295	142	279	152	-	429	31	ZA4404MX
80 - 95	3,0	356	203	279	205	-	490	35	ZA4408MX
80 - 95	3,0	305	155	419	305	384	442	40	ZA4810MX
80 - 95	3,0	330	180	414	421	500	467	52	ZA4420MX
80 - 95	3,0	419	269	399	505	584	556	75	ZA4440MX

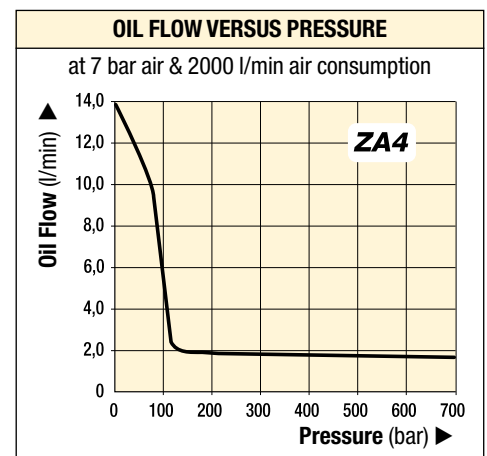

▼ Shown from left to right: ZG6440MX-BFCH, ZG5420MX-B



Z Tough,
Dependable,
Innovative
CLASS

- Features Z-Class high efficiency pump design, higher oil flow and bypass pressure
- Two-speed operation reduces cycle time for improved productivity
- User adjustable relief valve built-in on manual valves. Oil ports on valves are 3/8" NPTF
- Available in three 4-cycle engine sizes: 4,1 kW Honda and 4,8 kW and 9,7 kW Briggs & Stratton
- Full sight oil level glass on all reservoirs allow quick and easy oil level monitoring.

ZG6-Series

- Easy serviceable 9,7 kW, 4-cycle gasoline engine with electric start, pressurized oil and 12 Volt charge output for accessories
- Dual forced air heat exchangers stabilizes hydraulic oil temperature
- Sturdy wheeled cart with collapsible handles.



GA45GC Gauge Adaptor Assembly
Protect yourself from system overloading by simply ordering one part number for a pre-assembled gauge, adaptor block and coupler.

Page: **142**



User Adjustable Relief Valve
All VM-Series directional valves have a user adjustable relief valve to allow the operator to easily set the optimum working pressure.

Page: **122**

▼ SELECTION CHART

Used with Cylinder	Reservoir Size (litres)	Manual Valve ¹⁾ Model Number	Valve Function	Model Number with Roll Cage	Output Flow Rate (l/min)				4-Cycle Engine Type and Size
					at 7 bar	at 50 bar	at 350 bar	at 700 bar	
Single-Acting	9,8	VM33	Advance / Hold / Retract	ZG5310MX-R	11,5	10,7	1,8	1,6	Honda 4,1 kW
	19,8	VM33	Advance / Hold / Retract	ZG5320MX-R	11,5	10,7	1,8	1,6	
Double-Acting	9,8	VM43	Advance / Hold / Retract	ZG5410MX-R	11,5	10,7	1,8	1,6	
	19,8	VM43	Advance / Hold / Retract	ZG5420MX-R	11,5	10,7	1,8	1,6	
Single-Acting	9,8	VM33	Advance / Hold / Retract	ZG5310MX-BR	6,5	6,2	1,8	1,6	Briggs & Stratton 4,8 kW
	19,8	VM33	Advance / Hold / Retract	ZG5320MX-BR	6,5	6,2	1,8	1,6	
Double-Acting	9,8	VM43	Advance / Hold / Retract	ZG5410MX-BR	6,5	6,2	1,8	1,6	
	19,8	VM43	Advance / Hold / Retract	ZG5420MX-BR	6,5	6,2	1,8	1,6	
	39	VM43L	Advance / Hold / Retract	ZG5840MX-BR	6,5	6,2	1,8	1,6	
Double-Acting	39	VM43	Advance / Hold / Retract	ZG6440MX-BCFH	14,7	14,5	3,7	3,3	
	–	–	–	–	–	–	–	–	

¹⁾ See pages 122-123 for hydraulic symbols of these valves.



ZG-Series, Gasoline Pump Performance

Elevation can affect the performance of any gasoline engine. ZG-Series pumps are designed to develop rated performance at elevations up to 1500 m. For applications above this elevation, please consult your Enerpac office.

Optional: Diesel Engine

ZG-Series pumps can also be equipped with a Diesel Engine. Contact Enerpac for details.

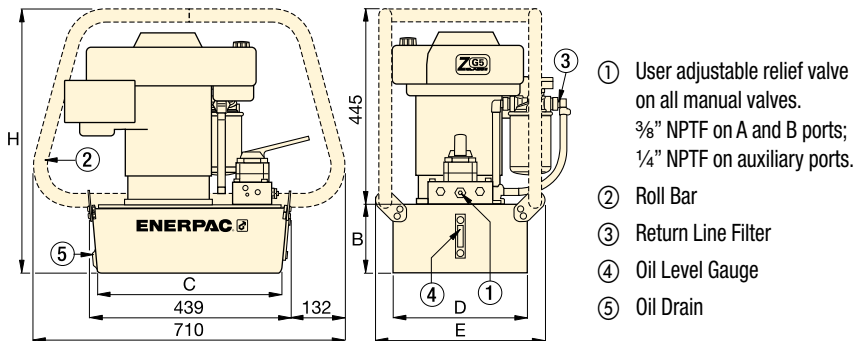

ZG5-Series

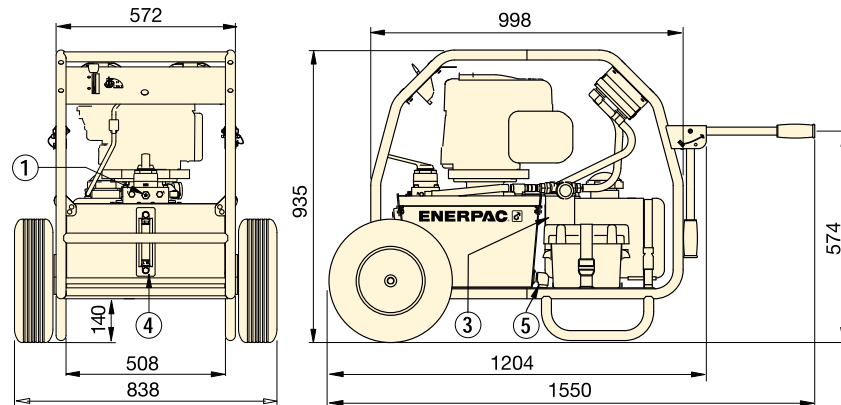

ZG6-Series

Relief Valve Adjustment Range (bar)	Sound Level (dBA)	Dimensions (mm)					Weight (kg)	Model Number with Roll Cage
		B	C	D	E	H		
70 - 700	88 - 93	155	419	305	384	600	52	ZG5310MX-R
		180	414	421	500	625	64	ZG5320MX-R
		155	419	305	384	600	52	ZG5410MX-R
		180	414	421	500	625	64	ZG5420MX-R
70 - 700	88 - 93	155	419	305	384	600	50	ZG5310MX-BR
		180	414	421	500	625	63	ZG5320MX-BR
		155	419	305	384	600	50	ZG5410MX-BR
		180	414	421	500	625	63	ZG5420MX-BR
		269	399	505	557	714	86	ZG5840MX-BR
70 - 700	88 - 93	-	-	-	-	-	152	ZG6440MX-BCFH
		-	-	-	-	-	-	-

ZG Series



Reservoir Capacity:

9,8 - 19,8 - 39 litres

Flow at Rated Pressure:

1,6 - 3,3 l/min

Engine Size:

4,1 - 4,8 - 9,7 kW

Maximum Operating Pressure:

700 bar



High Pressure Hoses

Enerpac offers a complete line of high quality hydraulic hoses. To ensure the integrity of your system, specify only genuine Enerpac hydraulic hoses.

Page: 128



Speed Chart

To determine how a specific pump will operate your cylinder, see the Pump-Cylinder Speed Chart in the 'Yellow Pages'.

Page: 415

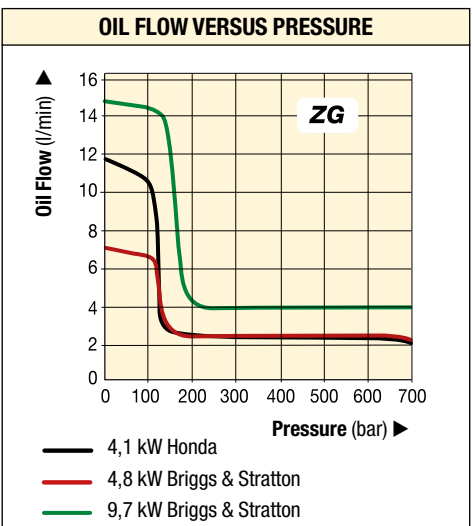

Enerpac offers a wide variety of hydraulic pumps for all your custom needs. Still, many applications require a customized pump to operate the system.

Hydraulic pumps are at the heart of any hydraulic system. Different systems require different flow, pressure and control.

Enerpac offers a wide variety of hydraulic pumps from small hand-operated pumps to large gasoline-powered pumps.

Still, many applications require a customized pump to operate the system. These may include larger reservoir capacity, custom valve configurations or added electrical controls. Enerpac also specializes in power units and controls used for synchronous lifting/lowering of multiple jacking points.



◀ Private-label hand or foot pumps with fire-resistant oil and special exterior paint.



◀ XC-Series Cordless Pump with custom black shroud for private-label OEM customer to be used with a variety of hand held hydraulic tools.



◀ Electric pump with large cooler and controls for high-temperature applications.

Overview Custom Pumps



▲ Custom hydraulic pumps for a bridge deck launching system.

CUSTOMIZABLE FEATURES:



- Reservoir and Frame
- Valves
- Controls
- Oil
- Seals
- Pressure and Flow
- Coolers and Heaters
- Paint
- Motor Type

Directional Control Valves

Energac hydraulic valves are available in a wide variety of models and configurations.

Whatever your requirements... directional control, flow control, or pressure control... you can be sure that Energac has the correct valve to match your application exactly.

Designed and manufactured for safe operation up to 700 bar, the range of Energac valves allows for direct pump mounting, remote mounting, manual or solenoid actuation, and in-line installation, giving you flexible solutions to control your hydraulic system.

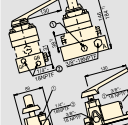
Valve Type	Series		Page
Pump Mounted Manual and Solenoid Directional Control Valves	VM VE		122 ▶
Remote Mounted Manual Directional Control Valves	VC		124 ▶
Valve Dimensions	VM VE VC		125 ▶



Pressure & Flow Control Valves

For more hydraulic system control with pressure relief valves, shut-off valves, check valves and sequence valves see our "System Components".

Page: 144



Valving Help

See Basic System Set-Up and Valve Information in our 'Yellow Pages'.

Page: 405

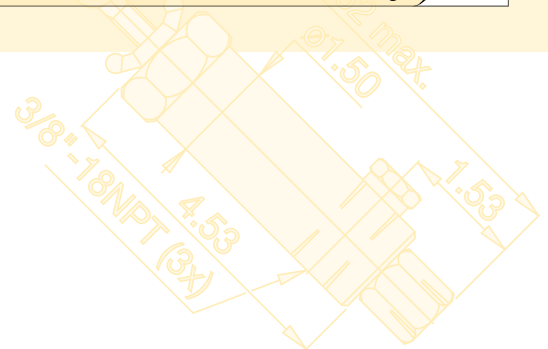

▼ Shown from left to right: VM32, VE33, VM33, VM43L, VE43



- Advance/Retract and Advance/Hold/Retract operation of single- and double-acting cylinders and tools
- Manual or solenoid operation
- Pump mounting will retrofit on most Enerpac pumps
- Available “locking” option on VM-Series valves for load-holding applications
- Standard “locking” feature on VE-Series 3-position valves
- User adjustable relief valve allows the operator to easily set the working pressure.

Venturi Valve Technology

- For fast return of single-acting gravity and spring return cylinders
- Available as manual or solenoid valve on ZU4- and ZE-Series electric pumps
- Retrofit Venturi valve kits for field installation on existing ZU4- and ZE-Series electric pumps.



Adjustable relief valve

All valves feature several gauge ports for “system”, A port and B port pressure monitoring. User adjustable relief valves are included on all models to allow the operator to easily set the optimum working pressure for each application.

VM33 and VE43 valves include “System Check” feature, for more precise pressure holding and improved system control.

The VM33 has improved porting which provides faster cylinder retraction while motor is running.

Locking Valves

For applications that require positive load holding, VM-Series valves (except VM22 and VM32) are available with a pilot-operated check valve. This option provides hydraulic locking of the load until the valve is shifted into the retract position.

Reliable Control of Single and Double-Acting Cylinders and Tools

Valve Operation	Used with Cylinder	Valve Type	
Manual	Single-acting	3-Way, 2-Position	
Manual	Single-acting	3-Way, 2-Position	
Manual	Single-acting	3-Way, 3-Position, Tandem Center	
Manual	Single-acting	3-Way, 3-Position, Tandem Center, Venturi Return Assist	
Manual	Double-acting	4-Way, 3-Position, Tandem Center	
Manual	Single-acting	3-Way, 3-Position, Tandem Center, Locking	
Manual	Double-acting	4-Way, 3-Position, Tandem Center, Locking	
Solenoid 24 VDC	Single-acting	3-Way, 2-Position	
Solenoid 24 VDC	Single-acting	3-Way, 2-Position, Dump	
Solenoid 24 VDC	Single-acting	3-Way, 3-Position, Tandem Center, Venturi Return Assist	
Solenoid 24 VDC	Single-acting	3-Way, 3-Position, Tandem Center	
Solenoid 24 VDC	Double-acting	4-Way, 3-Position, Tandem Center	

For remote valve information, see page 124.
See page 125 for valve dimensions.

Pump Mounted Directional Control Valves

VM VE Series



Maximum Flow Capacity:

17 l/min

Maximum Operating Pressure:

700 bar

Model Number	Hydraulic Symbol	Schematic Flowpath			 (kg)
		Advance	Neutral	Retract	
VM22					2,5
VM32					2,5
VM33					3,0
VM33VAC					3,5
VM43					3,1
VM33L					4,8
VM43L					4,9
VE32					3,9
VE32D					3,9
VE33VAC					10,0
VE33					9,3
VE43					9,3



Assisted Return Pumps with Venturi Valve Technology

To improve productivity and plunger retraction, Enerpac offers valve configurations designed to

accelerate your cylinder retraction speeds, ZU4 and ZE-Series pumps feature **Venturi Valve Technology** to facilitate the faster return of single-acting gravity and spring return cylinders.

See valve type in ZU4 and ZE-pump ordering matrix on pages 100 and 106.

Venturi Valve Retrofit Kits

For field installation on existing ZU4, ZE and ZA-Series pumps, Retrofit Kits are available for manual and solenoid operated valves.

For valve model	For valve operation	Retrofit Kit Model Nr.
VM33, VM33L	Manual	VM33RVK
VE33	Solenoid	VUV5



Spring Centred Valve Kits

VM and VC-Series manual 3-position valves can be easily converted into spring centred valves. With these retro-fit kits the

handle will automatically move into the neutral valve position when released.

For valve model	Model Number
VM33, VM43	VMC3343K
VM33L, VM43L	VMC3343KL
VC3, VC15, VC4, VC20	VMC34K
VC3L, VC15L, VC4L, VC20L	VMC34KL

▼ Shown from left to right: VC20, VC4L



Remote Control of Single and Double-Acting Cylinders and Tools



Locking Valves

For applications that require positive load holding, VC-Series valves are available with a pilot-operated check valve. This option provides hydraulic locking of the load until the valve is shifted into the retract position.

- Advance/Hold/Retract operation for use with single-acting or double-acting cylinders and tools
- Return line kit included with remote valves.

Valve Operation	Used with Cylinder	Valve Type	Model Number	Hydraulic Symbol	Schematic Flowpath			(kg)
					Advance	Hold	Retract	
Manual	Single-Acting	3-Way, 3-Position, Tandem Center	VC3					2,9
Manual	Single-Acting	3-Way, 3-Position, Tandem Center, Locking	VC3L					4,7
Manual	Single-Acting	3-Way, 3-Position, Closed Center	VC15					2,9
Manual	Single-Acting	3-Way, 3-Position, Closed Center, Locking	VC15L					4,7
Manual	Double-Acting	4-Way, 3-Position, Tandem Center	VC4					2,9
Manual	Double-Acting	4-Way, 3-Position, Tandem Center, Locking	VC4L					4,7
Manual	Double-Acting	4-Way, 3-Position, Closed Center	VC20					2,9
Manual	Double-Acting	4-Way, 3-Position, Closed Center, Locking	VC20L					4,7

Directional Control Valves Dimensions

Pump Mounted Directional Control Valves

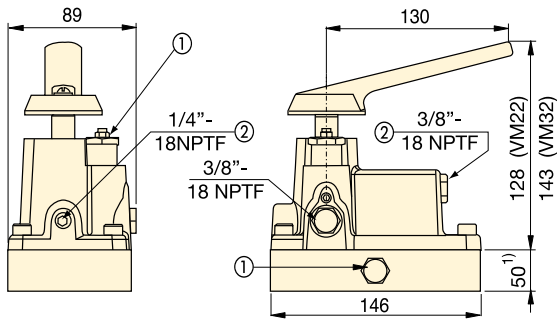

VM22, VM32

¹⁾ VM22 only

- ① User Adjustable Relief Valve
- ② Auxiliary Port

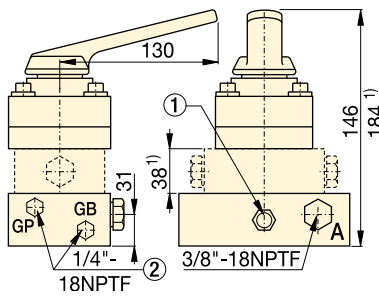

VM33, VM33L, VM33VAC, VM43, VM43L

¹⁾ VM33VAC, VM33L and VM43L only

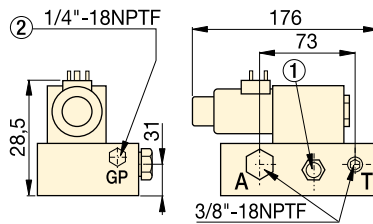

VE32D

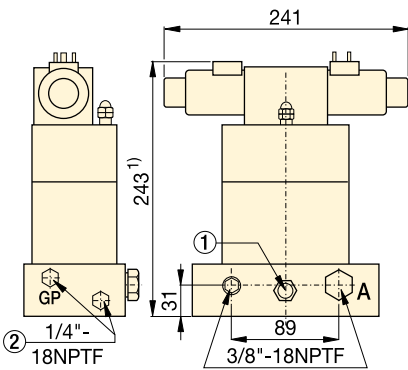

VE33, VE33VAC

¹⁾ VE33VAC is 38 mm higher: 281 mm

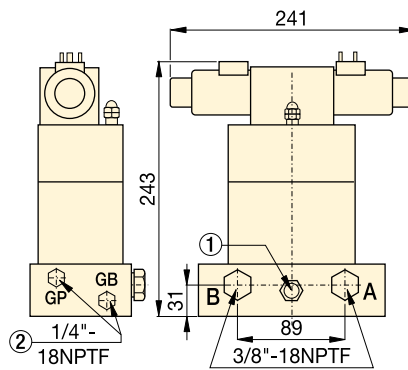

VE43

Remote Manual Directional Control Valves

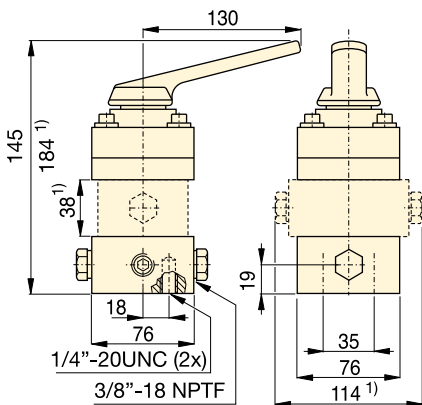

VC3, VC3L, VC15, VC15L

VC4, VC4L, VC20, VC20L

¹⁾ VC3L, VC15L, VC4L and VC20L only

VM VE VC Series



Maximum Flow Capacity:

17 l/min

Maximum Operating Pressure:

700 bar



Spring Centred Valve Kits

VM and VC-Series manual 3-position valves can be easily converted into spring centred valves. With these retro-fit kits the

handle will automatically move into the neutral valve position when released.

For valve models	Model Number
VM33, VM43	VMC3343K
VM33L, VM43L	VMC3343KL
VC3, VC15, VC4, VC20	VMC34K
VC3L, VC15L, VC4L, VC20L	VMC34KL



Gauges

Minimize the risk of overloading and ensure long, dependable service from your equipment. Refer to the System Components

Section for a full range of gauges.

Page: 127



Fittings

For additional fittings see the fitting page of the System Components section in this catalogue.

Page: 133



Valving Help

See Basic System Set-Up and Valve Information in our 'Yellow Pages'.

Page: 416

Enerpac System Components:

All the additional elements you need to complete your high pressure hydraulic system and get started.

Engineered to work with your Enerpac cylinders, pumps and tools, all Enerpac components are designed to the most exacting standards.

With this complete line of hydraulic hoses, couplers, fittings, manifolds, oil and gauges, Enerpac has the accessories to complement your system and ensure the efficient operation, long life and safety of your hydraulic equipment.



Yellow Pages

For sample system set-ups and how to correctly specify your system components, please view the Enerpac "Yellow Pages" section in this catalogue.

Page: 404











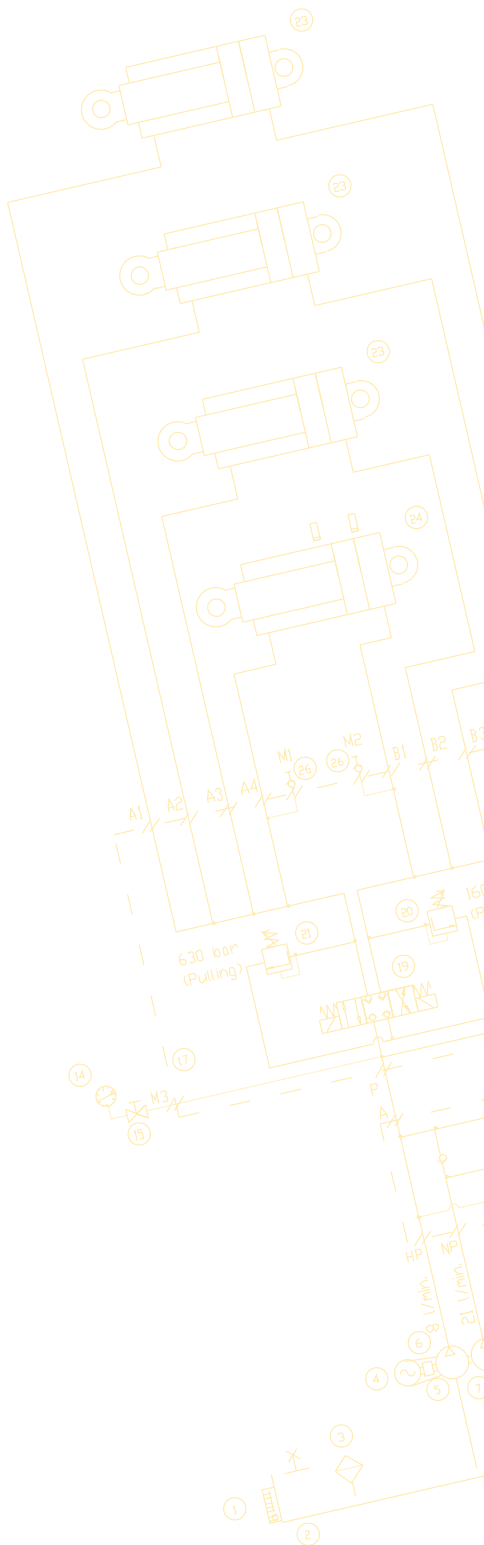







Maintain System Integrity

Use Enerpac System Components, designed to interface with Enerpac cylinders, pumps and tools to ensure your system operates at peak performance.



System Components & Control Valves Overview



Component Type	Series		Page
High Pressure Hoses	H700		128 ▶
Couplers	A, C, F, T		130 ▶
Hydraulic Oil	HF		132 ▶
Manifolds	A		132 ▶
Control Manifolds	AM		132 ▶
4-Way Manifold Assemblies with Gauges	AMGC		132 ▶
Fittings	BFZ, FZ XSC		133 ▶
Split-Flow Manifolds	SFM		134 ▶
Force Gauges Pressure Gauges	GF GP		136 ▶
Pressure Gauges, glycerine filled Pressure Gauges, dry	G H		138 ▶
Test System Gauges	T		140 ▶
Digital Hydraulic Pressure Gauge	DGR		141 ▶
Gauge Adaptor Assembly	GA45		142 ▶
Gauge Adaptors Swivel Adaptor, Needle Valves	GA NV, V		143 ▶
Pressure and Flow Control Valves	V		144 ▶

▼ HC7206



Thermo-Plastic Safety Hoses (H700-Series)

- For demanding applications, featuring a 4:1 safety factor
- Maximum working pressure of 700 bar
- Outside jacket is polyurethane, to provide maximum abrasion resistance
- Exhibits low volumetric expansion under pressure to enhance overall system efficiency
- Vinyl strain relief guard on both ends of hose to improve life and durability on all models.

▼ To prevent back pressure and to increase cylinder retraction speed, when using long hoses with single-acting cylinders, the Enerpac HC7300-Series of hoses with increased internal diameter is the best choice.



Safety and Quality



To ensure the integrity of your system, specify only Enerpac hydraulic hoses.

WARNING !

- Do not exceed 700 bar maximum pressure.
- Do not handle hoses which are under pressure.

More safety instructions in our 'Yellow pages'.

Page: 406

▼ Hose End Couplings

1/4" NPTF	
3/8" NPTF	
A604	
A630	
AH604	
AH630	
C604	
CH604	

High Pressure Hydraulic Hoses



Hose Oil Capacity

When using greater hose lengths, it is sometimes necessary to fill the pump reservoir after filling the hoses.

To determine the hose oil capacity, use the following:

For 6,4 mm inside diameter hoses:

Capacity (cm³) = 32,1699 x Length (m)

For 9,7 mm inside diameter hoses:

Capacity (cm³) = 73,8981 x Length (m)

H700 Series



Inside Diameter:

6,4 - 9,7 mm

Length:

0,6 - 15 m

Maximum Operating Pressure:

700 bar

Internal Diameter (mm)	Hose End Assemblies and Couplers *		Hose Length (m)	Model Number	Weight (kg)		
	End one	End two					
6,4	1/4" NPTF		-	-	-		
				-	-		
		A630	1,8	HB7206QB	1,1		
				-	-		
	3/8" NPTF	CH604		1,8	HC7206Q	1,0	
				0,6	H7202	0,5	
				0,9	H7203	0,7	
				1,8	H7206	0,9	
				3,0	H7210	1,4	
				6,1	H7220	2,8	
				9,1	H7230	4,5	
				15	H7250	7,0	
		A604		-	-	-	
				1,8	HA7206B	1,1	
				-	-	-	
				-	-	-	
			AH604		-	-	-
					1,8	HA7206	1,0
	AH630		3,0	HA7210	1,5		
			1,8	HB7206	1,0		
	C604		0,9	HC7203B	1,0		
			1,8	HC7206B	1,3		
			3,0	HC7210B	1,8		
			0,9	HC7203	0,8		
CH604		1,8	HC7206	1,0			
		3,0	HC7210	1,5			
		6,1	HC7220	2,9			
		1,8	HC7206C	1,1			
CH604	CH604		6,1	HC7220C	3,0		
			15	HC7250C	7,0		
			1,8	H7306	1,6		
9,7	3/8" NPTF	3/8" NPTF	3,0	H7310	2,4		
			6,1	H7320	4,5		
			9,1	H7330	7,3		
			15	H7350	11,5		
		CH604		1,8	HC7306	1,7	
				3,0	HC7310	2,5	
				6,1	HC7320	5,1	
				1,8	H7306	1,6	

* For technical information on couplers see next page.



GA45GC Gauge Adaptor

Protect yourself from system overloading by simply ordering one part number for a pre-assembled gauge, adaptor block and coupler.

Page: 142



Torque Wrench Hoses

Use Enerpac THQ-Series twin safety hoses with double-acting wrenches to ensure the integrity of your hydraulic system.

Page: 257



Fittings

For additional fittings see the fitting page of the System Components section.

Page: 133



Premium Hydraulic Oil

Use only genuine Enerpac hydraulic oil. Wrong fluid can destroy seals and pump and will render your warranty null and void your guarantee.

Page: 132

▼ Shown: FH604, FR400, AR630, C604, AH604, AR400



3/8" High Flow Couplers

- Standard equipment on most Enerpac cylinders
- Recommended for use on all Enerpac pumps and cylinders where space and porting permits
- Includes "2-in-1" dust cap for use on male and female couplers.

3/8" High Pressure 'Flush-face' Couplers

- Featuring "Push-to-connect" operation, to guarantee good connection every time
- Flush-face, zero-leak operation for minimal spillage and reduced pressure drop
- HTMA * recognized for safety and performance
- Will not interchange with low pressure couplers.

3/8" Regular Spee-D-Couplers®

- For medium duty applications with hand pumps
- Includes female aluminium dust cap.

1/4" Regular Couplers

- For use with small cylinders and hand pumps
- Includes female aluminium dust cap.

1/4" Spin-on Torque Wrench Couplers

- For use with 700 bar S, W, RSL, DSX and HMT-Series torque wrenches, THQ-Series hoses and 700 bar torque pumps.

* Hydraulic Tool Manufacturers Association.

Quick Connection of Hydraulic Lines

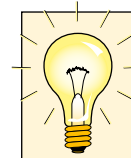

Thread sealer

To seal NPTF threads use one of the new anaerobic thread sealers or Teflon paste. When using Teflon Tape, apply the tape one thread from the end of a fitting to prevent it from winding up in the hydraulic system.



WARNING!

Couplers should be pressurized only when completely connected and should not be coupled or uncoupled when pressurized.

More safety instructions in our 'Yellow Pages'.

Page: 406



F-Series

Flush-faced couplers provide reduced pressure drop versus other types and are preferred in dirty, grimy construction and mining environments due to easy clean, non-dirt trapping faces.

▼ With the use of Enerpac high flow couplers, hoses are easily installed for multiple hydraulic line connections in this 34 points PLC-controlled lifting system.



Hydraulic Couplers



CT604 Safety Tool

Use the Enerpac CT604 to relieve hydraulic back pressure by safely bleeding the hydraulic coupler.

NOTE: For use on CR400 and CH604 700 bar High-Flow Couplers only

Minimize injuries from projectile parts and under-skin hydraulic fluid injections by eliminating unsafe coupler bleeding practices. The CT604 is Enerpac-engineering safe for use at 700 bar.

A, C, F, T Series



Maximum Flow Capacity:
7,6 - 40,0 l/min

Thread:
1/4" - 3/8" NPTF

Maximum Operating Pressure:
700 bar

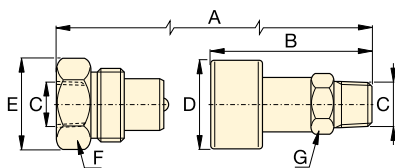

C604

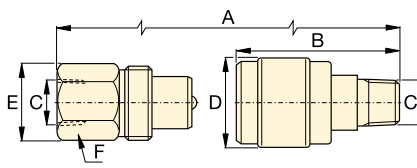

**A604
A630**

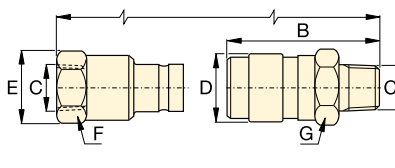

F604

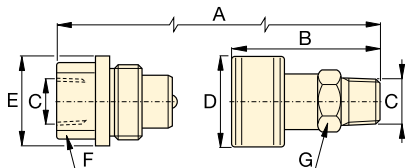

T630

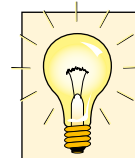





Metal Dust Caps

Steel dust caps are available for the C604 series couplers.

Order model number:

CD411M for female half

CD415M for male half

Maximum Flow Capacity (l/min)	Coupler Type	Model Numbers			Dimensions (mm)							Dust Cap(s) Modelnr.
		Complete Set	Female Half	Male Half	A*	B	C	D	E	F	G	
35	700 bar High-Flow Coupler 	C604	CR400	CH604	83	64	3/8" NPTF	35	36	32	25	(2x) CD411
40	700 bar Flush-Face Coupler 	F604	FR400	FH604	111	72	3/8" NPTF	31	31	27	29	-
7,6	700 bar Regular Spee-D-Coupler® 	A604	AR400	AH604	77	42	3/8" NPTF	28	26	23	19	Z410 female only
7,6	700 bar Regular Coupler 	A630	AR630	AH630	66	35	1/4" NPTF	22	20	19	15	Z640 female only
11,4	700 bar Spin-on Coupler 	T630	TR630	TH630	73	60	1/4" NPTF	29	29	19	21	-

* Value A is total length when male and female half are connected.

▼ Shown: HF102L, HF105L



- Maximum pump volumetric efficiency
- Maximum internal heat transfer
- Prevents pump cavitation
- Additives prevent rust, oxidation and sludge
- High viscosity index
- Maximum film protective lubricity.

The Genuine Range

Hydraulic Oil

Contents	Model Number	Use only genuine Enerpac Hydraulic Oil. The use of any other fluid will render your Enerpac warranty null and void.
5 litres	HF105L	
20 litres	HF102L	
205 litres	HF104L	

▼ OIL SPECIFICATION CHART

Viscosity Index	100 min
Viscosity (cSt @ 40 °C)	32
API Gravity	31-33
Density (cSt @ 15 °C)	875
Flash point	204 °C
Pour point	-32 °C
Colour	Blue
Working Temperature Range	0 - 60 °C
Ideal working temperature	40 °C

700 bar Manifolds

Description	Model Number	Dimensions (mm)
7-port Manifold, short	A64	
7-port Manifold, long allows direct mounting of control valves to the manifold.	A65	
6-port Manifold, hexagon Plugs furnished for all ports 3/8"-18 NPTF.	A66	
Control Manifolds For control of 2 or 4 single-acting cylinders simultaneously. AM21 with 5 ports 3/8"NPTF. AM41 with 7 ports 3/8"NPTF.	AM21 AM41	
4-way Manifold Assemblies CR400 female couplers on all 3/8"NPTF ports. With glycerine filled pressure gauges, shut-off valves and robust protection frame. AMGC41 for 4x s/a cylinders AMGC42 for 4x d/a cylinders.	AMGC41 AMGC42	

Hydraulic Oil, Manifolds and Fittings







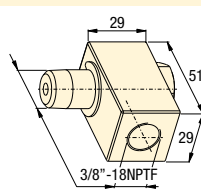





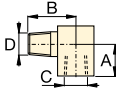

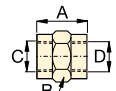

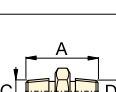

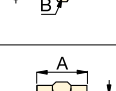

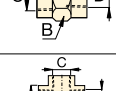

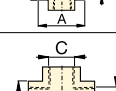

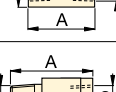

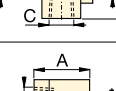

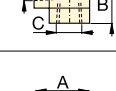

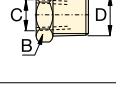

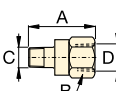
3/8" Swivel Connector

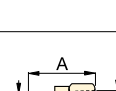
360 degree swivel coupler for optimal orientation of the hydraulic connection on cylinders, pumps and hoses.
Order Model Number. XSC1

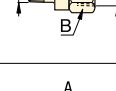

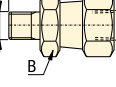
HF A, AM BFZ FZ Series



700 bar Fittings		Model Number	Dimensions (mm)				Diagram	
			A	B	C	D		
Street Elbow			FZ1616	23	33	3/8"-18 NPTF	3/8"-18 NPTF	
From: 3/8"-NPTF Male	To: 3/8"-NPTF Female							
Reducing Connector			FZ1615	28	25	3/8"-18 NPTF	1/4"-18 NPTF	
From: 3/8"-NPTF Female	To: 1/4"-NPTF Female							
			FZ1625	47	29	1/2"-14 NPTF	3/8"-18 NPTF	
From: 1/2"-NPTF Female	To: 3/8"-NPTF Female							
Hexagon Nipple			FZ1608	38	16	1/4"-18 NPTF	1/4"-18 NPTF	
From: 1/4"-NPTF	To: 1/4"-NPTF							
From: 3/8"-NPTF	To: 3/8"-NPTF							
From: 3/8"-NPTF	To: 3/8"-NPTF							
Coupling			FZ1614	29	23	3/8"-18 NPTF	3/8"-18 NPTF	
From: 3/8"-NPTF	To: 3/8"-NPTF							
			FZ1605	29	19	1/4"-18 NPTF	1/4"-18 NPTF	
From: 1/4"-NPTF	To: 1/4"-NPTF							
Cross			FZ1613	45	25	3/8"-18 NPTF	-	
From: 3/8"-NPTF Female	To: 3/8"-NPTF Female							
Tee			FZ1612	45	25	3/8"-18 NPTF	-	
From: 3/8"-NPTF	To: 3/8"-NPTF							
From: 1/4"-NPTF	To: 1/4"-NPTF							
			FZ1637	45	24	1/4"-18 NPTF	-	
From: 1/4"-NPTF	To: 1/4"-NPTF							
Street Tee			BFZ16312	56	26	3/8"-18 NPTF	3/8"-18 NPTF	
From: 3/8"-NPTF Female	To: 3/8"-NPTF Male							
Elbow			FZ1610	33	20	3/8"-18 NPTF	-	
From: 3/8"-NPTF	To: 3/8"-NPTF							
			FZ1638	36	24	1/4"-18 NPTF	-	
From: 1/4"-NPTF	To: 1/4"-NPTF							
Reducer			FZ1630	19	19	1/4"-18 NPTF	3/8"-18 NPTF	
From: 3/8"-NPTF	To: 1/4"-NPTF							
From: 1/4"-NPTF	To: 1/2"-NPTF							
			BFZ16301	19	19	G1/4"	3/8"-18 NPTF	
From: 3/8"-NPTF	To: G1/4"							
Adaptor			BFZ-16411	35	19	1/4"-18 NPTF	G1/4"	
From: G1/4"	To: 1/4"-NPTF							
From: G1/4"	To: 1/8"-NPTF							
From: G3/8"	To: 1/4"-NPTF							
			BFZ-16421	31	19	1/8"-27 NPTF	G1/4"	
From: G3/8"	To: 1/4"-NPTF							
From: G3/8"	To: 3/8"-NPTF							
			BFZ-16323	43	24	1/4"-18 NPTF	G3/8"	
From: G3/8"	To: 3/8"-NPTF							
Adaptor			FZ1055	44	23	1/4"-18 NPTF	3/8"-18 NPTF	
From: 1/4"-NPTF	To: 3/8"-NPTF							
From: 1/4"-NPTF	To: 1/8"-NPTF							
			FZ1642	30	19	1/8"-27 NPTF	1/4"-18 NPTF	
From: 1/2"-NPTF	To: 3/8"-NPTF							
			FZ1634	42	28	3/8"-18 NPTF	1/2"-18 NPTF	
From: 1/2"-NPTF	To: 3/8"-NPTF							
Swivel Fitting			FZ1660	40	22	3/8"-18 NPTF	3/8"-18 NPTF	
From: 3/8"-NPTF Male	To: 3/8"-NPTF Female							

▼ Shown from left to right: SFM41, SFM42 Split-Flow Manifolds



- Split-Flow Manifolds improve safety, precision and control in lifting and lowering operations
- Pressure gauge, flow control valve in each outlet port; CR400 couplers installed in each inlet and outlet port
- Regulates both advance and retract speeds: lifting and lowering
- 1 inlet, 4 outlets. Maximum of 4 cylinders per manifold: SFM41 for single-acting cylinders, SFM42 for double-acting cylinders
- Minimum pump oil flow: 1,40 l/min to deliver 0,15 - 0,25 l/min per cylinder
- Maximum difference among outlets: 10% of the stroke (in 150 mm)
- More cylinders can be controlled simultaneously by connecting several SFM-models parallel.



Improved safety on basic simultaneous lifting applications



Pressure Gauges G2535L

Glycerine filled pressure gauges are installed in each outlet pressure line to monitor the pressure of each cylinder.



Optimum Performance

Minimum pump oil flow must be 1,40 l/min to deliver 0,15-0,25 l/min per cylinder. Enerpac recommends to use

Z-Class electric or gasoline pumps from the ZE5 and ZG-Series.



SFP-Series, Split-Flow Pumps

When a higher accuracy is required across cylinder strokes in a multi-point lifting or lowering application Enerpac recommends

to use the SFP-Series Split-Flow Pumps.



Contact Enerpac!

Contact the Enerpac office nearest to you for advice and technical assistance in the layout of your ideal Lifting

System or visit us at: www.enerpac.com.

Or ask Enerpac for assistance:

enerpac.com/contact-us

◀ To repair the foundation, silos needed to be lifted, levelled and structurally supported. Powered by a ZE5-Series electric pump the split-flow manifold used to operate multiple hydraulic cylinders.

Split-Flow Manifolds



Split-Flow Manifolds

The SFM-Series offer an economical solution for basic multi-point simultaneous lifting applications and enables a single operator to control a maximum of 4 lifting points from one manifold.

The Split-Flow Manifolds are equipped with pressure compensated flow control valves, to preset and limit advance and retract speed of each cylinder, allowing to move up to 4 cylinders simultaneously.

The SFM-Series provide more lifting and lowering control compared to AM-Series Control Manifolds. See flow control valve adjustments table below.

Minimum pump oil flow must be 1,40 l/min (ZE5-Series pumps) to deliver 0,15 - 0,25 l/min per cylinder. Several SFM-models can be connected parallel to the same pump to allow simultaneous operation of 8, 12 or 16 cylinders.

Higher flow pumps are required to achieve faster advance speeds. A 20% higher oil flow must be considered for a proper speed compensation.

Example : when using 4 cylinders: if oil flow of 0,45 l/min is required per cylinder, the pump oil flow must be:
 $4 \times 0,45 = 1,8 \text{ l/min} + 20\% = 2,16 \text{ l/min}$.

The maximum stroke deviation between the cylinders can reach up to 10% in 150 mm depending on the cylinder pressure. Oil flow adjustment is also possible during cylinder operation by fine tuning using the flow control valves.

All cylinders connected to the SFM-manifold must have the same capacity (effective area). Both advance and retract speed are limited by the same valves. Use hoses of the same lengths to improve the accuracy of the hydraulic system. Improved precision when difference of pressures among the cylinders is within 200 bar.

SFM Series



Inlet Connection:
1x power pump

Outlet Connections:
Max. 4 cylinders

Minimum Pump Flow Required:
1,40 l/min

Maximum Operating Pressure:
700 bar



Load Holding

Use **V66 check valves** for load holding applications with single-acting cylinders.

Page: 145



Hoses

Energac offers a complete line of high-quality hydraulic hoses. To ensure the integrity of your system, specify only Energac hydraulic hoses. Energac recommends to use hoses of the same lengths between the SFM and cylinders to improve system accuracy.



Flow Control Valves

The Split-Flow Manifold has pressure compensated flow control valves installed in each outlet line. The oil flow from the SFM-Manifold to each cylinder can be adjusted by turning the knob on the valve.

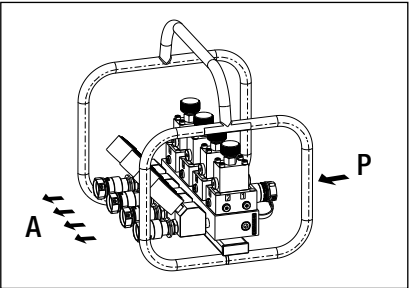
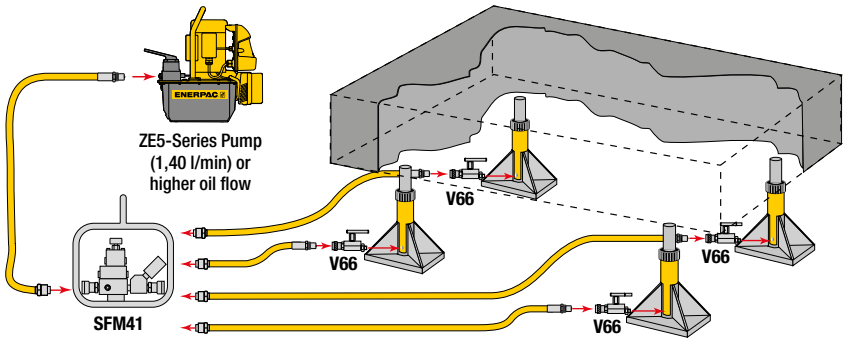

SFM41

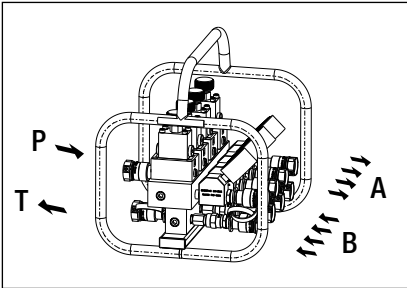

SFM42

▼ SPLIT-FLOW MANIFOLDS

For use with cylinders	Model Number	Minimum oil flow to each cylinder (l/min)	Female couplers included	Dimensions L x W x H (mm)	(kg)
4x single-acting	SFM41	0,15	CR400	370 x 335 x 375	24
4x double-acting	SFM42	0,15	CR400	370 x 335 x 375	30

Flow Control Valve Adjustments			
Number of Knob Turns	Oil Flow (l/min)	Number of Knob Turns	Oil Flow (l/min)
1/2	0,15	3	1,9
1	0,45	3 1/2	3,6
1 1/2	0,75	4	5,6
2	0,90	4 1/2	8,3
2 1/2	1,3	Open	10,3

▼ Shown from left to right: GF230B, GF835B, GP10S



- **GF-series gauges:** calibrated with dual scale reading for pressure (bar) and force (kN)
- **GF-series gauges:** all pressure sensing parts are sealed and dampened by glycerine for long life
- **GP-series gauges:** calibrated with dual scale reading for pressure in bar and psi
- **Excellent readability:** gauge face dimensions 100 mm
- **Fast, easy installation**
- **Stainless steel gauge cases for corrosion resistance.**

▼ A GP10S gauge is used on this press to check the hydraulic pressure required to bend flat steel bar.



Visual Reference for System Pressure and Force



Auto-Damper Valve V10

For automatic control of gauge fluctuations, the V10 Auto-Damper Valve controls the movement of the gauge needle by restricting oil flow in and out of the gauge. No adjustments needed.

Page: 144



Snubber Valve V91

Infinitely adjustable for metering oil out of a gauge. The V91 Snubber Valve is also suitable as a shut-off valve to protect the gauge during high cycle applications.

Page: 144

Used With	
	All cylinders
	All cylinders
	5 ton RC, RSM-cylinders
	10 ton RC, RCS, RSM-cylinders
	All 25 ton RC-cylinders
	All 50 ton RC, RR-cylinders
	13 ton RCH-Series
	RCS201, 302
	RCS502, 1002
	RCH202, 302, 603
	25, 30, 50 ton RC, RCS, RSM, RR
	75 and 95 ton RC, RR-cylinders
	150 and 200 ton RR-cylinders
	10 ton VLP Presses
	25 ton XLP Presses
	50 ton XLP, BPR Presses
100 ton VLP, BPR Presses	
200 ton VLP, BPR Presses	

Hydraulic Force & Pressure Gauges



Maximum Indicator Pointer

Indicator retains peak readings of pressure or force generated by the system.

Can easily be installed on GP and H-Series gauges. Order model nr: **BSA881**.



Pressure Gauges

To measure the input pressure into cylinders or high pressure systems. Also for all testing applications.

Force Gauges

To measure external load supported by a cylinder or jack in kN. For pressing parts together under pre-determined loads, weighing, testing, etc.

GP-Series are dry gauges.

GF-Series are glycerine filled gauges.

GF GP Series



Pressure Range:

0 - 1000 bar

Force Range:

0 - 2000 kN

Gauge Face Diameter:

100 mm

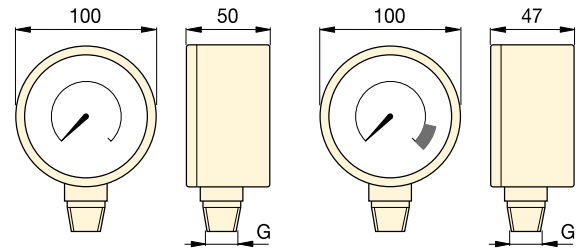

Accuracy, % of full scale:

± 1%



GP-series

GF-series

Gauge Type and Calibration				Units per Division	Model Number *	Thread G	Gauge Adaptor		
							 143		
bar	psi	bar	kN			Required			
						GA1	GA2	GA3	
0-700	0-10.000	-	-	10 bar, 100 psi	GP10S	1/2" NPTF	●	●	
0-1000	0-15.000	-	-	10 bar, 200 psi	GP15S	1/2" NPTF	●	●	
-	-	0-700	0-45	10 bar, 0,5 kN	GF5B	1/2" NPTF	●	●	
-	-	0-700	0-100	10 bar, 1 kN	GF10B	1/2" NPTF	●	●	
-	-	0-700	0-232	10 bar, 2 kN	GF20B	1/2" NPTF	●	●	
-	-	0-700	0-500	10 bar, 5 kN	GF50B	1/2" NPTF	●	●	
-	-	0-700	0-124	10 bar, 1 kN	GF120B	1/2" NPTF	●	●	
-	-	0-700	0-175/275	10 bar, 2 + 5 kN	GF230B	1/2" NPTF	●	●	
-	-	0-700	0-450/900	10 bar, 5 + 10 kN	GF510B	1/2" NPTF	●	●	
-	-	0-700	0-210/320/570	10 bar, 5 kN	GF813B	1/4" NPTF			●
-	-	0-700	0-232/300/500	10 bar, 5 kN	GF835B	1/4" NPTF			●
-	-	0-700	0-720/930	10 bar, 10 kN	GF871B	1/4" NPTF			●
-	-	0-700	0-1400/2000	10 bar, 25 kN	GF200B	1/4" NPTF			●
-	-	0-700	0-100	10 bar, 1 kN	GF10B	1/2" NPTF	●	●	
-	-	0-700	0-232	10 bar, 2 kN	GF20B	1/2" NPTF	●	●	
-	-	0-700	0-500	10 bar, 5 kN	GF50B	1/2" NPTF	●	●	
-	-	0-700	0-720/930	10 bar, 10 kN	GF871B	1/4" NPTF			●
-	-	0-700	0-1400/2000	10 bar, 25 kN	GF200B	1/4" NPTF			●

* GF-Series Force gauges with imperial scale reading (psi, lbs) are available by changing the suffix 'B' into 'P'.

▼ Shown from left to right: H4049L, G2534R, G4089L, G2535L, G4040L



Visual Reference of System Pressure

Glycerine Filled (G-Series)

- Dual scale reading calibrated in bar and psi
- All pressure sensing parts sealed and dampened by glycerine for long life
- Includes safety blow-out disk and pressure equalizing membrane
- Gauge snubbers or needle valves recommended for high cycle applications.

High Cycle Dry Gauges (H-Series)

- Dual scale reading calibrated in bar and psi
- Ideal for use in many applications, specifically for high cycle and harsh environments
- Gauge snubbers or needle valves recommended to shut off gauge when not in use.



Gauge adaptor assembly

45° Angled gauge adaptor **GA45GC** improves safe working conditions.

Page: 142



Gauge Adaptor

For easy gauge installation into almost any system, Enerpac offers a complete line of gauge adaptors.

Page: 143



Snubber Valve V91

Infinitely adjustable for metering oil out of a gauge. The V91 Snubber Valve is also suitable as a shut-off valve to protect the gauge during high cycle applications.

Page: 144

◀ When lifting or pressing, always use a gauge. A gauge is your 'window' to the system. It lets you see what's going on.

Hydraulic Pressure Gauges



CAUTION! When lifting or pressing, always use a gauge

Do not override factory setting of relief valves. Always use a gauge to check system pressure. A gauge is your 'window' to the system. It lets you see what's going on. See our Safety Instructions.

Page: 406

G H Series



Pressure Range:

0 - 1000 bar

Face Diameter:

63 - 100 mm

Accuracy, % of full scale:

± 1,0 - 1,5%

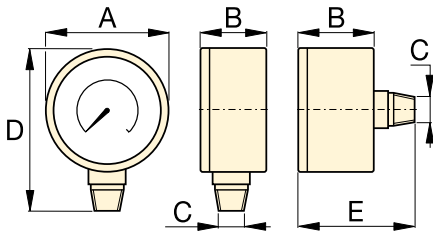

Size (mm)	Connection	Dimensions (mm)				
		A	B	C	D	E
63	Lower Mount	63	37	¼" NPTF	84	-
63	Center Rear	63	37	¼" NPTF	-	63
100	Lower Mount	100	29	¼" NPTF	121	-
100	Lower Mount	100	49	½" NPTF	136	-

Note: dimensions for reference only.



Maximum Indicator Pointer

Indicator retains peak readings of pressure or force generated by the system.

Can easily be installed on GP and H-Series ø 100 mm gauges. Order model nr: **BSA881**.

▼ SELECTION CHART

Gauge Series	Pressure Range		Model Number				Major Graduation		Minor Graduation		Major Graduation		Minor Graduation	
			ø 63 ¼" NPTF Lower Mount	ø 63 ¼" NPTF Center Rear	ø 100 ¼" NPTF Lower Mount	ø 100 ½" NPTF Lower Mount	bar		psi		bar		psi	
	(bar)	(psi)	Accuracy: ± 1,5 %		Accuracy: ± 1,0 %		ø 63	ø 100	ø 63	ø 100	ø 63	ø 100	ø 63	ø 100
	G-Series	0-7	0-100	G2509L	-	-	-	1	-	0,01	-	10	-	2
0-11		0-160	G2510L	-	-	-	1	-	0,02	-	10	-	2	-
0-14		0-200	G2511L	-	-	-	1	-	0,02	-	50	-	5	-
0-20		0-300	G2512L	-	-	-	5	-	0,50	-	50	-	5	-
0-40		0-600	G2513L	-	-	-	10	-	1	-	100	-	10	-
0-70		0-1.000	G2514L	G2531R	-	-	10	-	1	-	100	-	20	-
0-140		0-2.000	G2515L	-	-	-	10	-	5	-	500	-	50	-
0-200		0-3.000	G2516L	-	-	-	50	-	5	-	500	-	50	-
0-400		0-6.000	G2517L	G2534R	-	-	100	-	10	-	1000	-	100	-
0-700		0-10.000	G2535L	G2537R	G4088L	G4039L	100	100	10	10	2000	1000	200	100
0-1000	0-15.000	G2536L	G2538R	G4089L	G4040L	100	100	20	20	3000	3000	200	200	
H-Series	0-700	0-10.000	-	-	H4049L	H4071L	-	100	-	10	-	1000	-	100

▼ Gauge shown: **T6003L**



- **Dual scale reading calibrated in bar and psi**
- **All gauges have spring-loaded backs with rubber blow-out plugs to protect case assembly in case of over-pressurization**
- **Integral maximum indicator pointer standard included**
- **2800 and 3500 bar models include flange mounting**
- **½" NPTF versions are made of high strength alloy steel**
- **0.25" cone models are made of 316 stainless steel, with 403 stainless steel on 2800 and 3500 bar models.**

▼ An Enerpac P2282 hand pump equipped with a T6011L test system gauge is used for proof pressure testing of hydraulic valves.



T Series

Pressure Range:
0 - 3500 bar

Face Diameter:
162 - 192 mm

Accuracy, % of full scale:
± 0,5 - 1,5%



Cone Mount Gauge Adaptor

Contains fittings to connect ¼" cone fitting gauge to ⅜" cone system. Kit includes 43-301 tee, 43-704 gauge adaptor and 45-116 tubing. Order model number: **83-011**.

Page: **85**



Cone Mount Gauge Connector

For connecting gauges with 0.25" cone fitting directly to model number **11-100** or **11-400** pump (page 84). May be used with other

0.25" cone systems
Order model number: **43-704**

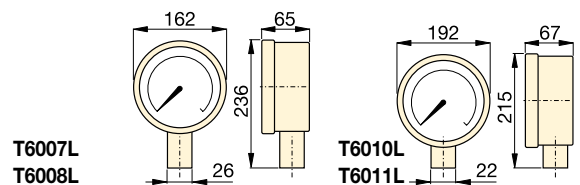
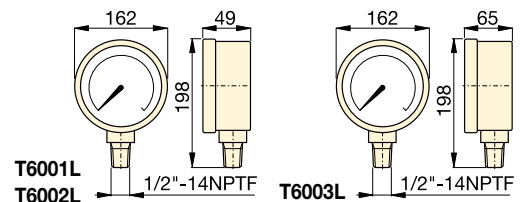

Pressure Range (bar)	Pressure Range (psi)	Model Number		Number Intervals (bar)	Graduation Intervals (bar)	Number Intervals (psi)	Graduation Intervals (psi)
		Alloy Steel ½" NPTF	Stainless Steel 0,25 cone				
0-70 ¹⁾	0-1000	T6001L	–	10	1	100	10
0-350 ¹⁾	0-5000	T6002L	–	50	5	500	50
0-700 ¹⁾	0-10.000	T6003L	T6007L	100	10	1.000	100
0-1400 ¹⁾	0-20.000	–	T6008L	200	20	1.000	100
0-2800 ²⁾	0-40.000	–	T6010L	500	20	5.000	200
0-3500 ²⁾	0-50.000	–	T6011L	500	50	5.000	200

¹⁾ Accuracy ± 0,5%

²⁾ Accuracy ± 1,5%

Digital Hydraulic Pressure Gauge

▼ Gauge shown: DGR2



- Rated for system pressure up to 1380 bar
- Displays in bar, psi, MPa and kg/cm²
- Zero reset - ensures that gauge reads actual pressure
- IP65 protection, UL listed, CE and RoHS compliant
- Batteries included, condition indicator on read-out
- Shut-off selectable – menu driven
- Back-lit readout allows easy reading in less than ideal lighting
- Protective cover included.

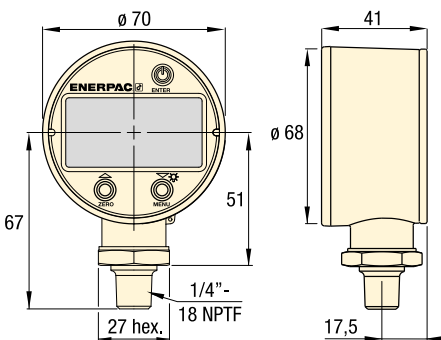

High Pressure Rating (bar)		High Pressure Rating (MPa)		Model Number	High Pressure Rating (psi)		High Pressure Rating (kg/cm ²)	
Range	Resolution	Range	Resolution		Range	Resolution	Range	Resolution
0-1380	0,1	0-140	0,01	DGR2	0-20.000	1	0-1400	0,1

Weight: 0,23 kg.

DGR Series

Pressure Range:

0 - 1380 bar

Voltage:

3 Volt (battery)

Accuracy, % of full scale:

± 0,25%



Gauge Adaptor

For easy gauge installation into almost any system, Enerpac offers a complete line of gauge adaptors. Maximum operating pressure 700 bar.

Page: 143

▼ Greater accuracy and easier to read: enhance your ability to monitor and control hydraulic system pressure up to 1380 bar.



▼ Shown: GA45GC



- 45° angled gauge improves visibility
- Slim and narrow design
- Easy to fit in a broad range of systems
- Maximize controlled load movement
- Glycerin dampened gauge with dual scale
- Enerpac High-Flow female coupler CR400.

GA45GC Series

Connection 1:
3/8" NPTF male

Connection 2:
CR400 coupler

Maximum Operating Pressure:
700 bar



4-Way Manifold assembly complete with gauges

Offering ease of portability and convenience with an ergonomic robust design, ready for use.

CR400 female couplers on all ports allow the manifold to be quickly connected to up to 4 cylinders. Glycerine filled, 700 bar gauges and shut-off valves allow operators to work safely. All protected by the robust protection frame.

Manifold Type (Used for cylinders)	Model Number
4x Single-acting	AMGC41
4x Double-acting	AMGC42

Page: **132**



Power Box

Portable tool box with hand pump, GA45GC gauge adaptor assembly, hose and RC, RSM, RCS-cylinder, WR5 wedgie or LW16 lifting wedge.

Page: **65**

▼ The Gauge Adaptor Assembly is the window to your system; allows easy reading of the pressure for safe operation.

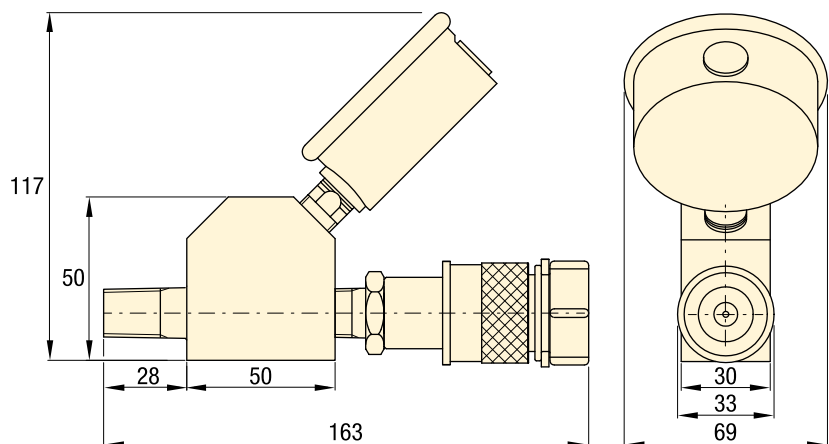

Model Number	Gauge Port (1/4" NPTF)	Male End (NPTF)	Female End (3/8" NPTF)	Gauge Range	
				(bar)	(psi)
GA45GC	G2535L	3/8" -18	CR400	0 - 700	0 - 10.000

▼ Shown from left to right: GA3, V91, GA1, GA2, GA4, NV251, GA918



GA, NV, V Series

Maximum Operating Pressure:
700 bar

▼ A gauge is easily installed into your hydraulic system using a gauge adaptor.



Gauge Adaptors (GA-Series)

- For easy mounting of a pressure gauge onto your system
- Male end screws into pump or cylinder port, female end accepts hose or coupler, 3rd port is for gauge connection
- GA918 provides for swivel connection.

Model Number	Gauge Port (NPTF)	Male End (NPTF)	Female End (NPTF)	Dimensions (mm)					
				A	B	C	D	E	F
GA1	1/2"	3/8"	3/8"	71	31	1/2" NPTF	3/8" NPTF	3/8" NPTF	32
GA2	1/2"	3/8"		155	35	1/2" NPTF	3/8" NPTF	3/8" NPTF	32
GA3	1/4"	3/8"		133	35	1/4" NPTF	3/8" NPTF	3/8" NPTF	32
GA4	1/2"	1/4"		111	35	1/2" NPTF	1/4" NPTF	3/8" NPTF	32

GA1

GA2, GA3, GA4

Swivel Adaptor (GA918)

- Simplifies gauge installation and reading.

Model Number	Dimensions (mm)						
	A	B	C	D	E	S	S1
GA918	117	43	1/2" NPTF	28,5	1/2" NPTF	29	38

GA918

Needle Valves (V- and NV-Series)

- Both NV251 and V91 provide positive shut-off
- 316 stainless steel stem, 24 threads/in (NV251).

Model Number	Orifice (mm)	Thread Size	Dimensions (mm)						
			A	B	C	D	E	F	H
NV251	4,3	1/4" NPTF	57	29	1/4" NPTF	57	46	19	19
V91	4,8	1/2" NPTF	89	32	1/2" NPTF	64	32	37	37

NV251

V91

▼ From left to right: V152, V66, V82, V161, V42, V17



Your Hydraulic Control Solution



Valve Applications

To see these valves used in typical hydraulic circuits, please see our 'Yellow Pages'.

Page: **410**

▼ The V152 pressure relief valve limits the pressure or force developed in the hydraulic system.



- All valves are rated for 700 bar operating pressure
- All valves feature NPTF porting to insure against leakage at rated pressure
- All valves are painted, coated, or plated for corrosion resistance
- Viton® seals (in V66NV and V152NV) for high temperature applications, nickel-plated for maximum corrosion resistance.

Valve dimensions in mm

<p>V82</p>	<p>V182</p>	<p>V8F</p>	<p>V91</p>
<p>V10</p>	<p>V17</p>	<p>V42</p>	
<p>V66, V66NV</p>	<p>V66F</p>	<p>V152, V152NV</p>	<p>V161</p>

Pressure and Flow Control Valves



Control Manifolds

For two or four port manifolds with integral flow control valves, see the manifold page of the System Components section.

Page: 132



Fittings











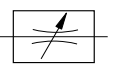

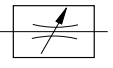

For additional fittings see the fitting page of the System Components section in this catalogue.

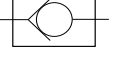
Page: 133

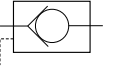
V Series

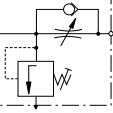

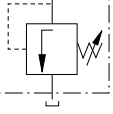
Maximum Operating Pressure:
700 bar

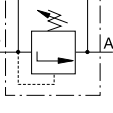
Valve Type and Model Number	Description	Hydraulic Symbol
Needle Valve V82 V182 V8F	 <p>V82: To control cylinder speed. Can also be used as shutoff valve for temporary load holding. 3/8" NPTF ports, nickle plated. V182: Same as V82, but with 1/4" NPTF female ports, nickle plated.</p>	<p>Also suitable for gauge snubbing (also V82). V8F: Like V82, but with very fine metering for precise flow control 0,16 - 14,7 l/min at 275 bar. Not recommended as shut-off valve.</p> 
Snubber Valve V91	 <p>V91: Infinitely adjustable for metering oil out of a gauge to prevent snapping of gauge pointer when load or pressure is suddenly released.</p>	<p>Also suitable as shutoff valve to protect the gauge during high cycling applications. 1/2" NPTF male and female threads for use with GA1, GA2 or GA4 gauge adaptors.</p> 
Auto Damper® Valve V10	 <p>V10: To be used when gauge pressure must be monitored during high cycle applications. Creates a flow resistance when load is released suddenly.</p>	<p>No adjustments are necessary. 1/2" NPTF male and female threads for use with GA1, GA2 or GA4 gauge adaptors.</p> 
Check Valve V17	 <p>V17: Ruggedly built to resist shock and operate with low pressure drop. Closes smoothly without pounding. 3/8" NPTF female port.</p>	
Pilot Operated Check Valve V42	 <p>V42: Can be mounted at the cylinder to hold the load in case of system pressure loss. Normally used with doubleacting cylinders where pilot port receives pressure from a Tee-fitting in the cylinder retract line.</p>	<p>3/8" NPTF female ports. Pilot presure ratio 14% (6,5:1).</p> 
Manually Operated Check Valve V66, V66NV * V66F	 <p>V66, V66NV: For load holding applications with single and double acting cylinders. Valves allow oil to flow back to tank when cylinder retracts.</p>	<p>V66NV with Viton seals, nickelplated. V66F: Similar to V66, but with very fine metering capability for precise flow control. V66F is not designed for load holding.</p> 
Pressure Relief Valve V152 V152NV *	 <p>V152: Limits pressure developed by the pump in hydraulic circuit, thus limiting the force imposed on other components. Valve opens whenever preset pressure is reached.</p>	<p>To increase pressure setting, turn handle clockwise. Includes:</p> <ul style="list-style-type: none"> • 0,9 m return line hose kit, • ± 3% repeatability, • 55 - 700 bar adjustment range. 
Sequence Valve V161	 <p>V161: To control oil flow to a secondary circuit. Flow is blocked until system pressure rises to the V161 setting. When this pressure level is reached, the V161 opens to allow flow to the secondary circuit.</p>	<p>A pressure differential is always maintained between the primary and secondary circuit. Mininum operating pressure: 140 bar.</p> 

* See page 64 for more information about products for use in high temperature and extreme environment applications.

Enerpac Hydraulic Presses are available in a variety of capacities and sizes. The press frames are designed for maximum strength and durability. Strong frames and powerful high-pressure hydraulics will provide years of dependable service in many applications.

Enerpac Presses are available in H-Frame, Roll-Frame, Arbor, C-Clamp and Bench models.

Available in capacities from 10 to 200 ton, each Enerpac press consists of three basic high quality components: press frame, power source and hydraulic cylinder.

These Press features increase productivity and broaden the range of applications:

Side-to-side cylinder movement

Lateral movement capability of cylinder in upper bed.



Hydra-Lift

Standard on many Enerpac IP-Series Presses, the exclusive Hydra-Lift™ offers effortless adjustment to the press daylight by use of a hydraulic lift.



Press Section Overview

Available in capacities from 10 to 200 ton, each Enerpac press consists of three basic high quality components: a press frame, a power source and a cylinder.

Press Frame

Press frames include features like workpiece side-loading and height adjustment of the upper and lower bed.

Power Source







Depending on the production requirements, Enerpac presses can be powered by manual, air-hydraulic and electric-drive power sources.

Cylinder

Depending on the application, double-acting cylinders offer increased efficiency. Check out the Selection Charts for the press best suited for your needs.

Gauge

All H-Frame, Roll-Frame and Bench Presses feature an easy to monitor pressure/force gauge for increased safety, gauge adaptor and hose(s).

Capacity ton (kN)	Press type and functions		Series	Page
10 - 200 (101 - 1995)	H-Frame Presses	IP		148 ▶
50 - 200 (498 - 1995)	Roll-Frame Presses	IPR		152 ▶
5 - 20 (45 - 178)	C-Clamp Presses	A		154 ▶
10 - 30 (101 - 295)	Arbor Presses	A		154 ▶
10 (101)	Bench Presses	VLP		154 ▶
–	Custom Hydraulic Presses			156 ▶
900 - 90.000 kg	Tension Meters Load Cells	TM LH		157 ▶



IMPORTANT!

The pressframe of the workshop presses are exclusively designed for pressing operations, not for pulling. For pulling applications please contact Enerpac.

In order to fully comply with CE regulations, some presses must be equipped with specific safety components, such as spring centered valves, two-hand control devices, guards or others.

Enerpac standard general purpose presses are supplied without guards, and have a plunger speed of less than 10 mm/second.

However, your application may require that measures should be taken to reduce the risk of injury to operators and other personnel by providing appropriate safeguarding, training and conducting a risk assessment, which eliminates or reduces danger.

Health & safety within your workplace is your responsibility, not that of Enerpac. Advice on such matters is available from your local enforcement agency. If you require any further information on Enerpac accessories that may help you conform to the Machinery Directive or European legislation contact Enerpac.

▼ IPE5060A, H-Frame Press



- Quality welded frame for maximum strength and long life
- Exclusive “Hydra-Lift” bed for effortless adjustment of the vertical daylight (10 ton models are manual)
- Roller head design is standard to allow movement and locking of the cylinder from side to side (10-ton, 25-ton and 30-ton are manual)
- All models in the Quick Selection Chart have been matched to a pump, cylinder, hose, gauge and gauge adaptor offering the complete package.



Great Possibilities Great Performance



Cylinder Mounting Block

Allows cylinder mounting into a press frame, while also allowing side to side adjustment of cylinder position.



Hydra-Lift

Allows easy and effortless daylight adjustment. Standard on most IP-Series H-Frame Presses.

Page: 151



Pressure & Force Gauges

All press models include a GF-Series gauge and gauge adaptor, matching the press capacity. GF-Series indicate the pressure (bar) and force (kN).



Hoses

All IP-Series H-Frame Presses include hose(s), offering the complete package.



V-Blocks

These V-Blocks are designed for easy fixturing of round stock and other non-uniform materials. Featuring precise fit into the press bolster.

Page: 151

◀ An Enerpac H-Frame press quickly removes the shaft from this assembly.



Safety Screen

Universal moveable safety screen to be positioned before any press.

- Aluminium safety screen with polycarbonate glass
- Versatile use and protection
- Lockable wheels for easy positioning.

Description	Model Number
Universal Safety Screen	XLPSS1



▲ Press with safety cage to ensure additional operator safety.

IP Series



Press Capacity:

10 - 200 ton

Maximum Daylight x Max. Bed Width:

1525 x 1225 mm

Maximum Operating Pressure:

700 bar



10 ton Bench Presses

For 10 ton VLP-Series Bench Presses selection see:

Page: **154**

▼ QUICK SELECTION CHART

For more technical information see next page.

Press Capacity ton (kN)	Maximum Bed Daylight (mm)	Maximum Bed Width (mm)	Power Source					Press Model Number	Cylinder			Speed * (mm/sec)	
			Type			Valve					Stroke (mm)	Rapid Advance	Pressing
			Man.	Elec.	Air	Man.	Elec.						
10 (101)	1525	456		●		●			●		254	38	3,7
	1525	456			●	●			●		254	23	2,9
	1525	456	●			●			●		254	[7,8]	[1,7]
	1525	456	●			●				●	254	[11,2]	[1,7]
	1525	456			●	●				●	254	23	2,9
25 (232)	1388	733		●		●			●		152	17	1,6
	1388	733		●			●		●		355	30,9	2,8
	1388	733			●	●			●		355	10	1,3
	1388	733	●			●			●		355	[4,9]	[0,7]
30 (295)	1388	733			●	●				●	355	42,0	0,6
	1388	733		●			●			●	355	24,3	2,2
	1388	733	●			●				●	355	[3,7]	[0,6]
50 (498)	1406	745		●			●		●		330	20,8	1,9
	1406	745	●			●			●		159	[2,3]	[0,3]
	1406	745		●			●		●		159	7,7	0,7
	1406	745			●	●				●	330	32,6	3,1
	1406	745		●			●			●	330	20,8	1,9
	1406	745	●			●				●	330	[17,7]	[0,7]
100 (933)	1096	885			●	●			●		254	17,4	1,6
	1096	885		●			●		●		254	11,1	1,0
	1096	885	●			●			●		254	[8,8]	[0,3]
	1096	885		●			●			●	330	11,1	1,0
	1096	885	●			●				●	152	[8,8]	[0,3]
150 (1386)	1323	1225		●			●			●	330	9,8	1,4
200 (1995)	1323	1225		●			●			●	330	6,8	1,0

* [...] = Millimetres per stroke of pump handle.



Hydra-Lift™

Allows easy, effortless daylight adjustment. Standard on all 25 to 200 ton H-Frame presses.

To be used with H-Frame Press Capacity	Hydra-Lift™ Model Number
25 to 100 ton	IPL100
150 and 200 ton	IPL101

IMPORTANT: Hydra-Lift™ is not designed to withstand full cylinder capacity, only to be used for bed positioning.

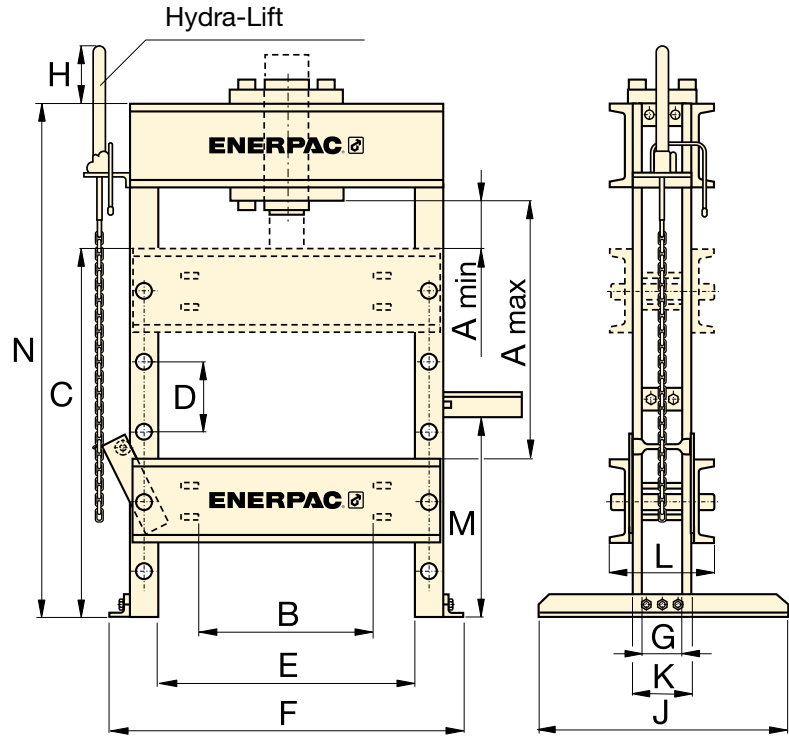

IP-Series H-Frame Presses

◀ For full features see previous page.

Press Capacity ton (kN)	Press Model Number	Pump Model Number	Page:	Cylinder Model Number	Page:	H-Frame Press Dimensions (mm)						
						A (max.)	A (min.)	B	C	D	E	F
10 (101)	IPE1215A	PUJ1200E	90	RC1010	6	1525	128	-	1599	127	456	635
	IPA1220A	XA11	114	RC1010	6	1525	128	-	1599	127	456	635
	IPH1240A	P392	76	RC1010	6	1525	128	-	1599	127	456	635
	IPH1234A	P84	78	RR1010	40	1525	128	-	1599	127	456	635
	IPA1244A	XA11VG	114	RR1010	40	1525	128	-	1599	127	456	635
25 (232)	IPE2505A	PUJ1200E	90	RC256	6	1388	180	-	1450	301	733	1028
	IPE2510A	ZE3310SE	104	RC2514	6	1388	180	-	1450	301	733	1028
	IPA2520A	XA12	114	RC2514	6	1388	180	-	1450	301	733	1028
	IPH2531A	P80	78	RC2514	6	1388	180	-	1450	301	733	1028
30 (295)	IPA3071A	PAM1042	97	RR3014	40	1388	242	-	1450	301	733	1028
	IPE3060A	ZE3410SE	104	RR3014	40	1388	242	-	1450	301	733	1028
	IPH3080A	P84	78	RR3014	40	1388	242	-	1450	301	733	1028
50 (498)	IPE5010A	ZE4310SE	104	RC5013	6	1406	195	530	1371	263	745	1085
	IPH5031A	P80	78	RC506	6	1406	195	530	1371	263	745	1085
	IPE5005A	PUJ1200E	90	RC506	6	1406	195	530	1371	263	745	1085
	IPA5073A	ZA4410MX	116	RR5013	6	1406	195	530	1371	263	745	1085
	IPE5060A	ZE4410SE	104	RR5013	40	1406	195	530	1371	263	745	1085
	IPH5080A	P464	78	RR5013	40	1406	195	530	1371	263	745	1085
100 (933)	IPA10023A	ZA4210MX	116	RC10010	6	1096	145	600	1296	300	885	1289
	IPE10010A	ZE4310SE	104	RC10010	6	1096	145	600	1296	300	885	1289
	IPH10030A	P462	78	RC10010	6	1096	145	600	1296	300	885	1289
	IPE10060A	ZE4410SE	104	RR10013	40	1096	145	600	1296	300	885	1289
	IPH10080A	P464	78	RR1006	40	1096	145	600	1296	300	885	1289
150 (1386)	IPE15065A	ZE5420SW	104	RR15013	40	1323	307	975	1485	254	1225	1725
200 (1995)	IPE20065A	ZE5420SW	104	RR20013	40	1323	307	975	1485	254	1225	1725

H-Frame Presses



Optional V-Blocks

To facilitate positioning of pipes and bars, or placed upside-down, to serve as a convenient worktable.

Featuring precise fit into the press bolster. Each model number includes two V-blocks.

To be used with press model	V-Blocks Model Nr.
10 ton H-frame	A136
25 & 30 ton H-frame	A130
50 ton IP H-frame	A150
100 ton H-frame	A175
150 & 200 ton H-frame	A200R



IMPORTANT!

The pressframe of the workshop presses are exclusively designed for pressing operations, not for pulling. For pulling applications please contact Enerpac.

IP Series



Press Capacity:

10 - 200 ton

Maximum Daylight x Max. Bed Width:

1525 x 1225 mm

Maximum Operating Pressure:

700 bar

H-Frame Press Dimensions (mm)								Press Model Number
G	H	J	K	L	M	N	(kg)	
-	-	755	100	210	818	1829	98	IPE1215A
-	-	755	100	210	818	1829	81	IPA1220A
-	-	755	100	210	818	1829	81	IPH1240A
-	-	755	100	210	818	1829	98	IPH1234A
-	-	755	100	210	818	1829	89	IPA1244A
101	336	762	133	309	855	1930	264	IPE2505A
101	336	762	133	309	855	1930	298	IPE2510A
101	336	762	133	309	855	1930	256	IPA2520A
101	336	762	133	309	855	1930	263	IPH2531A
101	336	762	133	309	855	1930	301	IPA3071A
101	336	762	133	309	855	1930	339	IPE3060A
101	336	762	133	309	855	1930	273	IPH3080A
127	222	914	212	394	790	1930	523	IPE5010A
127	222	914	212	394	790	1930	430	IPH5031A
127	222	914	212	394	790	1930	440	IPE5005A
127	222	914	212	394	790	1930	541	IPA5073A
127	222	914	212	394	790	1930	533	IPE5060A
127	222	914	212	394	790	1930	489	IPH5080A
160	222	950	268	468	663	1930	787	IPA10023A
160	222	950	268	468	663	1930	809	IPE10010A
160	222	950	268	468	663	1930	764	IPH10030A
160	222	950	268	468	663	1930	823	IPE10060A
160	222	950	268	468	663	1930	752	IPH10080A
257	175	1148	382	582	1094	2273	1900	IPE15065A
257	175	1148	382	582	1094	2273	1951	IPE20065A



Pressure & Force Gauges

All press models include a GF-Series gauge and gauge adaptor, matching the press capacity. GF-Series indicate the pressure (bar) and force (kN).

Press Capacity ton (kN)	Gauge Model Number	Adaptor Model Number
10 (101)	GF10B	GA2
25 (232)	GF20B	GA2
30 (295)	GF835B	GA3
50 (498)	GF50B	GA2
100 (933)	GF871B	GA3
150 (1386)	GF200B	GA3
200 (1995)	GF200B	GA3

For more information on gauges, please refer to the System Components section.

Page: 136



Spring Centred Valves

To convert standard VM-Series manual valves use the spring centered valves kits.

For valve model	Model Number
VM33, VM43	VMC3343K
VM33L, VM43L	VMC3343KL

▼ Shown: IPR5075A



- Quality welded frame for maximum strength and long life
- Frame rolls easily on 4 steel roller bearings
- Exclusive 'Hydra-Lift' bolster for effortless adjustment of the vertical daylight
- Standard roller head design allows lateral movement and locking of the cylinder up to 300 mm left or right of centre
- All models in the quick selection chart have been matched to an electric pump, double-acting cylinder, hose and gauge, offering the complete package
- Roll-Frame design features a stationary bed with the ability to support heavy loads
- Hydraulic clamp cylinder locks roll-frame into position.

Expert Designed Versatility



Hydra-Lift™

Allows easy, effortless daylight adjustment. Standard on all IPR-Series Roll-Frame Presses.

To be used with IPR-Roll-Frame Press Capacity	Hydra-Lift™ Model Number
50 & 100 ton	IPLR100
200 ton	IPLR101

IMPORTANT: Hydra-Lift™ is not designed to withstand full cylinder capacity, only to be used for bed positioning.



Cylinder adjustment

Cylinder adjustment allows horizontal side to side cylinder positioning.



Optional V-Blocks

To facilitate positioning of pipes and bars, or placed upside-down, to serve as a convenient worktable. Featuring precise fit into the

press bolster. Each model number includes two V-blocks.

To be used with press model	V-Blocks Model Number
200 ton IPR-Press	A200R

▼ SELECTION CHART

Press Capacity ton (kN)	Vertical Daylight A (mm)		Maximum Bed Width E (mm)	Electric Pump		Press Model Number	Double-Acting Cylinder			Speed (mm/sec)	
	min.	max.		Model Number	Page		Stroke (mm)	Model Number	Page	Rapid Advance	Pressing
50 (498)	131	922	813	ZE4410SE	104	IPR5075A	334	RR5013	40	20,8	1,9
100 (933)	320	1208	886	ZE5410SW	104	IPR10075A	333	RR10013	40	14,5	2,1
200 (1995)	376	1138	1222	ZE5420SW	104	IPR20075A	330	RR20013	40	7,2	1,0

Roll-Frame Presses



▲ For offshore application high capacity spring loaded cylinders need to be assembled and tested. A special 100 ton roll frame press, with long stroke cylinder has been constructed. All movements are operated and monitored through a PLC controlled pendant.



IMPORTANT!

The frameworks of the presses are exclusively designed for pressing operations, not for pulling. For pulling applications please contact Enerpac.

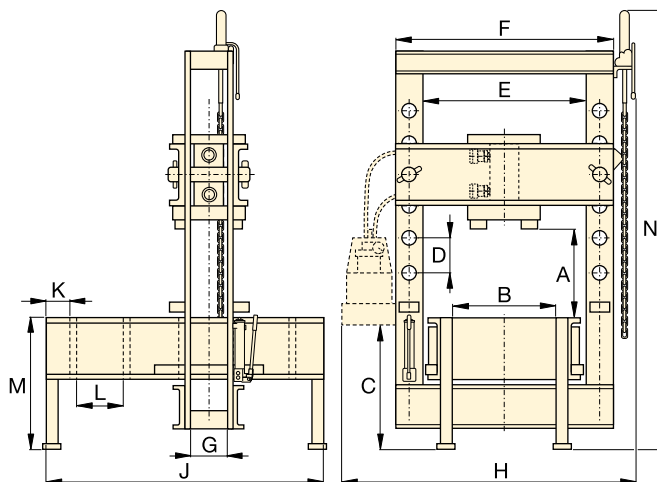

IPR Series



Capacity:

50 - 200 ton

Maximum Daylight x Width:

1208 x 1222 mm

Maximum Operating Pressure:

700 bar



Pressure & Force Gauges

All press models include a GF-Series gauge and gauge adaptor, matching the press capacity. GF-Series indicate the pressure (bar) and force (kN).

Press Capacity	Gauge Model Number	Adaptor Model Number
ton		
50	GF50B	GA2
100	GF871B	GA3
200	GF200B	GA3

For more information on gauges, please refer to the System Components section.

Page: 136



Spring Centred Valves

Manual valves on electric and air pumps of Enerpac presses are Spring Centred Valves. The handle will automatically move into the neutral valve position when released.

Page: 123

Roll-Frame Press Dimensions (mm)														Press Model Number
A (min.-max.)	B	C	D	E	F	G	H	J	K	L	M	N	(kg)	
131 - 922	686	971	264	813	1006	102	1557	1626	216	270	800	2629	917	IPR5075A
320 - 1208	706	965	222	886	1140	143	1588	1677	220	270	800	2778	1767	IPR10075A
376 - 1138	1010	933	254	1222	1622	257	2197	1631	380	381	889	3115	4186	IPR20075A

▼ Shown from left to right: A220, A330, A310



C-Clamp Presses

- 5, 10 and 20 ton capacity
- Operational in all positions.

Arbor Presses

- 10 and 30 ton capacity
- Foot mounting holes for horizontal or vertical positioning
- Machined working surfaces for easier fixturing
- Slotted back to simplify loading and unloading of longer parts.

VLP-Series Bench Presses

- 10 ton press with hand pump or air pump, cylinder, hose, gauge and gauge adaptor.



Shown: VLP106P142 ►

The Standard Workshop Tools



Push Pin A183

For applications requiring precision pressing, such as shaft removal and insertion. This attachment fits 10 ton cylinders and requires the use of a threaded adaptor saddle (A13).

Page: 182



Smooth Saddle A185

For pressing applications of delicate parts, such as aluminium castings, this saddle (see item 11 on page 183) decreases surface marks during the pressing application. Requires 10 ton cylinder and threaded adaptor saddle (A13).



Optional V-Blocks

To facilitate positioning of pipes and bars, or placed upside-down, to serve as a convenient worktable. Each modelnr includes 2x V-block.

To be used with press model	V-Blocks Modelnr.
10 ton VLP-Bench Presses	VB10



IMPORTANT! For high-cycle production applications, the C-Clamp and Arbor presses should be limited to 50% of their capacity.

▼ A310 Arbor Press



▼ SELECTION CHART

Press Type	Press Capacity ton (kN)	Maximum Vertical Daylight (mm)	Maximum Bed Width (mm)	Press Model Number	Recommended cylinder * must be ordered separately ** Must be limited to 20 ton.	Page:
C-Clamp	5 (45)	165	51	A205	5 ton RC-cylinder *	6
	10 (101)	228	57	A210	10 ton RC-cylinder *	6
	20 (178)	305	69	A220	25 ton RC-cylinder **	6
Arbor	10 (101)	230	135	A310	10 ton RC-cylinder *	6
	30 (295)	254	178	A330	RC308 *	6

Press Capacity ton (kN)	Maximum Daylight (mm)		Bench Press Model Number	Power Source included			Cylinder included			
	Vertical	Horizontal		Pump Type Man. Air	Pump Model Nr.	Page:	Stroke (mm)	Cylinder Model Nr.	Page:	
10 (101)	430	435	VLP106P142	●		P142	76	156	RC106	6
	430	435	VLP106PAT1		●	PATG1102N	112	156	RC106	6

C-Clamps, Arbor and Bench Presses



▲ RC308 cylinder mounted in A330 Arbor Press powered by a PATG-Turbo Air pump for controlled pressing of bearings for sprockets of weaving machines. The V152 Pressure Relief Valve controls the pressing force.

A VLP Series



Capacity:
5 - 30 ton

Maximum Daylight x Width:
430 x 435 mm

Maximum Operating Pressure:
700 bar



Pumps and Cylinders

Pump, cylinder, hose, gauge and gauge adaptor for C-Clamps and Arbor Presses must be ordered separately.

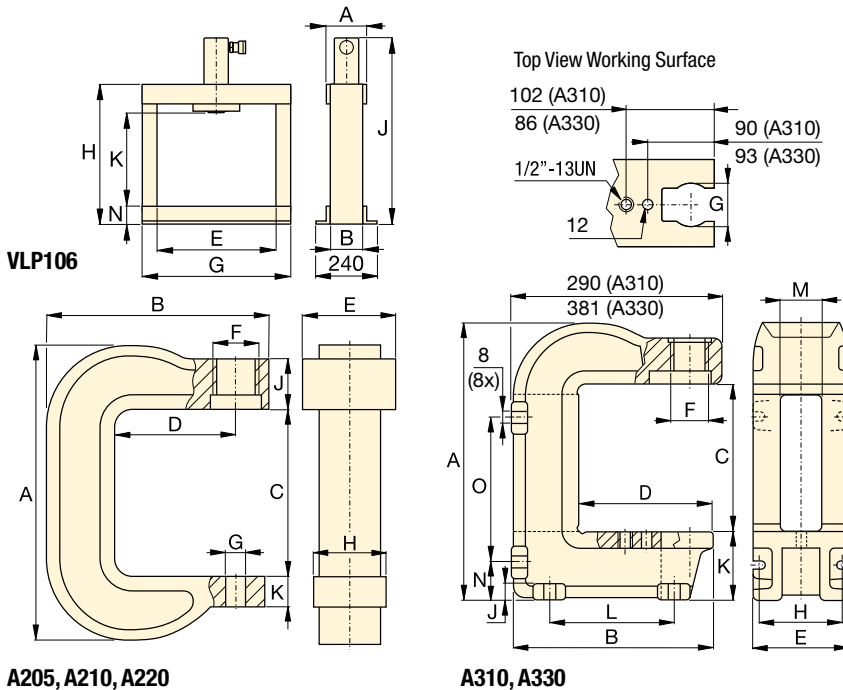

▲ VB10 V-Blocks are used in this VLP106P142 bench press to bend flat steel bar. The hydraulic pressure can be checked with the gauge.

Press Dimensions (mm)															Press Model Number
A	B	C	D	E	F	G	H	J	K	L	M	N	O	(kg)	
291	203	165	95	73	1½" -16 UNS	26	51	66	25	-	-	-	-	7	A205
406	283	228	152	83	2¼" -14 UNS	26	76	64	41	-	-	-	-	17	A210
540	346	305	152	121	3⅝" -12 UNS	26	95	70	44	-	-	-	-	38	A220
414	281	230	184	151	2¼" -14 UNS	63	122	19	95	175	65	54	219	28	A310
563	356	254	188	178	3⅝" -12 UNS	63	140	28	168	203	67	99	276	100	A330

Speed (mm/s) **		Dimensions (mm)										Bench Press Model Number
Rapid Advance	Pressing	A	B	E	G	H	J	K	N	(kg)		
{2,5} **	{0,6} **	110	80	435	542	620	748	430	80	49	VLP106P142	
10,0	1,8	110	80	435	542	620	748	430	80	54	VLP106PAT1	

** {...} = advance speed in mm per handpump stroke.

With decades of experience and in-house capabilities look to Enerpac to help find solutions to your customization needs.

Next to our large range of standard workshop presses, Enerpac offers the possibility of customization. Because many customers have specific requirements, we offer turn-key project management, including design, engineering and manufacturing. As the market leader, we listen to our customers and with our world

wide experience we offer the best solutions, especially when safety is not negotiable. Whether a longer stroke, wider frame or complete new design is required, our custom product group has many years of experience in multiple industries to deliver a solution that meets or exceeds expectations.

Overview Custom Presses



▲ Enerpac's hydraulic presses can be configured to fulfill a broad range of applications. Each press is designed and manufactured according to customer specifications and in cooperation with our engineering team.



◀ Fully Automated PLC-Controlled 1800-Ton, High-Accuracy Press. The pressing and heating cycle, during the production of magnetic acceleration coils, required high force and high- accuracy to ensure absolute quality

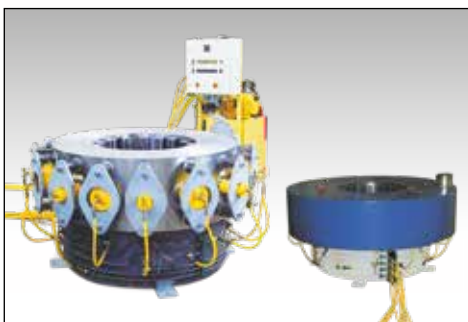

◀ 600 Ton High-Accuracy Collar Press. For the production of accelerator coils, sheet metal needs to be formed into a specific shape and size.



◀ 50 ton Workshop Press for maintenance jobs.

CUSTOMIZABLE FEATURES:

- Capacity
- Cylinder Stroke
- Pump Type
- Controls
- Guarding
- Daylight Dimensions

CONFIGURATIONS:

- Vertical and horizontal press
- Cylinders mounted in upper and lower bolsters
- Height built to customer specifications
- Daylight (vertical and horizontal) built to customer specifications

Tension Meter and Load Cells

▼ Shown: LH102 and TM5 (in middle)



TM LH Series



Capacity:

900 - 90.000 kg

Accuracy, % of full scale:

± 2%



TM and LH models are 100% tested to verify accuracy within a ± 2% range.

If your application requires a calibrated tool, it must be submitted for certification testing. Certification is NOT available from Enerpac.

Tension Meter TM5

- Accuracy ± 2% of full scale
- Zinc and bronze plated to resist corrosion
- Dual-range readout in kilograms and pounds
- Maximum indicating pointer reading for pre-selected forces or to maintain force readings
- Cushioned metal case provides safe storage and transport.

Load Cells LH-Series

- Accuracy ± 2% of full scale
- Swivel loading pad reduces eccentric loading for improved accuracy
- Maximum indicating pointer reading pre-selected forces or to maintain maximum force readings
- Dual-range readout in kilograms and pounds.

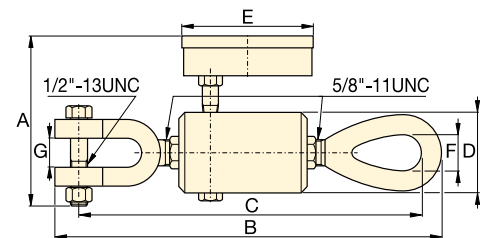

TM5

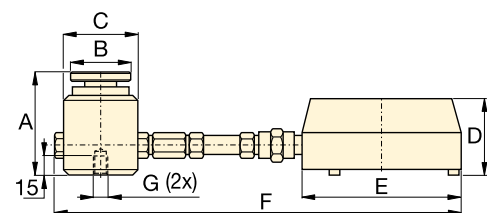

LH-Series

▼ SELECTION CHART

Type	Gauge Capacity		Model Number	Minimum Reading		Gauge Scale Increments		Dimensions (mm)						
	(kg)	(lbs)		(kg)	(lbs)	(kg)	(lbs)	A	B	C	D	E	F	G*
Direct Mounted	4.500	10.000	TM5	500	1.000	100	100	120	247	236	50	93	22	19
Direct Mounted Load Cell	900	2.000	LH10	100	200	20	20	77	44	57	60	101	215	¼" - 20, 44,5 BC
	4.500	10.000	LH50	500	1.000	100	100	77	44	57	60	101	215	¼" - 20, 44,5 BC
Remote Mounted with 0,6 m Hose	900	2.000	LH102	100	200	20	20	77	44	57	60	147	846	¼" - 20, 44,5 BC
	4.500	10.000	LH502	500	1.000	100	100	77	44	57	60	147	846	¼" - 20, 44,5 BC
	9.000	20.000	LH1002	1.000	2.000	200	200	77	44	57	60	147	846	¼" - 20, 44,5 BC
Remote Mounted with 1,8 m Hose	21.000	50.000	LH2506	3.000	5.000	500	500	101	69	85	60	147	2094	¾" - 24, 63 BC
	45.000	100.000	LH5006	5.000	5.000	1.000	1.000	132	101	127	60	147	2135	¾" - 24, 89 BC
	90.000	200.000	LH10006	10.000	10.000	1.000	2.500	158	127	158	60	147	2166	¾" - 24, 102 BC

* BC = Bolt Circle

Enerpac offers a complete line of pullers with the widest range of sizes, capacities and styles. Whether your application requires mechanical, hydraulic or the patented Lock-Grip system, Enerpac can satisfy your requirements.

Made of high strength steel alloys, you can depend on Enerpac pullers to provide years of trouble-free operation, even in the harshest environments.



Hydraulic Pullers (BHP-Series)

These hydraulic pullers eliminate time-consuming and unsafe hammering, heating or prying. Damage to parts is minimized through the use of controlled hydraulic power.



Lock-Grip Pullers (LG-Series)

The puller's self-centering closing system allows all jaws to move simultaneously, making it easy for a single operator to mount the puller and to perform the application.

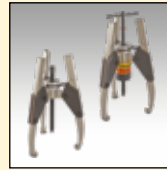

Sync-Grip Pullers (SG-Series)

Sync-Grip mechanism synchronizes movement of all jaws for simultaneous engagement and makes positioning the puller simple and helps prevent misalignment.



CAUTION! Not all puller components and configurations are rated at the set capacity. Please contact Enerpac for details.



IMPORTANT! Always wear Safety Goggles and Gloves while using pullers.



Puller Section Overview

When selecting a puller it is important to consider 3 basic specifications:

1. The Capacity:

is the amount of force the puller is capable of producing.

Typically, the capacity required for a job can be determined by using the shaft diameter of the part being pulled.

For manual pullers, the center bolt diameter of the puller should be at least half the diameter of the shaft being pulled from.

For hydraulic pullers, the capacity in tons should be 0,28 to 0,4 times the shaft diameter in mm. Use the following chart:











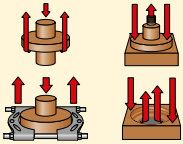

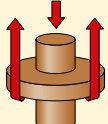

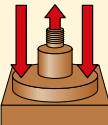

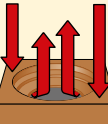

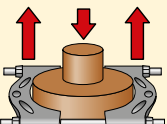

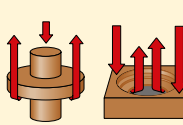

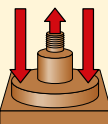

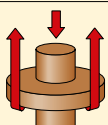
Shaft Diameter	Puller Capacity
0 - 25 mm	13 ton
25 - 50 mm	22 ton
50 - 89 mm	33 ton
89 - 140 mm	45 ton

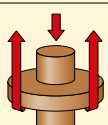
2. The Reach:

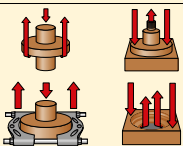
is the distance between the bottom of the base and the jaw flats. The puller's reach must equal or exceed the same distance of the part being pulled.

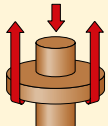
3. The Spread:

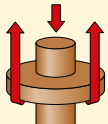
is the distance between the jaws. The puller's spread needs to be greater than the width of the part being pulled.

Puller Function	Capacity ton	Puller Type	Series	Page
	13-45	Master Puller Sets Max. Reach: 252 - 700 mm Max. Spread: 247 - 1100 mm	BHP	 160 ▶
	13-45	Grip Puller Sets Max. Reach: 252 - 700 mm Max. Spread: 249 - 1100 mm	BHP	 161 ▶
	6-22	Cross Bearing Puller Sets Max. Reach: 357 - 864 mm Max. Spread: 260 - 580 mm	BHP	 162 ▶
	6-22	Bearing Cup Pullers Max. Reach: 115 - 150 mm Max. Spread: 145 - 240 mm	BHP	 164 ▶
	6-22	Bearing Separators Max. Width: 110 - 260 mm Max. Spread: 110 - 250 mm	BHP	 164 ▶
	-	Internal/External Mech. Puller Max. Internal Reach: 45 - 79 mm Max. Internal Spread: 60 - 100 mm Max. External Reach: 55 mm Max. External Spread: 15 - 75 mm	IPM	 165 ▶
	3-40	Mechanical Lock-Grip Pullers Max. Reach: 102 - 335 mm Max. Spread: 132 - 635 mm	LGM	 166 ▶
	10-64	Hydraulic Lock-Grip Pullers and Sets Max. Reach: 215 - 408 mm Max. Spread: 300 - 660 mm	LGH LGHS	 168 ▶
	1-20	Mechanical Sync-Grip Pullers Max. Reach: 105 - 600 mm Max. Spread: 110 - 680 mm	SGM	 172 ▶ 174 ▶
	13-45	Hydraulic Sync-Grip Pullers and Master Puller Sets Max. Reach: 320 - 700 mm Max. Spread: 350 - 980 mm	SGH MPS	 172 ▶ 175 ▶
	13-45	Hydraulic Sync-Grip Pullers and Sets Max. Reach: 320 - 700 mm Max. Spread: 350 - 980 mm	SGH GPS	 176 ▶
	100	Hydraulic Sync-Grip Pullers and Sets Max. Reach: 1000 mm Max. Spread: 1600 mm	SGH GPS	 177 ▶

▼ Shown: Master Puller Set BHP3751G



Multi Purpose Puller Set



WARNING

Do not exceed 50% of the rated puller capacity when using two jaw configurations, a double crosshead (2 grip arms) or when using puller legs in combination with bearing puller attachments.



IMPORTANT!

Always wear Safety Goggles and Gloves while using pullers.

- Supplied with a full hydraulic set including pump, hose, cylinder, gauge, gauge adaptor and wooden case
- High quality, forged steel components provide superior reliability and service
- Sets include speed crank and adjusting screw for fast contact to work before hydraulics are applied
- All Master Puller Sets include a Grip Puller, a Cross Bearing Puller, a Bearing Cup Puller and a Bearing Separator, which can be ordered separately, see items nr. 10, 20, 30 and 40.



▲ Maintenance engineers throughout the industry greatly appreciate the Enerpac Master Puller sets.

▼ SELECTION CHART

Master Puller Set Capacity *	13 ton	22 ton	33 ton	45 ton **	Page:
Model Number ►	BHP1752 ¹⁾	BHP2751G	BHP3751G	BHP5751G	
Included Hydraulics Set Weight ►	37 kg	90 kg	172 kg	298 kg	
• Hand Pump	P142	P392	P392	P80	76-79 ►
• Cylinder	RWH121900	RCH202	RCH302	RCH603	34 ►
• Saddle	–	HP2015	HP3015	HP5016	35 ►
• Hose	HC7206C	HC7206C	HC7206C	HC7206C	128 ►
• Gauge + Adaptor	GA45GC	GA45GC	GA45GC	GA45GC	142 ►
Included Pullers					
10 Grip Puller	BHP1762	BHP252	BHP352	BHP552	161 ►
20 Cross Bearing Puller	BHP1772	BHP262	BHP362	BHP562	162-163 ►
30 Bearing Cup Puller	BHP180	BHP280	BHP380	BHP580	164 ►
40 Bearing Separator	BHP181	BHP282	BHP382	BHP582	164 ►
• Case	CM6	CW350	CW350	CW750	

* See warning on this page.

** Puller capacity at 540 bar; maximum cylinder capacity at 700 bar is 60 ton.

¹⁾ Includes Adaptor FZ1055.

▼ Shown: Grip Puller Set BHP351G



- Precise hydraulic control allows fast, efficient and safe pulling
- High quality, forged steel components provide superior reliability and service
- Available with and without full hydraulic set.

BHP Series



Capacity:

13, 22, 33 and 45 ton

Reach:

252 - 700 mm

Spread:

249 - 1100 mm

Maximum Operating Pressure:

700 bar

Ordering Example

Model Number BHP251G:

includes Grip Puller BHP252 and a full hydraulic set. (Hand pump, cylinder, saddle, hose, gauge and gauge adaptor).

Model Number BHP252:

includes Grip Puller mechanical parts only, for use with your existing hydraulics.

▼ SELECTION CHART

Grip Puller Set Capacity **		13 ton	22 ton	33 ton	45 ton ***
Model Number ►		BHP152 ¹⁾	BHP251G	BHP351G	BHP551G
Included Hydraulics		Set Weight ►			
		22 kg	56 kg	91 kg	160 kg
• Hand Pump		P142	P392	P392	P80
• Cylinder		RWH121900	RCH202	RCH302	RCH603
• Saddle		-	HP2015	HP3015	HP5016
• Hose		HC7206C	HC7206C	HC7206C	HC7206C
• Gauge + Adaptor		GA45GC	GA45GC	GA45GC	GA45GC
10 Grip Puller	Model Number ►	BHP1762 *	BHP252 *	BHP352 *	BHP552 *
Maximum Spread (mm)	2-jaw	249	400	593	899
	3-jaw	249	499	800	1100
Maximum Reach (mm)	2-jaw	252	300	387	700
	3-jaw	252	300	387	700
Jaw (mm)	Thickness	15	20	24	30
	Width	23	27	38	39
Adjusting Screw (mm)	Thread	¾" - 16 UNF	1" - 8 UNC	1¼" - 7 UNC	1½" - 5.5 UNS
	Length	400	670	790	975
• Case		CW166	CW166	CW350	CW750

¹⁾ Includes Adaptor FZ1055.

* Grip Puller order number without hydraulics.

** See warning on page 160.

*** Puller capacity at 540 bar; maximum cylinder capacity at 700 bar is 60 ton.

▼ BHP361G Hydraulic Cross Bearing Puller Set



- Precise hydraulic control allows fast, efficient and safe pulling
- High quality, forged steel components provide superior reliability and service
- Quick set-up to tackle a variety of jobs.

BHP Series

Capacity:

6, 11, 16 and 22 ton

Reach:

357 - 864 mm

Spread:

260 - 580 mm

Maximum Operating Pressure:

350 bar



CAUTION! Not all puller components and configurations are rated at the set capacity. Please contact Enerpac for details.

Cross Bearing Puller Sets

Hand Pump	XA11G Air Pump	PUD1300 Electric Pump	XC1201M Cordless Pump	
BHP162	BHP162A	BHP162EE *	BHP162CE *	
BHP261G	BHP261GA	BHP261GEE *	BHP261GCE *	
BHP361G	BHP361GA	BHP361GEE *	BHP361GCE *	
BHP561G	BHP561GA	BHP561GEE *	BHP561GCE *	

* E = 230 V pump. For 115 V change "E" suffix into "B".

▼ SELECTION CHART

Cross Bearing Puller Set Capacity		6 ton	11 ton	16 ton	22 ton
	Model Number ▶	BHP162 ¹⁾	BHP261G	BHP361G	BHP561G
Included Hydraulics	Set Weight ▶	26 kg	62 kg	121 kg	185 kg
• Hand Pump		P142	P392	P392	P80
• Cylinder		RWH121900	RCH202	RCH302	RCH603
• Saddle		–	HP2015	HP3015	HP5016
• Hose		HC7206C	HC7206C	HC7206C	HC7206C
• Gauge + Adaptor		GA45GC	GA45GC	GA45GC	GA45GC
20 Cross Bearing Puller ²⁾	Model Number ▶	BHP1772	BHP262	BHP362	BHP562
Spread (mm)	Maximum	260	345	440	580
	Minimum	115	140	180	220
Reach (mm)	Maximum	357	570	710	864
Adjusting Screw (mm)	Diameter	3/4" - 16 UNF	1" - 8 UNC	1 1/4" - 7 UNC	1 5/8" - 5.5 UNS
	Length	400	675	795	975
Leg (mm)	Length	105	239	203	609
	Length	357	419	457	863
	Length	–	571	711	–
	Length	–	114	–	–
Upper Leg Ends (mm)	Thread	3/4" - 16 UNF	3/4" - 16 UNF	1-14 UNS	1 1/4" - 12 UNF
Lower Leg Ends (mm)	Thread	5/8" - 18 UNF	5/8" - 18 UNF	1-14 UNS	1 1/4" - 12 UNF
30 Bearing Cup Puller ²⁾	Model Number ▶	BHP180	BHP280	BHP380	BHP580
40 Bearing Separator ²⁾	Model Number ▶	BHP181	BHP282	BHP382	BHP582
• Wooden Case		CM6	CW187	CW350	CW750

¹⁾ Includes Adaptor FZ1055.

²⁾ Can be ordered separately without hydraulic components, see page 163-164.

Cross Bearing Puller Sets



CAUTION! Not all puller components and configurations are rated at the set capacity. Please contact Enerpac for details.



Dimensions

Dimensional information for all puller models is included in the dimensional overview and dimension guide.

Page: **170**

BHP Series



Puller Capacity:

6 - 22 ton

Maximum Reach:

357 - 864 mm

Maximum Spread:

260 - 580 mm

Maximum Operating Pressure:

350 bar



WARNING!

Enerpac cylinder and pump can be operated to 700 bar, but should not be operated past 350 bar pressure when using the cross bearing puller set tools.



Cross Bearing Puller Sets include: ¹⁾

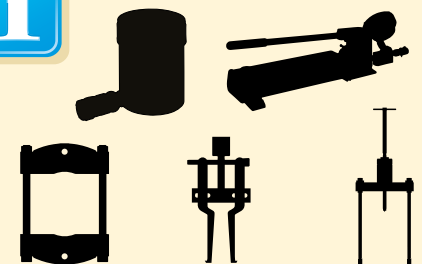

¹⁾ Choose pump options below.

▼ SELECTION CHART

Puller Capacity ¹⁾ (ton)	Cross Bearing only Model Number	Cylinder Stroke (mm)	Maximum Reach A (mm)	Maximum Spread B (mm)	Model Numbers Hydraulic Cross Bearing Puller Sets			
					Hand Pump	Air Driven Foot Pump	Electric Pump ²⁾	Cordless Pump ²⁾
6	BHP1772	25	357	260	BHP162	BHP162A	BHP162EE	BHP162CE
11	BHP262	49	570	345	BHP261G	BHP261GA	BHP261GEE	BHP261GCE
16	BHP362	64	710	440	BHP361G	BHP361GA	BHP361GEE	BHP361GCE
22	BHP562	76	864	580	BHP561G	BHP561GA	BHP561GEE	BHP561GCE

¹⁾ Puller capacity at 540 bar; maximum cylinder capacity is at 700 bar is 60 ton.

²⁾ For 115 Volt application with electric pump change suffix "B" of model nr; example BHPG261GEB
For 230 Volt application with cordless pump change suffix "E" to model nr; example BHP261GCB

▼ Shown: BHP380



Bearing Cup Puller

- Made of high strength steel alloy
- Easily adapted to Cross Bearing Pullers for fast and efficient removal of the most difficult parts
- Adjustable to fit a variety of bearings and seals.

BHP Series



Capacity:

6, 11, 16 and 22 ton

Maximum Reach:

115 - 150 mm

Spread Range:

145 - 240 mm

Maximum Operating Pressure:

350 bar

▼ SELECTION CHART

Capacity *		6 ton	11 ton	16 ton	22 ton
30 Bearing Cup Puller					
Model Number ▶		BHP180	BHP280	BHP380	BHP580
Spread (mm)	Max.	145	160	240	240
	Min.	40	32	60	60
Reach (mm)	Max.	115	140	150	150
	Center Screw Thread	3/4"- 16 UNF	1"- 8 UNC	1 1/4"- 7 UNC	1 5/8"- 5.5 UNS

* Puller capacity, not attachment capacity. See warning on this page.



WARNING

Do not exceed 50% of the rated puller capacity when using a double crosshead (2 grip arms) or when using puller legs in combination with bearing puller attachments.

▼ Shown: BHP382



Bearing Separator

- Made of high strength steel alloy
- Wedge-shaped edges allow removal of the most hard-to-grip components
- Easily adapted to Cross Bearing Pullers for fast and efficient removal of the most difficult parts.

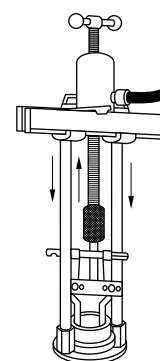

◀ Bearing Cup Puller shown with Crosshead Puller Attachment.

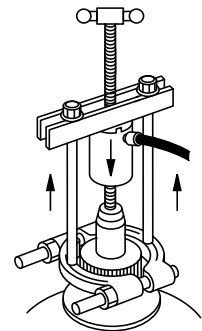

Bearing Separator shown with Crosshead Puller Attachment. ▶

▼ SELECTION CHART

Capacity *		6 ton	11 ton	16 ton	22 ton
40 Bearing Puller					
Model Number ▶		BHP181	BHP282	BHP382	BHP582
Spread (mm)	Max.	110	134	250	250
	Min.	10	12	17	17
Width (mm)		110	155	260	260
Thread		5/8"-18 UNF	3/4"- 18 UNF	1"- 14 UNS	1 1/4"- 12 UNS

* Bearing Separator rated at 50% of puller capacity. See warning on this page.

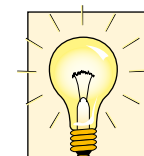

Bearing Separator

Bearing Separator has wedge shaped edges for placing puller behind hard to reach bearings, gears, etc., where clearance prevents direct application of grip puller arms.

The Bearing Separator can be used with the Cross Bearing Puller or the Grip Puller.

Internal & External Mechanical Puller

▼ IPM3 Internal & External Mechanical Puller



- Remove bearings or other shaft-mounted parts where no spindle support is available
- Slide hammer allows for application of safe, high-impact force
- Jaw design provides secure grip
- Includes two sets of jaws for internal and external pulling applications.

IPM Series

Maximum Internal Reach:

45 - 79 mm

Spread Internal Range:

60 - 100 mm

Maximum External Reach:

55 mm

Spread External Range:

15 - 75 mm

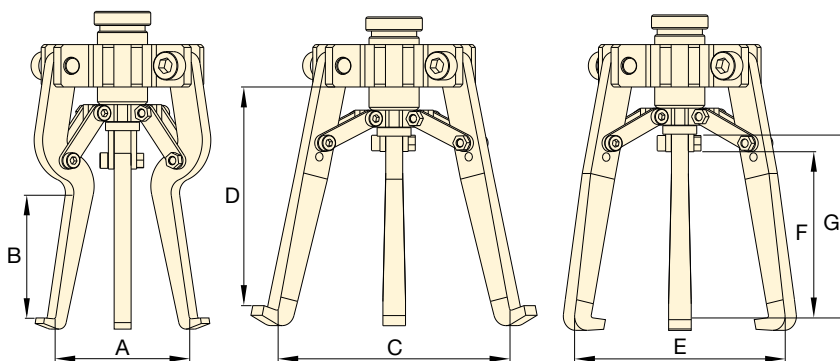
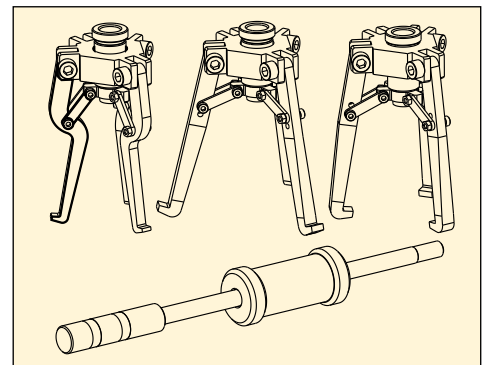

IPM3 Internal

IPM3 External

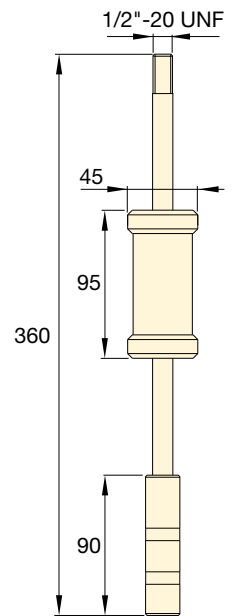

Slide Hammer (1,4 kg)
Dimensions (mm)

Model Number	Internal Jaw Dimensions (mm)			Standard Jaw Dimensions (mm)							
	Minimum Spread Diameter	Maximum Spread Diameter	Maximum Reach	Internal Configuration			External Configuration				
				Minimum Spread Diameter	Maximum Spread Diameter	Maximum Reach	Minimum Spread Diameter	Maximum Spread Diameter	Maximum Reach		
	A	A	B	C	C	D	E	E	F	G	(kg)
IPM3	25	60	45	60	100	79	15	75	55	70	1,9

▼ 2 and 3-Jaw Mechanical Lock-Grip Pullers



- Quickly and easily mount on a wide range of applications
- Lock-on jaws offer a secure grip for safe and easy operation
- Synchronous jaw movement enables entire pulling job to be performed by a single operator
- Available in 2 and 3-jaw configurations.

▼ Lock-Grip Pullers – the simple, safe and cost-effective way to remove shaft-mounted parts.



The simple, safe and cost-effective way to remove shaft-mounted parts

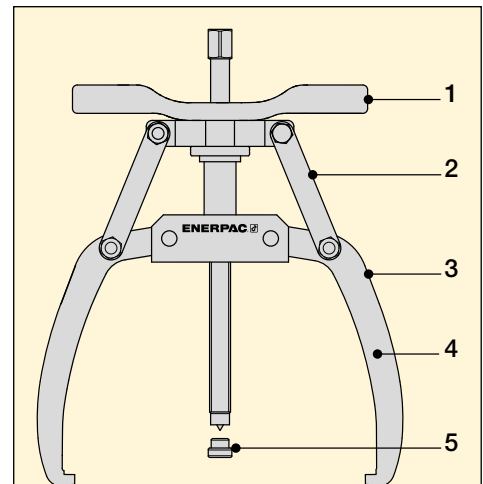

1. Convenient adjustment handle simplifies positioning of jaws on application and increases speed of operation.
2. Locking mechanism helps prevent puller jaws from slipping off application during pulling process.
3. Greater spreading width on top portion of jaws enables use on thicker objects.
4. Synchronous jaw movement increases ease of use, allowing one operator to mount the tool and perform the pulling application.
5. Point protector helps prevent damage to spindle when pulling against a flat surface.

Mechanical Lock-Grip Pullers



LGM-Series, Lock-Grip Pullers

LGM-Series pullers are an ideal solution for pulling small to medium-size wheels, sprockets, bearings and other similar shaft-mounted parts. The puller's self-centering closing system allows all jaws to move simultaneously, making it easy for a single operator to mount the puller and to perform the application.

Turning the puller handle locks the jaws onto the application, allowing the desired object to be pulled free when the spindle is turned.

LGM Series



Puller Capacity:
3 - 40 ton

Maximum Reach:
102 - 335 mm

Maximum Spread:
132 - 635 mm

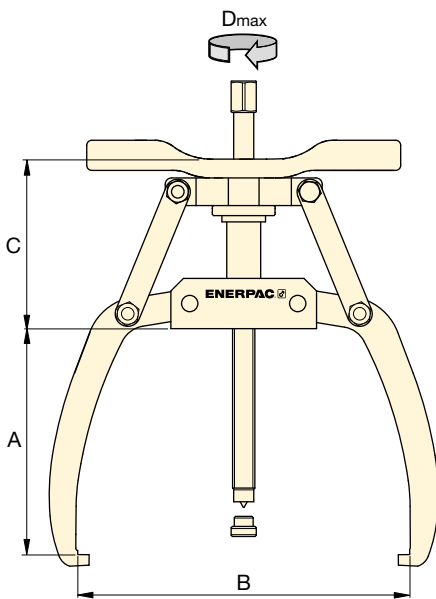

IMPORTANT!

Always wear safety goggles and gloves while using pullers.



Point Protector

LGM-Series Pullers MUST be used with a point protector if the shaft end does not contain a drilled center hole.

One point protector is included with every puller.

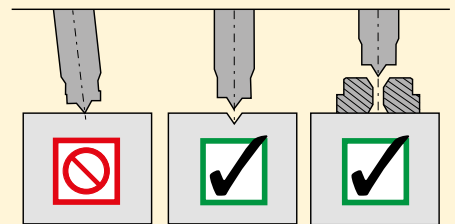

▼ SELECTION CHART

Mechanical Puller Model Number	Maximum Reach A	Dimensions (mm)			Number of Jaws	Puller Capacity US ton (kN)	Maximum Torque Dmax (Nm)	Weight (kg)	Replacement Point Protector Part Number
		Minimum Spread Diameter B	Maximum Spread Diameter B	C					
LGM203	102	28	132	60	2	3 (27)	41	1,7	SGM0404
LGM305	102	28	132	60	3	5 (45)	68	2,1	
LGM204	142	30	186	90	2	4 (36)	68	2,5	
LGM306	142	30	186	90	3	6 (49)	100	3,1	
LGM207	177	35	260	134	2	7 (62)	117	4,9	SGM0704
LGM308	177	35	260	134	3	8 (71)	134	6,9	
LGM211	215	84	300	126	2	11 (98)	203	6,7	
LGM318	215	110	390	140	3	18 (160)	332	9,9	
LGM324	265	90	460	140	3	24 (214)	443	13,9	LGH14K6
LGM340	335	100	635	210	3	40 (356)	996	36,0	LGH24K6

▼ 2 and 3-Jaw Hydraulic Lock-Grip Pullers



The simple, safe and cost-effective way to remove shaft-mounted parts

- Quickly and easily mount on a wide range of applications
- Hydraulically applied pulling force increases pulling capacity, reducing operator fatigue
- Lock-on jaws offer a secure grip for safe and easy operation
- Synchronous jaw movement enables entire pulling job to be performed by a single operator
- Available in 2 and 3-jaw configurations with or without a detachable hollow cylinder.



Point Protector

LGH-Series Pullers **MUST** be used with a point protector if the shaft end does not contain a drilled center hole. One point protector is included with every puller.

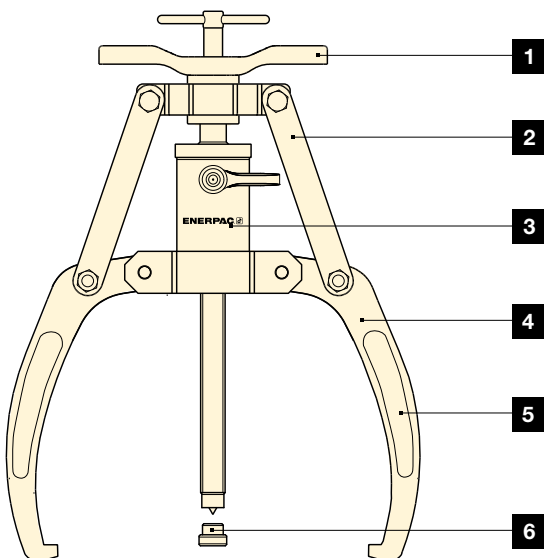
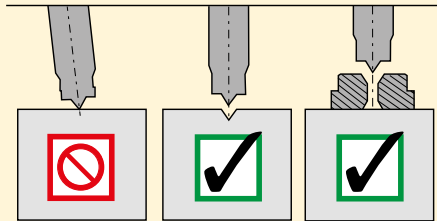

1. Convenient adjustment handle simplifies positioning of jaws on application and increases speed of operation.
2. Locking mechanism helps prevent jaws from slipping off application during pulling process.
3. Detachable hollow cylinder offers increased pulling capacity compared to mechanical alternatives.
4. Greater spreading width on jaws enables use on thicker objects.
5. Synchronous jaw movement increases ease of use, allowing one operator to mount the tool and perform the pulling application.
6. Point protector helps prevent damage to spindle when pulling against a flat surface.

Hydraulic Lock-Grip Pullers & Sets



LGH-Series, Lock-Grip Pullers

LGH-Series pullers provide the same safety and ease of use as their mechanical counterparts, with the pulling force applied by a standard 700 bar hydraulic cylinder.

LGH-Series Lock-Grip pullers can apply up to 64 tons of force and are perfect for removing larger shaft-mounted objects up to 660 mm diameter.

Turning the puller handle locks the jaws onto the application, allowing the desired object to be pulled free when the spindle is turned.

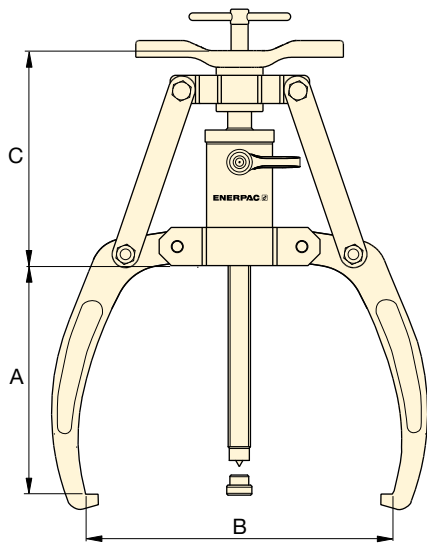

LGH LGHS Series



Puller Capacity:

10 - 64 ton

Maximum Reach:

215 - 408 mm

Maximum Spread:

300 - 660 mm

Maximum Operating Pressure:

700 bar



IMPORTANT!

Always wear safety goggles and gloves while using pullers.



Hydraulic Pullers

LGH-Series Hydraulic Pullers include puller and hydraulic cylinder.

Hydraulic Puller Sets

LGHS-Series Hydraulic Pullers Sets include hydraulic puller, pump, gauge and HC7206C hydraulic hose.

Choose pump options below.

▼ SELECTION CHART

Hydraulic Puller Model Nr ¹⁾	Dimensions (mm)				Number of Jaws	Puller Capacity	Replacement Point Protector Part Number	Hydraulic Puller Sets Model Number				
	Maximum Reach	Minimum Spread Diameter	Maximum Spread Diameter					Hand Pump P392	Air Pump XA11G	Electric Pump PUD1300E*	Cordless Pump XC1201ME*	
	A	B	B	C				Gauge Ass'y GA45GC	Integrated Gauge	Gauge G2535L	Gauge Ass'y GA45GC	
LGH210	215	84	300	192	2	10 (92)	10	SGM0704	—	—	—	—
LGH310	215	84	300	192	3	10 (92)	13	SGM0704	LGHS310H	LGHS310A	LGHS310EE*	LGHS310CE*
LGH214	260	125	380	186	2	14 (125)	14	LGH14K6	—	—	—	—
LGH314	260	125	380	186	3	14 (125)	18	LGH14K6	LGHS314H	LGHS314A	LGHS314EE*	LGHS314CE*
LGH224	336	165	480	325	2	24 (215)	37	LGH24K6	—	—	—	—
LGH324	336	165	480	325	3	24 (215)	47	LGH24K6	LGHS324H	LGHS324A	LGHS324EE*	LGHS324CE*
LGH253	408	230	660	473	2	53 (467)	111	LGH253K6	—	—	—	—
LGH364	408	230	660	473	3	64 (576)	139	LGH253K6	LGHS364H	LGHS364A	LGHS364EE*	LGHS364CE*

¹⁾ Hydraulic puller models include cylinder. To receive puller without cylinder add "NC" after LGH (Example: **LGHNC210**).

* E = for 230V applications. For 115V applications change last suffix from E into B. Example **LGHS310EB**.

Master Puller Sets include a hydraulic puller, cylinder, a pump with hose and gauge for standard pulling applications, as well as a selection of accessories designed for work environments where clearance prevents a direct application of the puller jaws.



Lock-Grip Pullers:

All sets come with a hydraulic LGH-Series Puller. Both two jaw and three jaw versions are available.



Detachable RCH-Hollow Cylinder:

Provided with all hydraulic pullers as well as the Cross Bearing Puller.



Pump with Hose and Gauge:

Hydraulic Puller Sets and Master Puller Sets are supplied with a hose, gauge, and your choice of a hand, air, electric or battery-powered cordless pump.



BHP-Cross Puller:

Hydraulically powered via a detachable hydraulic cylinder and pump. The Cross Puller can be used individually as a 'push' puller, or in conjunction with the Bearing Separator or Bearing Cup Puller.

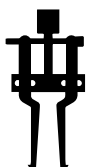

BHP-Bearing-Cup Puller:

Specifically designed to pull cup style bearings and other applications requiring an internal style puller.

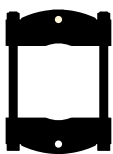

BHP-Bearing Separator

(used with BHP-Cross Bearing Puller):

Features narrow edges, which enable puller to be placed behind hard to reach bearings, gears, etc., where limited clearance prevents the direct application of puller arms.

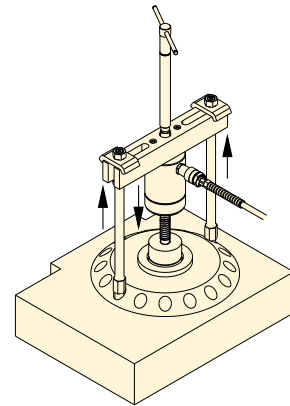

▲ Cross Bearing puller on application

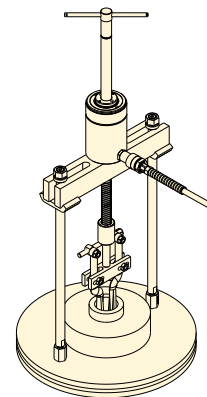

▲ Cross Bearing Puller with Bearing Cup Puller on application

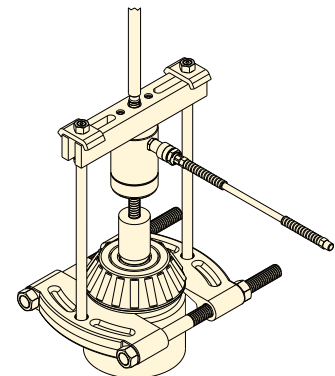

▲ Cross Bearing Puller with Bearing Separator on application

▼ DIMENSIONAL INFORMATION

Model Number	Cross Bearing Puller (mm)				(kg) *
	A	B min.	Thread Size C		
BHP112	280	115	5/8"-18 UNF		2,0
BHP172	280	115	5/8"-18 UNF		2,1
BHP272	370	140	5/8"-18 UNF		2,4
BHP672	615	220	1 1/4"-12 UNF		6,4

Model Number	Bearing Separator (mm)					(kg)
	A	B min.	B max.	Thread Size C		
BHP181	110	10	110	5/8"-18 UNF		2,8
BHP282	156	12	134	5/8"-18 UNF		5,7
BHP292	182	13	210	5/8"-18 UNF		12,5
BHP682	300	20	300	1 1/4"-12 UNF		43,5

Model Number	Bearing Cup Puller (mm)					(kg)
	A	B	C min.	C max.		
BHP180	135	236	40	145		2,0
BHP190	164	265	40	145		2,0
BHP280	164	265	40	145		2,4
BHP580	150	310	60	240		6,4

* With slotted crosshead, cylinder and spindle.

Hydraulic Lock-Grip Master Puller Sets

▼ LGHMS Master Puller Set with Hand Pump Option



LGHMS Series

Puller Capacity:
10 - 64 ton

Maximum Reach:
215 - 408 mm

Maximum Spread:
300 - 660 mm

Maximum Operating Pressure:
700 bar



Puller Dimensions

See dimensional information for LGH-pullers on page 168. For dimensions of BHP-puller attachments, see page 170.



LGH-Series, Hydraulic Pullers

Hydraulic Pullers include puller and hydraulic cylinder.

LGHMS-Series, Hydraulic Master Puller Sets

Hydraulic Master Pullers Sets include LGH-hydraulic puller, pump, gauge and HC7206C hydraulic hose. Choose pump options below.

- All LGHMS-Series Master Puller Sets include an LGH-Series Hydraulic Puller with 3 jaws, a Cross Puller, a Bearing Separator, a Bearing Cup Puller, a detachable Hollow Cylinder, a hose, a gauge and a pump
- Set options include hand, air, electric or battery-powered pump for an optimal solution to every application.



WARNING!

Enerpac hydraulic pullers can be operated upto 700 bar. When using accessories, hydraulic pressure **MUST BE LIMITED** to maximum capacities below.

▼ SELECTION CHART

Hydraulic Puller Capacity	Hydraulic Master Puller Sets Model Numbers				Master Puller Sets include following components					
	Hand Pump P392 Gauge Ass'y GA45GC	Air Pump XA11G Integrated Gauge	Electric Pump PUD1300E* Gauge G2535L	Cordless Pump XC1201ME* Gauge Ass'y GA45GC	Hydraulic Hose Model Nr.		US-ton (kN)			
10 (92)	LGHMS310H	LGHMS310A	LGHMS310EE*	LGHMS310CE*	HC7206C	LGH310	7 (75)	BHP112	BHP181	BHP180
14 (125)	LGHMS314H	LGHMS314A	LGHMS314EE*	LGHMS314CE*	HC7206C	LGH314	7 (75)	BHP172	BHP282	BHP190
24 (215)	LGHMS324H	LGHMS324A	LGHMS324EE*	LGHMS324CE*	HC7206C	LGH324	12 (107)	BHP272	BHP292	BHP280
64 (576)	LGHMS364H	LGHMS364A	LGHMS364EE*	LGHMS364CE*	HC7206C	LGH364	25 (227)	BHP672	BHP682	BHP580

* E = for 230V applications. For 115V applications change last suffix from E into B. Example: LGHMS310CB.

Overview and Dimension Guide

The Enerpac Sync-Grip multi-purpose puller range is designed to make your jobs easier and safer to accomplish.

Remove bearings, bushings, gears, sleeves, wheels and flywheels, sprockets and other shaft mounted items simply and effectively.

Mechanical and hydraulic configurations are available with a variety of optional accessories that expand application range and increase utility.

Hydraulic models are available in standard sets which include detachable hydraulic cylinders and a choice of pump options, along with a gauge assembly and hose for safe monitoring of applied pulling forces.

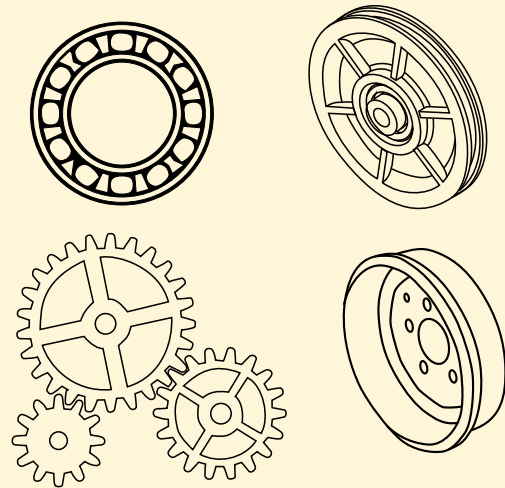

IMPORTANT!

Always wear Safety Goggles and Gloves while using pullers.



WARNING!

Do not exceed 50% of the rated puller capacity when using two jaw configurations.

▼ OVERVIEW AND DIMENSION GUIDE

Puller Capacity (ton)	Puller Model Number	Sync Grip Pullers Dimensions (mm)										Page:
		With Standard Jaws		With Optional Extended Jaws		Height D	Jaw Tip		Jaw Hole Spacing H	Weight (kg**)		
Max. Reach A	Max. Spread B	Max. Reach A	Max. Spread B	Width E	Thick-ness F							
Mechanical Pullers												
1	SGM01 *	105	110	–	–	8,0	7,0	7,5	19,0	0,8	174 ▶	
4	SGM04 *	185	175	–	–	7,5	8,0	21,0	51,0	2,0	174 ▶	
7	SGM07 *	225	240	–	–	10,0	8,0	25,0	44,5	6,5	174 ▶	
10	SGM10 *	410	350	490	405	12,5	15,0	25,0	83,0	14,5	174 ▶	
20	SGM20	600	680	640	720	22,0	24,0	41,0	125,0	55,5	174 ▶	
Hydraulic Pullers												
13	SGH14	320	350	400	405	12,5	15,0	25,0	83,0	25	175-176 ▶	
22	SGH24	320	480	435	540	15,5	17,5	31,0	115,0	49	175-176 ▶	
33	SGH36	410	650	525	720	22,0	24,0	41,0	125,0	75	175-176 ▶	
45 **	SGH64	700	980	850	1080	30,0	27,0	50,0	150,0	165	175-176 ▶	
100	SGH100	1000	1600	–	–	46,0	49,0	70,0	250,0	322	177 ▶	

* Puller can be set up as a 2 or 3 jaw configuration.

** Puller capacity at 540 bar, maximum cylinder capacity at 700 bar is 54 ton.

** Weight of SGH-models with standard legs and hydraulic cylinder.

SG-Series, Sync-Grip Pullers



SG-Series Sync-Grip Pullers: available in both mechanical or hydraulic versions. Some models can be configured as a two jaw puller, however, three jaws are recommended for most even distribution of pulling forces.



BHP-Cross Puller: hydraulically powered via detachable cylinder and choice of pump. The Cross Puller can be used individually as a 'push' puller or in conjunction with the Bearing Separator or Bearing Cup Puller.



BHP-Bearing Separator: use where access is restricted. The Bearing Separator is used in conjunction with the Cross Puller.



BHP-Bearing Cup Puller: specifically designed for cup style bearing and other applications requiring an internal style puller.



Detachable RCH-Hollow Cylinder: provided with all hydraulic puller models including both the standard Sync Grip and Cross Puller.



In Sync-Grip, Cross Bearing and Master Puller Sets a hose and gauge are provided as standard along with your choice of pump including manual hand operated, cordless battery powered, electric or air powered. In each case the pump selection has been optimized for compatibility with the pullers.



Easy To Use

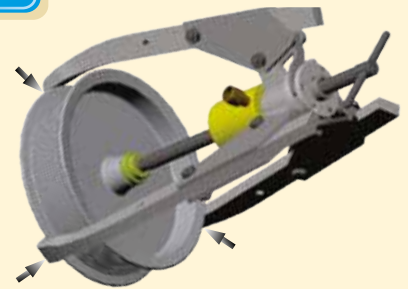

Simple, Safe, Productive

All three jaws close simultaneously making the puller easier and safer to operate.

The synchronous feature of the SGM and SGH-Series Sync-Grip Pullers makes positioning the puller simple and helps prevent misalignment.

▼ OVERVIEW AND DIMENSION GUIDE

Puller Capacity (ton)	Cross Bearing Pullers Dimensions (mm)			(kg**)
	Standard Leg Height A	Long Leg Height A	Max. Spread B	
Mechanical Pullers				
-	-	-	-	-
-	-	-	-	-
-	-	-	-	-
-	-	-	-	-
-	-	-	-	-
Hydraulic Pullers				
13	106	357	260	18,5
22	115	570	345	34,5
33	205	710	440	56,0
45 *	609	864	580	113,5
-	-	-	-	-

Bearing Separators Dimensions (mm)				(kg)
Dia-meter A	Min. Spread B	Max. Spread B	Thread Size C	
Mechanical Pullers				
-	-	-	-	-
-	-	-	-	-
-	-	-	-	-
-	-	-	-	-
-	-	-	-	-
Hydraulic Pullers				
110	10	110	5/8"-18UNF	2,7
155	12	134	5/8"-18UNF	5,7
260	17	250	1"-14UNS	28,5
260	17	250	1 1/4"-12UNF	28,5
-	-	-	-	-

Bearing Cup Pullers Dimensions (mm)							(kg)
Height A	Height B	Min. Spread C	Max. Spread C	Tip Height D	Tip Width E	Thick-ness F	
Mechanical Pullers							
-	-	-	-	-	-	-	-
-	-	-	-	-	-	-	-
-	-	-	-	-	-	-	-
-	-	-	-	-	-	-	-
-	-	-	-	-	-	-	-
Hydraulic Pullers							
115	237	40	145	5,0	4,5	31	2,0
140	266	32	160	4,5	4,5	25	2,4
150	310	60	240	8,0	11,0	55	6,0
150	310	60	240	8,0	11,0	55	6,4
-	-	-	-	-	-	-	-

** With standard legs and hydraulic cylinder.

▼ SGM10 Mechanical Sync-Grip Puller with three jaws



- Sync-Grip mechanism synchronizes movement of all jaws for simultaneous engagement, helping to prevent misalignment for safe and easy use
- Threaded spindle and jaw indexes provide adjustable reach
- Three-jaw configuration for even load distribution
- Two-jaw configuration for confined access applications available on pullers of 1 to 10 ton (not available on SGM20)
- High-strength forged jaws for superior reliability
- Suitable for a variety of applications including bearings, bushings, wheels, gears and pulleys.

SGM Series

Puller Capacity:
1 - 20 ton

Maximum Reach:
105 - 600 mm

Maximum Spread:
110 - 680 mm



Dimensions

Dimensional information for all puller models is included in the dimensional overview and dimension guide.

Page: **172**



IMPORTANT!

Always wear Safety Goggles and Gloves while using pullers.



WARNING!

Do not exceed 50% of the rated puller capacity when using two jaw configurations.

▼ SGM10 with two jaws.



▼ SELECTION CHART

Puller Capacity (ton)	3-Jaw Puller Model Number	Max. Reach	Max. Spread		Optional Long Jaw Sets (3 jaws) Model Number	Max. Reach	Max. Spread
		A (mm)	B (mm)			(kg)	A (mm)
1	SGM01 *	105	110	0,8	—	—	—
4	SGM04 *	185	175	2,0	—	—	—
7	SGM07 *	225	240	6,5	—	—	—
10	SGM10 *	410	350	14,5	SG1002K	490	405
20	SGM20	600	680	55,5	SG3002K	640	720

* Can be configured into 2-jaw puller.

Hydraulic Sync-Grip Master Puller Sets

▼ MPS14H



MPS, SGH Series

Puller Capacity:
13 - 45 ton

Maximum Reach:
320 - 700 mm

Maximum Spread:
350 - 980 mm

Maximum Operating Pressure:
700 bar



Dimensions

Dimensional information for all puller models is included in the dimensional overview and dimension guide.

Page: 172

- Sync-Grip mechanism synchronizes movement of all jaws for simultaneous engagement
- Hydraulically applied pulling force increases pulling capacity reducing operator fatigue
- Standard jaws adjust to accommodate different reach requirements. Optional long jaws sets available for additional reach requirements
- Designed for applications including pulling, pushing and dismounting gears, bearings, bushings, etc.



100 ton Sync-Grip Puller Sets

The hydraulic SGH-puller is also available with 100 ton capacity.

Page: 177



Master Puller Sets include: ¹⁾

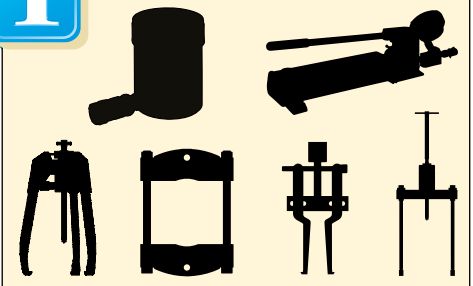

¹⁾ Choose pump options below.

▼ SELECTION CHART

Puller Capacity (ton)	3-Jaw Puller only Model Number *	Cylinder Stroke (mm)	Max. Reach A (mm)	Max. Spread B (mm)	Weight (kg)	Model Numbers Hydraulic Sync-Grip Master Puller Sets					Optional Long Jaw Sets (3 jaws) Model Number	Max. Reach A (mm)	Max. Spread B (mm)
						Hand Pump	Air Driven Foot Pump	Electric Pump ³⁾	Cordless Pump ³⁾	All Sets include			
13	SGH14	25	320	350	25	MPS14H	MPS14A	MPS14E	MPS14C	¹⁾	SG1002K	400	405
22	SGH24	49	320	480	49	MPS24H	MPS24A	MPS24E	MPS24C	GA45GC with HC7206C	SG2002K	435	540
33	SGH36	64	410	650	75	MPS36H	MPS36A	MPS36E	MPS36C		SG3002K	525	720
45 ²⁾	SGH64	76	700	980	165	MPS64H	MPS64A	MPS64E	MPS64C		SG6002K	850	1080

¹⁾ 13 ton sets include an AR630 female coupler, GA45 gauge adaptor and G2535L gauge.

²⁾ Puller capacity at 540 bar; maximum cylinder capacity is at 700 bar is 60 ton.

³⁾ For 115 Volt application with electric pump add suffix "B" to model nr; example MPS24EB
For 230 Volt application with cordless pump add suffix "E" to model nr; example MPS14CE

▼ GPS14H Hydraulic Sync-Grip Puller Set

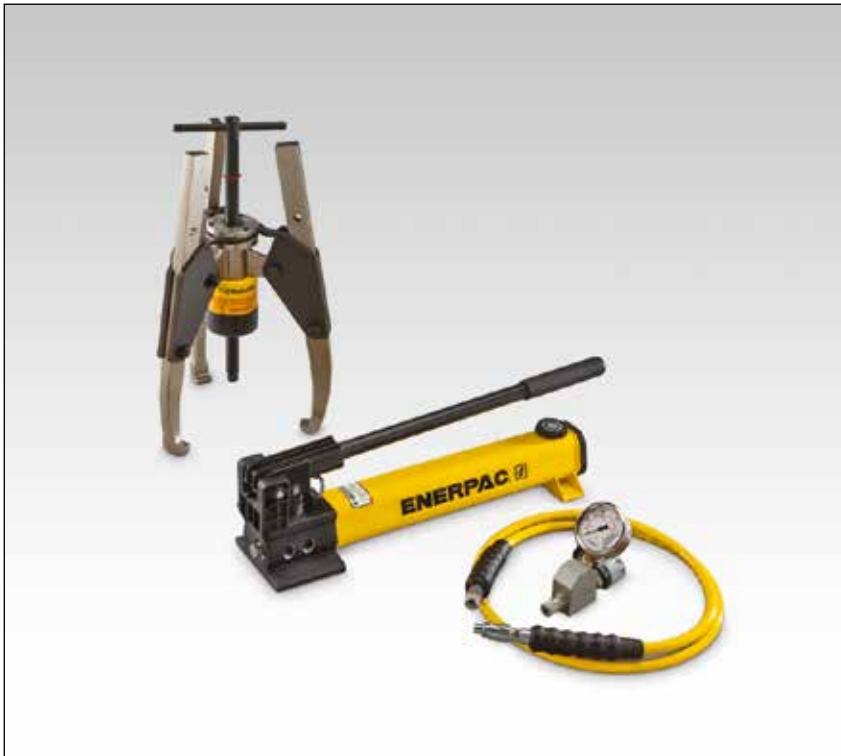

GPS, SGH Series

Puller Capacity:
13 - 45 ton

Maximum Reach:
320 - 700 mm

Maximum Spread:
350 - 980 mm

Maximum Operating Pressure:
700 bar



Dimensions

Dimensional information for all puller models is included in the dimensional overview and dimension guide.

Page: **172**

- Sync-Grip mechanism synchronizes movement of all jaws for simultaneous engagement
- Hydraulically applied pulling force increases pulling capacity and reduces operator fatigue
- Threaded spindle and jaw indexes provide adjustable reach
- Three jaw configuration for even load distribution
- High strength forged jaws for superior reliability
- The versatile puller set facilitates safe and easy dismantling in a variety of applications.



IMPORTANT!

Always wear Safety Goggles and Gloves while using pullers.



Grip Puller Sets include: ¹⁾



¹⁾ Choose pump options below.

▼ SELECTION CHART

Puller Capacity (ton)	3-Jaw Puller only Model Number *	Cylinder Stroke (mm)	Max. Reach A (mm)	Max. Spread B (mm)	Weight (kg)	Model Numbers Hydraulic Sync-Grip Puller Sets					Optional Long Jaw Sets (3 jaws) Model Number	Max. Reach A (mm)	Max. Spread B (mm)
						Hand Pump P142	Air Driven Foot Pump XA11G	Electric Pump ³⁾ PUD1300	Cordless Pump ³⁾ XC1201M	All Sets include			
13	SGH14	25	320	350	25	GPS14H	GPS14A	GPS14E	GPS14C	¹⁾	SG1002K	400	405
22	SGH24	49	320	480	49	GPS24H	GPS24A	GPS24E	GPS24C	GA45GC + HC7206C	SG2002K	435	540
33	SGH36	64	410	650	75	GPS36H	GPS36A	GPS36E	GPS36C		SG3002K	525	720
45 ²⁾	SGH64	76	700	980	165	GPS64H	GPS64A	GPS64E	GPS64C		SG6002K	850	1080

¹⁾ 13 ton sets include an AR630 female coupler, GA45 gauge adaptor and G2535L gauge.

²⁾ Puller capacity at 540 bar; maximum cylinder capacity is at 700 bar is 60 ton.

³⁾ For 115 Volt application with electric pump add suffix "B" to model nr; example GPS24EB
For 230 Volt application with cordless pump add suffix "E" to model nr; example GPS14CE

100 ton Hydraulic Sync-Grip Puller & Sets

▼ SGH100 100 ton Hydraulic Sync-Grip Puller



- **Sync-Grip mechanism synchronizes movement of all jaws, providing enhanced control of pulling process**
- **No need to cut, heat or torch components for removal, resulting in safer environment for operator, and preventing damage to equipment**
- **A hydraulically applied pulling force of up to 100 ton allows a traditionally strenuous task to be completed at the push of a button**
- **Provides 100 ton pulling force at a fraction of the price of alternative solutions**
- **One SGH10004 point protector is included with each SGH100.**

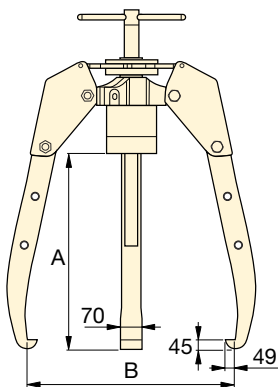

Number of Jaws	Capacity ton (kN)	Model Number *	Maximum Reach A (mm)	Maximum Spread B (mm)	Cylinder Stroke (RCH1003) (mm)	 (kg)
3	100 (980)	SGH100	1000	1600	76	322

* Available as complete set. Total set weight 459 kg.

SGH, GPS Series

Capacity:
100 ton

Maximum Reach:
1000 mm

Spread Range:
1600 mm

Maximum Operating Pressure:
700 bar



Sync-Grip Puller – Simple, synchronous movement

The Sync Grip mechanism synchronizes movement of all jaws for simultaneous engagement, allowing one operator to mount the tool and perform the pulling application. Hydraulically applied pulling force increases pulling capacity and reduces operator fatigue, enabling quicker and easier set up.



100 ton Sync-Grip Puller Sets

For ordering convenience the SGH100 is available as complete set with HC7206C hose, GA45GC gauge adapter assembly and ZE3304S electric pump.

Model Nr.	Description
GPS100EB	Set with 115 V pump
GPS100EE	Set with 230 V pump



Point Protector

To prevent damage a point protector must be used if the shaft end does not have a drilled center hole.

Model Nr.	Description
SGH10004	Point protector for SGH100

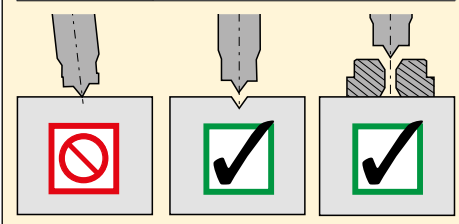

Enerpac offers an extensive range of dedicated tools for a variety of specific and flexible applications.

Whatever your requirement... cutting, punching, spreading or bending... you can be sure that Enerpac has the correct tool to do your job safely and efficiently.

Featuring maintenance sets, machine lifts and machine skates, as well as hole punches, pipe benders and rail stressor, Enerpac has the tools to ensure that even your most demanding applications can be undertaken with the highest degree of safety and accuracy.

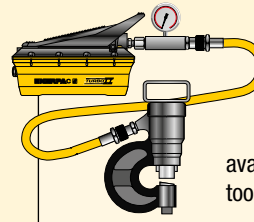

Tool-Pump Sets

Most hydraulic tools in this section are available in sets, for a perfect tool-pump match.



Hydraulic System Set-up

Check out our 'Yellow Pages' section for help on system set-ups and valving configurations.

Page: 410



Hydraulic, Electric and Manual Cutters

Enerpac Cutters can be found in the Cutter section of this catalog.

Page: 200













Bolting Tools

More Enerpac Tools you will find in our Bolting Tools section in this catalog.

Page: 218



Specialty Tools Section Overview

Capacity ton (kN)	Tool type and functions	Series		Page
2,5 - 12,5 (22 - 116)	Maintenance Sets	MS		180 ▶
35 - 50 (311 - 498)	Punches Punch-Pump Sets	SP, MSP, STP		184 ▶ 186 ▶
16 (157)	Lifting Wedge	LW		188 ▶
8,5 - 20 (75 - 178)	Machine Lifts	SOH		189 ▶
3 - 32 (29 - 314)	Wheeled Machine Skates	MLS		190 ▶
1 - 80 (8,9 - 712)	Heavy-Duty Chain Roller Machine Skates	ER, ES ELP		192 ▶
19 - 453 litres	Industrial Storage Cases	CM		194 ▶
0,75 - 1,0 (6 - 8,9)	Hydraulic Wedgie Spread Cylinders	A WR		195 ▶
Nominal Pipe Bore ½ - 4 inch	Pipe Bender Sets	STB		196 ▶
70 (683)	Hydraulic Rail Stressor	RP		198 ▶

▼ Shown: MS210



- All sets include Enerpac pump, hose, cylinder and gauge
- Lock-on or threaded connectors
- Complete maintenance set for almost every maintenance application.

The Universal Hydraulic Tool Box



Maintenance Sets

Enerpac Maintenance sets are a complete assortment of hydraulic powered tools. Using these sets allows you to quickly configure a unique tool to meet your most difficult jobs.

Built around the Enerpac lightweight hand pump, hose and cylinder, these sets enable you to push, pull, lift, press, straighten, spread and clamp with forces up to 12,5 ton.



More Information

For detailed information on all included attachments, see the next pages.

Page: 182



Clamping a workpiece is just one of the many applications for the Enerpac maintenance sets.

▼ QUICK SELECTION CHART

Capacity using attachments* ton (kN)	Set Model Number						Number of Attachment Components	 (kg)
2,5 (22)	MS24	P142	HC7206	RC55	GP10S	GA4	33	26
2,5 (22)	MSFP5	P142	HC7206	RC55	GP10S	GA4	24	20
5,0 (50)	MSFP10	P392	HC7206	RC106	G2535L	GA3	23	48
5,0 (50)	MS210	P392	HC7206	RC106	GP10S	GA2	35	63
12,5 (116)	MS220	P392	HC7206	RC256	GP10S	GA2	13	95
5,0-12,5 (50-116)	MS21020	P392	HC7206	RC102, 106, 256	GP10S	GA2	53	158

* If no attachments are being used, capacity is double these values. Maximum operating pressure is then 700 bar.

Universal Maintenance Sets



CAUTION!
When cylinders are used with maintenance set attachments or components, the maximum system pressure must be limited to half the rated pressure (350 bar).



WARNING!
Only use attachments provided with set.
Non-Enerpac attachments and longer extension tubes will reduce column strength, potentially creating unsafe conditions.

MS Series



Capacity (using attachments):

2,5 - 12,5 ton

Maximum Operating Pressure:

350 bar

▼ APPLICATION EXAMPLES





CAUTION! When cylinders are used with maintenance set attachments or components, the maximum system pressure must be limited to half the rated pressure (350 bar).

Note: All dimensions in millimetres.

Set Model Number	MS24	MSFP5	MSFP10	MS210	MS220	MS21020
Base, Collar and Plunger Attachments	2,5 ton	2,5 ton	5,0 ton	5,0 ton	12,5 ton	5,0 - 12,5 ton
Cylinder Model(s)	RC55	RC55	RC106	RC106	RC256	RC102, 106, 256
1	A23	A23	A13	A13	A28	A13, A28
2	A25	A25	A21	A21	A27	A21, A27
3	A1034	A1034	A20	A20	A595	A20, A595
4	MZ4010	MZ4010	A14	A14	A243	A14, A243
5	A545	A545	A10	A10	-	A10 (2x)
6	-	-	-	A8	-	A8
7	A530	A530	A6	A6	-	A6
8	MZ4011	-	-	A192	-	A192
9	-	-	-	A305	-	A305
10	A531	A531	A18	A18	-	A18
11	-	-	-	A185	-	A185
12	A532	A532	A15	A15	-	A15
13	-	-	-	-	A607	A607
14	A629	A629	A129	A129	-	A129
15	A539	A539	A128	A128	-	A128
Chains and Attachments for Pulling Applications	2,5 ton	2,5 ton	5,0 ton	5,0 ton	12,5 ton	5,0 - 12,5 ton
16	A558	-	-	A132	A238	A132, A238
17	-	-	-	A5 (2x)	-	A5 (2x)
18	A557 (2x)	-	-	A141 (2x)	A218 (2x)	A141 (2x), A18 (2x)
Extension Tubes, Connectors and Adaptors	2,5 ton	2,5 ton	5,0 ton	5,0 ton	12,5 ton	5,0 - 12,5 ton
19	A544	-	-	A19 (2x)	A242 (2x)	A19 (2x) A242 (2x)
20	WR5	WR5	WR5	A92	-	A92
21	MZ4013 (4x)	MZ4013 (4x)	A16 (4x)	A16 (4x)	-	A16 (4x)
22	MZ4007 (3x)	MZ4007 (3x)	MZ1050 (3x)	MZ1050 (2x)	-	MZ1050 (3x)
23	MZ4008 (2x)	-	-	MZ1051	-	MZ1051 (2x)
24	MZ4009	MZ4009	MZ1052	MZ1052	-	MZ1052
25	-	-	-	A285	-	A285
26	A650	-	-	-	-	-
27 Length (mm)	76	MZ4002	MZ4002	-	-	-
	127	MZ4003	MZ4003	MZ1002	MZ1002	-
	254	MZ4004	MZ4004	MZ1003	MZ1003	A239
	254	-	-	-	-	A239
	457	MZ4005 (2x)	MZ4005	MZ1004	MZ1004	A240
	457	-	-	-	-	A240
	584	MZ4006	MZ4006	-	-	-
762	-	-	MZ1005	MZ1005	A241	MZ1005 (2x)
762	-	-	-	-	-	A241
28 Storage Case	CM6	CM6	CW350	CW350	CW350	CW750
Set Weight (kg)	26	20	48	63	95	158

Base, Collar and Plunger Attachments

1 Threaded Adaptor

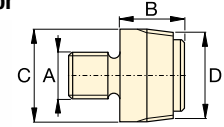

ton	Model Nr.	A	B	C	D
2,5	A23	3/4" - 16 UN	28	26	3/4" - 14 NPT
5,0	A13	1" - 8 UN	31	42	1 1/4" - 11 1/2 NPT
12,5	A28	1 1/2" - 16 UN	47	69	2" - 11 1/2 NPT

2 Base Attachment

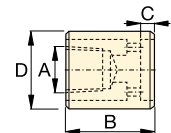

ton	Model Nr.	A	B	C	D
2,5	A25	3/4" - 14 NPT	50	12	44
5,0	A21	1 1/4" - 11 1/2 NPT	57	12	65
12,5	A27	2" - 11 1/2 NPT	63	12	98

3 Collar Toe

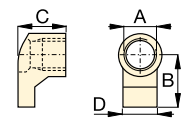

ton	Model Nr.	A	B	C	D
2,5	A1034	1 1/2" - 16 UN	54	50	31
5,0	A20	2 1/4" - 14 UN	80	57	57
12,5	A595	3 5/16" - 12 UN	103	51	80

4 Flat Base

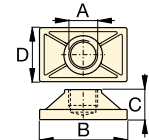

ton	Model Nr.	A	B	C	D
2,5	MZ4010	3/4" - 14 NPT	114	31	63
5,0	A14	1 1/4" - 11 1/2 NPT	165	35	88
12,5	A243 *	2" - 11 1/2 NPT	165	58	165

* A243 is a round base model.

5 Threaded Connector

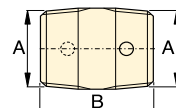

ton	Model Nr.	A	B
2,5	A545	3/4" - 14 NPT	35
5,0	A10	1 1/4" - 11 1/2 NPT	41

6 Lock-on Clamp Toe

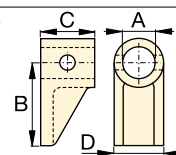

ton	Model Nr.	A	B	C	D
5,0	A8	43	105	50	57

Universal Maintenance Sets, MS-Series

7 Threaded Plunger Toe

ton	Model Nr.	A	B	C	D
2,5	A530	¾" - 14 NPT	57	25	33
5,0	A6	1¼" - 11½ NPT	82	31	57

14 Wedge Head

ton	Model Nr.	A	B	C	D
2,5	A629	¾" - 14 NPT	69	33	28
5,0	A129	1¼" - 11½ NPT	101	50	44

20 Spreader

ton	Model Nr.	A	B	C	D
1,0	WR5	—	223	12,8	94
1,0	A92	2¼" - 14 UN	244	35	158

8 Collar Clamp Head

ton	Model Nr.	A	B	C	D
2,5	MZ4011	¾" - 14 NPT	49	76	1½" - 16 UN
5,0	A192	—	42	63	2¼" - 14 UN

15 Rubber Flex Head

ton	Model Nr.	A	B	C
2,5	A539	¾" - 14 NPT	44	69
5,0	A128	1¼" - 11½ NPT	86	86

21 Lock Pin

ton	Model Nr.	A	B
2,5	MZ4013	7,9	41
5,0	A16	11,2	82

9 Spreader Toe

ton	Model Nr.	A	B	C	D
5,0	A305	1¼" - 11½ NPT	114	25	50

Chains and Attachments for Pulling

16 Single Chain Plate

ton	Model Nr.	A	B	C	D
2,5	A558	1½" - 16 UN	196	39	44
5,0	A132	2¼" - 14 UN	307	63	79
12,5	A238	3⅝" - 12 UN	450	102	125

17 Double Chain Plate

ton	Model Nr.	A	B	C	D
5,0	A5	1¼" - 11½ NPT	130	50	126

18 Chain with Hook

ton	Model Nr.	Chain Length
2,5	A557	1,5 metres
5,0	A141	1,8 metres
12,5	A218	2,4 metres

Tubes, Connectors and Adaptors

19 Pipe Coupling

ton	Model Nr.	A	B	C
2,5	A544	¾" - 14 NPT	42	33
5,0	A19	1¼" - 11½ NPT	49	54
12,5	A242	2" - 11½ NPT	88	82

22 Lock-on Connector

ton	Model Nr.	A	B
2,5	MZ4007	19	79
5,0	MZ1050	33	127

23 Male Lock-on Adaptor

ton	Model Nr.	A	B	C
2,5	MZ4008	¾" - 14 NPT	60	19
5,0	MZ1051	1¼" - 11½ NPT	90	33

24 Female Lock-on Adaptor

ton	Model Nr.	A	B	C
2,5	MZ4009	¾" - 14 NPT	65	19
5,0	MZ1052	1¼" - 11½ NPT	96	33

25 Adjustable Extension

ton	Model Nr.	A	B	C	D
5,0	A285	1¼" - 11½ NPT	335	441	33

26 Slip-on Extension

ton	Model Nr.	A	B	C
2,5	A650	¾" - 14 NPT	200	365

10 Serrated Saddle

ton	Model Nr.	A	B	C
2,5	A531	¾" - 14 NPT	27	31
5,0	A18	1¼" - 11½ NPT	38	50

11 Smooth Saddle

ton	Model Nr.	A	B	C
5,0	A185	1¼" - 11½ NPT	38	50

12 90° V-Base

ton	Model Nr.	A	B	C	D
2,5	A532	¾" - 14 NPT	38	47	25
5,0	A15	1¼" - 11½ NPT	54	57	54

13 Plunger Base

ton	Model Nr.	A	B	C
12,5	A607	2" - 11½ NPT	166	38

▼ Shown: SP35S



- 12,7 mm thick capacity through mild steel
- Round, oblong and square punches and dies are available to solve your punching applications
- Long life Enerpac single-acting, spring return design
- Durable steel case keeps tools and dies together and provides for easy carrying and storage
- CR400 coupler included.

▼ SP-Series, Lightweight Hydraulic Punch – Much Faster than Drilling.



Much Faster than Drilling



Tool Kit SPK10

Included with all 35 Ton punches, this tool kit is used to remove and install the punch into the head. Can be ordered as a replacement under model number **SPK10**.



Ordering Information

The 35 ton hydraulic Punch may be ordered by itself or as a set, including a pump. A punch or die may also be ordered separately or as a matched set. Please refer to the Quick Selection Chart information on top of the next page.



▼ STANDARD PUNCHES AND DIES SELECTION CHART

Hole Shape	Imperial ¹⁾ (inch)		Metric ¹⁾ (mm)	
	Hole Size	Bolt Size	Hole Size	Bolt Size
●	0,31	1/4	7,9	–
●	0,38	5/16	9,5	M8
●	0,44	3/8	11,1	M10
●	0,53	7/16	13,5	M12
●	0,56	1/2	14,3	–
●	0,69	5/8	17,5	M16
●	0,78	–	19,8	M18
●	0,81	3/4	20,6	–
■	0,31	1/4	7,9	–
■	0,38	5/16	9,5	M8
■	0,44	3/8	11,1	M10
■	0,50	7/16	12,7	M12
■	.31 x .75	1/4	7,9 x 19	–
■	.38 x .75	5/16	9,5 x 19	M8
■	.44 x .75	3/8	11,1 x 19	M10
■	.50 x .75	7/16	12,7 x 19	M12

¹⁾ Material thickness should not exceed hole diameter

Single-Acting, Spring Return Hydraulic Punch

▼ QUICK SELECTION CHART

* 	Punch & Die Set	Included				Model Number	 (kg)
		Pump	Hose	Gauge	Gauge Adaptor		
SP35	Standard**	P392	HC7206	GP10S	GA2	STP35H	25
SP35	Standard**	PATG1102N	HC7206	GP10S	GA2	STP35A	29
SP35	-	-	-	-	-	SP35	16
SP35	Standard**	-	-	-	-	SP35S	18
SP35	Standard**	PUD1100E	HC7206	-	-	SP35SPE	29
SP35	Metric***	-	-	-	-	MSP351	21
SP35	Metric***	PUD1100E	HC7206	-	-	MSP351PE	32

* Punch oil capacity: 76 cm³

Includes the following punch and die sets:

** SPD438, SPD688, SPD563 and SPD813

*** SPD375, SPD531, SPD438 and SPD688

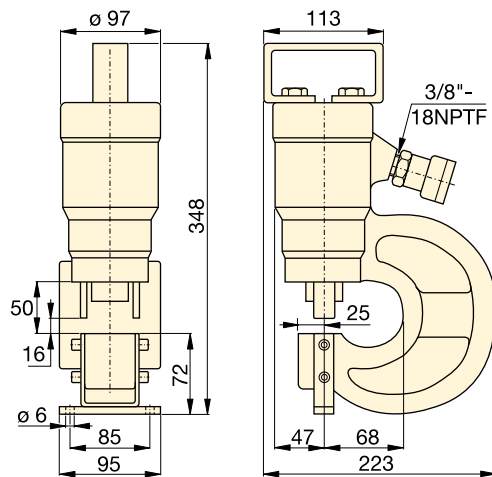

MSP SP STP Series



Capacity:

35 ton

Hole Sizes:

7,9 - 20,6 mm

Maximum Operating Pressure:

700 bar



CAUTION!

The chart below is for reference only! Maximum allowable material thickness to be punched varies with set wear.



CAUTION!

Material thickness should not exceed hole diameter.

Steel Qualities (see table):

- 1) Mild A-7
- 2) Boiler Plate
- 3) Structural A-36
- 4) Struct Corten (ASTM A242)
- 5) Cold Rolled C-1018
- 6) Hot Rolled C-1050
- 7) Hot Rolled C-1095
- 8) Hot Rolled C-1095 Annealed
- 9) Stainless Annealed
- 10) Stainless 304 Hot Rolled
- 11) Stainless 316 Cold Rolled

Model Nr. Standard Punch & Die Set	Maximum allowable material thickness to be punched (mm) Material thickness should not exceed hole diameter										
	1)	2)	3)	4)	5)	6)	7)	8)	9)	10)	11)
 SPD313	7,9	7,9	6,4	6,4	6,4	6,4	3,3	4,8	6,4	6,4	6,4
SPD375	9,7	9,7	7,9	7,9	7,9	7,9	4,8	6,4	7,9	7,9	7,9
SPD438	11,2	11,2	9,7	9,7	9,7	7,9	4,8	7,9	7,9	7,9	7,9
SPD531	12,7	12,7	11,2	11,2	11,2	9,7	6,4	7,9	9,7	9,7	9,7
SPD563	12,7	12,7	12,7	11,2	12,7	11,2	6,4	9,7	11,2	11,2	11,2
SPD688	12,7	12,7	12,7	11,2	12,7	10,2	6,4	7,9	10,2	10,2	10,2
SPD781	12,7	12,7	12,7	11,2	12,7	9,7	6,4	7,9	9,7	9,9	9,7
SPD813	12,7	12,7	12,7	11,2	12,7	7,9	4,8	7,9	7,9	7,9	7,9
SPD458	7,9	7,9	6,4	6,4	6,4	6,4	3,3	4,8	6,4	6,4	6,4
SPD549	9,7	9,7	7,9	7,9	7,9	7,9	4,8	6,4	7,9	7,9	7,9
SPD639	11,2	11,2	9,7	9,7	9,7	7,9	4,8	7,9	7,9	7,9	7,9
SPD728	12,7	12,7	11,2	11,2	11,2	9,7	6,4	7,9	9,7	9,7	8,6
SPD106	7,9	7,9	6,4	6,4	6,4	6,4	3,3	4,8	6,4	6,4	6,4
SPD125	9,7	9,7	7,9	7,9	7,9	7,9	4,8	6,4	7,9	7,9	7,9
SPD188	11,2	11,2	9,7	9,7	9,7	7,9	4,8	7,9	7,9	7,9	7,9
SPD250	12,7	12,7	11,2	11,2	11,2	9,7	6,4	7,9	9,7	9,7	9,7

▼ The hydraulic punch cuts the time spent forming holes.



▼ Shown: SP50100



- Available as a complete set including electric pump and hoses
- Double-acting cylinder design for fast cycle times
- Punch and die changeover tools included
- Lifting bracket included
- Adjustable power stripper prevents movement of the metal during stripping
- CR400 female couplers included.

Cuts the Time Spent Forming Holes



Depth Stop

For simplified repetitive punching applications an adjustable Depth Stop is available. Order model number: **SP110**.



Foot Mounting Kit

A foot mounting kit for easy mounting of the 50 ton punch to workbench or fixture is available. Order model number: **SP120**.



Ordering Information

The 50-ton Hydraulic Punch may be ordered by itself or as a set with an electric pump. A punch and die may be ordered as a matched set.

Please refer to the selection chart information.



◀ Save time using the 50-ton Enerpac Punch.

▼ Shown below is the 50 ton punch with SP120 and SP110 assembled.



50 Ton Double-Acting Hydraulic Punch

▼ QUICK SELECTION CHART PUNCH SETS

Included				Set Model Number	 (kg)
Model Number Punch *	Punch & Die Sets	Electric Pump	Hydraulic Hose (2x)		
SP50	All **	-	-	SP50100	116
SP50	All **	ZE4410SE	HC7206	SP5000E	174

* Punch Oil Capacity:

Advance: 278 cm³

Retract: 229 cm³

** All standard sets from chart below.

SP Series



Capacity:

50 ton (490 kN)

Hole Sizes:

13,5 - 26,2 mm

Maximum Operating Pressure:

700 bar

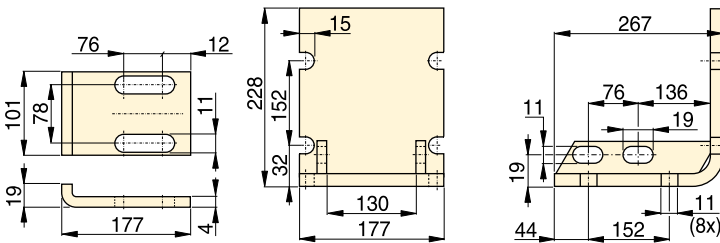

SP110

SP120

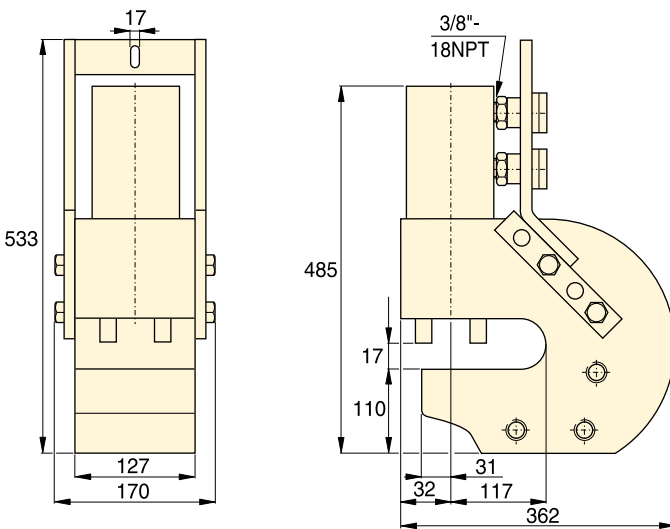

SP50



CAUTION!

Material thickness should not exceed hole diameter.



CAUTION!

Chart below is for reference only! Maximum allowable material thickness to be punched varies with set wear.

Steel Qualities (see table below):

- 1) Mild A-7
- 2) Boiler Plate
- 3) Structural A-36
- 4) Struct Corten (ASTM A242)
- 5) Cold Rolled C-1018
- 6) Hot Rolled C-1050
- 7) Hot Rolled C-1095
- 8) Hot Rolled C-1095 Annealed
- 9) Stainless Annealed
- 10) Stainless 304 Hot Rolled
- 11) Stainless 316 Cold Rolled

▼ STANDARD PUNCH AND DIE SELECTION CHART

Hole Shape	Hole Size (mm)	Bolt Size (mm)	Model Numbers Standard Punch and Die Set 	Maximum Allowable Material Thickness To Be Punched (mm)										
				1)	2)	3)	4)	5)	6)	7)	8)	9)	10)	11)
●	13,5	M12	SP150	13,5	13,5	13,5	13,5	13,5	12,4	8,1	10,2	12,4	12,4	12,4
●	16,7	M16	SP170	-	-	-	-	-	13,0	8,1	10,2	13,0	13,0	13,0
●	19,8	M18	SP190	-	-	-	-	-	12,4	8,1	10,2	12,4	12,7	12,4
●	23,1	M20	SP121	14,2	14,2	14,2	12,7	14,2	8,9	5,6	8,9	8,9	8,9	8,9
●	26,2	M24	SP123	14,2	14,2	14,2	11,2	14,2	7,9	4,8	7,9	7,9	7,9	7,9

LW-Series, Hydraulic Vertical Lifting Wedges

ENERPAC

▼ Shown: LWC16, LW16 with SB2 and optional LWB1



- Integrated hand pump offers greater maneuverability (LWC16 only)
- Minimized access gap for greater accessibility on applications with limited insertion space
- Secure, stable lifting and lowering motion with no slippage
- Single-acting spring return cylinder allows for automatic, mechanical retraction
- Includes safety block SB2
- LW16 can be used in multiple set-up.

LW Series

Maximum Lifting Force:

16 ton (157 kN)

Minimum Clearance:

10 mm

Maximum Lift Height*:

51 - 69 mm

Maximum Operating Pressure:

700 bar

* Using Stepped Block LWB1



Power Box

Tool box with hand pump, gauge adaptor assembly, hose and LW16.

Page: 65



Control Manifolds

Control Manifold to control two or four LW16 lifting wedges simultaneously.

AM21 with 3 ports 3/8" NPTF
AM41 with 5 ports 3/8" NPTF.

Page: 132

▼ For lifting heavy equipment with minimum floor clearance the LW16 is the ideal tool.

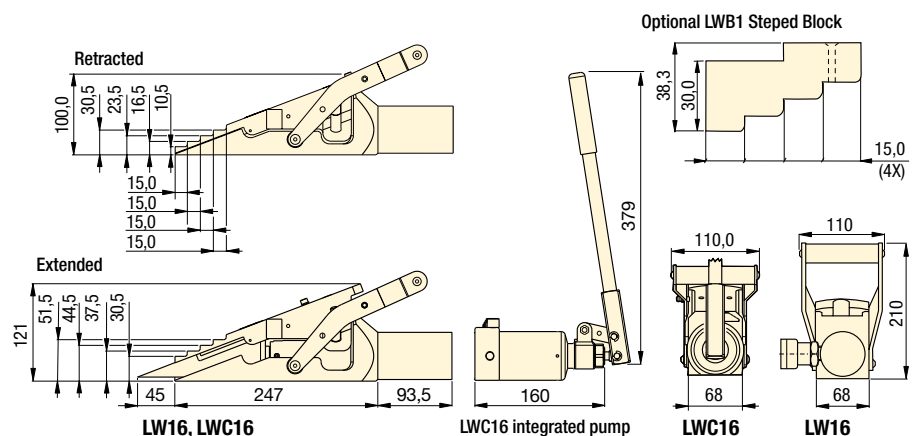

Max. Lifting Force	Model Number	Minimum Clearance Gap	Max. Lift per Stage	Max. Lifting Height	Max. Lifting Height using Stepped Block LWB1	Oil Capacity	Pump Power Source	(kg)
ton (kN)		(mm)	(mm)	(mm)	(mm)	(cm ³)		
16 (157)	LW16 ¹⁾	10	21	51,5	69	78	External	7,0
	LWC16 ²⁾					–	Integrated	10,0

¹⁾ Includes SB2

²⁾ Includes SB2, LWB1, and carrying case.

▼ SOH10-6 Hydraulic Machine Lifts



- For lifting heavy equipment with minimum available access
- Remote hydraulic pump enhances safety
- Low-height lifting toe
- Precision guided to reduce friction and isolate cylinder from side-loads
- Two extendable support feet provide extra stability
- Includes RC-Series cylinder with CR400 coupler.

SOH Series

Lifting Capacity:
8,5 - 20 ton

Stroke:
136 - 157 mm

Toe Clearance:
20 mm

Maximum Operating Pressure:
700 bar



RSM-Series, Low-Height Cylinders

Low-height, single-acting spring-return cylinders are ideal for space restricted applications.

Page: 26



Machine Skates

In combination with the Enerpac Machine Lifts we recommend Machine Skates for moving heavy loads.

Page: 190

▼ Limited access under this machine makes the Enerpac hydraulic machine lift the perfect solution.

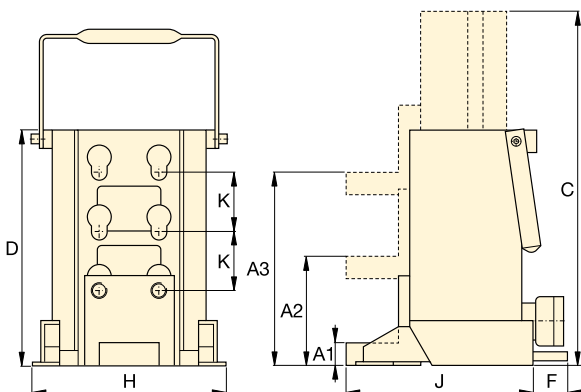

Capacity	Toe Clearance (mm)			Stroke	Model Number	Oil Capacity	Dimensions (mm)						🏋️ (kg)
	Minimum A1	Central A2	Maximum A3				Total Ext. Height C	Total Body Height D	F	H	J	K	
8,5 (75)	20	95	169	136	SOH10-6	224	430	294	-	190	214	74	26
20 (178)	30	110	190	157	SOH23-6	525	472	320	65	265	250	80	45

▼ **MLS-Series, Wheeled Machine Skates**



DESIGNED FOR INDUSTRIAL MACHINE MOVERS AND MILLWRIGHTS

- Durable polyurethane or optional nylon wheels provide excellent stability while preventing damage to finished floors
- Rugged, reliable bearings and wheels deliver low rolling resistance
- Low height requires minimal lifting to accommodate moves
- MLSF steerable skates improve maneuverability with turntables that can easily rotate under the load, ideal for general applications
- For ultimate versatility, MLSR rotational skates provide 360 degrees of directional movement, ideal for confined space applications
- Models pre-assembled with nylon wheels are available upon request
- Configure MLSR sets with a handle and connecting bar to meet your application requirements.

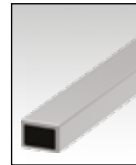

Connecting Bars

Connecting bars come standard with MLSD-models. Different lengths of connecting bars are available to connect MLSR-models together.

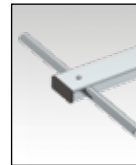

Handles

MLSF-models come standard with size-specific handles. Optional manual or pulling eye handles are available for MLSR-models.



Optional Turntable Assembly

Available for MLSR-Rotational Skates. The turntable provides an additional 37 mm of height.

Model Number	Type	Compatible with
MLSRTT	Swivel Top	MLSR3, MLSR7, MLSR9



Nylon Wheel Kits

Nylon wheel kits are available for better wear resistance or if increased capacity is required.

Nylon Wheel Kit	Part Number	Compatible Skates	No. of Wheel Kits per Skate
ø85mm x 87mm width. Includes 4 wheels	MLSWNY85874	MLSF3, MLS3	1
		MLSF7, MLS7	2
		MLSF10, MLS10	3
		MLSF13, MLS13	4
ø140mm x 85mm width. Includes 4 wheels	MLSWNY140854	MLSF17, MLS17	2
		MLSF27, MLS27	3
		MLSF35, MLS35	4

An Enerpac MLS-Series machine skate set combined with a low-height hydraulic cylinder provides the ideal package for heavy machinery moves. ▶



Wheeled Machine Skates



Selecting the Right Skate Set

MLS-Series Machine Skates offer easy and stable movement across various floor types.

MLSS-sets (consisting of MLSF and MLSD-skates) are a great option for most maneuvers, especially when confined space is not a concern.

MLSR-rotational skates have the highest level of maneuverability for easy moves in tight spaces and around corners.

Combining MLSR-models with connecting bars and handles provides a versatile set to cover more applications.

For ordinary concrete floors consider the ER-Series Chain Roller Machine Skates.

EMLS, EMV-Series, Battery-Powered Machine Skates

Remote-controlled, heavy-duty machine moving system up to 50 ton for clean and even surfaces.

MLS Series



Capacity (Individual Skates):

3 - 32 ton (29 - 314 kN)

Height:

110 - 180 mm

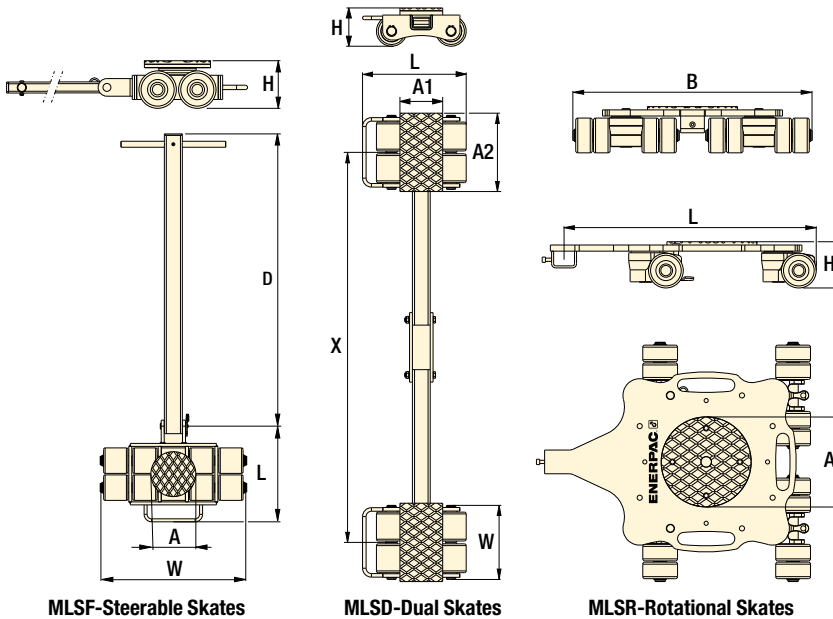

MLSF-Steerable Skates

MLSD-Dual Skates

MLSR-Rotational Skates

SELECTION CHART

Capacity ton (kN)	Model Number	No. of Wheels/ Diameter	Dimensions (mm)									Handle Type	Weight (kg)
			ø mm	A	A1	A2	B	D	H	L	W		
3 (29)	MLSF3	4 85	150	-	-	-	1000	110	238	268	-	Manual	14
6 (59)	MLSF7	8 85	150	-	-	-	1000	110	339	483	-	Manual	26
9 (88)	MLSF10	12 85	170	-	-	-	1170	110	525	780	-	Towable	57
12 (118)	MLSF13	16 85	170	-	-	-	1170	110	528	982	-	Towable	68
16 (157)	MLSF17	8 140	220	-	-	-	1620	180	567	724	-	Towable	132
24 (235)	MLSF27	12 140	220	-	-	-	1620	180	567	931	-	Towable	158
32 (314)	MLSF35	16 140	250	-	-	-	1620	180	567	1142	-	Towable	196
3 (29)	MLSD3	4 85	-	150	75	-	-	110	246	120	120-1000	-	14
6 (59)	MLSD7	8 85	-	120	220	-	-	110	291	220	420-1100	-	29
9 (88)	MLSD10	12 85	-	170	180	-	-	110	295	295	460-1145	-	36
12 (118)	MLSD13	16 85	-	200	220	-	-	110	291	382	560-1095	-	45
16 (157)	MLSD17	8 140	-	318	190	-	-	180	456	216	220-1940	-	92
24 (235)	MLSD27	12 140	-	318	285	-	-	180	456	313	320-1940	-	119
32 (314)	MLSD35	16 140	-	318	382	-	-	180	456	410	420-1660	-	152
3 (29)	MLSR3	8 85	170	-	-	467	-	110	588	-	-	-	35
6 (59)	MLSR7	16 85	220	-	-	585	-	110	650	-	-	-	43
8 (78)	MLSR9	20 85	220	-	-	786	-	110	829	-	-	-	59



Lifting Wedges & Machine Lifts

To place Machine Skates, the load must first be lifted. This can be done using the LW-Series Enerpac Lifting Wedge or SOH-Series Machine Lifts.

Page: 179



ER-Series, Chain Roller Skates

Enerpac has an alternative offering of steel chain roller style machine skates for moving loads up to 80 ton.

Page: 192

MLSR ACCESSORIES

Description	Model Number	Type	Length (mm)	Compatible with
Handles	MLSHRT	Manual	990	MLSR3
	MLSHRR	Towable	1170	
Connecting Bars	MLSCR6	Rigid	2000	MLSR7
	MLSCR8	Rigid	2500	MLSR9
	MLSCRH8	Handle Joint	2500	

AVAILABLE SETS

Set Model Number	Set Model Numbers Include:	Set Capacity * ton (kN)
MLSS7	1x MLSF3 + 1x MLSD3	6 (59)
MLSS13	1x MLSF7 + 1x MLSD7	12 (118)
MLSS20	1x MLSF10 + 1x MLSD10	18 (176)
MLSS27	1x MLSF13 + 1x MLSD13	24 (235)
MLSS35	1x MLSF17 + 1x MLSD17	32 (314)
MLSS53	1x MLSF27 + 1x MLSD27	48 (471)
MLSS70	1x MLSF35 + 1x MLSD35	64 (628)

* Set capacity assumed to be equally distributed across skates. Ensure each individual skate capacity is not exceeded.

▼ Shown: Set ERS20

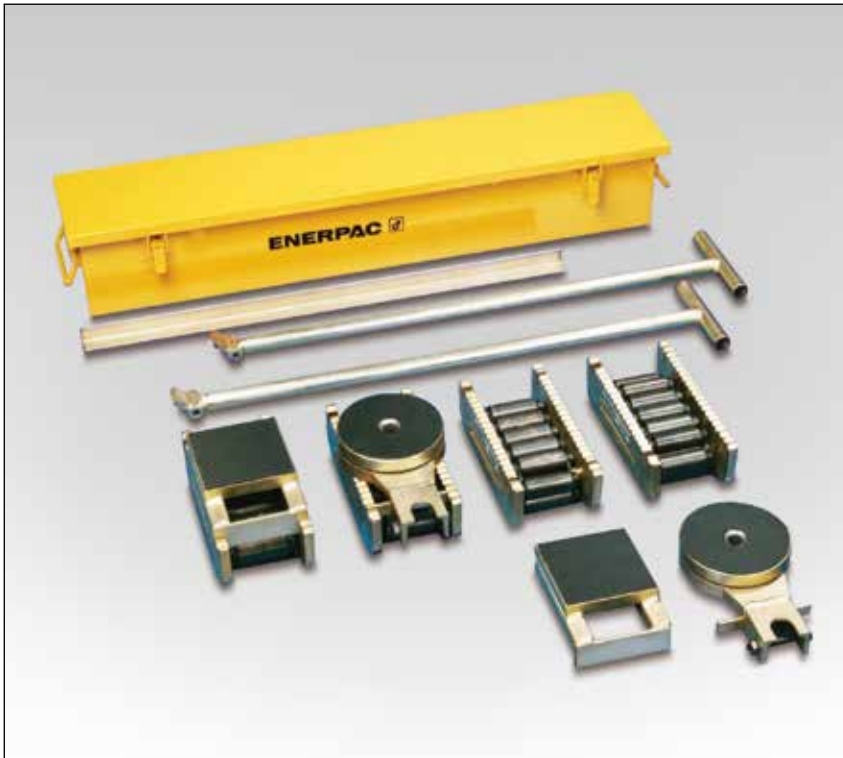

- Rugged and sturdy construction for long life
- Low profile construction for increased stability
- Low rolling-resistance allows for easy transportation
- Attachable load leveling plates and swivel turntables for turning corners.

Move Heavy Loads Easily and Safely



Sets (see table) include all components necessary to handle a variety of applications.

Two **ELB1** link-up bars, two **ERH1** handles (875 mm long) and one **EMB1** metal box are included.

Optional long handle **ERH2** (1180 mm) available for 60 and 80 ton only.



Lifting Wedges and Machine Lifts

To place the Machine Skates, the load must first be lifted. This can be done easily and safely using the Enerpac Lifting Wedge or Machine Lifts.

Page: 188



MLS-Series, Polyurethane Wheeled Machine Skates

Enerpac has an alternative offering of machine skates upto 32 ton capacity. Durable polyurethane or optional nylon wheels provide excellent stability while preventing damage to finished floors

Page: 190

▼ Heavy transport using Machine Skates. The machine is first lifted, using SOH-Series Enerpac Machine Lifts.



▼ Chemical tank transportation: The first few centimetres the load was lifted with RCS-Series low height cylinders and then moved on to machine skates for transportation.



Heavy Duty Chain Roller Machine Skates

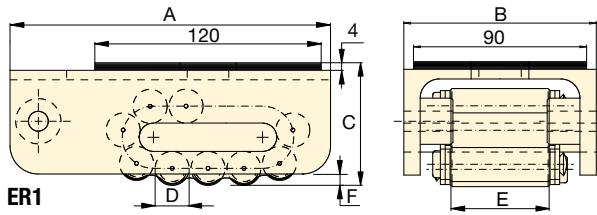

ER1

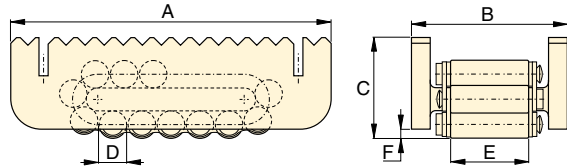

ER10, ER15, ER30

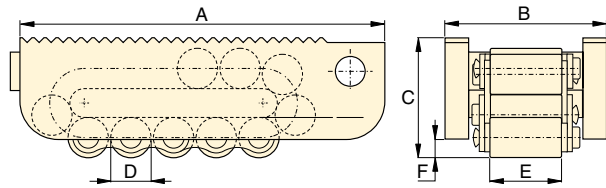

ER60, ER80

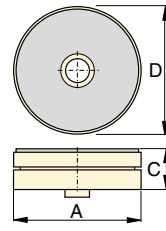

ES1, Turntable Swivel

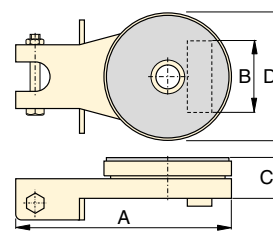

ES10, ES15, ES30 Turntable Swivel

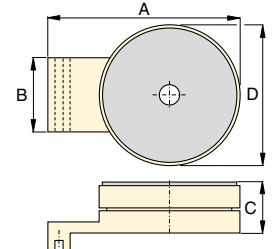



ES60, ES80, Turntable Swivel

**EL
ER
ES
Series**



Maximum Carrying Capacity:
80 ton (711 kN)

Machine Skates may be ordered separately or as a matched set.

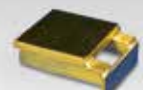
Set Capacity * ton (kN)	Set Model Number	Machine Skates (4x)	Turntable Swivels (2x)	Leveling Plates (2x)	Weight including handles and metal box (kg)
					
20 (178)	ERS20	ER10	ES10	ELP10	49
30 (267)	ERS30	ER15	ES15	ELP15	55
60 (533)	ERS60	ER30	ES30	ELP30	75

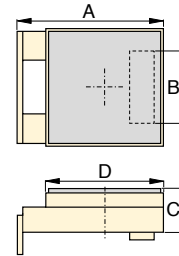

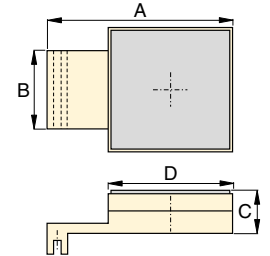

ELP10, ELP15, ELP30
Leveling Plate



ELP60, ELP80
Leveling Plate

* Sets are designed to enable two skates to take full load for extra safety on uneven floor surfaces

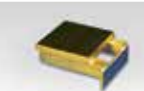
	Capacity ton (kN)	Model Number	Dimensions (mm)						Contact Rolls per Skate	Rollers per Skate	 (kg)
			A	B	C	D	E	F			
	1 (8,9)	ER1	170	100	65	18	51	6	4	11	3,8
	10 (89)	ER10	210	102	66	18	51	6	5	15	5,2
	15 (133)	ER15	220	115	75	24	60	10	4	13	7,3
	30 (267)	ER30	270	130	92	30	68	10	4	13	13,0
	60 (533)	ER60	380	168	125	42	76	16	4	13	31,9
	1 (8,9)	ES1	207	-	26	90	-	-	-	-	1,1
	10 (89)	ES10	220	73	42	130	-	-	-	-	3,7
	15 (133)	ES15	220	86	42	130	-	-	-	-	3,7
	30 (267)	ES30	250	96	48	150	-	-	-	-	5,3
	60 (533)	ES60	275	114	61	190	-	-	-	-	13,7
	10 (89)	ELP10	149	73	42	120	-	-	-	-	3,7
	15 (133)	ELP15	149	86	42	120	-	-	-	-	3,7
	30 (267)	ELP30	178	96	48	130	-	-	-	-	5,3
	60 (533)	ELP60	270	114	61	180	-	-	-	-	13,8
	80 (711)	ELP80	350	128	61	200	-	-	-	-	18,8

▼ CM16



- Protect your equipment from dust, water, grease and dirt
- Reduce losses on the jobsite, maintenance area or shop
- Durable steel, painted with rust-resistant primer and finished in durable enamel
- Heavy duty hinges and lifting handles
- Lockable.

▼ When not storing the lifting system, this heavy-duty storage case doubles as a work station.



CM Series

Case Size:

19 - 453 litres

Protect your Equipment



Maintenance Sets

Enerpac Maintenance sets are a complete assortment of hydraulic powered tools.

Using these sets allows you to quickly configure a unique tool to meet your most difficult jobs.

Built around the Enerpac lightweight hand pump, hose and cylinder, these sets enable you to push, pull, lift, press, straighten, spread and clamp with forces up to 12,5 ton.

Page: 180



Hydraulic Pullers

These hydraulic pullers eliminate time-consuming and unsafe hammering, heating or prying.

Damage to parts is minimized through the use of controlled hydraulic power.

Page: 159

Case Size (litres)	Model Number	Inside Dimensions L x W x H (mm)	Thickness (mm)	 (kg)
19	CM6	597 x 178 x 203	0,9	7
32	CM1	622 x 282 x 165	0,9	8
127	CM4	778 x 454 x 354	1,5	16
212	CM7	1210 x 387 x 457	1,9	57
453	CM16	1216 x 606 x 557	1,5	55

Hydraulic Wedgie and Spread Cylinders

▼ Shown clockwise from top: **WR15, WR5, A92**



- **WR5:** For use in very confined work areas
- **WR15:** For long stroke spreading applications
- **Single-acting, spring return**
- **A92:** Spreader attachment; threads on 10 ton RC-Series cylinders * (except RC101).

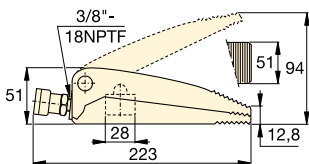

WR5

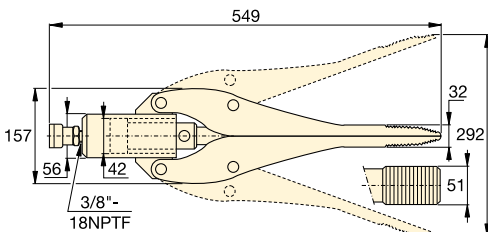

WR15

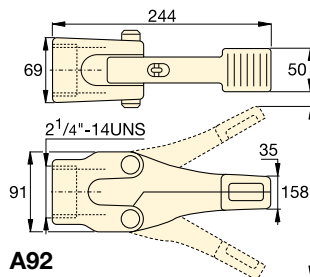

A92

Cylinder Capacity	Tip Clearance	Model Number	Maximum Spread	Cylinder Effective Area	Oil Capacity	
ton (kN)	(mm)		(mm)	(cm ²)	(cm ³)	(kg)
1,0 (8,9)	12,8	WR5	94	6,5	10	2,3
0,75 (6)	32,0	WR15	292	14,5	64	11,3
1,0 (8,9)	35,0	A92 *	158	–	–	3,6

* Maximum system pressure must be limited to half the rated pressure (350 bar).

A WR Series



Capacity:

0,75 - 1,0 ton

Tip Clearance:

12,8 - 35 mm

Maximum Spread:

94 - 292 mm

Maximum Operating Pressure:

700 bar



RC-Series Cylinders

10 ton RC-Series cylinders (except RC-101) fit into **A92** Spreader Attachment.

Page: **6**



Power Box

Tool box with **P392** hand pump, gauge adaptor assembly, hose and **WR5**.

Page: **65**



Best Match Hand Pump

To power your **WR5** and **WR15** the **P392** hand pump is an ideal choice. Use Enerpac **H700-Series** hose (page 128) for hydraulic connection.

Page: **76**

▼ A **WR5** wedgie cylinder is used to loosen a bridge bearing.

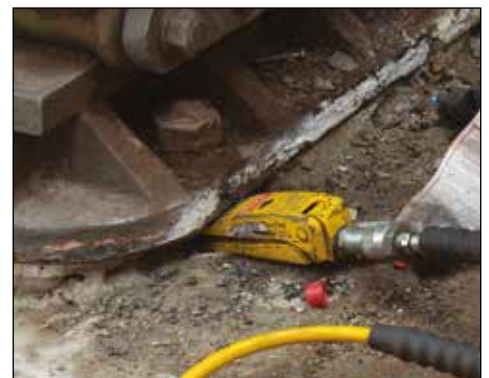

▼ Shown: STB101H



Quick, Safe and Wrinkle-free Bending



'One Shot' and 'Sweep'

One shot shoes give up to a 90° bend without resetting.





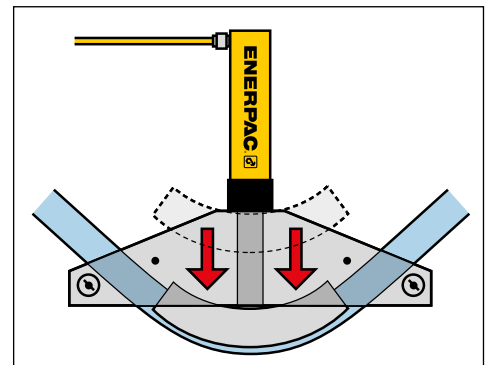



Sweep shoes are used where increasing radii are required for multiple parallel pipe installations.

- Makes smooth, wrinkle-free bends
- Sets include genuine Enerpac cylinder, hose, air, electric or hand pump
- Sets are also available without hydraulics
- Bending shoes and frame are lightweight, heat-treated aluminium
- All sets include sturdy steel storage case
- All sets include BZ12091 angle indicator for accurate bending
- BZ12377 Shoe Lock Pin included in every set
- Eject-O-Matic™ benders (STB202 models) have double-acting cylinder to eject pipe from the bending shoe.



▲ Typical one shot bending operation.

▼ SELECTION CHART

Pipe Range Nominal Size (inch)		Bender Set Model Number	Hand Pump *	Air Pump *	Electric Pump *		Cylinder *	Hose *	Saddle *	 (kg)
One Shot	Sweep									
1/2 - 2	-	STB101X	-	-	-	-	-	-	A12	40
		STB101N	-	-	-	-	RC1010	HC7206	A12	48
		STB101H	P392	-	-	-	RC1010	HC7206	A12	52
		STB101A	-	PATG1102N	-	-	RC1010	HC7206	A12	54
		STB101E ²⁾	-	-	PUJ1200E ²⁾	-	RC1010	HC7206	A12	57
1 - 2	2 1/2 - 4	STB221X	-	-	-	-	-	-	A29	104
		STB221N	-	-	-	-	RC2510	HC7206	A29	119
		STB221H	P80	-	-	-	RC2510	HC7206	A29	130
1 1/4 - 4	-	STB202X ¹⁾	-	-	-	-	-	-	A29	143
		STB202N ¹⁾	-	-	-	-	RR3014	HC7206 (2x)	A29	174
		STB202E ^{1) 2)}	-	-	-	ZU4408SE ²⁾	RR3014	HC7206 (2x)	A29	212

* See corresponding sections in this catalog for more detailed specifications.

¹⁾ Eject-O-Matic™

²⁾ For 115 volt applications replace the last digit of Set Model Number and pump from 'E' to 'B'. Example: **STB202B**

Pipe Bender Sets

Nominal Pipe Size (inch)	Wall Thickness (mm)	Schedule Pipe *	Pipe Bend Inside Radius (inch)	STB101	STB221 ø 1 - 2" One Shot	STB202	One Shot Bending Shoe Model Number	Sweep Bending Shoe Model Number
				ø ½ - 2" One Shot	ø 2¼ - 4" Sweep	ø 1¼ - 4" One Shot		
½	2,8	40	27/8	Yes	-	-	BZ12011	-
	3,7	80		Yes	-	-		
	4,7	160		WS *	-	-		
	7,5	DEH		WS *	-	-		
¾	2,9	40	4	Yes	-	-	BZ12021	-
	3,9	80		Yes	-	-		
	5,5	160		WS *	-	-		
	7,8	DEH		WS *	-	-		
1	3,4	40	57/8	Yes	Yes	-	BZ12031	-
	4,5	80		Yes	Yes	-		
	6,4	160		WS *	WS *	-		
	9,1	DEH		-	WS *	-		
1¼	3,6	40	67/16	Yes	Yes	Yes	BZ12041	-
	4,9	80		Yes	Yes	Yes		
	6,4	160		WS *	WS *	Yes		
	8,7	DEH		-	WS *	WS *		
1½	3,7	40	7 5/16	Yes	Yes	Yes	BZ12051	-
	5,1	80		Yes	Yes	Yes		
	7,1	160		WS *	WS *	Yes		
	10,2	DEH		-	WS *	WS *		
2	3,9	40	8 5/16	-	Yes	Yes	BZ12061	-
	5,5	80		-	Yes	Yes		
	8,7	160		-	WS *	Yes		
2½	5,2	40	9½	-	Yes	Yes	BZ12341	BZ12382
	7,0	80		-	WS *	Yes		
	9,5	160		-	WS *	Yes		
3	5,5	40	11¼	-	Yes	Yes	BZ12351	BZ12383
	7,6	80		-	WS *	Yes		
3½	5,7	40	15½	-	Yes	Yes	BZ12391	BZ12384
	8,1	80		-	WS *	Yes		
4	6,0	40	17¾	-	Yes	Yes	BZ12392	BZ12385
	8,6	80		-	-	Yes		

STB Series



Nominal Pipe Size:

ø ½ - 4 inch

Maximum Bending:

90°

Maximum Operating Pressure:

700 bar



* Schedule Pipe

All bender sets are designed to bend mild steel pipe. For other material please consult Enerpac.

40 = Standard;

80 = Extra Heavy;

160 = Double Extra Heavy;

DEH = Double Extra Heavy (slightly thicker than 160);

WS = Can be bent using wider spacing for swivel shoes.

Frame Assembly	Pivot Pins (2x)	Pivot Shoes (2x)	Bending Shoes included (Shoes with ³⁾ are Sweep, all other shoes are One Shot)									Bender Set Model Number
			STB101	STB221	STB202	One Shot	Sweep	One Shot	Sweep	One Shot	Sweep	
BZ12371	BZ12375	BZ12071	BZ12011	BZ12021	BZ12031	BZ12041	BZ12051	BZ12061	-	-	STB101X	
			BZ12011	BZ12021	BZ12031	BZ12041	BZ12051	BZ12061	-	-	STB101N	
			BZ12011	BZ12021	BZ12031	BZ12041	BZ12051	BZ12061	-	-	STB101H	
			BZ12011	BZ12021	BZ12031	BZ12041	BZ12051	BZ12061	-	-	STB101A	
			BZ12011	BZ12021	BZ12031	BZ12041	BZ12051	BZ12061	-	-	STB101E ²⁾	
BZ12372	BZ12376	BZ13401	BZ12031	BZ12041	BZ12051	BZ12061	BZ12382 ³⁾	BZ12383 ³⁾	BZ12384 ³⁾	BZ12385 ³⁾	STB221X	
			BZ12031	BZ12041	BZ12051	BZ12061	BZ12382 ³⁾	BZ12383 ³⁾	BZ12384 ³⁾	BZ12385 ³⁾	STB221N	
			BZ12031	BZ12041	BZ12051	BZ12061	BZ12382 ³⁾	BZ12383 ³⁾	BZ12384 ³⁾	BZ12385 ³⁾	STB221H	
BZ12374	BZ12376	BZ13401	BZ12041	BZ12051	BZ12061	BZ12341	BZ12351	BZ12391	BZ12392	STB202X ¹⁾		
			BZ12041	BZ12051	BZ12061	BZ12341	BZ12351	BZ12391	BZ12392	STB202N ¹⁾		
			BZ12041	BZ12051	BZ12061	BZ12341	BZ12351	BZ12391	BZ12392	STB202E ^{1) 2)}		

▼ RP70A, Hydraulic Rail Stressor



Hydraulic Rail Stressor

- Modular 70 ton stressor and holds the rail in neutral length during the welding process
- Easy to assemble in less than 2 minutes
- The RP70A stressor can be safely transported in a special designed steel transport frame together with pump and hose set
- Certified lifting eyes mounted directly on the clamps for easy and safe lifting
- Designed with new aluminum lightweight cylinders including protection sleeves over the rods to extend durability

ZC3-Series, Battery Powered Stressing Pumps *(see page 199)*

- Zero emission hydraulic power pack
- Advanced brushless motor and Lithium-ion battery
- Steel manual operating valve with pressure hold function
- Safety key to safely leave the pump unattended during breaks
- Pressure release valve V182 included.



Lightweight & Modular Rail Stressing System



RP70A Rail Stressor

The Enerpac RP70A is a lightweight rail stressing kit for railway maintenance crews who assemble and install the rail puller directly on site.

The durable, easy-to-assemble components, stored and protected in a specially designed steel cage during transport, are up to 3 times lighter than similar tools.

The less physically demanding Enerpac RP70A is compatible with the cordless Enerpac ZC3-Series pump for a complete clean energy solution.



Certificate of Acceptance PA05-06958

Both RP70A Hydraulic Rail Stressor and ZC3 Stressing Pump are certified by Network Rail.



Durability

Double-acting aluminium cylinders are enclosed within steel sleeves protecting the cylinder rods from damage, particularly weld splatter and extends the life of the unit.



▲ RP70A rail stressor can be safely transported by forklift truck or manually in a special designed steel transport frame.

◀ Complete system with RP70A Hydraulic Rail Stressor and ZC3 cordless stressing pump.

Hydraulic Rail Stressor & Cordless Powerpack



RP70A Rail Stressor

The RP70A Hydraulic Rail Stressor is used to pull together heavy railroad tracks for stressing and thermite welding.

In the rail industry ergonomic managers specify that tools over 29 kg should be modular and be able to be manually assembled/transported on site.

The RP70A can be used with the battery powered pump and optional transportation and storage frame for easy mobilisation/demobilisation. The stressor is interchangeable with other type of powerpacks. The RP70A adjusts the gap between rail ends for rail stressing, rail welding, repairing rail failures and servicing insulators.

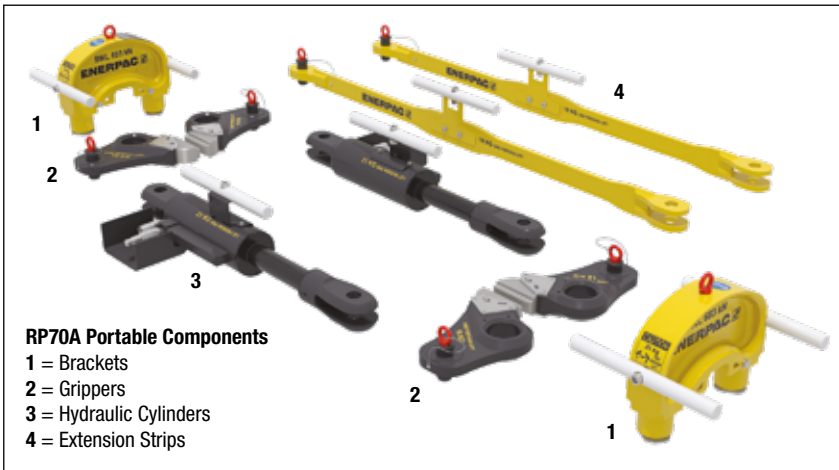

▲ Modular 70 ton stressor and holds the rail in neutral length during the welding process.



▲ Storage and transport frame RP70ATF together with stressor, pump and possibility to safely store the hose set in a lockable storage space under the frame.

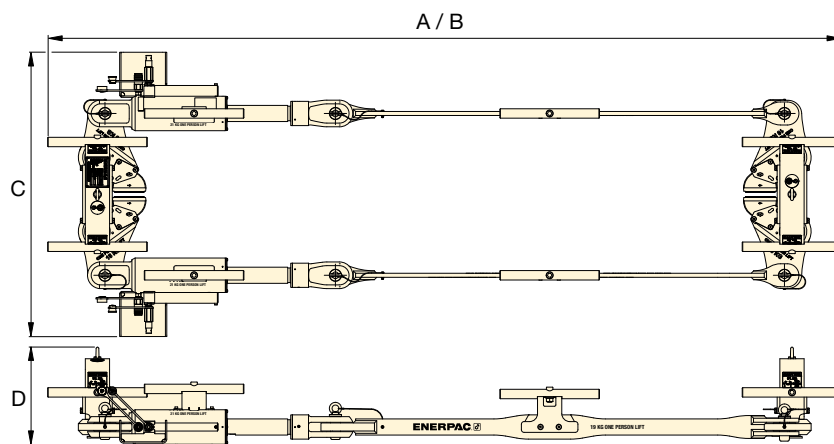

Capacity ton (kN)		Stroke (mm)	Model Number	Dimensions (mm)				Weight (kg)
Pull	Push			A	B	C	D	
70 (683)	35 (440)	205	RP70A	2950	3155	1056	361	205

A = Closed length.
 B = Extended length

RP Series



Rated Pulling/Pushing Capacity:

70 / 35 ton

Stroke:

205 mm

Maximum Operating Pressure:

580 bar



Hydraulic Hoses

Use Enerpac hose model number H9210-RS 3,0 metres hydraulic hoses to ensure the integrity of your Rail Stressor system.



Battery Powered Stressing Pumps

- Cordless, zero emission pump
- 82V 4Ah Lithium-ion battery
- Roll cage and pressure gauge
- 3-stage: 0,52 l/min at 580 bar
- 4,0 litres useable oil capacity
- Pump weight 34,8 kg (excluding battery)
- Reduced Noise Level 80 dBA max
- Advanced brushless 1,0 kW motor.

Model Number	Battery Charger (Volts)	Maximum Pressure (bar)
ZC3404JE-RS	230	700
ZC3404JB-RS	115	700

World-Class Cutters

When you need to make cuts through heavy-duty bar, chain, cable and similar materials, look no further than Enerpac's broad range of cutters.

An extensive line-up of hydraulic, electric and manual cutters provides a quick, safe and cost-effective solution for technicians from construction, mining, manufacturing and many other industries.

Enerpac's cutters are built to handle industrial-grade materials on a daily basis. Like all Enerpac tools, each cutter is designed and built to last in tough working conditions for a safer, simpler and more productive workflow.

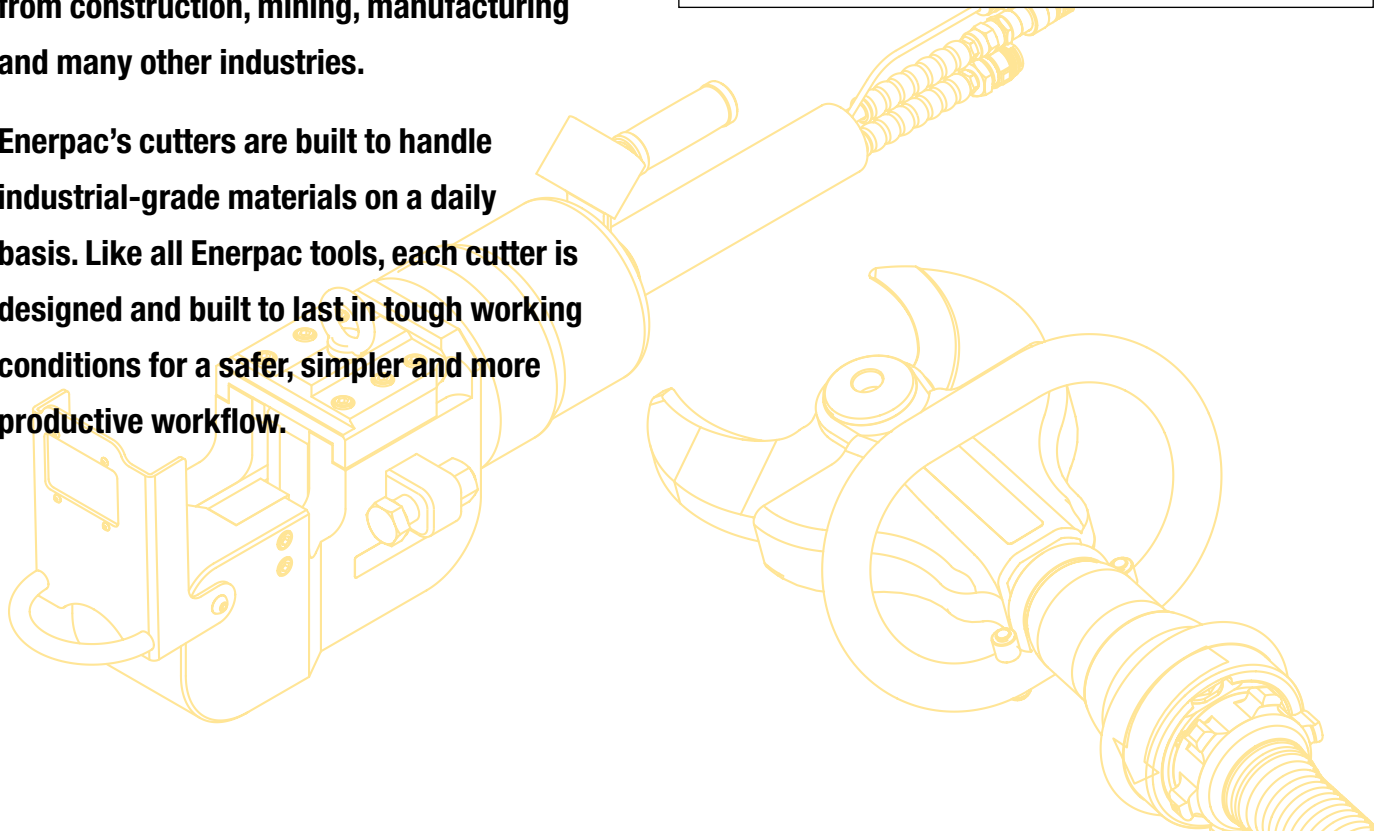

Cutter Type		Maximum Tool Capacity *	Series		Power Source	Page
Bar Cutters		52 mm (max. material cutting diameter)	EBH EBE EBC		Hydraulic, Electric & Cordless	202 ▶
Decommissioning Cutters		170 mm (max. blade aperture)	EDCH		Hydraulic	206 ▶
Flat Bar Cutters		70 x 15 mm (max. material cutting Height x Width)	EFBE		Electric	207 ▶
Chain Cutters		32 mm (max. link cutting diameter)	ECCE		Electric	208 ▶
Wire Rope and Cable Cutters		180 mm (max. material cutting diameter)	EWCH EWCE		Hydraulic & Electric	210 ▶
Cutter / Spreader Combination Tools		300 mm (max. blade aperture)	ECSE		Electric	213 ▶
Hydraulic Cutterheads		101 mm (max. material cutting diameter)	WHC WHR STC		Hydraulic	214 ▶
Self-Contained Hydraulic Cutters		85 mm (max. material cutting diameter)	WMC		Manual	215 ▶
ZE-Series Pumps and Accessories		1,1 - 5,6 kW	EBH EWCH		Electric	216 ▶
ZC, ZE-Series Pumps and Accessories		1,0 - 1,1 - 5,6 kW	EDCH		Cordless & Electric	217 ▶

* Actual cutting capacities may vary depending on material being cut.

▼ Shown from left to right: EBC20E, EBH30 and EBE22E



Your Fast, Safe and Simple Solution for Cutting Metal Bar



Internal Mechanics

EBH-Series: Cylinder is driven by an external Enerpac pump.

EBC and EBE-Series: Cylinder are driven by a radial pump powered by an electric motor.



Typical Bar Cutting Applications

- Commercial and residential construction
- Concrete and masonry

- Metal fabrication
- Industrial manufacturing

Productivity

- A broad range of hydraulic and electric tools quickly and easily cut through heavy-duty bar
- Highly durable, long-lasting blades outlast angle grinder or saw blades.

Safety

- Controlled cutting process enhances user safety compared with use of cut-off blades
- Minimal spark risk compared to torching, grinding and sawing methods
- Cutters produce minimal vibration, helping prevent HAVS (Hand Arm Vibration Syndrome).

▼ Enerpac's bar cutters are built to handle tough cutting applications.



EBH-Series, Hydraulic Bar Cutters



EBH-Series Hydraulic Bar Cutters

EBH-Series Hydraulic Bar Cutters are driven by a specialized external hydraulic pump for optimal power and a higher duty cycle compared with other cutter types.

These cutters are ideal for use in production or manufacturing facilities with demanding, high-volume cutting applications.

- ① Highly durable blades maintain effectiveness throughout rigorous use.
- ② Safety guard helps protect hands from injury.
- ③ Heavy-duty cutting head provides a longer operational life.
- ④ Lifting handle enables easier positioning and transport.
- ⑤ Double-acting cylinder with advance and retract buttons improves control and reduces jamming
- ⑥ External hydraulic pump helps keep the tool cool, improving operational time (pump and hose sold separately).



EBH Series



Maximum Material Hardness:

HRC 43

Maximum Material Diameter:

30 - 35 - 52 mm

Maximum Operating Pressure:

700 bar



Electric Pumps and Accessories

The EBH-Series Hydraulic Cutters are designed to work with specialized ZE4 and ZE6-Series pumps. Pump models vary by voltage type. Pump and hoses are sold separately. Both are required for the system to function. See page 208 for complete details on required pump and accessories

Page: 216



Optional Gauge Kit GKHC

Optional gauge and accessories can be used to monitor pressure in the hydraulic system. Enerpac recommends **GKHC Gauge Kit** for use with Enerpac hydraulic cutters.

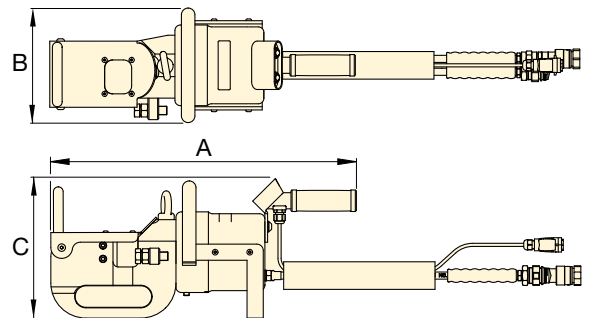

Maximum Material Diameter * (mm)	Model Number	Maximum Material Tensile Strength (daN/mm ²)	Maximum Material Hardness * (HRC)	Maximum Cutting Force (kN)	Maximum Hydraulic Operating Pressure (bar)	Dimensions (mm)			Replacement Blade Kit Model Number	
						A	B	C		
30	EBH30	60	43	445	700	480	183	221	21	EBH3001K
35	EBH35	62	43	606	700	566	213	259	48	EBH3501K
52	EBH52	50	43	1078	700	765	264	311	136	EBH5201K

* Maximum material properties indicated refer to the material to be cut.



EBE-Series, Electric Bar Cutters

The versatile EBE-Series Electric Bar Cutters quickly cut through heavy duty bar up to 26 mm in diameter without the need for an external hydraulic pump.

Their compact size and low weight enable them to be easily transported and used wherever an external power source is available.

- ① Highly durable blades maintain effectiveness throughout rigorous use.
- ② Safety guard helps protect hands from injury.
- ③ Heavy-duty cutting head provides a longer operational life.
- ④ Lifting handle enables easy positioning and transport.
- ⑤ Piston-release mechanism allows blade to be reset, reducing jamming and providing a controlled cutting process.



EBE Series



Maximum Material Hardness:

HRc 43

Maximum Material Diameter:

22 - 26 mm

Voltage*:

120 and 230 Volt

* ETL certification applies to 120 Volt tools only.

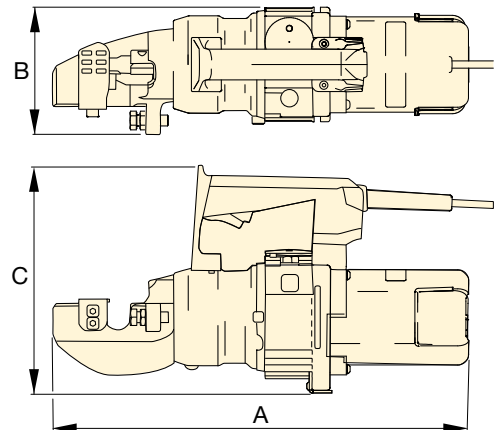

Voltage: (Model Number ending with suffix)

B = 120V, 60 Hz (with American-style NEMA 1-15 plug)

E = 230V, 50 Hz (with European-style SCHUKO plug)

Maximum Material Diameter ¹⁾ (mm)	Power Specifications				Model Number	Maximum Material Tensile Strength (daN/mm ²)	Maximum Material Hardness ¹⁾ (HRc)	Maximum Cutting Force (kN)	Dimensions (mm)			Cord Length (m)	Replacement Blade Kit Model Number	
	Volt	Hz	Amps	kW					A	B	C			
22	120	60	11	1,3	EBE22B	65	43	223	460	140	249	1,8	13,2	EBE2201K
22	230	50	6,8	1,4	EBE22E	65	43	223	460	140	249	3,0	13,2	EBE2201K
26	120	60	11	1,3	EBE26B	65	43	329	468	140	259	1,8	15,9	EBE2601K
26	230	50	6,8	1,4	EBE26E	65	43	329	468	140	259	3,0	15,9	EBE2601K

¹⁾ Maximum material properties indicated refer to the material to be cut.

EBC-Series, Cordless Bar Cutters



Cordless Bar Cutters

The highly portable EBC-Series Cordless Bar Cutters quickly and easily slice through up to number 6 rebar, or similar metal bar up to 20 mm in diameter.

A powerful 18V Lithium-ion battery provides mobility and long lasting performance, making these tools the perfect go-to solution for the jobsite, including remote locations, or anywhere an external power source is not available.

- ① Highly durable blades maintain effectiveness throughout rigorous use.
- ② Safety guard helps protect hands from injury.
- ③ Highly durable cutting head can be rotated 360 degrees to aid in the positioning of the blades on the application.
- ④ Lifting handle enables easy positioning and transport.
- ⑤ Piston-release mechanism allows blade to be reset, providing a controlled cutting process and reducing jamming.
- ⑥ Powerful 18V battery provides high performance and complete mobility.

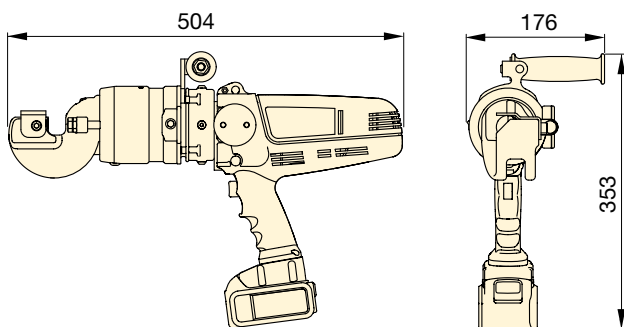

EBC Series



Maximum Material Hardness:

HRc 43

Maximum Material Diameter:

20 mm

Battery:

12 and 18 Volt

* ETL certification applies to 120 Volt tools only.



Batteries and Chargers

EBC-Series Cutters come standard with two DeWALT® 18V-5Ah lithium-ion batteries and one DeWALT® 12V or 18V charger. Additional batteries and chargers are sold separately.

EBC-Series Cutters work with DeWALT® 18V XR batteries. DeWALT® is a registered trademark of DeWALT Industrial Tool Co., which has not manufactured, licensed, approved, or endorsed this cutter product.

For Cutter Model Nr.	DeWALT® Lithium-ion Battery	Li-ion Battery Charger 12V and 18V
EBC20B	B205	BC1220B
EBC20E	B185	BC1220E

Voltage: (Model Number ending with suffix)

B = 120V, 60 Hz (with American-style NEMA 1-15 plug)

E = 230V, 50 Hz (with European-style SCHUKO plug)

Maximum Material Diameter ¹⁾ (mm)	Power Specifications			Model Number ²⁾	Maximum Material Tensile Strength ¹⁾ (daN/mm ²)	Maximum Material Hardness ¹⁾ (HRc)	Maximum Cutting Force (kN)	Replacement Blade Kit Model Number (without battery) (kg)	Replacement Blade Kit Model Number
	Battery Input Voltage (V)	Amps	kW						
20	18 - 20	46	0,83	EBC20B	65	43	190	8,7	EBC2001K
20	18 - 20	46	0,83	EBC20E	65	43	190	8,7	EBC2001K

¹⁾ Maximum material properties indicated refer to the material to be cut.

²⁾ To order an EBC-Series Cutter without batteries or a charger, remove the "B" or "E" from the Model Number, e.g. "EBC20".

▼ EDCH130, Decommissioning Cutter



Productivity

- Powerful jaws and an exceptionally large blade aperture enable use on a large variety of applications including metal tubes, communication cables, profiles and similar materials *
- Multiple pump options provide power, speed and mobility for all your applications.

Safety

- Minimal spark risk compared with torching, grinding and sawing methods
- Cutters produce minimal vibration, helping prevent HAVS (Hand Arm Vibration Syndrome).



- ① Durable blades maintain efficiency throughout rigorous use
- ② Double-acting cylinder improves control and reduces jamming
- ③ Control knob immediately stops the tool when released, improving operator safety
- ④ External hydraulic pump helps keep tool cooler and working longer (pump and hose sold separately).

EDCH Series



Maximum Material Hardness:

HRc 41

Maximum Blade Aperture:

130 - 145 - 170 mm

Maximum Operating Pressure:

700 bar



Electric Pumps and Accessories

The EDCH-Series Hydraulic Cutters are designed to work with specialized ZC3, ZE4 and ZE6-Series electric pumps. Pump models vary by voltage type. Pump and hose are all sold separately, and all are required for the system to function. See page 217 for complete details on required pumps and accessories.

Page: 217



* IMPORTANT

Do not use to cut wire rope. Use instead the EWCH-Series wire and rope cutter.

Page: 211



Optional Gauge Kit GKHC

Optional gauge and accessories can be used to monitor pressure in the hydraulic system. Enerpac recommends GKHC Gauge Kit for use with Enerpac hydraulic cutters.

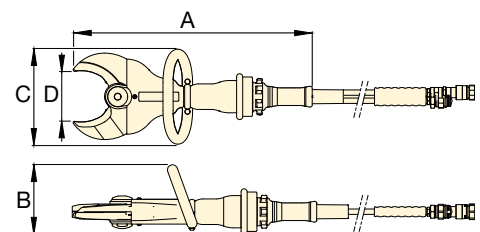

Maximum Blade Aperture * (mm)	Model Number	Maximum Material Tensile Strength (daN/mm ²)	Maximum Material Hardness * (HRc)	Maximum Operating Pressure (bar)	Dimensions (mm)				Replacement Blade Kit Model Number	
					A	B	C	D		
130	EDCH130	65	41	700	589	170	234	130	11,5	EDCH13001K
145	EDCH145	65	41	700	687	206	246	145	16,9	EDCH14501K
170	EDCH170	65	41	700	733	172	249	170	24,2	EDCH17001K

* Maximum material properties indicated refer to the material to be cut.
Do not use to cut wire rope. Use instead the EWCH-Series wire and rope cutter.

Electric Flat Bar Cutters



EFBE-Series Electric Flat Bar Cutters

EFBE-Series Electric Flat Bar Cutters enhance workplace safety by replacing unsafe cutting methods with a precise, controlled cutting solution. Unlike standard bar cutters, the deep cutting head design accommodates metal bar up to 70 mm (2¾ inch) high and over 15 mm (0.59 inch) thick.

A piston release mechanism allows the blade to be stopped and reset at any time, providing the operator with a high degree of cutting precision and control. EFBE-Series Cutters are perfect for use in industrial manufacturing facilities as well as steel and metal fabrication shops.

- ① Highly durable blades cut through flat bar, maintaining effectiveness throughout rigorous use
- ② Heavy-duty cutting head provides a longer operational life
- ③ Robust handle enables easy positioning and transport
- ④ Piston-release mechanism allows blade to be retracted, providing a controlled cutting process and reducing jamming



Voltage: (Model Number ending with suffix)

B = 120V, 60 Hz (with American-style NEMA 1-15 plug)

E = 230V, 50 Hz (with European-style SCHUKO plug)

EFBE Series



Maximum Material Hardness:

HRc 33

Maximum Material Height x Width:

50 x 17 mm / 70 x 15 mm

Voltage*:

120 and 230 Volt

* ETL certification applies to 120 Volt tools only.



Replacement Blade Kits

To order replacement parts use one of the model numbers shown below.

For Cutter Model Number	Blade Kit Model Number
EFBE5017B	EFBE501701K
EFBE5017E	
EFBE7015B	EFBE701501K
EFBE7015E	

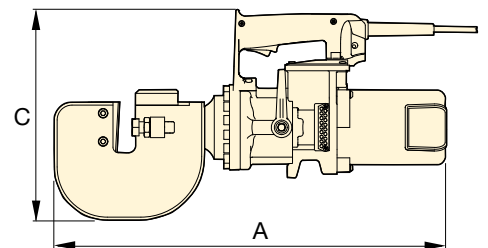
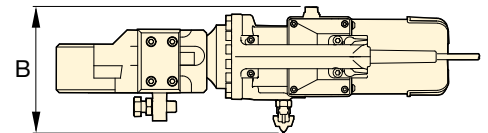

Maximum Material Dimensions ¹⁾ (mm)		Power Specifications				Model Number	Maximum Material Tensile Strength ¹⁾ (daN/mm ²)	Maximum Material Hardness ¹⁾ (HRc)	Maximum Cutting Force (kN)	Dimensions (mm)			Cord Length (m)	Weight (kg)
Height	Width	Volt	Hz	Amps	kW					A	B	C		
50	17	120	60	11	1,3	EFBE5017B	45	33	265	483	175	272	1,8	21
50	17	230	50	6,8	1,4	EFBE5017E	45	33	265	483	175	272	3,0	21
70	15	120	60	11	1,3	EFBE7015B	45	33	265	555	175	298	1,8	30
70	15	230	50	6,8	1,4	EFBE7015E	45	33	265	555	175	298	3,0	30

¹⁾ Maximum material properties indicated refer to the material to be cut.

▼ ECCE32E Electric Chain Cutter



Your Simple Solution for Cutting High-Strength Industrial Chain



Internal Mechanics

ECCE-Series: Cylinder is driven by a radial pump powered by an electric motor.



Typical Chain Cutting Applications

- Chain manufacturing
- Mining
- Rigging / material handling for transport
- Oil and gas
- Marine

Productivity

- Quickly cut through heavy-duty chain links with minimal effort
- Highly durable blades outlast angle grinder or saw blades.

Safety

- Controlled cutting process behind a protective shield enhances safety
- Precisely cut only selected link, helping prevent damage to adjacent links and weakening of chain
- Minimal spark risk compared to torching, grinding and sawing methods
- Cutters produce minimal vibration, helping prevent HAVS (Hand Arm Vibration Syndrome).



◀ Cut through chain links with ease using Enerpac's chain cutters.

ECCE-Series, Electric Chain Cutters



ECCE-Series Electric Chain Cutters

ECCE-Series Electric Chain Cutters are ideal for applications where safety is paramount. Unlike other cutting methods, Enerpac's chain cutters precisely cut selected chain links behind an enclosed, transparent safety guard.

This not only protects the operator's hands, it also helps prevent damage to adjacent links, which often results from using alternative cutting methods like torches or cut-off tools.

- ① Highly durable blades maintain effectiveness throughout rigorous use.
- ② Transparent safety guard protects hands and allows continuous monitoring for better management of cutting process.
- ③ Heavy-duty cutting head provides a longer operational life.
- ④ Lifting handle and eyebolt enable easy positioning and transport.

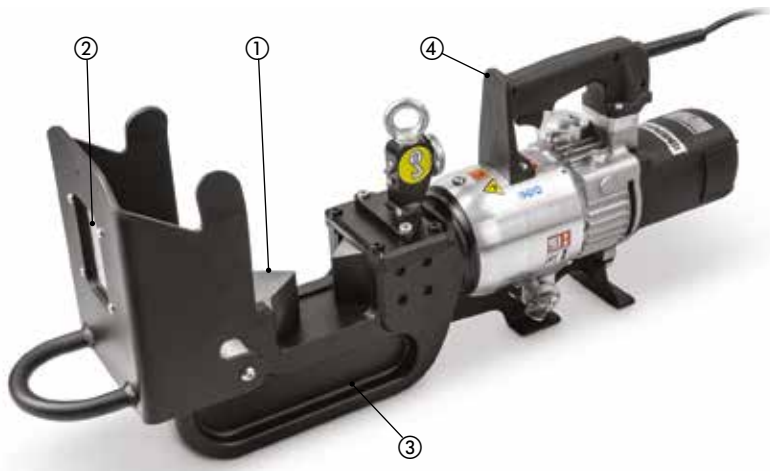

ECCE Series



Maximum Material Hardness:

HRc 46

Maximum Material Diameter:

25 - 32 mm

Maximum Grade of Chain:

100

Voltage *:

120 and 230 V

* ETL certification applies to 120 Volt tools only.

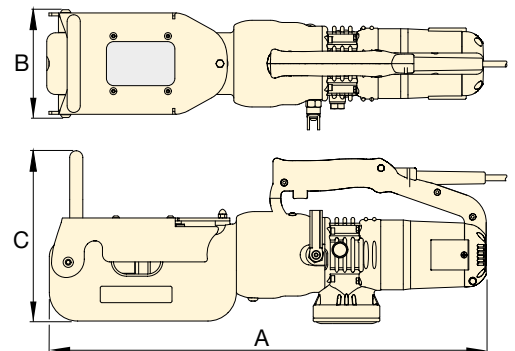

Voltage: (Model Number ending with suffix)

B = 120V, 60 Hz (with American-style NEMA 1-15 plug)

E = 230V, 50 Hz (with European-style SCHUKO plug)

Grade ¹⁾ and Maximum Material Diameter ²⁾ (mm)			Power Specifications				Model Number	Maximum Material Hardness ¹⁾ (HRc)	Maximum Cutting Force (kN)	Dimensions (mm)			Cord Length (m)	Weight (kg)	Replacement Blade Kit Model Number
Grade 70	Grade 80	Grade 100	Volt	Hz	Amps	kW				A	B	C			
25	25	13	120	60	10	1,2	ECCE26B	46	312	600	154	235	1,8	25	ECCE2601K
25	25	13	230	50	5,3	1,1	ECCE26E	46	312	600	154	235	3,0	25	ECCE2601K
32	25	19	120	60	11	1,3	ECCE32B	46	471	700	192	321	1,8	48	ECCE3201K
32	25	19	230	50	6,8	1,4	ECCE32E	46	471	700	192	321	3,0	48	ECCE3201K

¹⁾ Cutting larger chains or those of a grade higher than those recommended will result in increased wear, and may damage the tool.

²⁾ All links over 1/2" (12,7 mm) must be cut in two passes, with each pass cutting one side of the link.

▼ Shown from left to right: EWCH90 and EWCE55E



The Quick and Clean Way to Cut Cable and Wire Rope



Internal Mechanics

EWCH-Series: Cylinder is driven by an external Enerpac hydraulic pump.

EWCE-Series: Cylinder is driven by a radial pump powered by an electric motor.

Productivity

- A broad range of hydraulic and electric tools quickly and easily cut through cable and wire rope.

Safety

- Controlled cutting process enhances operator safety
- Minimal spark risk compared with torching, grinding and sawing methods
- Cutters produce minimal vibration, helping prevent HAVS (Hand Arm Vibration Syndrome).



Typical Wire and Cable Cutting Applications

- Telecommunications
- Electrical installation and maintenance
- Power generation and transmission
- Shipbuilding

▼ Guillotine-style blades make quick work of electrical cables and rope.



EWCH-Series, Hydraulic Wire and Cable Cutters



EWCH-Series Hydraulic Wire and Cable Cutters

EWCH-Series Hydraulic Wire and Cable Cutters are ideal for use in production facilities where demanding, high volume cutting applications are often encountered.

Each tool is driven by a specialized external hydraulic pump, which provides greater cutting force and allows for higher duty cycles compared with other cutter types.

- ① Guillotine-style blades maintain effectiveness throughout rigorous use.
- ② Cutting head can be opened and closed to help position material to be cut.
- ③ Eyebolt facilitates easy lifting.
- ④ Double-acting cylinder with advance and retract buttons improves control and reduces jamming.
- ⑤ External hydraulic pump helps keep tool cooler and working longer (pump and hose are sold separately).



EWCH Series



Maximum Material Hardness:

HRc 43

Maximum Material Diameter:

90 - 140 - 180 mm

Maximum Operating Pressure:

700 bar



Electric Pumps and Accessories

The EWCH-Series Hydraulic Cutters are designed to work with specialized ZE6-Series electric pumps. Pump models

vary by voltage type. Pump and hoses are sold separately. Both are required for the system to function. See page 216 for complete details on required pump and accessories

Page: **216**



Optional Gauge Kit GKHC

Optional gauge and accessories can be used to monitor pressure in the hydraulic system. Enerpac recommends **GKHC Gauge Kit** for use with Enerpac hydraulic cutters.

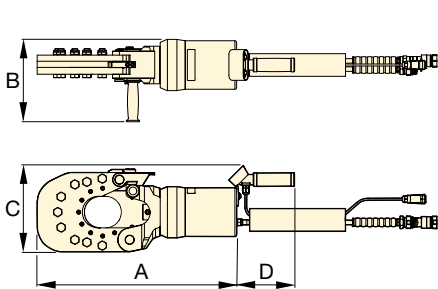

EWCH90

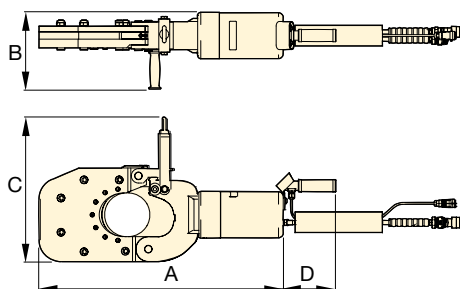

EWCH140

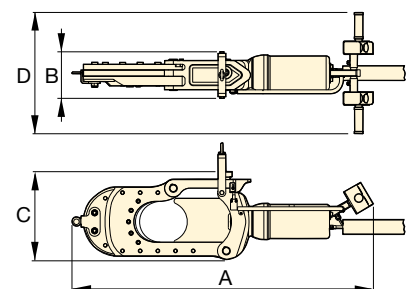

EWCH180

Maximum Material Diameter * (mm)	Model Number	Maximum Material Tensile Strength (daN/mm ²)	Maximum Material Hardness * (HRc)	Maximum Cutting Force (kN)	Maximum Hydraulic Operating Pressure (bar)	Dimensions (mm)				Replacement Blade Kit Model Number	
						A	B	C	D		
90	EWCH90	65	43	550	700	582	282	251	169	54	EWCH9001K
140	EWCH140	65	43	550	700	782	246	309	169	90	EWCH14001K
180	EWCH180	65	43	774	700	1364	211	401	551	150	EWCH18001K

* Maximum material properties indicated refer to the material to be cut.



EWCE-Series Electric Wire and Cable Cutters

EWCE-Series Electric Wire and Cable Cutters combine the efficiency and safety of their hydraulic counterparts with the greater portability of electric tools.

Their lighter weight allows for easier carrying and positioning. Available in 120V and 230V versions.

- ① Durable, guillotine-style blades maintain effectiveness throughout rigorous use.
- ② Cutting head opens wide for easy positioning of wire or cable.
- ③ Robust handles enable easy positioning and transport.
- ④ Double-acting cylinder with directional control improves handling and reduces jamming.

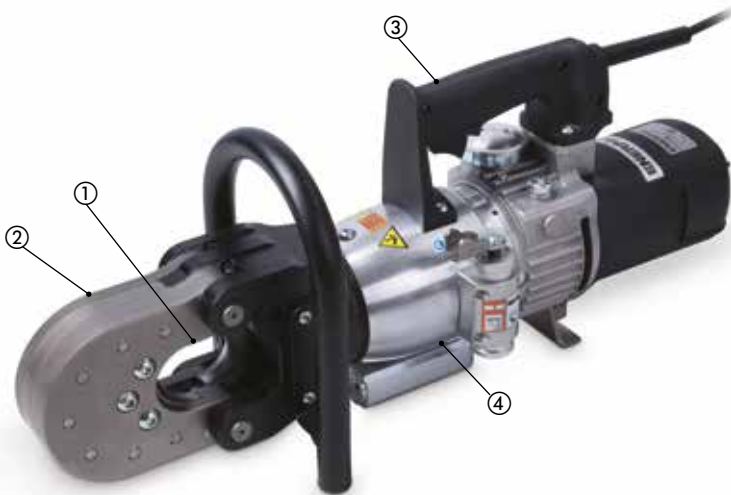

◀ Cut through wire rope and cables with ease.

EWCE Series



Maximum Material Hardness:

HRc 48

Maximum Material Diameter:

42 - 55 mm

Voltage*:

120 and 230 V

* ETL certification applies to 120 Volt tools only.

Voltage: (Model Number ending with suffix)

B = 120V, 60 Hz (with American-style NEMA 1-15 plug)

E = 230V, 50 Hz (with European-style SCHUKO plug)

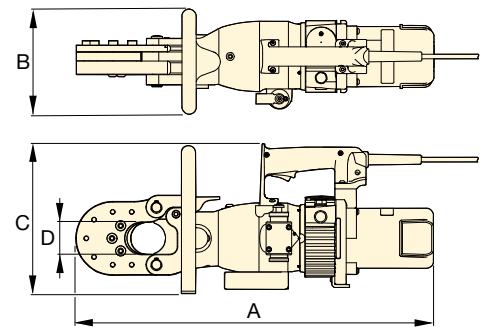

Maximum Material Diameter* (mm)		Power Specifications				Model Number	Maximum Material Hardness* (HRc)	Maximum Cutting Force (kN)	Dimensions (mm)				Cord Length (m)	Replacement Blade Kit Model Number	
Electric Cable	Wire Rope	Volt	Hz	Amps	kW				A	B	C	D			
55	42	120	60	11	1,3	EWCE55B	48	380	627	183	264	56	1,8	25	EWCE5501K
55	42	230	50	6,8	1,4	EWCE55E	48	380	627	183	264	56	3,0	25	EWCE5501K

* Maximum material properties indicated refer to the material to be cut.

ECS-Series, Cutter / Spreader Combination Tools

▼ ECSE300E



ECSE Series



Maximum Material Hardness:

HRc 41

Maximum Blade Aperture:

300 mm

Voltage*:

120 and 230 V

* ETL certification applies to 120 Volt tools only.



Internal Mechanics

ECSE-Series: Cylinder is driven by a radial pump powered by an electric motor.



Typical Chain Cutting Applications

- Industrial manufacturing
- Recycling
- Demolition

Productivity

- Blades easily cut through metal profiles, pipes, rods and other obstructions
- Wedges on tips of blades provide powerful spreading force

Safety

- Controlled cutting process creates minimal spark risk compared with torching, grinding and sawing methods

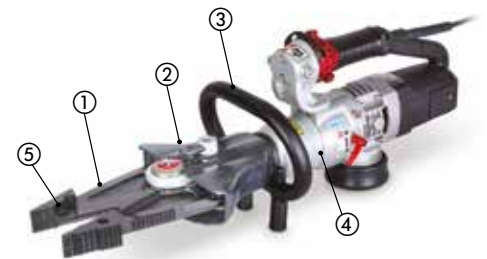
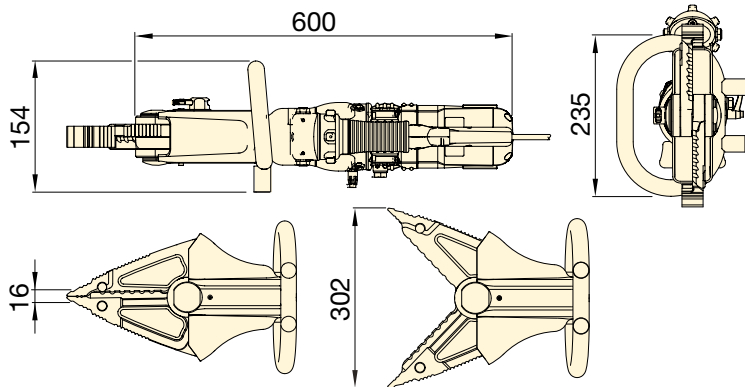

- ① Highly durable blades grip and cut through metal obstructions with ease
- ② Cutting head can be rotated 180 degrees in each direction for easier access to the application
- ③ Robust handle enables easy positioning and transport
- ④ Double-acting cylinder improves control and reduces jamming
- ⑤ Wedges provide powerful spreading force

Voltage: (Model Number ending with suffix)

B = 120V, 60 Hz (with American-style NEMA 1-15 plug)

E = 230V, 50 Hz (with European-style SCHUKO plug)

Maximum Blade Aperture (mm)	Power Specifications				Model Number	Maximum Material Tensile Strength ¹⁾ (daN/mm ²)	Maximum Material Hardness ¹⁾ (HRc)	Maximum Spreading Force ²⁾ (kN)	Cord Length (m)	Replacement Jaws Kit Model Number	
	Volt	Hz	Amps	kW							
300	120	60	10,0	1,2	ECSE300B	65	41	46	1,8	15	ECSE30001K
300	230	50	5,3	1,1	ECSE300E	65	41	46	3,0	15	ECSE30001K

¹⁾ Maximum material properties indicated refer to the material to be cut.

²⁾ 25 mm from jaw tips with jaws closed.

▼ Shown from left to right: WHC4000, WHC750



WHC, WHR, STC Series

Capacity:
3 - 20 ton

Cutting Capacity:
Ø 13 - 101 mm

Maximum Operating Pressure:
700 bar

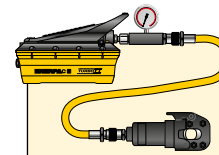

Tool-Pump Sets

Cutterheads marked with an * are available as sets (pump, tool, gauge, couplers and hose) for your ordering convenience.

Cutterhead Model Nr.	Pump Model Nr.	Set Model Number *
WHC750	P392	STC750H
WHC750	P392FP	STC750FP
WHC750	PATG1102N	STC750A
WHC1250	P392	STC1250H
WHC1250	P392FP	STC1250FP
WHC1250	PATG1102N	STC1250A

* H = Hand Pump, FP = Foot Pump, A = Air Pump

- Single-acting, spring return on all models, except WHR1250
- Guillotine action for smooth cutting operation
- Lifting handles on larger models for easy transport
- Carrying bag included for easy carrying and tool protection
- Ideal for use with most Enerpac pumps featuring 3-way valve or dump valve and 700 bar pressure rating (except WHR1250, which requires 4-way valve)
- CR400 coupler and dust cap included on all models.

Steel rope is easily cut with the smooth guillotine action of an Enerpac cutterhead. ▶



▼ Selection Chart Maximum Cutting Capacities (Ø in mm)

Cutter Head Operation	Capacity ton	Model Number	Oil Capacity (cm³)	Length (mm)	Steel Wire Rope, Hemp-core or IWRC 6x7 6x12 6x19	Round Bar				Wire Strand				Cable		Replacement Blades (kg)	
						Copper Wire or Bar	Aluminum Wire or Bar	Soft Steel Bolts	Reinforcing Bar	Bare Copper Wire Strands	Bare Aluminum Wire Strands	ACSR	Guy Steel Wire Strands	Telephone Cable CPP	Underground Cable (Power)		
Single-Acting	4	WHC750*	19,7	127	16	19	19	19	13 **	19	19	19	16	☆	☆	3,2	WCB750
	20	WHC1250*	134,4	279	31	31	31	31	25	31	31	31	22	☆	☆	11,3	WCB1250
	13	WHC2000	119,6	381	25	31	31	22	☆	51	51	51	19	☆	☆	10,4	WCB2000
	3	WHC3380	65,5	482	☆	☆	☆	☆	☆	76	76	☆	☆	85	85	9,1	WCB3380
	8	WHC4000	137,7	609	☆	☆	☆	☆	☆	89	89	☆	☆	101	101	14,5	WCB4000
Dbl.-Act.	20	WHR1250	122,9	419	31	31	31	31	25	31	31	31	22	☆	☆	11,8	WCB1250

* Available in sets with P392 Hand Pump, P392FP Foot Pump or PATG1102N Turbo Air Pump.

** Low Alloy.

☆ Will not cut designated material.

WMC-Series, Self-Contained Hydraulic Cutters

▼ Shown from left to right: WMC2200, WMC750



WMC Series

Capacity:

3 - 20 ton

Cutting Capacity:

∅ 14 - 85 mm



Replacement Blades

60-62 HRC hardened replacement blades.

For Cutter Model Number	Order Blades Model Number
WMC580	WCB750
WMC750	WCB750
WMC1000	WCB1000
WMC1250	WCB1250
WMC2200	WCB2000
WMC 3380	WCB3380

- Rotating heads for operator convenience
- Guillotine action for smooth cutting operation
- Carrying bag included for easy carrying and tool protection
- Velcro straps to secure handles on larger models for easy carry
- Spring return for easy operation
- Lightweight self-contained tool, can be used anywhere.



CAUTION !:

A “☆” in the charts on these pages means that this hydraulic cutter is not designed to cut this size or type of material. Any attempt to do so may result in personal injury and damage to the unit and will void the warranty.

▼ Selection Chart Maximum Cutting Capacities (∅ in mm)

Capacity ton	Model Number	Length (mm)	Steel Wire Rope, Hempcore or IWRC 6x7 6x12 6x19	Round Bar				Wire Strand					Cable		⚖️ (kg)
				Copper Wire or Bar	Aluminum Wire or Bar	Soft Steel Bolts	Reinforcing Bar	Bare Copper Wire Strands	Bare Aluminum Wire Strands	ACSR Wire Strands	Guy Steel Wire Strands	Guy Steel Wire Strands	Telephone Cable CPP	Underground Cable (Power)	
4	WMC580	381	16	16	16	16	10	16	16	16	14	14	☆	☆	3,6
4	WMC750	381	19	19	19	17	13 **	19	19	19	14	14	☆	☆	3,6
20	WMC1000 *	679	☆	19	19	19	19	☆	☆	☆	☆	☆	☆	☆	11,3
20	WMC1250	679	31	31	31	31	22	31	31	31	22	22	☆	☆	10,4
13	WMC2200	628	25	31	31	22	☆	51	51	51	19	19	☆	☆	10,9
3	WMC3380	660	☆	☆	☆	☆	☆	76	76	☆	☆	☆	85	85	10,0

* Cuts 12 mm alloy chain grade 70 (type G7 transport or tie-down) or grade 80 (for overhead lifting applications).

** Low Alloy.

☆ Will not cut designated material.



Pumps & Accessories for EBH & EWCH-Cutters

EBH-Series Bar Cutters and EWCH-Series Wire and Cable Cutters are powered by an external pump with an electric valve.

A twin hydraulic hose and electric cable connect the tools to the pump, allowing the user to operate them directly from a control panel located on the cutters.



ZE4-Series Pumps

Specialized **ZE4-Series** pumps provide a balance of speed and versatility, and are available in 115 and 230 volts. Recommended for use with **EBH30** and **EBH35** cutters when portability, or the convenience of using standard voltage is required.



ZE6-Series Pumps

Specialized **ZE6-Series** 3-phase pumps offer a high-flow rate that provides fast performance for demanding applications. Recommended for **EBH52** and all **EWCH** cutting applications where speed is critical, or where higher flow rates are required by the application.

ZE Series



Reservoir Capacity:

4,6 - 9,8 litres

Motor Size:

1,1 - 5,6 kW

Maximum Operating Pressure:

700 bar



Optional Gauge Kit GKHC

Optional gauge and accessories can be used to monitor pressure in the hydraulic system. Enerpac recommends **GKHC Gauge Kit** for use with Enerpac hydraulic cutters.



Hoses

EBH-and EWCH-Series Cutters require a twin hose with an electric cable. The hose comes equipped with the appropriate couplers.

Required hoses sold separately.

Description	Model Number
6,1 m long, twin hose with couplers, sheath & electric cable	CH720EC

Pump Voltage 1-phase: (Model Number ending with suffix)

B = 120V, 60 Hz (with American-style NEMA 5-15 plug)

E = 230V, 50 Hz (with European-style SCHUKO plug)

I = 230V, 50 Hz (with NEMA 6-15 plug)

Pump Series	Pump Model Number *	Motor Electrical Specifications (Volt - Phase, 50-60 Hz)	Motor Size (kW)	Reservoir Capacity (litres)	Dimensions (mm)			Weight (kg)	Required Twin Hose Model Number (Sold separately)	Compatible Cutter Model Number (Sold Separately)
					Height	Length	Width			
ZE4	ZE4404XB	115 V - 1 ph	1,1	4,6	513	521	279	45	CH720EC	EBH30 EBH35
	ZE4404XE	208-240 V - 1 ph								
	ZE4404XI	208-240 V - 1 ph								
ZE6 ¹⁾	ZE6410XG-S	208-240 V - 3 ph	5,6	9,8	384	559	384	77	CH720EC	All EBH and EWCH-Series Cutters
	ZE6410XJ-S	460-480 V - 3 ph								
	ZE6410XK-S	440 V - 3 ph								
	ZE6410XW-S	380-415V - 3 ph								

* Indicated pumps come equipped with appropriate configurations to work with indicated cutters.

¹⁾ ZE6 pumps are available with roll cages. To add a roll cage, add an "R" prior to the "S" in the model number: example **ZE6410XG-RS**.

Pumps & Accessories for EDCH-Cutters



Pumps & Accessories for EDCH-Cutters

The EDCH-Decommissioning Cutters are designed to work in a wide variety of environments, from factories to demolition projects.

Enerpac offers multiple pump options to provide power, speed and mobility for all your applications.

ZC ZE Series



Reservoir Capacity:

4,6 - 9,8 litres

Motor Size:

1,0 - 1,1 - 5,6 kW

Maximum Operating Pressure:

700 bar



ZC3-Series Cordless Pumps

Specialized **ZC3-Series** Cordless Pumps offer the portability of a cordless tool without the added weight of an integrated motor, combining freedom of movement with ease of use. Recommended for use with the **EDCH130** cutter.



ZE4-Series Pumps

Specialized **ZE4-Series** Pumps provide a balance of speed and versatility. Recommended for use with all **EDCH** cutters when the convenience of using standard voltage is required.



ZE6-Series Pumps

Specialized **ZE6-Series** pumps offer a high-flow rate that provides fast performance. Recommended for use with all **EDCH** cutters when 3-phase power is available, and speed is critical.



Optional Gauge Kit GKHC

Optional gauge and accessories can be used to monitor pressure in the hydraulic system. Enerpac recommends **GKHC Gauge Kit** for use with Enerpac hydraulic cutters.



Twin Hose

EDCH-Series Cutters require a twin hose for operation. The hose comes equipped with the appropriate couplers.

Description	Model Number
6,1 m long, twin hose with couplers	CH720MC

Pump Voltage 1-phase: (Model Number ending with suffix)

B = 120V, 60 Hz (with American-style NEMA 5-15 plug);

E = 230V, 50 Hz (with European-style SCHUKO plug); **I** = 230V, 50 Hz (with NEMA 6-15 plug)

Pump Series	Pump Model Number *	Motor Electrical Specifications (Volt - Phase, Hz)	Motor Size (kW)	Reservoir Capacity (litres)	Dimensions (mm)			Weight (kg)	Required Twin Hose Model Number (Sold separately)	Compatible Cutter Model Number (Sold Separately)
					Height	Length	Width			
ZC3	ZC3204XB	Cordless (115 V Charger 60 Hz)	1,0	4,6	653	472	363	27	CH720MC	EDCH130
	ZC3204XE	Cordless (230 V Charger 50 Hz)								
ZE4	ZE4204XB	115 V - 1 ph, 50-60 Hz	1,1	4,6	513	521	279	45	CH720MC	EDCH130 EDCH145 EDCH170
	ZE4204XE	208-240 V - 1 ph, 50-60 Hz								
	ZE4204XI	208-240 V - 1 ph, 50-60 Hz								
ZE6 ¹⁾	ZE6210XG-S	208-240 V - 3 ph	5,6	9,8	384	559	384	77	CH720MC	EDCH130 EDCH145 EDCH170
	ZE6210XJ-S	460-480 V - 3 ph								
	ZE6210XK-S	440 V - 3 ph								
	ZE6210XW-S	380-415V - 3 ph								

* Indicated pumps come equipped with appropriate configurations to work with indicated cutters.

¹⁾ ZE6 pumps are available with roll cages. To add a roll cage, add an "R" prior to the "S" in the model number: example **ZE6410XG-RS**.

Enerpac's Bolting Solutions cater to the complete bolting work-flow, ensuring joint integrity in a variety of applications throughout the industry:

Joint Assembly

From simple pipe alignment to complex joint positioning of large structural assemblies, our comprehensive line of joint assembly products range from hydraulic and mechanical alignment tools to synchronized PLC-controlled multi-point positioning systems.

Controlled Tightening – Torque & Tensioning

Enerpac offers a variety of controlled tightening options to best meet the requirements of your application. From mechanical torque multipliers to hydraulic, pneumatic and electric square drive wrenches and from low profile torque wrenches to interconnectable bolt tensioning tools; we offer the products you need for accurate and simultaneous tightening of multiple bolts.

Joint Separation

Enerpac also provides hydraulic nut splitters and a variety of mechanical and hydraulic spreading tools for joint separation during inspection, maintenance and decommissioning operations.

High quality bolting solutions from the brand you can trust. See how Enerpac can make your bolting work-flow more accurate, safer and efficient.



Bolting Integrity Software

Enerpac Bolting Integrity Software Solutions play a key role in implementing and managing an Integrity Program for bolted connections.

The software offers Tool selection, Bolt Load calculations and Tool pressure settings, as well as, a combined Application Data Sheet and Joint Completion Report. Custom Joint information can also be entered.

Page: 422



Torque Tightening & Tensioning

See our 'Yellow Pages' for information on torque tightening. See our Bolting Safety Instructions on enerpac.com.

Page: 405





























Flange Maintenance Tools

The range of patented flange spreading tools have been developed to aid and simplify the maintenance of flange joints.

Page: 327



Bolting Tools & Pumps Section Overview

	Capacity	Tool type and functions	Series		Page
Controlled Tightening and Loosening – Torque & Tensioning	1952 - 35.455 Nm 1440 - 26.150 Ft.lbs	Square Drive Hydraulic Torque Wrenches Rigid steel design & maximum versatility	S		220 ▶
	19-155 mm 3/4 - 6 1/8" 27-120 mm 1 1/16-4 15/16"	Heavy-Duty Impact Sockets Back-Up Spanners for Torque Wrenches	BSH BUS		224 ▶ 225 ▶
	46 - 75 mm hexagon 1 13/16 - 3 1/8" hexagon	Safe T™ Torque Lock Hands-free torque wrench system	STTL		226 ▶
	2766 - 47.454 Nm 2040 - 35.000 Ft.lbs	Hexagon Hydraulic Torque Wrenches Ultra-Slim Stepped Width Cassettes	W WSL		228 ▶
	1909 - 37.965 Nm 1408 - 28.002 Ft.lbs	Hexagon and Square Drive Torque Wrenches One drive, two tools	RSL, RLP RSQ		242 ▶ 252 ▶
	1913- 32.617 Nm 1411- 24.057 Ft.lbs	Square Drive Aluminum Torque Wrenches Setting Industry-First Safety Standards	DSX		254 ▶
	2089 - 18.289 Nm 1541 - 13.489 Ft.lbs	Drive Units, Hexagon Cassettes & Square Drive Torque Wrenches	HMT, HLP HSQ		258 ▶ 262 ▶
	1015 - 10.845 Nm 750 - 8000 Ft.lbs	Manual Torque Multipliers Pneumatic Torque Wrenches	E PTW		264 ▶ 266 ▶
	2900 - 21.800 Nm 2140 - 16.100 Ft.lbs	Safe T™ Torque Checker Accurate mobile torque system safety testing	STTC		270 ▶
	200 - 10.000 Nm 148 - 7375 Ft.lbs	Mobile Calibration System For continuous rotation tools and hydraulic wrenches	MCS		272 ▶
		Selection Matrix Optimum Wrenches - Pump - Hoses			273 ▶
	Flow: 0,25 l/min Power: 0,37 kW	Battery-Powered Torque Pumps Cordless Hydraulic Power	XC		274 ▶
	Flow: 0,52 l/min Power: 0,63 kW	E-Pulse® Electric Torque Pumps Compact and Portable	E-Pulse®		276 ▶
	Flow: 0,50 l/min Power: 0,75 kW	Electric Torque Pumps Lightweight	TQ		278 ▶
	Flow: 0,90 l/min Power: 1,25 kW	Portable Electric Torque Pumps Z-Class innovation	ZU4T		280 ▶
	Flow: 0,82-1,64 l/min Power: 1,1 - 2,2 kW	Electric Torque Pumps Z-Class innovation	ZE4T ZE5T		284 ▶
	Flow: 0,4 l/min Air: 1389 l/min	Air Hydraulic Torque Pump Lightweight and Compact	LAT		286 ▶
	Flow: 1,0 l/min Air: 2840 l/min	Air Driven Torque Pumps Z-Class innovation	ZA4T		288 ▶
	134 - 4650 kN 224 - 3958 kN	HydraMax® Topside Bolt Tensioners Topside Bolt Tensioners	HM GT		294 ▶ 298 ▶
	151 - 2321 kN	Aquajack® Subsea Bolt Tensioners	EAJ		300 ▶
203 - 2969 kN 373 - 2736 kN	Power Generation Bolt Tensioners Foundation Bolt Tensioners	PGT FTR, FTE		302 ▶ 304 ▶	
Flow: 0,61 cm³/stroke 1,0 - 270 metres	1500 bar High-Pressure Hand Pump 1500 bar Hoses, Hose Reels and Couplers	HPT HT, B		308 ▶ 309 ▶	
Flow: 0,33 l/min Flow: 0,07 l/min	Electric Tensioning Pumps Ultra-High Pressure Air Pump	ZUTP ATP		310 ▶ 311 ▶	
Joint Assembly and Separation	1 - 9 ton (10 - 90 kN)	Flange Alignment Tools	ATM		314 ▶
	8 - 14 ton (72 - 125 kN)	Step-type Industrial Spreaders	FSC, FSH FSM		316 ▶
	Hexagon: 10 - 130 mm Bolt range: M6 - M90	Hydraulic Nut Splitters	NC NSC, NSH		318 ▶ 320 ▶
	ø 1 - 12 inch flanges	QuickFace – Mechanical Pipe Flange Face Tool	FF		324 ▶

▼ Shown: S3000PX



Safety and Performance

- Compact, high-strength uni-body construction provides a small operating radius without sacrificing endurance
- 35° rotation angle and rapid return stroke for fast operation
- Tough manifold design with added safety feature for enhanced operator safety

Simplicity

- 360° click-on reaction arm with quick release lever provides easier handling, even with gloves on
- Includes robust handle which mounts on both sides of tool for extra maneuverability
- Push button square drive release for quickly reversing the square drive for tightening or loosening

Versatility

- Available with optional enhanced tilt and swivel TSP300 manifold for horizontal and vertical maneuverability, with greater durability ¹⁾

Accuracy

- Constant torque output provides accuracy of $\pm 3\%$ across full stroke
- Optional Angle-of-Turn Indicator provides measurement of rotation.

¹⁾ TSP300 is designed for X-Edition tools only, and is not compatible with previous edition tools. For replacement components for existing tools, refer to repair sheet on www.enerpac.com

Setting New Standards in Safety, Simplicity and Performance



Two Handle Styles

Robust angled positioning handle comes standard with every S-Series (X-Edition) tool. Straight positioning handles are available as accessories.

Compatible S-Series (X-Edition) wrenches	Model Nr. Angled positioning handles (standard)	Model Nr. Straight positioning handles (optional)
S1500X, S3000X	SWH6A	SWH6S
S6000X, S11000X	SWH10A	SWH10S
S25000X	SWH10EA ²⁾	

²⁾ SWH10EA is an eyebolt handle.



TSP300 Tilt & swivel manifold

Standard TSP300 tilt and swivel manifold with robust interlocking design provides 360° X-axis rotation and 160° Y-axis rotation.

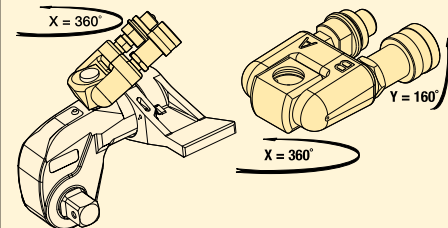

ATEX declared. Calibration certificate included.

All X-edition tools are CE - ATEX declared and are shipped complete with a calibration certificate.



Back-Up Spanners

Hands free tool to be used to stop the back nut from turning during make up or break out.

X-Edition, Square Drive Hydraulic Torque Wrenches

Standard are: ① ② ④ ⑥ ⑧
Other items are optional.

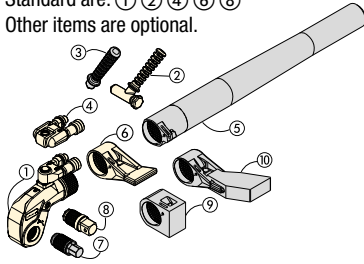

- ① Drive Unit
- ② Angeled Positioning Handle
- ③ Straight Positioning Handle
- ④ Pro Series Swivel
- ⑤ Reaction Tube Extension
- ⑥ Standard Reaction Arm
- ⑦ Allen-Key Drive
- ⑧ Square Drive
- ⑨ Short Reaction Arm
- ⑩ Extended Reaction Arm

Select the Right Torque
Choose your Enerpac Torque Wrench using the untightening rule of thumb:
Loosening torque equals about 250% of tightening torque.

S Series X-Edition



Nominal Torque Output:
35.455 Nm

Square Drive Range:
3/4 - 2 1/2 inch

Nose Radius:
25 - 64 mm

Maximum Operating Pressure:
690 bar

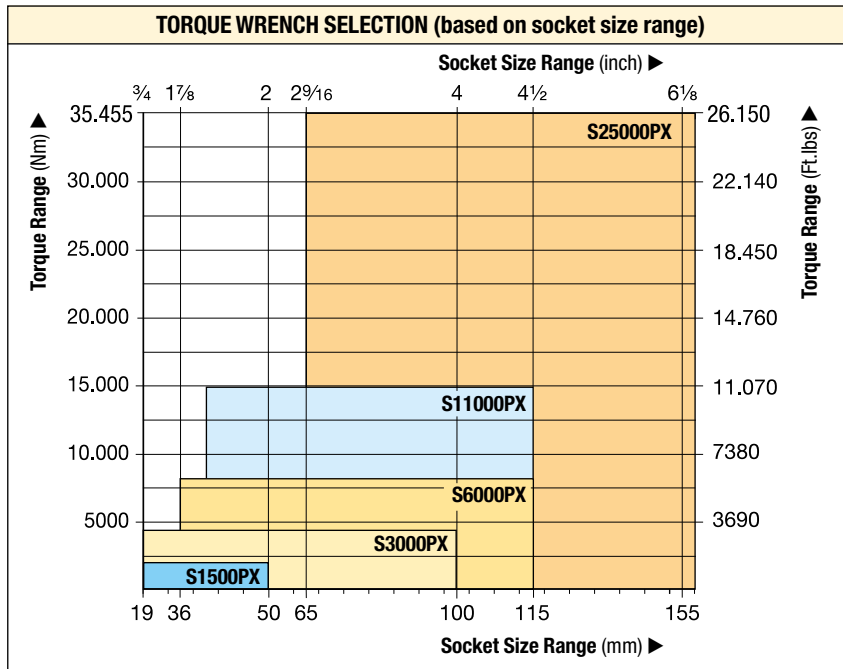

Use only Heavy Duty Impact Sockets
For power driven torquing equipment, according to ISO2725 and ISO1174; DIN 3129 and DIN 3121 or ASME-B107.2/1995.

Page: **224**

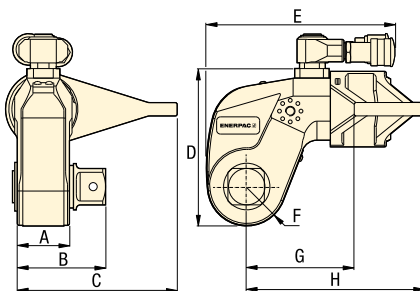

Torque Pump Selection Matrix
For optimum speed and performance see the torque wrench, pump and hoses matrix.

Page: **273**

Safe™ Torque Lock
The Safe™ Torque Lock is suitable for all bolted applications from 190 Nm to 15.000 Nm using a heavy duty impact socket.

The patented mechanical locking system creates a hands-free torque wrench solution suitable for Enerpac only square drive tools.

Suitable for S3000PX, S6000PX and S11000PX.

Page: **226**

Nominal Torque at 690 bar		Minimum Torque at 69 bar		Square Drive Size (inch)		Angle-of-Turn Model Nr. (optional)	Torque Wrench Model Number *	Dimensions (mm)								Weight (kg)
(Nm)	(Ft.lbs)	(Nm)	(Ft.lbs)	Model Nr. (included with wrench)	Model Nr. (optional)			A	B	C	D	E	F	G	H	
1952	1440	195	144	3/4	SD15-012	AOT15	S1500PX	39	65	108	97	136	25	70	129	3,2
4373	3225	438	323	1	SD30-100	AOT30	S3000PX	48	78	135	128	173	33	90	161	5,6
8338	6150	834	615	1 1/2	SD60-108	AOT60	S6000PX	55	92	169	157	192	40	110	188	9,2
15.151	11.175	1516	1118	1 1/2	SD110-108	AOT110	S11000PX	72	114	197	190	228	50	133	229	15,8
35.455	26.150	3545	2615	2 1/2	SD250-208	AOT250	S25000PX	89	143	246	244	287	64	182	295	32,2

* To order a S-Series (X-edition) torque wrench without a TSP300 tilt and swivel manifold, remove the "P" prior to the "X" in the tool model number, example: **S1500X**.

Maximum Torque at 690 bar:

35.455 Nm

Hexagon Size Allen Drive:

1/2 - 2 1/4 inch

Hexagon Size Allen Drive:

14 - 85 mm

For
S
Series

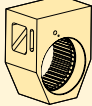
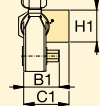

Torque Wrench 	Optional Allen Drives, Imperial				Optional Allen Drives, Metric				Short Reaction Arm for Allen Drives  		
	Hexagon Size ¹⁾ (inch)	Maximum Torque (Nm)	Model Number	Dim. B1 (mm)	Hexagon Size ¹⁾ (mm)	Maximum Torque (Nm)	Model Number	Dim. B1 (mm)	Model Number	Dimensions (mm) C1 H1	
S1500PX (1952 Nm)	1/2	481	SDA15008	66	14	644	SDA1514	66	SRA15X	67,5	74
	5/8	936	SDA15010	67	17	1152	SDA1517	68			
	3/4	1620	SDA15012	71	19	1607	SDA1519	70			
	7/8	1952	SDA15014	74	22	1952	SDA1522	73			
	1	1952	SDA15100	77	24	1952	SDA1524	74			
S3000PX (4373 Nm)	5/8	936	SDA30010	77	17	1152	SDA3017	77	SRA30X	80,0	74
	3/4	1620	SDA30012	80	19	1607	SDA3019	79			
	7/8	2569	SDA30014	83	22	2488	SDA3022	82			
	1	3830	SDA30100	86	24	3234	SDA3024	84			
	1 1/8	4373	SDA30102	88	27	4373	SDA3027	85			
	1 1/4	4373	SDA30104	89	30	4373	SDA3030	87			
	-	-	-	-	32	4373	SDA3032	88			
S6000PX (8338 Nm)	5/8	936	SDA60010	85	17	1152	SDA6017	86	SRA60X	91,5	89
	3/4	1620	SDA60012	89	19	1607	SDA6019	88			
	7/8	2569	SDA60014	92	22	2488	SDA6022	91			
	1	3830	SDA60100	95	24	3234	SDA6024	93			
	1 1/8	5457	SDA60102	97	27	4603	SDA6027	94			
	1 1/4	7484	SDA60104	98	30	6311	SDA6030	96			
	-	-	-	-	32	7660	SDA6032	97			
S11000PX (15.151 Nm)	1 1/4	7484	SDA110104	115	30	6311	SDA11030	112	SRA110X	127,5	106
	1 3/8	9958	SDA110106	117	32	7660	SDA11032	114			
	1 1/2	12.928	SDA110108	118	36	10.901	SDA11036	117			
	1 5/8	15.151	SDA110110	122	41	15.151	SDA11041	121			
	1 3/4	15.151	SDA110112	125	46	15.151	SDA11046	127			
S25000PX (35.455 Nm)	1 1/2	12.928	SDA250108	141	36	10.901	SDA25036	140	SRA250X	158,5	135
	1 5/8	16.433	SDA250110	145	41	16.107	SDA25041	144			
	1 3/4	20.520	SDA250112	148	46	22.744	SDA25046	148			
	1 7/8	25.245	SDA250114	149	50	29.211	SDA25050	151			
	2	30.635	SDA250200	151	55	35.455	SDA25055	154			
	2 1/4	35.455	SDA250204	154	60	35.455	SDA25060	158			
	-	-	-	-	65	35.455	SDA25065	161			
	-	-	-	-	70	35.455	SDA25070	164			
	-	-	-	-	75	35.455	SDA25075	168			
	-	-	-	-	85	35.455	SDA25085	175			

¹⁾ See page 417 for table of hexagon sizes of bolts, nuts and related thread diameters.

Accessories for S-Series, X-Edition Wrenches

Standard are: ① ② ④ ⑥ ⑧
Other items are optional.

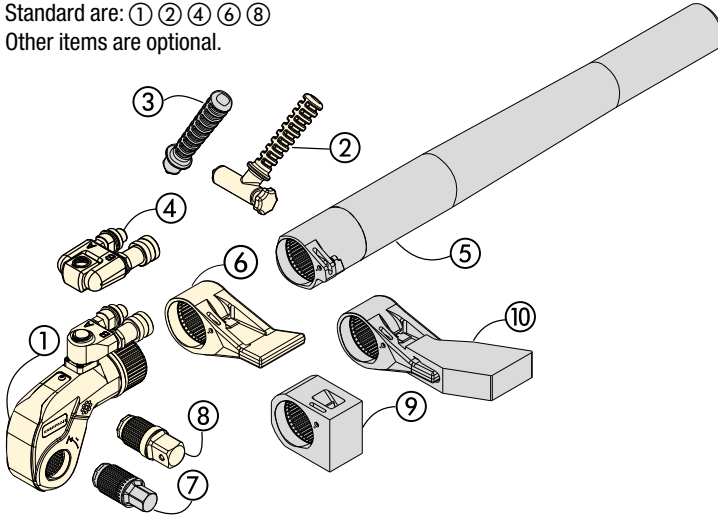

- ① Drive Unit
- ② Angeled Positioning Handle
- ③ Straight Positioning Handle
- ④ Pro Series Swivel
- ⑤ Reaction Tube Extension
- ⑥ Standard Reaction Arm
- ⑦ Allen-Key Drive
- ⑧ Square Drive
- ⑨ Short Reaction Arm
- ⑩ Extended Reaction Arm

RTEX SRSX Series



RTEX-Series, Reaction Tube Extensions

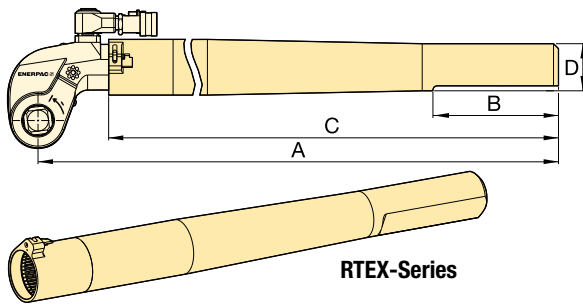

- Full torque rated
- Increases tool fit in restricted access areas

For Torque Wrench Model Number	Model Number	Dimensions (mm)				Weight (kg) *
		A	B	C	D	
S1500PX	RTE15X	706	152	636	58	4,6
S3000PX	RTE30X	733	152	647	57	5,5
S6000PX	RTE60X	747	152	659	65	7,7
S11000PX	RTE110X	769	152	675	76	11,2
S25000PX	RTE250X	813	152	685	100	17,3

* Weights indicated are for the accessories only and do not include the wrench.

SRSX-Series, Extended Reaction Arms

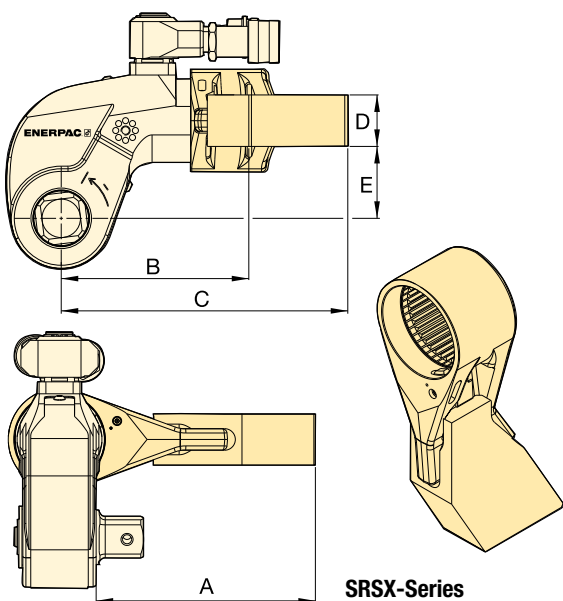

- Lightweight interchangeable design

For Wrench Model	Max. Torque (Nm)	Model Number	Dimensions (mm)					Weight (kg) *
			A	B	C	D	E	
S1500PX	1801	SRS151X	94	86	127	24	34	0,8
	1641	SRS152X	119	97	138	24	34	1,0
	1533	SRS153X	145	109	148	24	34	1,2
S3000PX	3918	SRS301X	111	106	168	34	48	1,6
	3712	SRS302X	137	117	182	34	48	2,0
	3574	SRS303X	162	132	198	34	48	2,5
S6000PX	7842	SRS601X	138	128	192	39	62	2,3
	7454	SRS602X	163	144	207	39	62	2,7
	7175	SRS603X	189	159	222	39	62	3,4
S11000PX	14.650	SRS1101X	149	157	232	46	76	4,4
	13.957	SRS1102X	175	172	247	46	76	5,1
	13.391	SRS1103X	200	187	261	46	76	5,8
S25000PX	33.538	SRS2501X	183	209	295	50	100	7,6
	32.049	SRS2502X	208	222	310	50	100	8,4
	30.750	SRS2503X	233	236	326	50	100	10,0

* Weights indicated are for the accessories only and do not include the wrench.

- Heavy-duty impact sockets
- Supplied with "Pin and O-Ring"

BSH Series



Hexagon Sizes (A/F):

19 - 155 mm | 3/4 - 6 1/8"

METRIC SOCKETS							
3/4" Square Drive		1" Square Drive		1 1/2" Square Drive		2 1/2" Square Drive	
A/F (mm)	Model Number	A/F (mm)	Model Number	A/F (mm)	Model Number	A/F (mm)	Model Number
19	BSH7519	19	BSH1019	36	BSH1536	65	BSH2565
24	BSH7524	24	BSH1024	41	BSH15163	70	BSH2570
27	BSH7527	27	BSH1027	46	BSH1546	75	BSH2575
30	BSH7530	30	BSH1030	50	BSH1550	80	BSH2580
32	BSH7532	32	BSH1032	55	BSH1555	85	BSH2585
36	BSH7536	36	BSH1036	60	BSH1560	90	BSH2590
41	BSH75163	41	BSH10163	65	BSH1565	95	BSH2595
46	BSH7546	46	BSH1046	70	BSH1570	100	BSH25100
50	BSH7550	50	BSH1050	75	BSH1575	105	BSH25105
-	-	55	BSH1055	80	BSH1580	110	BSH25110
-	-	60	BSH1060	85	BSH1585	115	BSH25115
-	-	65	BSH1065	90	BSH1590	120	BSH25120
-	-	70	BSH1070	95	BSH1595	125	BSH25125
-	-	75	BSH1075	100	BSH15100	135	BSH25135
-	-	80	BSH1080	105	BSH15105	140	BSH25140
-	-	85	BSH1085	110	BSH15110	145	BSH25145
-	-	90	BSH1090	115	BSH15115	150	BSH25150
-	-	95	BSH1095	-	-	155	BSH25155
-	-	100	BSH10100	-	-	-	-

Select the Right Torque

Choose your Enerpac Torque Wrench using the untightening rule of thumb: Loosening torque equals about 250% of tightening torque.

Page: **418**

Hexagon Bolt and Nut Sizes

See the table of hexagon sizes of bolts, nuts and related thread diameters.

Page: **417**

IMPERIAL SOCKETS													
3/4" Square Drive		1" Square Drive				1 1/2" Square Drive				2 1/2" Square Drive			
A/F (inch)	Model Number	A/F (inch)	Model Number	A/F (inch)	Model Number	A/F (inch)	Model Number	A/F (inch)	Model Number	A/F (inch)	Model Number	A/F (inch)	Model Number
3/4"	BSH7519	3/4"	BSH1019	2 5/16"	BSH10231	1 7/16"	BSH15144	2 13/16"	BSH15281	2 7/16"	BSH25244	4 3/16"	BSH25419
7/8"	BSH75088	7/8"	BSH10088	2 3/8"	BSH10238	1 1/2"	BSH1538	2 7/8"	BSH15288	2 1/2"	BSH25250	4 1/4"	BSH25425
1 5/16"	BSH75094	1 5/16"	BSH10094	2 7/16"	BSH10244	1 9/16"	BSH15156	2 15/16"	BSH1575	2 13/16"	BSH2565	4 5/16"	BSH25110
1 1/16"	BSH7527	1 1/16"	BSH1027	2 1/2"	BSH10250	1 5/8"	BSH15163	3"	BSH15300	2 5/8"	BSH25263	4 3/8"	BSH25438
1 3/16"	BSH7530	1 3/16"	BSH1030	2 9/16"	BSH1065	1 11/16"	BSH1543	3 1/16"	BSH15306	2 11/16"	BSH25269	4 1/2"	BSH25450
1 1/4"	BSH75125	1 1/4"	BSH10125	2 5/8"	BSH10263	1 3/4"	BSH15175	3 1/8"	BSH15313	2 3/4"	BSH2570	4 5/8"	BSH25463
1 5/16"	BSH75131	1 5/16"	BSH10131	2 11/16"	BSH10269	1 13/16"	BSH1546	3 3/16"	BSH15319	2 11/16"	BSH25281	4 3/4"	BSH25475
1 3/8"	BSH7535	1 3/8"	BSH1035	2 3/4"	BSH1070	1 7/8"	BSH15188	3 1/4"	BSH15325	2 7/8"	BSH25288	4 7/8"	BSH25488
1 7/16"	BSH75144	1 7/16"	BSH10144	2 13/16"	BSH10281	1 15/16"	BSH15194	3 3/8"	BSH15338	2 15/16"	BSH2575	5"	BSH25500
1 1/2"	BSH7538	1 1/2"	BSH1038	2 7/8"	BSH10288	2"	BSH15200	3 1/2"	BSH15350	3"	BSH25300	5 1/8"	BSH25513
1 9/16"	BSH75156	1 9/16"	BSH10156	2 15/16"	BSH1075	2 1/16"	BSH15206	3 5/8"	BSH15363	3 1/16"	BSH25306	5 3/16"	BSH25519
1 5/8"	BSH75163	1 5/8"	BSH10163	3"	BSH10300	2 1/8"	BSH15213	3 3/4"	BSH1595	3 1/8"	BSH25313	5 1/4"	BSH25525
1 11/16"	BSH7543	1 11/16"	BSH1043	3 1/16"	BSH10306	2 3/16"	BSH15219	3 7/8"	BSH15388	3 3/16"	BSH25319	5 3/8"	BSH25538
1 3/4"	BSH75175	1 3/4"	BSH10175	3 1/8"	BSH10313	2 1/4"	BSH15225	3 15/16"	BSH15100	3 1/4"	BSH25325	5 1/2"	BSH25140
1 13/16"	BSH7546	1 13/16"	BSH1046	3 3/16"	BSH10319	2 5/16"	BSH15231	4"	BSH15400	3 3/8"	BSH25338	5 3/4"	BSH25575
1 7/8"	BSH75188	1 7/8"	BSH10188	3 1/4"	BSH10325	2 3/8"	BSH15238	4 1/8"	BSH15105	3 1/2"	BSH25350	5 7/8"	BSH25150
1 15/16"	BSH75194	1 15/16"	BSH10194	3 3/8"	BSH10338	2 7/16"	BSH15244	4 3/16"	BSH15419	3 5/8"	BSH25363	6"	BSH25600
2"	BSH75200	2"	BSH10200	3 1/2"	BSH10350	2 1/2"	BSH15250	4 1/4"	BSH15425	3 3/4"	BSH2595	6 1/8"	BSH25613
-	-	2 1/16"	BSH10206	3 5/8"	BSH10363	2 9/16"	BSH1565	4 5/16"	BSH15110	3 7/8"	BSH25388	-	-
-	-	2 1/8"	BSH10213	3 3/4"	BSH1095	2 5/8"	BSH15263	4 3/8"	BSH15438	3 15/16"	BSH25100	-	-
-	-	2 3/16"	BSH10219	3 7/8"	BSH10388	2 11/16"	BSH15269	4 1/2"	BSH15450	4"	BSH25400	-	-
-	-	2 1/4"	BSH10225	-	-	2 3/4"	BSH1570	4 5/8"	BSH15463	4 1/8"	BSH25105	-	-

Back-Up Spanners for Torque Wrenches

▼ BUS03 Back-Up Spanner (safety cable not shown)



- Hands free solution – improves operator safety
- Eliminates the need for flogging spanners
- Speeds up the bolting process
- Includes safety cable with quick-connect carabiner's, stainless steel tethers and secure Allen-key fixings
- Won't lock on during operations
- Lightweight, spark-free and non-impact for improved safety and ease of use.
- Two hexagon sizes in one tool, so fewer tools to carry.

▼ SELECTION CHART BACK-UP SPANNERS

Hexagon Sizes (A/F)		Model Number	Dimensions (mm)				 (kg)
S1 to S2 (mm)	S1 to S2 (inch)		A	B	C	D	
27 - 32	1 ¹ / ₁₆ - 1 ¹ / ₄ "	BUS01	51	98	15	M8	0,3
36 - 41	1 ⁷ / ₁₆ - 1 ⁵ / ₈ "	BUS02	62	119	15	M8	0,4
46 - 50	1 ¹³ / ₁₆ - 2"	BUS03	75	141	20	M8	0,6
55 - 60	2 ³ / ₁₆ - 2 ³ / ₄ "	BUS04	89	166	20	M12	0,8
65 - 70	2 ⁹ / ₁₆ - 2 ³ / ₄ "	BUS05	100	190	25	M16	1,0
75 - 80	2 ¹⁵ / ₁₆ - 3 ¹ / ₈ "	BUS06	112	213	25	M16	1,3
-	3 ¹ / ₂ - 3 ⁷ / ₈ "	BUS07	135	257	30	M20	2,2
-	4 ¹ / ₄ - 4 ⁵ / ₈ "	BUS08	163	310	30	M20	3,3
85 - 90	-	BUS09	126	242	25	M16	1,7
95 - 100	3 ³ / ₄ - 3 ¹⁵ / ₁₆ "	BUS10	138	266	30	M20	2,3
105 - 110	4 ¹ / ₈ - 4 ¹⁵ / ₁₆ "	BUS11	153	297	30	M20	3,1
115 - 120	-	BUS12	165	320	30	M20	3,5

BUS Series

Hexagon Sizes (A/F):

27 - 120 mm

Hexagon Sizes (A/F):

1¹/₁₆ - 4¹⁵/₁₆ inch



Back-Up Spanners

Hands free operation of a hydraulic torque wrench improves the safety of the operator significantly.

Enerpac Back-Up Spanners are a hands free tool that eliminates the need to use a flogging spanner as a backing tool.

The Back-Up Spanners have been specifically designed to prevent them from locking onto the nut during bolt torquing operations. They fit easily onto the back nut and prevent it from turning during make up or break out of bolted joints.

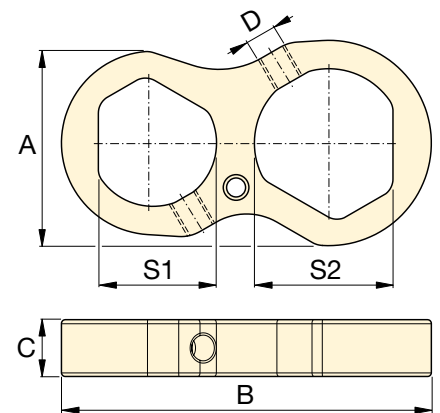

▼ Enerpac Back-Up Spanners to be used to stop back nut from turning during make up or break out.



▼ Shown: STTLS31055 Safe T™ Torque Lock



Hands-free torque wrench system



Safe T™ Torque Lock

The Safe T™ Torque Lock is suitable for all bolted applications from 190 Nm to 15.000 Nm using a heavy duty impact socket.

The patented mechanical locking system creates a hands-free torque wrench solution suitable for Enerpac only square drive tools.

Suitable for:

S-Series	RSQ-Series
S3000PX	RSQ3000
S6000PX	RSQ5000
S11000PX	RSQ11000

Safety – Safe T™ Torque Lock

- Transforming Enerpac S-Series & RSQ-Series wrenches into a dedicated hands-free tool
- Improves operator safety during bolting operations by minimizing exposure to pinch points and high pressure hydraulic connections
- Grips securely to the application in any orientation, including inverted positions
- Minimizes drop hazards of falling tools
- Reduces operator fatigue on overreaching or awkward positioning of the tool.

Simplicity

- With one twist of the locking collar the Safe T™ Torque Lock grips onto the application, firmly holding the full tool weight in place
- Assembles onto the torque wrench with one push of the square drive quick release button for tightening or loosening
- Locking feature reduces the number of tool lifts dramatically.

Versatility

- Suitable for both S-Series & RSL-Series square drive wrenches
- Simple twist & lock mechanism is user friendly, easy to operate
- No additional loose components like reaction washers are needed.



▲ Hands-free torque wrench system: STLLS-model with S-Series torque wrench. The square drive of the wrench can easily be exchanged by the Safe T™ Torque Lock model.



Back-Up Spanners, BUS-Series

To be used to stop back nut from turning during make up or break out. Two hexagon sizes in one tool.

Safe T™ Torque Lock – Hands-free torque wrench system



Common Torque Lock Applications:

- Oil & Gas flanges
- Tower Crane installation
- Machine installation/assembly (Mining),
- Wind Tower installation etc.

Industries

- Oil & Gas, Petrochemical
- Wind Power Generation
- Mining
- Marine
- Manufacturing
- Rail and more

STTL Series



Hexagon Range (A/F):

46 - 75 mm

Hexagon Range (A/F):

1 13/16 - 3 1/8 inch

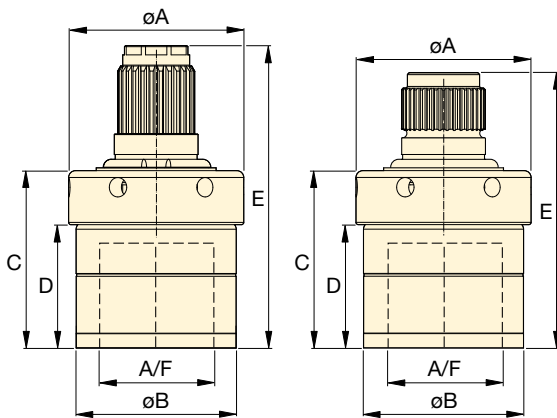

STTLS for S-Series Spline Fitting

STTLR for RSQ-Series Spline Fitting



IMPORTANT:
Safe T™ Torque Lock not suitable for use on PTFE coated nuts.



Bolting Integrity Software

Enerpac Bolting Integrity Software Solutions play a key role in

implementing and managing an Integrity Program for bolted connections.

The software offers Tool selection, Bolt Load calculations and Tool pressure settings, as well as, a combined Application Data Sheet and Joint Completion Report. Custom Joint information can also be entered.

Page: 422

Hexagon Sizes A/F		For use with torque wrench model	Safe T™ Torque Lock Model Number		Dimensions (inch)					⚖️ (lbs)	Dimensions (mm)					⚖️ (kg)
(inch)	(mm)		For S-Series Spline Fitting	For RSQ-Series Spline Fitting	A	B	C	D	E		A	B	C	D	E	
1 13/16	46	S3000PX	STTLS31046	-	3.0	2.8	3.1	2.1	5.2	4.4	77	71	78	54	133	2.0
		RSQ3000	-	STTLR31046					4.8	4.2					121	1.9
2	50	S3000PX	STTLS31550	-	3.5	3.2	3.1	2.1	5.2	5.7	89	82	78	54	133	2.6
		RSQ3000	-	STTLR31550					4.8	5.7					123	2.6
2 3/16	55	S3000PX	STTLS31055	-	3.7	3.4	3.3	2.3	5.4	6.6	93	86	83	58	138	3.0
		RSQ3000	-	STTLR31055					5.1	6.4					130	2.9
2 3/8	-	RSQ3000	-	STTLR315238	3.9	3.6	3.6	2.6	5.4	7.7	99	92	91	67	136	3.5
2	50	RSQ5000	-	STTLR51550	3.5	3.2	3.1	2.1	5.2	5.9	89	82	78	54	132	2.7
		S6000PX	STTLS61560M	-					5.9	8.2					150	3.7
-	60	RSQ5000	-	STTLR51560M	3.9	3.6	3.4	2.5	5.7	8.2	99	92	86	62	145	3.7
		S6000PX	STTLS615238	-					6.0	8.4					154	3.8
2 3/8	-	RSQ5000	-	STTLR515238	3.9	3.6	3.6	2.6	5.9	8.4	99	92	91	67	150	3.8
		S6000PX	STTLS61565	-					6.8	11.7					172	5.3
2 9/16	65	RSQ5000	-	STTLR51565	4.2	3.9	4.2	2.9	6.6	11.9	107	100	108	74	168	5.4
		S6000PX	STTLS61570	-					6.8	13.0					173	5.9
2 3/4	70	RSQ5000	-	STTLR51570	4.5	4.2	4.3	3.0	6.7	13.2	114	107	109	76	169	6.0
		S6000PX	STTLS61575	-					7.0	12.3					177	5.6
2 15/16	75	RSQ5000	-	STTLR51575	4.4	4.1	4.4	3.1	6.9	13.2	112	105	113	80	173	5.8
		S6000PX	STTLS111560M	-					6.6	9.3					167	4.2
-	60	RSQ11000	-	STTLR111560M	3.9	3.6	3.4	2.5	6.1	9.3	99	92	86	62	156	4.2
		S11000PX	STTLS111565	-					7.5	12.8					189	5.8
2 9/16	65	RSQ11000	-	STTLR111565	4.2	3.9	4.2	2.9	7.0	12.8	107	100	107	74	178	5.8
		S11000PX	STTLS111570	-					7.5	14.1					191	6.4
2 3/4	70	RSQ11000	-	STTLR111570	4.5	4.2	4.3	3.0	7.1	14.3	114	107	109	76	181	6.5
		S11000PX	STTLS111575	-					7.7	13.2					195	6.0
2 15/16	75	RSQ11000	-	STTLR111575	4.4	4.1	4.4	3.1	7.2	13.2	112	105	113	80	183	6.0
		S11000PX	STTLS1115318	-					7.8	16.1					197	7.3
3 1/8	-	RSQ11000	-	STTLR1115318	4.8	4.5	4.5	3.2	7.3	16.3	122	115	115	81	197	7.3
		S11000PX	STTLS1115318	-					7.8	16.1					197	7.3

W-Series, Low Profile Hexagon Torque Wrenches **ENERPAC**

▼ Shown: W4206X hexagon cassette with W4000PX drive unit



Safety and Performance

- Superior strength to size ratio provides easy access to difficult to reach applications without sacrificing endurance
- 30° rotation angle and rapid return stroke provide fast operation
- Tough manifold design with added safety feature for enhanced operator safety.

Simplicity

- Fast release drive unit enables rapid exchange of cassettes, no tools required
- Quick and easy disassembly for maintenance without special tools
- Drive units include robust handle which mounts on both sides of cassettes to allow for extra maneuverability.

Versatility

- Available with optional enhanced tilt and swivel TSP300 manifold for horizontal and vertical maneuverability, with greater durability ¹⁾
- X-Edition drive units, cassettes and most accessories are compatible with standard edition tools ¹⁾
- Drive unit compatible with UltraSlim W-SL cassettes.

Accuracy

- Constant torque output provides accuracy of $\pm 3\%$ across full stroke.

¹⁾ TSP300 is designed for X-Edition tools only, and is not compatible with previous edition tools. For replacement components for existing tools, refer to repair sheet on www.enerpac.com



Two Handle Styles

Robust angled positioning handle comes standard with every W-Series (X-Edition) drive unit.

Compatible with W-Series (X-Edition) Cassettes	Model Nr. Angled positioning handles (standard)	Model Nr. Straight positioning handles (optional)
W2000PX, W4000PX	SWH6A	SWH6S
W8000PX, W15000PX	SWH10A	SWH10S
W22000PX, W35000PX	SWH10EA ²⁾	

²⁾ SWH10EA is an eyebolt handle.



TSP300 Tilt & swivel manifold

Standard TSP300 tilt and swivel manifold with robust interlocking design provides 360° X-axis rotation and 160° Y-axis rotation.

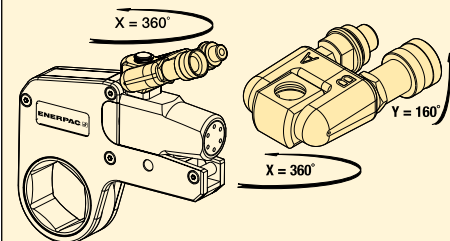

ATEX declared. Calibration certificate included

All W-Series X-edition hexagon cassettes are CE - ATEX declared and are shipped complete with a calibration certificate.



Back-Up Spanners

To be used to stop the back nut from turning during make up or break out. Two hexagon sizes in one tool.

Double-Acting Hydraulic Hexagon Torque Wrenches, X-Edition

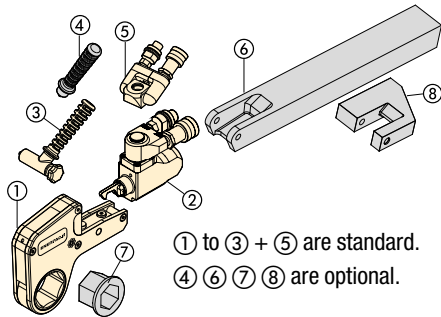

- ① Hexagon Cassette (pages 230-237)
 - ② Drive Unit (page 229)
 - ③ Angled Positioning Handle (page 228)
 - ④ Straight Positioning Handle (page 228)
 - ⑤ Pro Series Swivel
 - ⑥ Extended Reaction Arm (page 240)
 - ⑦ Reducer Insert (pages 230-237)
 - ⑧ Reaction Paddle (page 240)
- ① to ③ + ⑤ are standard.
④ ⑥ ⑦ ⑧ are optional.

W Series X-Edition



Nominal Torque at 690 bar:

47.454 Nm

Hexagon Range:

30 - 155 mm / 1 1/16 - 6 1/8"

Nose Radius:

31 - 115 mm

Maximum Operating Pressure:

690 bar

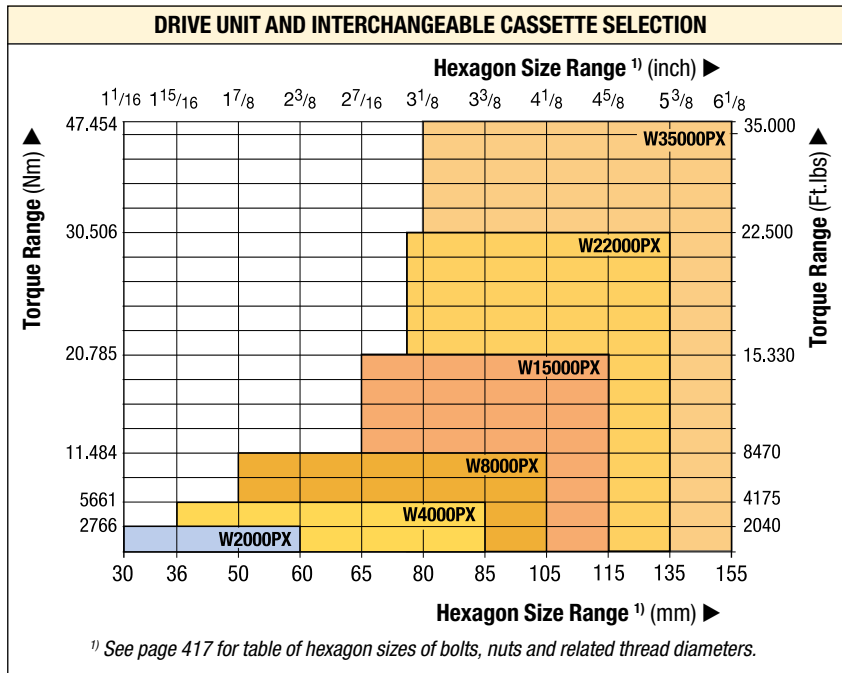

Torque Pump Selection Matrix

For optimum speed and performance see the torque wrench, pump and hoses matrix.

Page: **273**

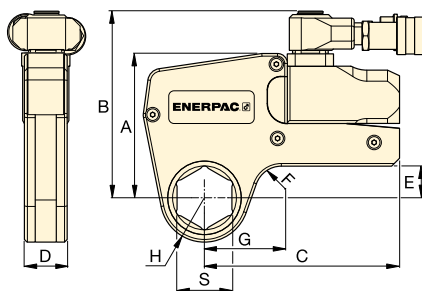

These rigid steel wrenches with low profile interchangeable hexagon cassettes guarantee durability and maximum versatility in bolting applications. ▶



▼ SELECTION CHART

Hexagon Range *		Nominal Torque at 690 bar		Drive Unit Model Number **	Minimum Torque at 69 bar		Dimensions (mm) (see pages 230-237 for dimensions G, H and S)						Weight (drive unit without hexagon cassette) (kg)
(mm)	(inch)	(Nm)	(Ft.lbs)		(Nm)	(Ft.lbs)	A	B	C	D	E	F	
30 - 60	1 1/16 - 2 3/8	2766	2040	W2000PX	276	204	109	141	148	32	24	20	1,4
36 - 85	1 5/16 - 3 3/8	5661	4175	W4000PX	566	417	136	167	178	41	33	20	2,0
50 - 105	1 7/8 - 4 1/8	11.484	8470	W8000PX	1148	847	172	205	208	53	42	25	3,0
65 - 115	2 7/16 - 4 5/8	20.785	15.330	W15000PX	2078	1533	207	240	253	63	50	20	5,0
75 - 135	2 15/16 - 5 3/8	30.506	22.500	W22000PX	3050	2250	227	266	297	77	48	35	7,7
80 - 155	3 1/8 - 6 1/8	47.454	35.000	W35000PX	4745	3500	268	301	345	91	69-73	50	11,4

* With in-line reaction foot.

** To order a W-series wrench without the TSP swivel, remove suffix "P" from the model number. Example: **W2000PX**.

www.enerpac.com

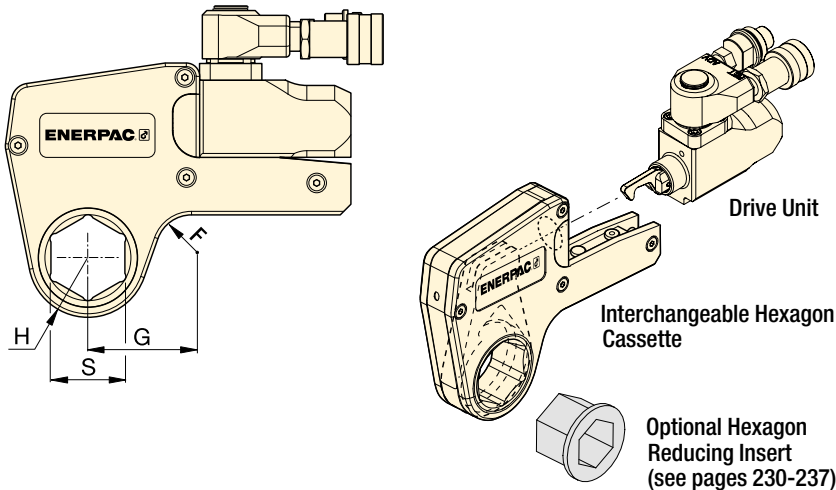

W Series X-Edition



Nominal Torque at 690 bar:

2766 Nm

Hexagon Range:

1¹/₁₆ - 2³/₈ inch

Maximum Operating Pressure:

690 bar



Metric Sizes

For metric sizes of hexagon cassettes and reducer inserts see:

Page: **236**



Hexagon Bolt and Nut Sizes

See the table for hexagon sizes of bolts, nuts and related thread diameters.

Page: **417**

▼ SELECTION CHART

Drive Unit Model Number	Hexagon Size ¹⁾	Nose Radius	Dim.	Model Number	Weight (kg)	Hexagon Reducer		Hexagon Reducer		Hexagon Reducer	
						Hexagon Reducer (inch)	Model Number	Hexagon Reducer (inch)	Model Number	Hexagon Reducer (inch)	Model Number
W2000PX	1 ¹ / ₁₆	31,0	53,7	W2101X	2,1	-	-	-	-	-	-
	1 ¹ / ₈	31,0	53,7	W2102X	2,1	-	-	-	-	-	-
	1 ³ / ₁₆	31,0	53,7	W2103X	2,1	-	-	-	-	-	-
	1 ¹ / ₄	31,0	53,7	W2104X	2,1	-	-	-	-	-	-
	1 ⁵ / ₁₆	31,0	53,7	W2105X	2,1	-	-	-	-	-	-
	1 ³ / ₈	31,0	53,7	W2106X	2,1	-	-	-	-	-	-
	1 ⁷ / ₁₆	31,0	53,7	W2107X	2,1	1 ⁷ / ₁₆ - 1 ¹ / ₈	W2107R102	-	-	-	-
	1 ¹ / ₂	33,5	58,2	W2108X	2,2	-	-	-	-	-	-
	1 ⁹ / ₁₆	33,5	58,2	W2109X	2,2	-	-	-	-	-	-
	1 ⁵ / ₈	33,5	58,2	W2110X	2,2	1 ⁵ / ₈ - 1 ¹ / ₄	W2110R104	1 ⁵ / ₈ - 1 ³ / ₁₆	W2110R103	-	-
	1 ¹¹ / ₁₆	36,5	60,5	W2111X	2,2	-	-	-	-	-	-
	1 ³ / ₄	36,5	60,5	W2112X	2,2	-	-	-	-	-	-
	1 ¹³ / ₁₆	36,5	60,5	W2113X	2,2	1 ¹³ / ₁₆ - 1 ⁷ / ₁₆	W2113R107	1 ¹³ / ₁₆ - 1 ¹ / ₄	W2113R104	-	-
	1 ⁷ / ₈	39,0	63,1	W2114X	2,2	-	-	-	-	-	-
	1 ¹⁵ / ₁₆	39,0	63,1	W2115X	2,2	-	-	-	-	-	-
	2	39,0	63,1	W2200X	2,2	2 - 1 ⁵ / ₈	W2200R110	2 - 1 ⁷ / ₁₆	W2200R107	-	-
	2 ¹ / ₁₆	41,8	68,6	W2201X	2,3	-	-	-	-	-	-
	2 ¹ / ₈	41,8	68,6	W2202X	2,3	-	-	-	-	-	-
	2 ³ / ₁₆	41,8	68,6	W2203X	2,3	2 ³ / ₁₆ - 1 ¹³ / ₁₆	W2203R113	2 ³ / ₁₆ - 1 ⁵ / ₈	W2203R110	2 ³ / ₁₆ - 1 ⁷ / ₁₆	W2203R107
	2 ¹ / ₄	44,5	64,8	W2204X	2,2	-	-	-	-	-	-
2 ⁵ / ₁₆	44,5	64,8	W2205X	2,2	-	-	-	-	-	-	
2 ³ / ₈	44,5	64,8	W2206X	2,2	2 ³ / ₈ - 2	W2206R200	2 ³ / ₈ - 1 ⁷ / ₈	W2206R114	2 ³ / ₈ - 1 ¹³ / ₁₆	W2206R113	
-	-	-	-	-	-	2 ³ / ₈ - 1 ¹ / ₂	W2206R108	2 ³ / ₈ - 1 ⁷ / ₁₆	W2206R107	2 ³ / ₈ - 1 ⁵ / ₁₆	W2206R110

¹⁾ See page 417 for table of hexagon sizes of bolts, nuts and related thread diameters.

W4000X-Series, Inch-Cassettes & Reducer Inserts

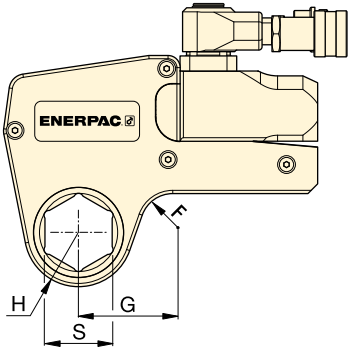

Nominal Torque at 690 bar:

5661 Nm

Hexagon Range:

1⁵/₁₆ - 3³/₈ inch

Maximum Operating Pressure:

690 bar

W
Series
X-Edition



Drive Unit Model Number	Hexagon Size ¹⁾	Nose Radius	Dim.	Model Number	Weight	Hexagon Reducer		Hexagon Reducer		Hexagon Reducer	
						Hexagon Reducer (inch)	Model Number	Hexagon Reducer (inch)	Model Number	Hexagon Reducer (inch)	Model Number
W4000PX	1 ⁵ / ₁₆	37,0	61,0	W4105X	3,7	-	-	-	-	-	-
	1 ³ / ₈	37,0	61,0	W4106X	3,7	-	-	-	-	-	-
	1 ⁷ / ₁₆	37,0	61,0	W4107X	3,7	-	-	-	-	-	-
	1 ¹ / ₂	37,0	61,0	W4108X	3,7	-	-	-	-	-	-
	1 ⁹ / ₁₆	37,0	61,0	W4109X	3,7	-	-	-	-	-	-
	1 ⁵ / ₈	37,0	61,0	W4110X	3,7	-	-	-	-	-	-
	1 ¹¹ / ₁₆	39,5	64,0	W4111X	3,8	-	-	-	-	-	-
	1 ³ / ₄	39,5	64,0	W4112X	3,8	-	-	-	-	-	-
	1 ¹³ / ₁₆	39,5	64,0	W4113X	3,8	-	-	-	-	-	-
	1 ⁷ / ₈	41,5	66,7	W4114X	3,9	-	-	-	-	-	-
	1 ¹⁵ / ₁₆	41,5	66,7	W4115X	3,9	-	-	-	-	-	-
	2	41,5	66,7	W4200X	3,9	2 - 1 ⁷ / ₁₆	W4200R107	-	-	-	-
	2 ¹ / ₁₆	44,0	73,4	W4201X	4,0	-	-	-	-	-	-
	2 ¹ / ₈	44,0	73,4	W4202X	4,0	-	-	-	-	-	-
	2 ³ / ₁₆	44,0	73,4	W4203X	4,0	2 ³ / ₁₆ - 1 ⁵ / ₈	W4203R110	2 ³ / ₁₆ - 1 ⁷ / ₁₆	W4203R107	2 ³ / ₁₆ - 1 ¹ / ₄	W4203R104
	2 ¹ / ₄	46,5	70,6	W4204X	4,1	-	-	-	-	-	-
	2 ⁵ / ₁₆	46,5	70,6	W4205X	4,1	-	-	-	-	-	-
	2 ³ / ₈	46,5	70,6	W4206X	4,1	2 ³ / ₈ - 2	W4206R200	2 ³ / ₈ - 1 ¹³ / ₁₆	W4206R113	2 ³ / ₈ - 1 ⁷ / ₁₆	W4206R107
	-	-	-	-	-	2 ³ / ₈ - 1 ³ / ₈	W4206R106	-	-	-	-
	2 ⁷ / ₁₆	49,5	76,2	W4207X	4,1	2 ⁷ / ₁₆ - 2	W4207R200	-	-	-	-
	2 ¹ / ₂	49,5	76,2	W4208X	4,1	2 ¹ / ₂ - 2	W4208R200	2 ¹ / ₂ - 1 ⁷ / ₁₆	W4208R113	2 ¹ / ₂ - 2 ¹ / ₁₆	W4208R201
	2 ⁹ / ₁₆	49,5	76,2	W4209X	4,1	2 ⁹ / ₁₆ - 2 ³ / ₁₆	W4209R203	2 ⁹ / ₁₆ - 2 ¹ / ₈	W4209R202	2 ⁹ / ₁₆ - 2 ¹ / ₁₆	W4209R201
	-	-	-	-	-	2 ⁹ / ₁₆ - 2	W4209R200	2 ⁹ / ₁₆ - 1 ¹³ / ₁₆	W4209R113	-	-
	2 ⁵ / ₈	52,5	78,3	W4210X	4,2	-	-	-	-	-	-
	2 ¹¹ / ₁₆	52,5	78,3	W4211X	4,2	-	-	-	-	-	-
	2 ³ / ₄	52,5	78,3	W4212X	4,2	2 ³ / ₄ - 2 ³ / ₈	W4212R206	2 ³ / ₄ - 2 ³ / ₁₆	W4212R203	2 ³ / ₄ - 2 ¹ / ₈	W4212R202
	2 ¹³ / ₁₆	55,3	81,6	W4213X	4,3	-	-	-	-	-	-
	2 ⁷ / ₈	55,3	81,6	W4214X	4,3	-	-	-	-	-	-
	2 ¹⁵ / ₁₆	55,3	81,6	W4215X	4,3	2 ¹⁵ / ₁₆ - 2 ⁹ / ₁₆	W4215R209	2 ¹⁵ / ₁₆ - 2 ³ / ₈	W4215R206	2 ¹⁵ / ₁₆ - 2 ³ / ₁₆	W4215R203
	-	-	-	-	-	2 ¹⁵ / ₁₆ - 2	W4215R200	-	-	-	-
	3	58,5	83,5	W4300X	4,4	3 - 2 ⁹ / ₁₆	W4300R203	-	-	-	-
	3 ¹ / ₁₆	58,5	83,5	W4301X	4,4	-	-	-	-	-	-
	3 ¹ / ₈	58,5	83,5	W4302X	4,4	3 ¹ / ₈ - 2 ³ / ₄	W4302R212	3 ¹ / ₈ - 2 ⁹ / ₁₆	W4302R209	3 ¹ / ₈ - 2 ³ / ₈	W4302R206
	-	-	-	-	-	3 ¹ / ₈ - 2 ⁵ / ₁₆	W4302R205	3 ¹ / ₈ - 2 ¹ / ₄	W4302R204	3 ¹ / ₈ - 2 ³ / ₁₆	W4302R203
	-	-	-	-	-	3 ¹ / ₈ - 2 ³ / ₁₆	W4302R203	3 ¹ / ₈ - 2 ¹ / ₈	W4302R202	3 ¹ / ₈ - 2	W4302R200
	3 ³ / ₁₆	62,0	85,5	W4303X	4,5	-	-	-	-	-	-
3 ¹ / ₄	62,0	85,5	W4304X	4,5	-	-	-	-	-	-	
3 ⁵ / ₁₆	62,0	85,5	W4305X	4,5	-	-	-	-	-	-	
3 ³ / ₈	62,0	85,5	W4306X	4,5	-	-	-	-	-	-	

¹⁾ See page 417 for table of hexagon sizes of bolts, nuts and related thread diameters.

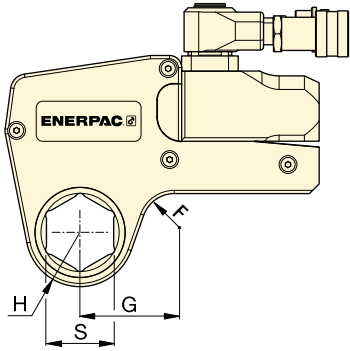

Nominal Torque at 690 bar:

11.484 Nm

Hexagon Range:

1⁷/₈ - 4¹/₈ inch

Maximum Operating Pressure:

690 bar

W
Series
X-Edition



▼ SELECTION CHART

Drive Unit Model Number	Hexagon Size ¹⁾	Nose Radius	Dim.	Model Number	Weight (kg)	Hexagon Reducer		Hexagon Reducer		Hexagon Reducer	
						Hexagon Reducer (inch)	Model Number	Hexagon Reducer (inch)	Model Number	Hexagon Reducer (inch)	Model Number
W8000PX	1 ⁷ / ₈	45,0	78,2	W8114X	8,1	–	–	–	–	–	–
	1 ¹⁵ / ₁₆	45,0	78,2	W8115X	8,1	–	–	–	–	–	–
	2	45,0	78,2	W8200X	8,1	–	–	–	–	–	–
	2 ¹ / ₁₆	48,0	80,0	W8201X	8,1	–	–	–	–	–	–
	2 ¹ / ₈	48,0	80,0	W8202X	8,1	–	–	–	–	–	–
	2 ³ / ₁₆	48,0	80,0	W8203X	8,1	–	–	–	–	–	–
	2 ¹ / ₄	51,0	82,5	W8204X	8,1	–	–	–	–	–	–
	2 ⁵ / ₁₆	51,0	82,5	W8205X	8,1	–	–	–	–	–	–
	2 ³ / ₈	51,0	82,5	W8206X	8,1	–	–	–	–	–	–
	2 ⁷ / ₁₆	52,5	85,9	W8207X	8,1	–	–	–	–	–	–
	2 ¹ / ₂	52,5	85,9	W8208X	8,1	–	–	–	–	–	–
	2 ⁹ / ₁₆	52,5	85,9	W8209X	8,1	2 ⁹ / ₁₆ - 2	W8209R200	–	–	–	–
	2 ⁵ / ₈	56,0	84,8	W8210X	8,1	–	–	–	–	–	–
	2 ¹¹ / ₁₆	56,0	84,8	W8211X	7,9	–	–	–	–	–	–
	2 ³ / ₄	56,0	84,8	W8212X	7,9	2 ³ / ₄ - 2 ³ / ₁₆	W8212R203	–	–	–	–
	2 ¹³ / ₁₆	58,0	85,0	W8213X	7,9	–	–	–	–	–	–
	2 ⁷ / ₈	58,0	85,0	W8214X	7,9	–	–	–	–	–	–
	2 ¹⁵ / ₁₆	58,0	85,0	W8215X	7,9	2 ¹⁵ / ₁₆ - 2 ³ / ₈	W8215R206	2 ¹⁵ / ₁₆ - 2 ³ / ₁₆	W8215R203	–	–
	3	60,5	89,5	W8300X	8,0	–	–	–	–	–	–
	3 ¹ / ₁₆	60,5	89,5	W8301X	8,0	–	–	–	–	–	–
	3 ¹ / ₈	60,5	89,5	W8302X	8,0	3 ¹ / ₈ - 2 ⁹ / ₁₆	W8302R209	3 ¹ / ₈ - 2 ³ / ₈	W8302R206	3 ¹ / ₈ - 2 ⁹ / ₁₆	W8302R203
	–	–	–	–	–	3 ¹ / ₈ - 2	W8302R200	–	–	–	–
	3 ³ / ₁₆	66,0	92,2	W8303X	8,2	–	–	–	–	–	–
	3 ¹ / ₄	66,0	92,2	W8304X	8,2	–	–	–	–	–	–
	3 ⁵ / ₁₆	66,0	92,2	W8305X	8,2	–	–	–	–	–	–
	3 ³ / ₈	66,0	92,2	W8306X	8,2	–	–	–	–	–	–
	3 ⁷ / ₁₆	66,0	92,2	W8307IX	8,2	–	–	–	–	–	–
	3 ¹ / ₂	66,0	92,2	W8308X	8,2	3 ¹ / ₂ - 3	W8308R300	3 ¹ / ₂ - 2 ¹⁵ / ₁₆	W8308R215	3 ¹ / ₂ - 2 ³ / ₄	W8308R212
	3 ⁹ / ₁₆	74,0	102,9	W8309X	8,8	–	–	–	–	–	–
	3 ⁵ / ₈	74,0	102,9	W8310X	8,8	–	–	–	–	–	–
	3 ¹¹ / ₁₆	74,0	102,9	W8311X	8,8	–	–	–	–	–	–
	3 ³ / ₄	74,0	102,9	W8312X	8,8	3 ³ / ₄ - 3 ¹ / ₈	W8312R302	3 ³ / ₄ - 2 ¹⁵ / ₁₆	W8312R215	3 ³ / ₄ - 2 ³ / ₄	W8312R212
3 ¹³ / ₁₆	74,0	102,9	W8313X	8,8	–	–	–	–	–	–	
3 ⁷ / ₈	74,0	102,9	W8314X	8,8	3 ⁷ / ₈ - 3 ¹ / ₈	W8314R302	3 ⁷ / ₈ - 2 ¹⁵ / ₁₆	W8314R215	–	–	
3 ¹⁵ / ₁₆	79,5	110,0	W8315X	9,3	–	–	–	–	–	–	
4	79,5	110,0	W8400X	9,3	–	–	–	–	–	–	
4 ¹ / ₁₆	79,5	110,0	W8401IX	9,3	–	–	–	–	–	–	
4 ¹ / ₈	79,5	110,0	W8402X	9,3	–	–	–	–	–	–	

¹⁾ See page 417 for table of hexagon sizes of bolts, nuts and related thread diameters.

W15000X-Series, Inch-Cassettes & Reducer Inserts

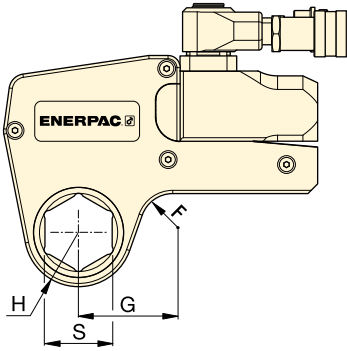

Nominal Torque at 690 bar:

20.785 Nm

Hexagon Range:

2¹/₈ - 4⁵/₈ inch

Maximum Operating Pressure:

690 bar

W
Series
X-Edition



▼ SELECTION CHART

Drive Unit Model Number	Hexagon Size ¹⁾	Nose Radius	Dim.	Model Number	Weight	Hexagon Reducer		Hexagon Reducer		Hexagon Reducer	
						Hexagon Reducer (inch)	Model Number	Hexagon Reducer (inch)	Model Number	Hexagon Reducer (inch)	Model Number
W15000PX	S (inch)	H (mm)	G (mm)		(kg)						
	2 ⁷ / ₁₆	59,0	88,6	W15207X	13,6	-	-	-	-	-	-
	2 ¹ / ₂	59,0	88,6	W15208X	13,6	-	-	-	-	-	-
	2 ⁹ / ₁₆	59,0	88,6	W15209X	13,6	-	-	-	-	-	-
	2 ⁵ / ₈	59,0	88,6	W15210X	13,6	-	-	-	-	-	-
	2 ¹¹ / ₁₆	59,0	88,6	W15211X	13,6	-	-	-	-	-	-
	2 ³ / ₄	59,0	88,6	W15212X	13,6	-	-	-	-	-	-
	2 ¹³ / ₁₆	62,0	90,5	W15213X	13,7	-	-	-	-	-	-
	2 ⁷ / ₈	62,0	90,5	W15214X	13,7	-	-	-	-	-	-
	2 ¹⁵ / ₁₆	62,0	90,5	W15215X	13,7	-	-	-	-	-	-
	3	64,5	92,9	W15300X	13,8	3 - 2 ¹ / ₈	W15300R202	-	-	-	-
	3 ¹ / ₁₆	64,5	92,9	W15301X	13,8	-	-	-	-	-	-
	3 ¹ / ₈	64,5	92,9	W15302X	13,8	3 ¹ / ₈ - 2 ⁹ / ₁₆	W15302R209	-	-	-	-
	3 ³ / ₁₆	69,5	96,6	W15303X	14,1	-	-	-	-	-	-
	3 ¹ / ₄	69,5	96,6	W15304X	14,1	-	-	-	-	-	-
	3 ⁵ / ₁₆	69,5	96,6	W15305X	14,1	-	-	-	-	-	-
	3 ³ / ₈	69,5	96,6	W15306X	14,1	-	-	-	-	-	-
	3 ⁷ / ₁₆	69,5	96,6	W15307IX	14,1	-	-	-	-	-	-
	3 ¹ / ₂	69,5	96,6	W15308X	14,1	3 ¹ / ₂ - 2 ¹⁵ / ₁₆	W15308R215	3 ¹ / ₂ - 2 ³ / ₄	W15308R212	-	-
	3 ⁹ / ₁₆	75,0	101,8	W15309X	14,6	-	-	-	-	-	-
	3 ⁵ / ₈	75,0	101,8	W15310X	14,6	-	-	-	-	-	-
	3 ¹¹ / ₁₆	75,0	101,8	W15311X	14,6	-	-	-	-	-	-
	3 ³ / ₄	75,0	101,8	W15312X	14,6	3 ³ / ₄ - 3 ¹ / ₈	W15312R302	3 ³ / ₄ - 2 ¹⁵ / ₁₆	W15312R215	-	-
	3 ¹³ / ₁₆	75,0	101,8	W15313X	14,5	-	-	-	-	-	-
	3 ⁷ / ₈	75,0	101,8	W15314X	14,5	3 ⁷ / ₈ - 3 ¹ / ₈	W15314R302	3 ⁷ / ₈ - 2 ¹⁵ / ₁₆	W15314R215	-	-
	3 ¹⁵ / ₁₆	80,5	103,1	W15315X	14,8	-	-	-	-	-	-
	4	80,5	103,1	W15400X	14,8	-	-	-	-	-	-
	4 ¹ / ₁₆	80,5	103,1	W15401IX	14,8	-	-	-	-	-	-
	4 ¹ / ₈	80,5	103,1	W15402X	14,8	4 ¹ / ₈ - 3 ¹ / ₂	W15402R308	4 ¹ / ₈ - 3 ⁵ / ₁₆	W15402R305	4 ¹ / ₈ - 3 ¹ / ₄	W15402R304
	4 ³ / ₁₆	80,5	103,1	W15403IX	14,8	-	-	-	-	-	-
	4 ¹ / ₄	80,5	103,1	W15404X	14,8	4 ¹ / ₄ - 3 ¹ / ₂	W15404R308	4 ¹ / ₄ - 3 ¹ / ₈	W15404R302	-	-
	4 ⁵ / ₁₆	87,5	114,8	W15405X	15,1	-	-	-	-	-	-
4 ³ / ₈	87,5	114,8	W15406X	15,1	-	-	-	-	-	-	
4 ⁷ / ₁₆	87,5	114,8	W15407X	15,1	-	-	-	-	-	-	
4 ¹ / ₂	87,5	114,8	W15408IX	15,1	-	-	-	-	-	-	
4 ⁹ / ₁₆	87,5	114,8	W15409IX	15,1	-	-	-	-	-	-	
4 ⁵ / ₈	87,5	114,8	W15410IX	15,1	4 ⁵ / ₈ - 3 ¹⁵ / ₁₆	W15410R315	4 ⁵ / ₈ - 3 ⁷ / ₈	W15410R314	4 ⁵ / ₈ - 3 ³ / ₄	W15410R312	
-	-	-	-	-	-	4 ⁵ / ₈ - 3 ¹ / ₂	W15410R308	-	-	-	
-	-	-	-	-	-	-	-	-	-	-	

¹⁾ See page 417 for table of hexagon sizes of bolts, nuts and related thread diameters.

W22000X, Inch-Cassettes & Reducers

ENERPAC 

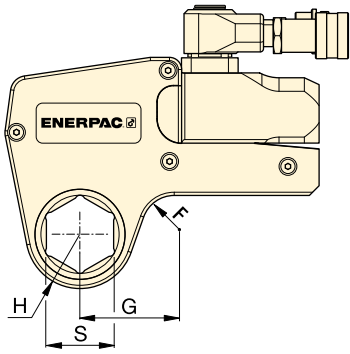

Nominal Torque at 690 bar:

30.506 Nm

Hexagon Range:

2¹⁵/₁₆ - 5³/₈ inch

Maximum Operating Pressure:

690 bar

W
Series
X-Edition



▼ **SELECTION CHART**

Drive Unit Model Number	Hexagon Size ¹⁾ S (inch)	Nose Radius H (mm)	G (mm)	Model Nr. Cassette	Weight (kg)	Hexagon Reducer		Hexagon Reducer		Hexagon Reducer	
						Hexagon Reducer (inch)	Model Number Reducer	Hexagon Reducer (inch)	Model Number Reducer	Hexagon Reducer (inch)	Model Number Reducer
W22000PX	2 ¹⁵ / ₁₆	67,0	102,1	W22215X	22,1	-	-	-	-	-	-
	3	67,0	102,1	W22300X	22,0	-	-	-	-	-	-
	3 ¹ / ₁₆	67,0	102,1	W22301X	21,9	-	-	-	-	-	-
	3 ¹ / ₈	67,0	102,1	W22302X	21,6	3 ¹ / ₈ - 2 ³ / ₈	W22302R206	3 ¹ / ₈ - 2 ³ / ₁₆	W22302R203	-	-
	3 ³ / ₁₆	72,4	107,4	W22303X	22,9	-	-	-	-	-	-
	3 ¹ / ₄	72,4	107,4	W22304X	22,8	-	-	-	-	-	-
	3 ⁵ / ₁₆	72,4	107,4	W22305X	22,6	-	-	-	-	-	-
	3 ³ / ₈	72,4	107,4	W22306X	22,5	-	-	-	-	-	-
	3 ⁷ / ₁₆	72,4	107,4	W22307IX	22,8	-	-	-	-	-	-
	3 ¹ / ₂	72,4	107,4	W22308X	22,2	3 ¹ / ₂ - 2 ³ / ₄	W22308R212	3 ¹ / ₂ - 2 ⁹ / ₁₆	W22308R209	3 ¹ / ₂ - 2 ³ / ₈	W22308R206
	3 ⁹ / ₁₆	77,9	113,0	W22309X	23,4	-	-	-	-	-	-
	3 ⁵ / ₈	77,9	113,0	W22310X	23,3	-	-	-	-	-	-
	3 ¹¹ / ₁₆	77,9	113,0	W22311X	23,1	-	-	-	-	-	-
	3 ³ / ₄	77,9	113,0	W22312X	22,9	3 ³ / ₄ - 2 ¹⁵ / ₁₆	W22312R215	-	-	-	-
	3 ¹³ / ₁₆	77,9	113,0	W22313X	22,8	-	-	-	-	-	-
	3 ⁷ / ₈	77,9	113,0	W22314X	22,6	3 ⁷ / ₈ - 3 ¹ / ₈	W22314R302	3 ⁷ / ₈ - 2 ¹⁵ / ₁₆	W22314R215	3 ⁷ / ₈ - 2 ³ / ₄	W22314R212
	3 ¹⁵ / ₁₆	85,1	119,9	W22315X	24,3	-	-	-	-	-	-
	4	85,1	119,9	W22400X	24,1	-	-	-	-	-	-
	4 ¹ / ₁₆	85,1	119,9	W22401IX	24,0	-	-	-	-	-	-
	4 ¹ / ₈	85,1	119,9	W22402X	23,6	-	-	-	-	-	-
	4 ³ / ₁₆	85,1	119,9	W22403IX	23,6	-	-	-	-	-	-
	4 ¹ / ₄	85,1	119,9	W22404X	24,6	4 ¹ / ₄ - 3 ¹ / ₂	W22404R308	4 ¹ / ₄ - 3 ¹ / ₈	W22404R302	4 ¹ / ₄ - 2 ¹⁵ / ₁₆	W22404R215
	4 ⁵ / ₁₆	89,9	125,0	W22405X	24,6	-	-	-	-	-	-
	4 ³ / ₈	89,9	125,0	W22406X	24,5	-	-	-	-	-	-
	4 ⁷ / ₁₆	89,9	125,0	W22407X	24,3	-	-	-	-	-	-
	4 ¹ / ₂	89,9	125,0	W22408IX	24,1	-	-	-	-	-	-
	4 ⁹ / ₁₆	89,9	125,0	W22409IX	23,9	-	-	-	-	-	-
	4 ⁵ / ₈	89,9	125,0	W22410IX	23,6	4 ⁵ / ₈ - 3 ⁷ / ₈	W22410R314	4 ⁵ / ₈ - 3 ³ / ₄	W22410R312	4 ⁵ / ₈ - 3 ¹ / ₂	W22410R308
	4 ³ / ₄	95,0	130,0	W22412X	24,7	-	-	-	-	-	-
	4 ⁷ / ₈	95,0	130,0	W22414X	24,3	-	-	-	-	-	-
	5	95,0	130,0	W22500X	23,8	5 - 4 ¹ / ₄	W22500R404	5 - 4 ¹ / ₈	W22500R402	5 - 3 ⁷ / ₈	W22500R314
	5 ¹ / ₈	100,0	134,8	W22502X	25,0	-	-	-	-	-	-
5 ³ / ₁₆	100,0	134,8	W22503IX	24,8	-	-	-	-	-	-	
5 ¹ / ₄	100,0	134,8	W22504IX	24,5	-	-	-	-	-	-	
5 ³ / ₈	100,0	134,8	W22506X	23,9	5 ³ / ₈ - 4 ⁵ / ₈	W22506R410	5 ³ / ₈ - 4 ¹ / ₄	W22506R404	5 ³ / ₈ - 4 ¹ / ₈	W22506R402	
-	-	-	W22506X	23,9	5 ³ / ₈ - 3 ⁷ / ₈	W22506R314	-	-	-	-	

¹⁾ See page 417 for table of hexagon sizes of bolts, nuts and related thread diameters.

W35000X, Inch-Cassettes & Reducer Inserts

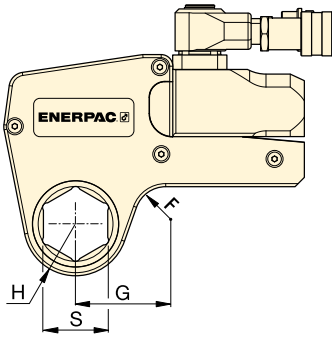

▼ SELECTION CHART

Drive Unit Model Number	Hexagon Size S	Nose Radius H	G	Model Nr. Cassette	Weight (kg)	Reducer	
						Hexagon Reducer (inch)	Model Number Reducer
W35000PX	3 1/8	76,0	126,8	W35302X	32,8	3 1/8 - 2	W35302R200
	3 3/16	76,0	126,8	W35303X	32,7	-	-
	3 1/4	76,0	126,8	W35304X	32,5	-	-
	3 5/16	76,0	126,8	W35305X	32,4	-	-
	3 3/8	76,0	126,8	W35306X	32,2	-	-
	3 7/16	76,0	126,8	W35307IX	32,0	-	-
	3 1/2	76,0	126,8	W35308X	31,8	3 1/2 - 2 5/16	W35308R205
	3 9/16	81,5	132,5	W35309X	32,4	-	-
	3 5/8	81,5	132,5	W35310X	33,3	-	-
	3 1 1/16	81,5	132,5	W35311X	33,1	-	-
	3 3/4	81,5	132,5	W35312X	32,9	-	-
	3 13/16	81,5	132,5	W35313X	32,7	-	-
	3 7/8	81,5	132,5	W35314X	32,4	3 7/8 - 2 1 1/16	W35314R211
	3 15/16	87,0	137,0	W35315X	34,1	3 15/16 - 2 13/16	W35315R213
	4	87,0	137,0	W35400X	33,9	-	-
	4 1/16	87,0	137,0	W35401IX	33,7	-	-
	4 1/8	87,0	137,0	W35402X	33,5	-	-
	4 3/16	87,0	137,0	W35403IX	33,3	-	-
	4 1/4	87,0	137,0	W35404X	33,0	4 1/4 - 3 1/16	W35404R301
	4 5/16	93,0	143,0	W35405X	34,9	-	-
	4 3/8	93,0	143,0	W35406X	34,7	-	-
	4 7/16	93,0	143,0	W35407X	34,5	-	-
	4 1/2	93,0	143,0	W35408IX	34,3	-	-
	4 9/16	93,0	143,0	W35409IX	34,1	-	-
	4 5/8	93,0	143,0	W35410IX	33,7	4 5/8 - 3 5/8	W35410R310
	4 3/4	98,5	148,5	W35412X	35,6	4 3/4 - 3 3/4	W35412R312
	4 7/8	98,5	148,5	W35414X	34,9	-	-
	5	98,5	148,5	W35500X	34,3	5 - 4	W35500R400
	5 1/8	103,0	153,0	W35502X	35,8	5 1/8 - 4 1/8	W35502R402
	5 3/16	103,0	153,0	W35503IX	35,6	-	-
	5 1/4	103,0	153,0	W35504IX	35,2	-	-
	5 3/8	103,0	153,0	W35506X	34,6	5 3/8 - 4 5/16	W35506R405
5 1/2	108,5	158,5	W35508X	36,2	-	-	
5 9/16	108,5	158,5	W35509X	36,0	-	-	
5 5/8	108,5	158,5	W35510X	35,6	-	-	
5 3/4	108,5	164,0	W35512X	34,9	5 3/4 - 4 3/4	W35512R412	
5 7/8	114,0	164,0	W35514X	36,7	5 7/8 - 4 7/8	W35514R414	
6	114,0	164,0	W35600X	36,1	-	-	
6 1/8	114,0	164,0	W35602X	35,3	6 1/8 - 5 1/8	W35602R502	

W Series X-Edition



Nominal Torque at 690 bar:

47.454 Nm

Hexagon Range:

3 1/8 - 6 1/8 inch

Maximum Operating Pressure:

690 bar



Hexagon Bolt and Nut Sizes

See the table for hexagon sizes of bolts, nuts and related thread diameters.

Page: 417



Back-Up Spanners

To be used to stop the back nut from turning during make up or break out. Two hexagon sizes in one tool.

Page: 225

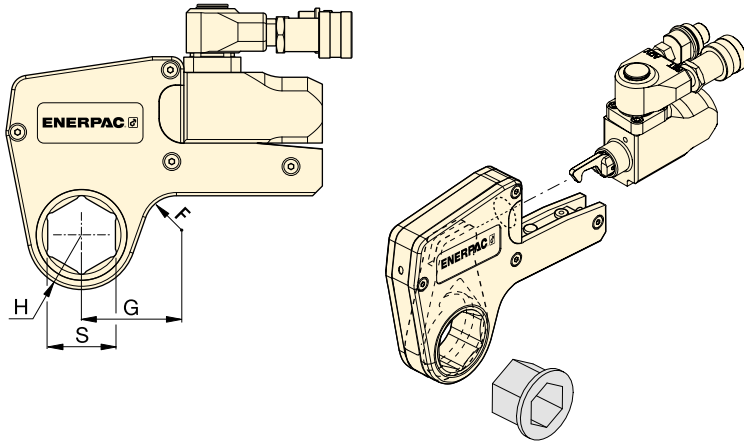

W
Series
X-Edition



Hexagon Range:

24 - 105 mm

Maximum Operating Pressure:

690 bar

▼ SELECTION CHART

Drive Unit Model Number	Hexagon Size ¹⁾	Nose Radius	Dim.	Model Nr. Cassette	Weight (kg)	Hexagon Reducer		Hexagon Reducer		Hexagon Reducer	
						Hexagon Reducer (mm)	Model Number Reducer	Hexagon Reducer (mm)	Model Number Reducer	Hexagon Reducer (mm)	Model Number Reducer
W2000PX (2766 Nm)	30	31,0	54	W2103X	2,1	-	-	-	-	-	-
	32	31,0	54	W2104X	2,1	-	-	-	-	-	-
	36	31,0	54	W2107X	2,1	-	-	-	-	-	-
	38	33,5	58	W2108X	2,2	-	-	-	-	-	-
	41	33,5	58	W2110X	2,2	41 - 32	W2110R104	41 - 30	W2110R103	41 - 24	W2110R024M
	46	33,5	61	W2113X	2,2	46 - 36	W2113R107	46 - 32	W2113R104	-	-
	50	39,0	63	W2200X	2,2	50 - 41	W2200R110	50 - 36	W2200R107	-	-
	55	41,8	69	W2203X	2,3	55 - 46	W2203R113	55 - 41	W2203R110	55 - 36	W2203R107
	60	44,5	65	W2206X	2,2	60 - 50	W2206R200	60 - 46	W2206R113	60 - 41	W2206R110
	-	-	-	-	-	-	60 - 36	W2206R107	-	-	-
W4000PX (5661 Nm)	36	37,0	61	W4107X	3,7	-	-	-	-	-	-
	41	37,0	61	W4110X	3,7	-	-	-	-	-	-
	46	39,5	64	W4113X	3,8	-	-	-	-	-	-
	50	41,5	67	W4200X	3,9	50 - 36	W4200R107	-	-	-	-
	55	44,0	73	W4203X	4,0	55 - 41	W4203R110	55 - 36	W4203R107	55 - 32	W4203R104
	60	46,5	71	W4206X	4,1	60 - 50	W4206R200	60 - 46	W4206R113	60 - 36	W4206R107
	65	49,5	76	W4209X	4,1	65 - 55	W4209R203	65 - 50	W4209R200	65 - 46	W4209R113
	70	52,5	78	W4212X	4,2	70 - 60	W4212R206	70 - 55	W4212R203	-	-
	75	55,3	82	W4215X	4,3	75 - 65	W4215R209	75 - 60	W4215R206	-	-
	-	-	-	W4215X	-	-	75 - 55	W4215R203	75 - 50	W4215R200	-
W8000PX (11.484 Nm)	80	58,5	84	W4302X	-	-	-	80 - 70	W4302R212	80 - 65	W4302R209
	-	-	-	W4302X	-	-	-	80 - 50	W4302R200	-	-
	85	62,0	86	W4085MX	4,5	-	-	-	-	-	-
	50	45,0	78	W8200X	8,1	-	-	-	-	-	-
	55	48,0	80	W8203X	8,1	-	-	-	-	-	-
	60	51,0	83	W8206X	8,1	-	-	-	-	-	-
	65	52,5	85	W8209X	8,1	65 - 50	W8209R200	-	-	-	-
	70	56,0	85	W8212X	7,9	70 - 55	W8212R203	-	-	-	-
	75	58,0	85	W8215X	7,9	75 - 60	W8215R206	75 - 55	W8215R203	-	-
	80	60,5	90	W8302X	8	80 - 65	W8302R209	80 - 60	W8302R206	80 - 55	W8302R203
-	-	-	-	-	-	80 - 50	W8302R200	-	-	-	
-	-	-	-	-	-	85 - 70	W8085R070M	85 - 65	W8085R065M	85 - 60	W8085R060M
-	-	-	-	-	-	85 - 55	W8085R055M	-	-	-	-
90	74,0	103	W8090MX	8,8	90 - 75	W8090R075M	-	-	-	-	
95	74,0	103	W8312X	8,8	95 - 80	W8312R302	95 - 75	W8312R215	-	-	
100	79,5	110	W8315X	9,3	-	-	-	-	-	-	
105	79,5	110	W8402X	9,3	-	-	-	-	-	-	

¹⁾ See page 417 for table of hexagon sizes of bolts, nuts and related thread diameters.

W-Series, Metric Cassettes and Reducers

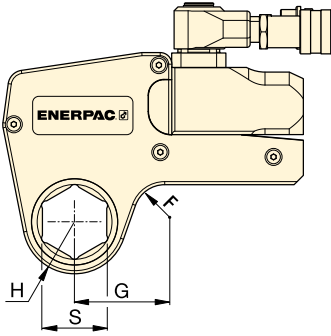

Hexagon Range:
50 - 155 mm

Maximum Operating Pressure:
690 bar

W
Series
X-Edition



▼ SELECTION CHART

Drive Unit Model Number	Hexagon Size ¹⁾	Nose Radius	Dim.	Model Nr. Cassette	Weight (kg)	Hexagon Reducer		Hexagon Reducer	
						Hexagon Reducer (mm)	Model Number Reducer	Hexagon Reducer (mm)	Model Number Reducer
W15000PX (20.785 Nm)	65	59,0	89	W15209X	13,6	-	-	-	-
	70	59,0	89	W15212X	13,6	-	-	-	-
	75	62,0	91	W15215X	13,7	-	-	-	-
	80	64,5	93	W15302X	13,8	80 - 65	W15302R209	-	-
	85	69,5	97	W15085MX	14,1	85 - 70	W15085R070M	-	-
	90	75,0	102	W15090MX	14,5	90 - 75	W15090R075M	-	-
	95	75,0	102	W15312X	14,6	95 - 80	W15312R302	95 - 75	W15312R215
	100	80,5	103	W15315X	14,8	-	-	-	-
	105	80,5	103	W15402X	14,8	105 - 90	W15402R090M	-	-
	110	87,5	115	W15405X	15,1	110 - 95	W15110R095M	-	-
	115	87,5	115	W15115MX	15,1	115 - 100	W15115R100M	-	-
W22000PX (30.506 Nm)	75	67,0	102	W22215X	22,0	-	-	-	-
	80	67,0	102	W22302X	21,6	80-60	W22302R206	80 - 55	W22302R203
	85	73,0	107	W22085MX	22,5	85-65	W22085MR209	85 - 60	W22085MR206
	90	77,9	113	W22090MX	23,4	90-70	W22090MR212	90 - 60	W22090MR206
	95	77,9	113	W22312X	22,9	95-75	W22312R215	-	-
	100	85,1	120	W22315X	24,3	-	-	-	-
	105	85,1	120	W22402X	23,4	-	-	-	-
	110	89,9	125	W22405X	24,6	-	-	-	-
	115	89,9	125	W22115MX	24,0	-	-	-	-
	120	95,0	130	W22412X	24,7	-	-	-	-
	123	95,0	130	W22123MX	24,4	-	-	-	-
W35000PX (47.454 Nm)	130	100,0	135	W22502X	25,0	-	-	-	-
	135	100,0	135	W22506X	23,9	135 - 105	W22506R402	-	-
	80	76,0	129	W35302X	32,8	80 - 50	W35302R200	-	-
	85	76,0	129	W35085MX	32,3	-	-	-	-
	90	81,5	135	W35090MX	33,5	90 - 60	W35090R206	-	-
	95	81,5	135	W35312X	32,9	-	-	-	-
	100	87,0	139	W35315X	34,1	-	-	-	-
	105	87,0	139	W35402X	33,5	-	-	-	-
	110	93,0	146	W35405X	34,9	110 - 85	W35405R085M	-	-
	115	93,0	146	W35115MX	34,2	-	-	-	-
	120	100,0	153	W35412X	35,6	120 - 95	W35412R312	-	-
	123	100,0	153	W35123MX	35,0	-	-	-	-
	130	103,0	160	W35502X	35,8	130 - 105	W35502R402	-	-
	135	103,0	160	W35506X	34,6	135 - 110	W35506R405	-	-
	140	110,0	163	W35508X	36,2	140 - 115	W35508R115M	-	-
	145	110,0	163	W35512X	34,9	145 - 120	W35512R412	-	-
	150	114,0	164	W35514X	36,7	-	-	-	-
151	114,0	164	W35151MX	36,5	-	-	-	-	
155	114,0	164	W35602X	35,3	155 - 130	W35602R502	-	-	

¹⁾ See page 417 for table of hexagon sizes of bolts, nuts and related thread diameters.

▼ W4206SL ultraslim bi-hexagonal stepped width cassette with W4000X drive unit



Your easy and long lasting solution to difficult access bolting applications



UltraSlim: Designed for Tight Spots

Stepped width design provides easy access in confined areas. UltraSlim cassettes fit where standard solutions won't.



Built to Outperform

High endurance components keep working when others fail.



Top Mounted Straight Handle

The top mounted straight handle is standard and provides safe and easy positioning and access to hard to reach fasteners.

Straight handle (standard)	SWH6S
Angled handle (optional)	SWH6A



ATEX declared. Calibration certificate included.

All UltraSlim Series cassettes are CE - ATEX declared and are shipped complete with a calibration certificate.



Versatility

- Lean, stepped width design allows tool to be mounted over bolts where other tools won't fit
- Bi-Hexagonal cassette allows twice as many positioning points on nut or bolt
- Robust top mounted handle stays out of the way, providing safe fastening in hard to reach areas
- Uses same drive unit as standard W-series hexagon cassettes.

Performance

- Premium components provide best-in-class endurance compared to other limited access tools.

Ease of Use

- Few moving parts are easily accessible for quick field maintenance
- Fast release drive unit enables rapid exchange of cassettes, no tools required
- Top mounted straight handle for improved tool handling and safety.

Accuracy

- Constant torque output provides accuracy of $\pm 3\%$ across the full stroke
- Calibration certificate shipped with every cassette.

Slim enough to fit and tough enough to last. This UltraSlim wrench is the perfect controlled bolting solution for this oil and gas flange. ▶



UltraSlim Bi-Hexagonal Cassettes



UltraSlim Cassettes

Accessing narrow spaces normally requires significantly reducing the width of the torque wrench. For the tool operator, this has always meant vastly reduced tool durability, and/or reduced torque output.

By using the highest grade materials, perfecting the geometry, and placing the positioning handle on top of the tool for safe fastening, Enerpac UltraSlim cassettes are able to provide greater torque, get into tighter spaces, and vastly outperform the competition in product durability*.

Durability of Key Components *

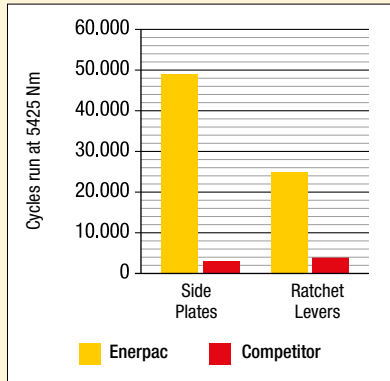

* Average test results, whereby three Enerpac 46 mm UltraSlim cassettes and three competitor 46 mm cassettes were tested at 5425 Nm for 50,000 cycles. The Enerpac side plates never broke for the full duration of the test.

W-SL Series UltraSlim



Nominal Torque Output:

5911 Nm

Bi-Hexagonal Range:

46 - 75 mm / 1¹³/₁₆ - 2¹⁵/₁₆"

Maximum Operating Pressure:

690 bar



Torque Pump Selection Matrix

System matched air and electric torque pumps that are ideal for use with hydraulic wrenches.

Page: 273

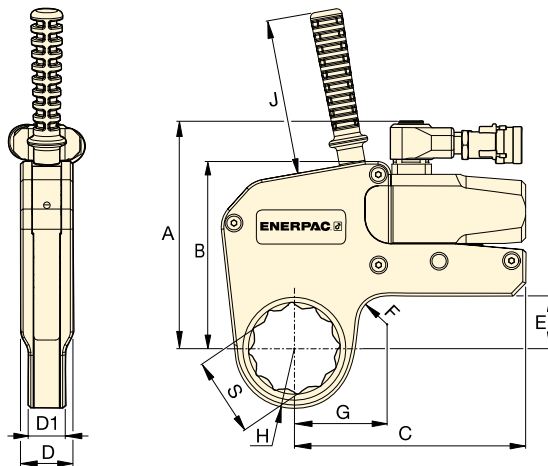

Torque Wrench Hoses

Use Enerpac THQ-700 Series hoses with W-Series torque wrenches to ensure the integrity of your hydraulic system.

2 meters long, 2 hoses	THQ702T
6 meters long, 2 hoses	THQ706T
12 meters long, 2 hoses	THQ712T

SELECTION CHART

Hexagonal Size		Nominal Torque @ 690 bar (Nm)	UltraSlim Cassette * Model Nr.	Minimum Torque @ 69 bar (Nm)	Nose Radius H (mm)	Dimensions (mm)									Drive Unit Model Nr. ** (sold separately)	
S (mm)	S (inch)					G	A	B	C	D	D1	E	F	J		(kg)
46	1 ¹³ / ₁₆	2685	W2113SL	269	36,5	59,6	140,7	109,3	147,7	32,4	25,4	24,0	20,0	120	2,2	W2000PX
50	2	2685	W2200SL	269	38,8	61,1									2,2	
55	2 ³ / ₁₆	2685	W2203SL	269	41,5	63,2									2,2	
60	2 ³ / ₈	2685	W2206SL	269	44,5	65,1									2,2	
46	1 ¹³ / ₁₆	5911	W4113SL	591	39,5	67,2	175,6	144,5	178,5	40,5	28,6	40,8	20,0	120	4,6	W4000PX
55	2 ³ / ₁₆	5911	W4203SL	591	44,0	68,7									4,6	
60	2 ³ / ₈	5911	W4206SL	591	48,0	71,6									4,7	
65	2 ⁹ / ₁₆	5911	W4209SL	591	50,5	74,1									4,7	
70	2 ³ / ₄	5911	W4212SL	591	53,5	75,6									4,7	
75	2 ¹⁵ / ₁₆	5911	W4215SL	591	56,0	76,0	4,7									

* Bi-Hexagonal Cassette includes top mounted straight handle.

** Cassette may also be used with W2000X and W4000X drive units, featuring double-swivel manifolds. Weight of drive units: W2000X = 1,4 kg; W4000X = 2,0 kg.

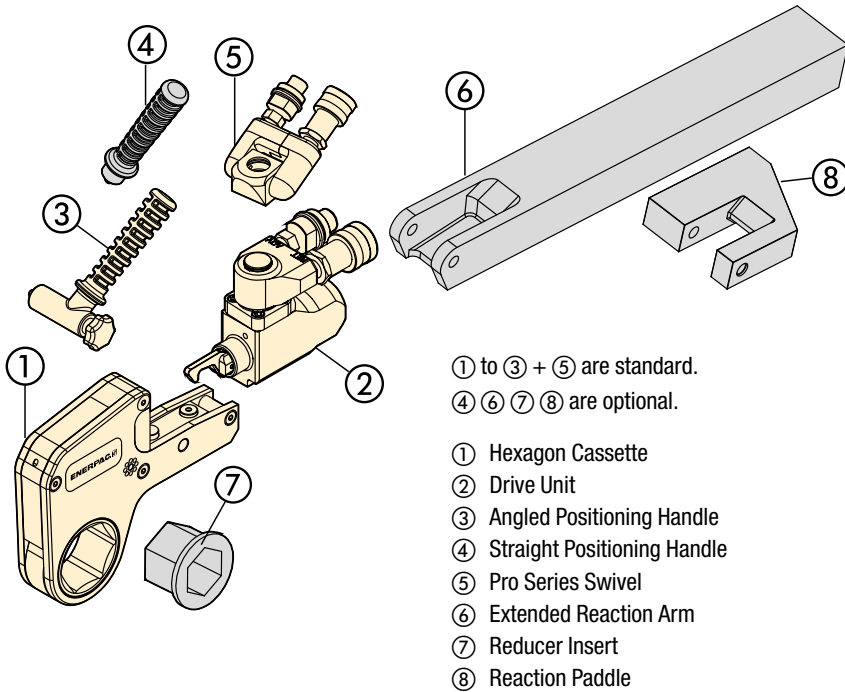

① to ③ + ⑤ are standard.
④ ⑥ ⑦ ⑧ are optional.

- ① Hexagon Cassette
- ② Drive Unit
- ③ Angled Positioning Handle
- ④ Straight Positioning Handle
- ⑤ Pro Series Swivel
- ⑥ Extended Reaction Arm
- ⑦ Reducer Insert
- ⑧ Reaction Paddle

WTE WRP Series



WTE-Series, Extended Reaction Arm

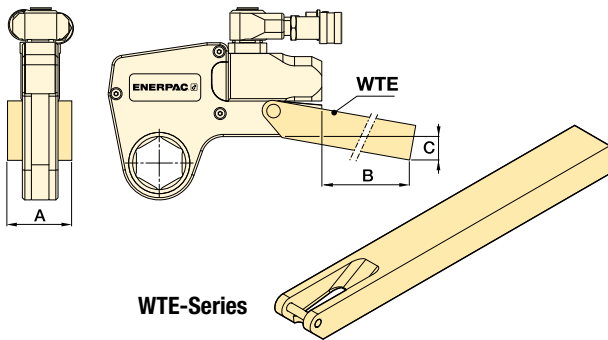

- Full torque rated
- Increases tool fit in restricted access areas.

For Torque Wrench Model Number	Model Number	Dimensions (mm)			(kg) *
		A	B	C	
W2000PX	WTE20	56	398	76	2,6
W4000PX	WTE40	66	436	74	4,6
W8000PX	WTE80	85	449	55	7,6
W15000PX	WTE150	102	498	72	12,0
W22000PX	WTE220	114	524	77	17,3
W35000PX	WTE350	127	419	133	17,8

* Weights indicated are for the accessories only and do not include the wrench.

WRP-Series, Low Profile Reaction Paddles

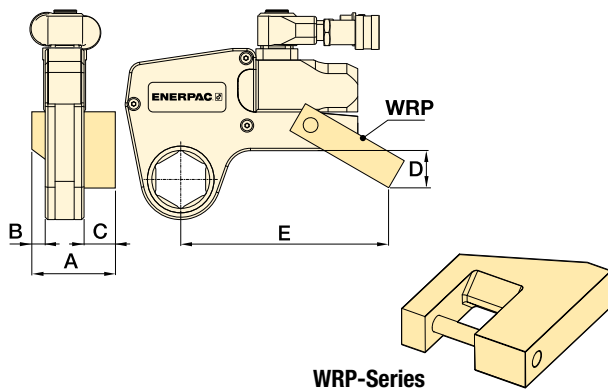

- Lightweight interchangeable design
- Allows for offset reaction when in-line reaction is not available.

For Torque Wrench Model Nr.	Model Number	Dimensions (mm)					(kg) *
		A	B	C	D	E	
W2000PX	WRP20	84	16	35	45	148	0,4
W4000PX	WRP40	109	21	47	59	190	0,8
W8000PX	WRP80	137	26	57	69	223	2,0
W15000PX	WRP150	165	32	69	87	257	3,9
W22000PX	WRP220	207	37	91	134	317	7,2
W35000PX	WRP350	225	42	91	182	367	10,6

* Weights indicated are for the accessories only and do not include the wrench.

Custom Torque Wrenches and Bolt Tensioners

Looking for customized components to help solve your torquing problems? Enerpac has the experience and capabilities to help find solutions to your problems.

Enerpac hydraulic torque wrenches are designed to accommodate most bolting applications. However, due to space constraints, location of reaction points or need for special sockets and adapters, there is often a need for customized components.



◀ Custom S6000X hydraulic torque wrench fitted with a custom reaction arm/socket.



◀ Enerpac Multi Stud Tensioning (MST) system capable of tensioning every single stud in a joint simultaneously.



◀ Custom hydraulic tensioners to suit 5 inch studs load output 4200 kN.

Overview Custom Torque Wrenches and Bolt Tensioners



▲ Custom S11000X torque wrench with a custom torque link and reaction roller.

Customizable features on torque wrenches:

- Reaction Arms
- Torque Links (split or layered for extremely space restricted applications)
- Reaction Roller Assemblies
- Sockets (direct drive, castellated, peg-drive, stacked)
- Drives (direct Allen, spline, square drive size)
- Hexagon Reducing and Square Drive Inserts.

Customizable features on bolt tensioners:

- Adaptor kits with puller sleeves to suit different thread and/or pitch sizes
- Nut rotating sockets to accommodate different nut A/F (across flats) sizes
- Bridges to suit round or non-standard nuts or clear obstructions
- Sockets (direct drive, castellated, peg-drive, stacked)
- Load cells with various capacities
- Screw-on tensioners to overcome space restrictions.

▼ RSL-Drive Units with interchangeable RLP-Hexagon Cassette and RSQ-Square Drive Cassette



Safety and Performance

- Innovative design that completely encloses all moving parts and minimizes pinch points
- 30-35° rotation angle provides added productivity while avoiding “tool lock on” which is common with some torque wrench designs.

Simplicity

- Simple robust alloy steel design with just three moving parts for reduced maintenance
- Robust handles are available for both sides and the tops of cassettes to allow for extra maneuverability
- Designed to give optimum strength to weight and torque to weight ratios
- Minimum nose radius for trouble-free tool fit.

Versatility

- Interchangeable cassette design
- Wide range of hexagon sizes available for all applications
- Reaction arm has a simple dial lock for rapid change
- For use in multiple industrial, energy, and oil and gas applications.

Accuracy

- Constant torque output provides accuracy of $\pm 3\%$ across full stroke.

Setting New Standards in Safety, Simplicity and Performance



RLP-Low Profile Hexagon Cassettes

For the metric and imperial sizes of hexagon cassettes see pages 244 - 251.



RSQ-Square Drive Cassettes

RSQ-Square Drive Cassettes are interchangeable with the RLP-Hexagon Cassettes. They all use the same RSL-drive unit.

Page: 252



Back-Up Spanners

To be used to stop the back nut from turning during make up or break out. Two hexagon sizes in one tool.

Page: 225



Torque Pumps

Visit enerpac.com for system matched air and electric torque pumps that are ideal for use with hydraulic torque wrenches.

Page: 273



Torque Wrench Hoses

Use Enerpac THQ-Series torque wrench hoses with RSL-Series torque wrenches to ensure the integrity of your hydraulic system.

2 meters long, 2 hoses	THQ702T
6 meters long, 2 hoses	THQ706T
12 meters long, 2 hoses	THQ712T

Drive Units for Hexagon & Square Drive Cassettes



One Drive, Two Tools

One RSL-Hydraulic Drive Unit fits RLP-Hexagon Cassette or RSQ-Square Drive Cassette.

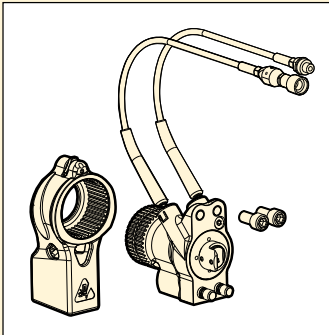

RSL

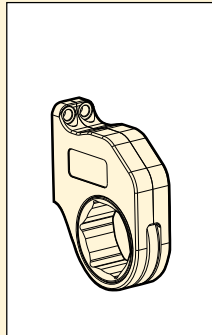

RLP... / RLP...SL

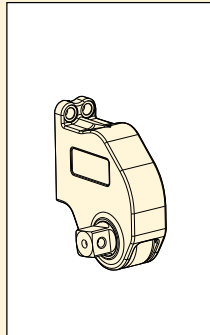

RSQ

RSL Series



Maximum Torque at 690 bar:

1909 - 37.965 Nm

Hexagon Range:

7/8 - 6 1/8 inch

Hexagon Range:

26 - 155 mm

Maximum Operating Pressure:

690 bar

▼ TORQUE WRENCH OPTIONS AND ACCESSORIES

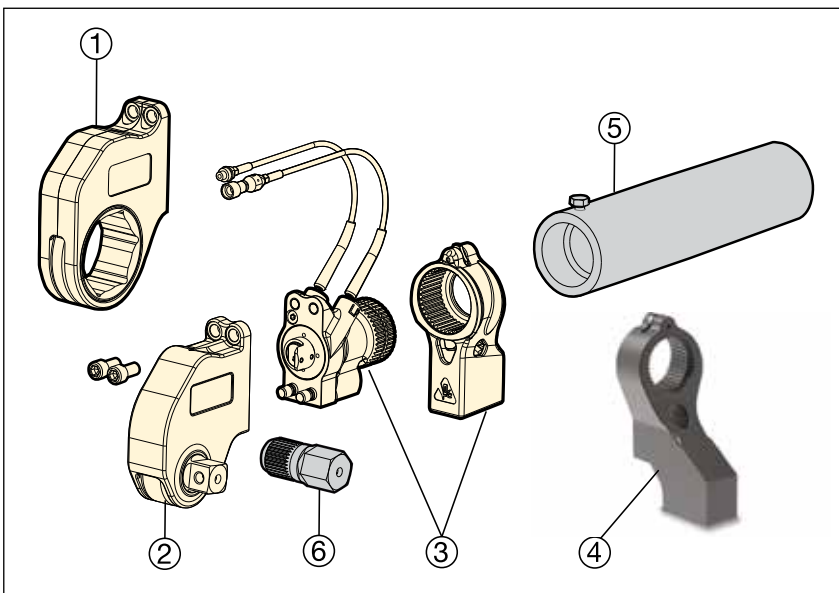

- ① RLP-Hexagon Cassette (pages 244-248)
RLP-SL-Slimline Hexagon Cassette (pages 250-251)
- ② RSQ-Square Drive Cassette (pages 252-253)
- ③ RSL-Drive Unit and Reaction Arm (page 243)

Optional Parts (page 241)

- ④ ERA-Extended Reaction Arm, for RSQ only
- ⑤ ERT-Extended Reaction Tube, for RLP only

Optional Parts (only available per request)

- ⑥ Hexagon Bit

▼ SELECTION CHART

Hexagon Cassette Range (A/F) (see pages 244 - 251 for sizes and model numbers)		Maximum Torque Output at 690 bar		Drive Unit Model Number	Minimum Torque Output at 69 bar		(kg)
(inch)	(mm)	(Ft.lbs)	(Nm)		(Ft.lbs)	(Nm)	
7/8 - 2 3/8	26 - 60	1408	1909	RSL1500	141	191	1,6
1 5/16 - 2 15/16	33 - 75	3080	4176	RSL3000	308	417	2,6
1 11/16 - 3 1/8	46 - 80	5303	7190	RSL5000	530	719	4,1
2 3/8 - 3 1/8	60 - 80	7862	10.659	RSL8000	786	1066	4,9
2 7/16 - 4 5/8	62 - 110	11.154	15.123	RSL11000	1115	1512	5,3
2 15/16 - 4 5/8	75 - 115	18.843	25.547	RSL19000	1884	2554	9,1
3 1/8 - 6 1/8	80 - 155	28.002	37.965	RSL28000	2800	3796	10,0



Select the Right Torque: Use Enerpac Bolting Integrity Software Solutions

Comprehensive on-line software solutions for Bolted Joint Integrity.

The software offers Tool selection, Bolt Load calculations and Tool pressure settings, as well as, a combined Application Data Sheet and Joint Completion Report. Custom Joint information can also be entered.

Hexagon Cassettes for RSL-Series

ENERPAC 

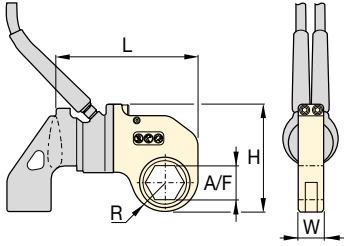

Hexagon Range:
7/8 - 6 1/8 inch



Hexagon Range:
26 - 155 mm

Maximum Operating Pressure:
690 bar

RSL Series



▼ **SELECTION CHART**

Drive Unit Model Number	Hexagon Size A/F		Hexagon Cassette Model Number	Maximum Torque		Dimensions (inch)					Dimensions (mm)				
	(inch)	(mm)		(Ft.lbs)	(Nm)	R	L	W	H		(lbs)	R	L	W	
RSL1500	7/8	-	RLP1014	320	434	0.79	6.00	1.25	4.33	2.2	20,1	152,4	31,8	110,0	1,0
	1 1/16	26	RLP1101	640	868	0.95	6.05	1.25	4.50	2.2	24,1	153,7	31,8	114,3	1,0
	1 1/8	-	RLP1102	640	868	1.03	6.12	1.25	4.57	2.3	26,2	155,4	31,8	116,1	1,0
	1 3/16	30	RLP1103	640	868	1.03	6.12	1.25	4.57	2.3	26,2	155,4	31,8	116,1	1,0
	1 1/4	32	RLP1104	640	868	1.03	6.12	1.25	4.57	2.3	26,2	155,4	31,8	116,1	1,0
	1 5/16	33	RLP1105	900	1220	1.15	6.24	1.25	4.69	2.4	29,2	158,5	31,8	119,1	1,1
	1 3/8	35	RLP1106	900	1220	1.15	6.24	1.25	4.69	2.4	29,2	158,5	31,8	119,1	1,1
	1 7/16	36	RLP1107	900	1220	1.15	6.24	1.25	4.69	2.4	29,2	158,5	31,8	119,1	1,1
	1 1/2	38	RLP1108	1408	1909	1.31	6.41	1.25	4.86	2.7	33,3	162,8	31,8	123,4	1,2
	1 9/16	-	RLP1109	1408	1909	1.31	6.41	1.25	4.86	2.7	33,3	162,8	31,8	123,4	1,2
	1 5/8	41	RLP1110	1408	1909	1.31	6.41	1.25	4.86	2.7	33,3	162,8	31,8	123,4	1,2
	1 11/16	-	RLP1111	1408	1909	1.40	6.49	1.25	4.94	2.7	35,6	164,8	31,8	125,5	1,2
	1 3/4	-	RLP1112	1408	1909	1.40	6.49	1.25	4.94	2.7	35,6	164,8	31,8	125,5	1,2
	1 13/16	46	RLP1113	1408	1909	1.40	6.49	1.25	4.94	2.7	35,6	164,8	31,8	125,5	1,2
	1 7/8	-	RLP1114	1408	1909	1.48	6.58	1.25	5.03	2.7	37,6	167,1	31,8	127,8	1,2
	1 9/16	-	RLP1115	1408	1909	1.48	6.58	1.25	5.03	2.7	37,6	167,1	31,8	127,8	1,2
	2	50	RLP1200	1408	1909	1.48	6.58	1.25	5.03	2.7	37,6	167,1	31,8	127,8	1,2
	2 1/16	-	RLP1201	1408	1909	1.58	6.68	1.25	5.13	2.7	40,1	169,7	31,8	130,3	1,2
	2 1/8	-	RLP1202	1408	1909	1.58	6.68	1.25	5.13	2.7	40,1	169,7	31,8	130,3	1,2
	2 3/16	55	RLP1203	1408	1909	1.58	6.68	1.25	5.13	2.7	40,1	169,7	31,8	130,3	1,2
2 1/4	-	RLP1204	1408	1909	1.70	6.79	1.25	5.24	2.8	43,2	172,5	31,8	133,1	1,3	
2 5/16	-	RLP1205	1408	1909	1.70	6.79	1.25	5.24	2.8	43,2	172,5	31,8	133,1	1,3	
2 3/8	60	RLP1206	1408	1909	1.70	6.79	1.25	5.24	2.8	43,2	172,5	31,8	133,1	1,3	
RSL3000	1 5/16	33	RLP3105	900	1220	1.18	7.62	1.38	5.49	3.5	30,0	193,5	35,1	139,4	1,6
	1 3/8	35	RLP3106	900	1220	1.18	7.62	1.38	5.49	3.5	30,0	193,5	35,1	139,4	1,6
	1 7/16	36	RLP3107	900	1220	1.18	7.62	1.38	5.49	3.5	30,0	193,5	35,1	139,4	1,6
	1 1/2	38	RLP3108	1200	1627	1.32	7.77	1.38	5.63	3.9	33,5	197,4	35,1	143,0	1,8
	1 9/16	-	RLP3109	1200	1627	1.32	7.77	1.38	5.63	3.9	33,5	197,4	35,1	143,0	1,8
	1 5/8	41	RLP3110	1200	1627	1.32	7.77	1.38	5.63	3.9	33,5	197,4	35,1	143,0	1,8
	1 11/16	-	RLP3111	1900	2576	1.47	7.87	1.38	5.78	4.0	37,3	199,9	35,1	146,8	1,8
	1 3/4	-	RLP3112	1900	2576	1.47	7.87	1.38	5.78	4.0	37,3	199,9	35,1	146,8	1,8
	1 13/16	46	RLP3113	1900	2576	1.47	7.87	1.38	5.78	4.0	37,3	199,9	35,1	146,8	1,8
	1 7/8	-	RLP3114	2600	3526	1.60	8.04	1.38	5.92	4.5	40,6	204,2	35,1	150,4	2,0
	1 15/16	-	RLP3115	2600	3526	1.60	8.04	1.38	5.92	4.5	40,6	204,2	35,1	150,4	2,0
	2	50	RLP3200	2600	3526	1.60	8.04	1.38	5.92	4.5	40,6	204,2	35,1	150,4	2,0
	2 1/16	-	RLP3201	3080	4176	1.76	8.16	1.38	6.08	4.7	44,7	207,3	35,1	154,4	2,1
	2 1/8	-	RLP3202	3080	4176	1.76	8.16	1.38	6.08	4.7	44,7	207,3	35,1	154,4	2,1
	2 3/16	55	RLP3203	3080	4176	1.76	8.16	1.38	6.08	4.7	44,7	207,3	35,1	154,4	2,1
	2 1/4	-	RLP3204	3080	4176	1.84	8.25	1.38	6.15	4.8	46,7	209,6	35,1	156,2	2,2
	2 5/16	-	RLP3205	3080	4176	1.84	8.25	1.38	6.15	4.8	46,7	209,6	35,1	156,2	2,2
	2 3/8	60	RLP3206	3080	4176	1.84	8.25	1.38	6.15	4.8	46,7	209,6	35,1	156,2	2,2
	2 7/16	62	RLP3207	3080	4176	1.95	8.14	1.38	6.26	4.6	49,5	206,8	35,1	159,0	2,1
	2 1/2	63	RLP3208	3080	4176	1.95	8.14	1.38	6.26	4.6	49,5	206,8	35,1	159,0	2,1
2 9/16	65	RLP3209	3080	4176	1.95	8.14	1.38	6.26	4.6	49,5	206,8	35,1	159,0	2,1	
2 5/8	-	RLP3210	3080	4176	2.04	8.23	1.38	6.36	4.4	51,8	209,0	35,1	161,5	2,0	
2 11/16	-	RLP3211	3080	4176	2.04	8.23	1.38	6.36	4.4	51,8	209,0	35,1	161,5	2,0	
2 3/4	70	RLP3212	3080	4176	2.04	8.23	1.38	6.36	4.4	51,8	209,0	35,1	161,5	2,0	
2 13/16	-	RLP3213	3080	4176	2.16	8.34	1.38	6.54	4.7	54,9	211,8	35,1	166,1	2,1	
2 7/8	-	RLP3214	3080	4176	2.16	8.34	1.38	6.54	4.7	54,9	211,8	35,1	166,1	2,1	
2 15/16	75	RLP3215	3080	4176	2.16	8.34	1.38	6.54	4.7	54,9	211,8	35,1	166,1	2,1	

IMPORTANT: RSL-drive units must be ordered separately to operate the RLP-Hexagon Cassettes.

Hexagon Cassettes for RSL-Series

Hexagon Range:
7/8 - 6 1/8 inch

Hexagon Range:
26 - 155 mm

Maximum Operating Pressure:
690 bar

RSL Series

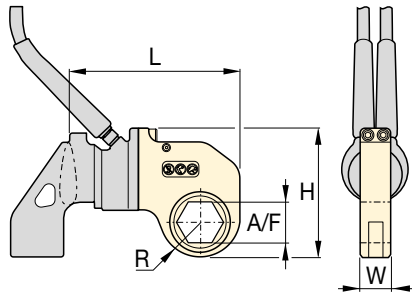

Slimline Stepped-Width Hexagon Cassettes

For accessing narrow spaces **RLP...SL** Stepped-Width Hexagon Cassettes are available. Slimline cassettes use same drive unit as standard RLP-cassettes.

Page: **251**

▼ SELECTION CHART

Drive Unit Model Number	Hexagon Size A/F		Hexagon Cassette Model Number	Maximum Torque		Dimensions (inch)				⚖️ (lbs)	Dimensions (mm)				⚖️ (kg)
	(inch)	(mm)		(Ft.lbs)	(Nm)	R	L	W	H		R	L	W	H	
RSL5000	1 11/16	-	RLP5111	2600	3526	1.61	9.08	1.75	6.52	6.6	40,9	230,6	44,5	165,6	3,0
	1 3/4	-	RLP5112	2600	3526	1.61	9.08	1.75	6.52	6.6	40,9	230,6	44,5	165,6	3,0
	1 13/16	46	RLP5113	2600	3526	1.61	9.08	1.75	6.52	6.6	40,9	230,6	44,5	165,6	3,0
	1 7/8	-	RLP5114	2600	3526	1.61	9.08	1.75	6.52	6.6	40,9	230,6	44,5	165,6	3,0
	1 15/16	-	RLP5115	2600	3526	1.61	9.08	1.75	6.52	6.6	40,9	230,6	44,5	165,6	3,0
	2	50	RLP5200	2600	3526	1.61	9.08	1.75	6.52	6.6	40,9	230,6	44,5	165,6	3,0
	2 1/16	-	RLP5201	3500	4746	1.71	9.18	1.75	6.62	6.5	43,4	233,2	44,5	168,1	2,9
	2 1/8	-	RLP5202	3500	4746	1.71	9.18	1.75	6.62	6.5	43,4	233,2	44,5	168,1	2,9
	2 3/16	55	RLP5203	3500	4746	1.71	9.18	1.75	6.62	6.5	43,4	233,2	44,5	168,1	2,9
	2 1/4	-	RLP5204	4500	6102	1.87	9.34	1.75	6.78	7.0	47,5	237,2	44,5	172,2	3,2
	2 5/16	-	RLP5205	4500	6102	1.87	9.34	1.75	6.78	7.0	47,5	237,2	44,5	172,2	3,2
	2 3/8	60	RLP5206	4500	6102	1.87	9.34	1.75	6.78	7.0	47,5	237,2	44,5	172,2	3,2
	2 7/16	62	RLP5207	5303	7191	2.01	9.48	1.75	6.92	7.0	51,1	240,8	44,5	175,8	3,2
	2 1/2	63	RLP5208	5303	7191	2.01	9.48	1.75	6.92	7.0	51,1	240,8	44,5	175,8	3,2
	2 9/16	65	RLP5209	5303	7191	2.01	9.48	1.75	6.92	7.0	51,1	240,8	44,5	175,8	3,2
	2 5/8	-	RLP5210	5303	7191	2.16	9.63	1.75	7.07	7.5	54,9	244,6	44,5	179,6	3,4
	2 11/16	-	RLP5211	5303	7191	2.16	9.63	1.75	7.07	7.5	54,9	244,6	44,5	179,6	3,4
	2 3/4	70	RLP5212	5303	7191	2.16	9.63	1.75	7.07	7.5	54,9	244,6	44,5	179,6	3,4
	2 13/16	-	RLP5213	5303	7191	2.24	9.71	1.75	7.15	7.5	56,9	246,6	44,5	181,6	3,4
	2 7/8	-	RLP5214	5303	7191	2.24	9.71	1.75	7.15	7.5	56,9	246,6	44,5	181,6	3,4
2 15/16	75	RLP5215	5303	7191	2.24	9.71	1.75	7.15	7.5	56,9	246,6	44,5	181,6	3,4	
3	-	RLP5300	5303	7191	2.26	9.73	1.75	7.17	7.2	57,4	247,1	44,5	182,1	3,3	
3 1/16	-	RLP5301	5303	7191	2.26	9.73	1.75	7.17	7.2	57,4	247,1	44,5	182,1	3,3	
3 1/8	80	RLP5302	5303	7191	2.26	9.73	1.75	7.17	7.2	57,4	247,1	44,5	182,1	3,3	
RSL8000	2 3/8	60	RLP8206	4500	6102	1.87	9.53	2.25	7.00	8.9	47,5	242,1	57,2	177,8	4,0
	2 7/16	62	RLP8207	5800	7865	2.01	9.67	2.25	7.13	9.0	51,1	245,6	57,2	181,1	4,1
	2 1/2	63	RLP8208	5800	7865	2.01	9.67	2.25	7.13	9.0	51,1	245,6	57,2	181,1	4,1
	2 9/16	65	RLP8209	5800	7865	2.01	9.67	2.25	7.13	9.0	51,1	245,6	57,2	181,1	4,1
	2 5/8	-	RLP8210	7862	10.661	2.16	9.82	2.25	7.28	9.6	54,9	249,4	57,2	184,9	4,4
	2 11/16	-	RLP8211	7862	10.661	2.16	9.82	2.25	7.28	9.6	54,9	249,4	57,2	184,9	4,4
	2 3/4	70	RLP8212	7862	10.661	2.16	9.82	2.25	7.28	9.6	54,9	249,4	57,2	184,9	4,4
	2 13/16	-	RLP8213	7862	10.661	2.24	9.90	2.25	7.38	9.6	56,9	251,5	57,2	187,5	4,4
	2 7/8	-	RLP8214	7862	10.661	2.24	9.90	2.25	7.38	9.6	56,9	251,5	57,2	187,5	4,4
	2 15/16	75	RLP8215	7862	10.661	2.24	9.90	2.25	7.38	9.6	56,9	251,5	57,2	187,5	4,4
	3	-	RLP8300	7862	10.661	2.26	9.92	2.25	7.39	9.3	57,4	252,0	57,2	187,7	4,2
	3 1/16	-	RLP8301	7862	10.661	2.26	9.92	2.25	7.39	9.3	57,4	252,0	57,2	187,7	4,2
	3 1/8	80	RLP8302	7862	10.661	2.26	9.92	2.25	7.39	9.3	57,4	252,0	57,2	187,7	4,2

IMPORTANT: RSL-drive units must be ordered separately to operate the RLP-Hexagon Cassettes.

Hexagon Cassettes for RSL-Series

ENERPAC 

Hexagon Range:
7/8 - 6 1/8 inch



Hexagon Range:
26 - 155 mm

Maximum Operating Pressure:
690 bar

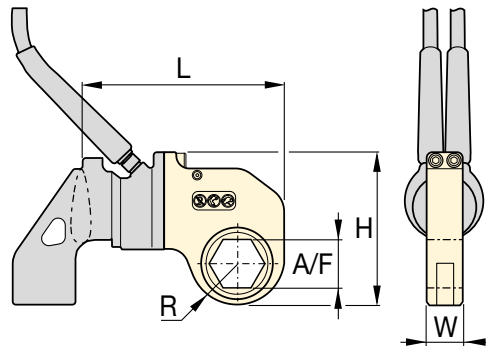
RSL Series



▼ **SELECTION CHART**

Drive Unit Model Number	Hexagon Size A/F		Hexagon Cassette Model Number	Maximum Torque		Dimensions (inch)					Dimensions (mm)				
	(inch)	(mm)		(Ft.lbs)	(Nm)	R	L	W	H	(lbs)	R	L	W	H	(kg)
RSL11000	2 7/16	62	RLP11207	5800	7865	1.98	10.00	2.50	8.03	14.2	50,3	254,0	63,5	204,0	6,4
	2 1/2	-	RLP11208	5800	7865	1.98	10.00	2.50	8.03	14.2	50,3	254,0	63,5	204,0	6,4
	2 9/16	65	RLP11209	5800	7865	1.98	10.00	2.50	8.03	14.2	50,3	254,0	63,5	204,0	6,4
	2 5/8	-	RLP11210	7300	9899	2.19	11.20	2.50	8.23	14.8	55,6	284,5	63,5	209,0	6,7
	2 11/16	-	RLP11211	7300	9899	2.19	11.20	2.50	8.23	14.8	55,6	284,5	63,5	209,0	6,7
	2 3/4	70	RLP11212	7300	9899	2.19	11.20	2.50	8.23	14.8	55,6	284,5	63,5	209,0	6,7
	2 13/16	-	RLP11213	9000	12.204	2.29	11.31	2.50	8.34	14.8	58,2	287,3	63,5	211,8	6,7
	2 7/8	-	RLP11214	9000	12.204	2.29	11.31	2.50	8.34	14.8	58,2	287,3	63,5	211,8	6,7
	2 15/16	75	RLP11215	9000	12.204	2.29	11.31	2.50	8.34	14.8	58,2	287,3	63,5	211,8	6,7
	3	-	RLP11300	11.154	15.125	2.43	11.44	2.50	8.47	15.2	61,7	290,6	63,5	215,1	6,9
	3 1/16	-	RLP11301	11.154	15.125	2.43	11.44	2.50	8.47	15.2	61,7	290,6	63,5	215,1	6,9
	3 1/8	80	RLP11302	11.154	15.125	2.43	11.44	2.50	8.47	15.2	61,7	290,6	63,5	215,1	6,9
	3 3/16	-	RLP11303	11.154	15.125	2.60	11.71	2.50	8.64	16.6	66,0	297,4	63,5	219,5	7,5
	-	85	RLP11085M	11.154	15.125	2.60	11.71	2.50	8.64	16.6	66,0	297,4	63,5	219,5	7,5
	3 1/4	-	RLP11304	11.154	15.125	2.60	11.71	2.50	8.64	16.6	66,0	297,4	63,5	219,5	7,5
	3 5/16	-	RLP11305	11.154	15.125	2.60	11.71	2.50	8.64	16.6	66,0	297,4	63,5	219,5	7,5
	3 3/8	-	RLP11306	11.154	15.125	2.60	11.71	2.50	8.64	16.6	66,0	297,4	63,5	219,5	7,5
	3 7/16	-	RLP11307	11.154	15.125	2.60	11.71	2.50	8.64	16.6	66,0	297,4	63,5	219,5	7,5
	3 1/2	-	RLP11308	11.154	15.125	2.60	11.71	2.50	8.64	16.6	66,0	297,4	63,5	219,5	7,5
	-	90	RLP11090M	11.154	15.125	2.88	11.89	2.50	8.92	17.2	73,2	302,0	63,5	226,6	7,8
	3 9/16	-	RLP11309	11.154	15.125	2.88	11.89	2.50	8.92	17.2	73,2	302,0	63,5	226,6	7,8
	3 5/8	-	RLP11310	11.154	15.125	2.88	11.89	2.50	8.92	17.2	73,2	302,0	63,5	226,6	7,8
	3 11/16	-	RLP11311	11.154	15.125	2.88	11.89	2.50	8.92	17.2	73,2	302,0	63,5	226,6	7,8
	3 3/4	95	RLP11312	11.154	15.125	2.88	11.89	2.50	8.92	17.2	73,2	302,0	63,5	226,6	7,8
	3 13/16	-	RLP11313	11.154	15.125	2.88	11.89	2.50	8.92	17.2	73,2	302,0	63,5	226,6	7,8
	3 7/8	-	RLP11314	11.154	15.125	2.88	11.89	2.50	8.92	17.2	73,2	302,0	63,5	226,6	7,8
	3 15/16	100	RLP11315	11.154	15.125	2.98	12.00	2.50	9.03	16.4	75,7	304,8	63,5	229,4	7,4
	4	-	RLP11400	11.154	15.125	2.98	12.00	2.50	9.03	16.4	75,7	304,8	63,5	229,4	7,4
	4 1/16	-	RLP11401	11.154	15.125	2.98	12.00	2.50	9.03	16.4	75,7	304,8	63,5	229,4	7,4
	4 1/8	105	RLP11402	11.154	15.125	2.98	12.00	2.50	9.03	16.4	75,7	304,8	63,5	229,4	7,4
	4 1/4	-	RLP11404	11.154	15.125	2.98	12.00	2.50	9.03	16.4	75,7	304,8	63,5	229,4	7,4
	4 5/16	110	RLP11405	11.154	15.125	3.25	12.27	2.50	9.30	17.6	82,6	311,7	63,5	236,2	8,0
4 1/2	-	RLP11408	11.154	15.125	3.25	12.27	2.50	9.30	17.6	82,6	311,7	63,5	236,2	8,0	
-	115	RLP11115M	11.154	15.125	3.25	12.27	2.50	9.30	17.6	82,6	311,7	63,5	236,2	8,0	
4 5/8	-	RLP11410	11.154	15.125	3.25	12.27	2.50	9.30	17.6	82,6	311,7	63,5	236,2	8,0	

IMPORTANT: RSL-drive units must be ordered separately to operate the RLP-Hexagon Cassettes.

Hexagon Cassettes for RSL-Series

Hexagon Range:
7/8 - 6 1/8 inch

Hexagon Range:
26 - 155 mm

Maximum Operating Pressure:
690 bar

**RSL
Series**

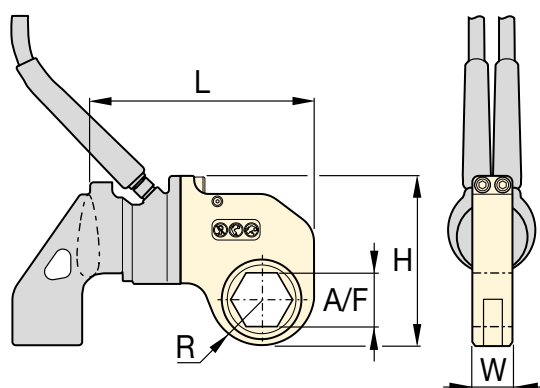

▼ SELECTION CHART

Drive Unit Model Number	Hexagon Size A/F		Hexagon Cassette Model Number	Maximum Torque		Dimensions (inch)				⚖️ (lbs)	Dimensions (mm)				⚖️ (kg)
	(inch)	(mm)		(Ft.lbs)	(Nm)	R	L	W	H		R	L	W	H	
RSL19000	2 ¹⁵ / ₁₆	75	RLP19215	11.000	14.916	2.45	12.72	2.75	9.44	21.5	62,2	323,1	69,9	239,8	9,8
	3	-	RLP19300	11.000	14.916	2.45	12.72	2.75	9.44	21.5	62,2	323,1	69,9	239,8	9,8
	3 ¹ / ₁₆	-	RLP19301	11.000	14.916	2.45	12.72	2.75	9.44	21.5	62,2	323,1	69,9	239,8	9,8
	3 ¹ / ₈	80	RLP19302	11.000	14.916	2.45	12.72	2.75	9.44	21.5	62,2	323,1	69,9	239,8	9,8
	3 ³ / ₁₆	-	RLP19303	16.000	21.696	2.77	13.04	2.75	9.76	22.6	70,4	331,2	69,9	247,9	10,3
	-	85	RLP19085M	16.000	21.696	2.77	13.04	2.75	9.76	22.6	70,4	331,2	69,9	247,9	10,3
	3 ¹ / ₄	-	RLP19304	16.000	21.696	2.77	13.04	2.75	9.76	22.6	70,4	331,2	69,9	247,9	10,3
	3 ⁵ / ₁₆	-	RLP19305	16.000	21.696	2.77	13.04	2.75	9.76	22.6	70,4	331,2	69,9	247,9	10,3
	3 ³ / ₈	-	RLP19306	16.000	21.696	2.77	13.04	2.75	9.76	22.6	70,4	331,2	69,9	247,9	10,3
	3 ⁷ / ₁₆	-	RLP19307	16.000	21.696	2.77	13.04	2.75	9.76	22.6	70,4	331,2	69,9	247,9	10,3
	3 ¹ / ₂	-	RLP19308	16.000	21.696	2.77	13.04	2.75	9.76	22.6	70,4	331,2	69,9	247,9	10,3
	-	90	RLP19090M	18.843	25.551	2.95	13.22	2.75	9.94	23.8	74,9	335,8	69,9	252,5	10,8
	3 ⁹ / ₁₆	-	RLP19309	18.843	25.551	2.95	13.22	2.75	9.94	23.8	74,9	335,8	69,9	252,5	10,8
	3 ⁵ / ₈	-	RLP19310	18.843	25.551	2.95	13.22	2.75	9.94	23.8	74,9	335,8	69,9	252,5	10,8
	3 ¹¹ / ₁₆	-	RLP19311	18.843	25.551	2.95	13.22	2.75	9.94	23.8	74,9	335,8	69,9	252,5	10,8
	3 ³ / ₄	95	RLP19312	18.843	25.551	2.95	13.22	2.75	9.94	23.8	74,9	335,8	69,9	252,5	10,8
	3 ¹³ / ₁₆	-	RLP19313	18.843	25.551	2.95	13.22	2.75	9.94	23.8	74,9	335,8	69,9	252,5	10,8
	3 ⁷ / ₈	-	RLP19314	18.843	25.551	2.95	13.22	2.75	9.94	23.8	74,9	335,8	69,9	252,5	10,8
	3 ¹⁵ / ₁₆	100	RLP19315	18.843	25.551	3.30	13.57	2.75	10.28	25.3	83,8	344,7	69,9	261,1	11,5
	4	-	RLP19400	18.843	25.551	3.30	13.57	2.75	10.28	25.3	83,8	344,7	69,9	261,1	11,5
	4 ¹ / ₁₆	-	RLP19401	18.843	25.551	3.30	13.57	2.75	10.28	25.3	83,8	344,7	69,9	261,1	11,5
	4 ¹ / ₈	105	RLP19402	18.843	25.551	3.30	13.57	2.75	10.28	25.3	83,8	344,7	69,9	261,1	11,5
	4 ³ / ₁₆	-	RLP19403	18.843	25.551	3.30	13.57	2.75	10.28	25.3	83,8	344,7	69,9	261,1	11,5
	4 ¹ / ₄	-	RLP19404	18.843	25.551	3.30	13.57	2.75	10.28	25.3	83,8	344,7	69,9	261,1	11,5
	4 ⁵ / ₁₆	110	RLP19405	18.843	25.551	3.44	13.71	2.75	10.43	25.6	87,4	348,2	69,9	264,9	11,6
	4 ³ / ₈	-	RLP19406	18.843	25.551	3.44	13.71	2.75	10.43	25.6	87,4	348,2	69,9	264,9	11,6
	4 ⁷ / ₁₆	-	RLP19407	18.843	25.551	3.44	13.71	2.75	10.43	25.6	87,4	348,2	69,9	264,9	11,6
	4 ¹ / ₂	-	RLP19408	18.843	25.551	3.44	13.71	2.75	10.43	25.6	87,4	348,2	69,9	264,9	11,6
-	115	RLP19115M	18.843	25.551	3.44	13.71	2.75	10.43	25.6	87,4	348,2	69,9	264,9	11,6	
4 ⁹ / ₁₆	-	RLP19409	18.843	25.551	3.44	13.71	2.75	10.43	25.6	87,4	348,2	69,9	264,9	11,6	
4 ⁵ / ₈	-	RLP19410	18.843	25.551	3.44	13.71	2.75	10.43	25.6	87,4	348,2	69,9	264,9	11,6	

IMPORTANT: RSL-drive units must be ordered separately to operate the RLP-Hexagon Cassettes.

Hexagon Cassettes for RSL-Series

ENERPAC 

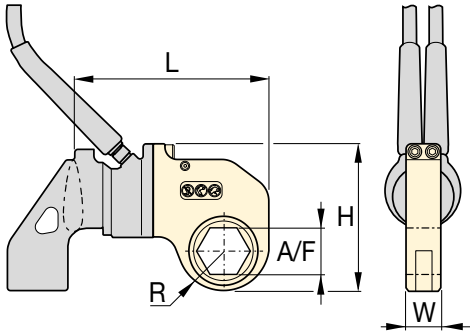

Hexagon Range:
7/8 - 6 1/8 inch



Hexagon Range:
26 - 155 mm

Maximum Operating Pressure:
690 bar

RSL Series



▼ SELECTION CHART

Drive Unit Model Number	Hexagon Size A/F		Hexagon Cassette Model Number	Maximum Torque		Dimensions (inch)					Dimensions (mm)				
	(inch)	(mm)		(Ft.lbs)	(Nm)	R	L	W	H	(lbs)	R	L	W	H	(kg)
RSL28000	3 1/8	80	RLP28302	16.000	21.696	2.56	14.36	3.00	10.54	27.6	65,0	364,7	76,2	267,7	12,5
	3 3/16	-	RLP28303	16.000	21.696	2.56	14.36	3.00	10.54	27.6	65,0	364,7	76,2	267,7	12,5
	-	85	RLP28085M	16.000	21.696	2.56	14.36	3.00	10.54	27.6	65,0	364,7	76,2	267,7	12,5
	3 1/4	-	RLP28304	16.000	21.696	2.56	14.36	3.00	10.54	27.6	65,0	364,7	76,2	267,7	12,5
	3 5/16	-	RLP28305	16.000	21.696	2.56	14.36	3.00	10.54	27.6	65,0	364,7	76,2	267,7	12,5
	3 3/8	-	RLP28306	16.000	21.696	2.56	14.36	3.00	10.54	27.6	65,0	364,7	76,2	267,7	12,5
	3 7/16	-	RLP28307	16.000	21.696	2.56	14.36	3.00	10.54	27.6	65,0	364,7	76,2	267,7	12,5
	3 1/2	-	RLP28308	16.000	21.696	2.56	14.36	3.00	10.54	27.6	65,0	364,7	76,2	267,7	12,5
	-	90	RLP28090M	22.000	29.832	2.92	14.36	3.00	10.77	28.8	74,2	364,7	76,2	273,6	13,1
	3 9/16	-	RLP28309	22.000	29.832	2.92	14.36	3.00	10.77	28.8	74,2	364,7	76,2	273,6	13,1
	3 5/8	-	RLP28310	22.000	29.832	2.92	14.36	3.00	10.77	28.8	74,2	364,7	76,2	273,6	13,1
	3 11/16	-	RLP28311	22.000	29.832	2.92	14.36	3.00	10.77	28.8	74,2	364,7	76,2	273,6	13,1
	3 3/4	95	RLP28312	22.000	29.832	2.92	14.36	3.00	10.77	28.8	74,2	364,7	76,2	273,6	13,1
	3 13/16	-	RLP28313	22.000	29.832	2.92	14.36	3.00	10.77	28.8	74,2	364,7	76,2	273,6	13,1
	3 7/8	-	RLP28314	22.000	29.832	2.92	14.36	3.00	10.77	28.8	74,2	364,7	76,2	273,6	13,1
	3 15/16	100	RLP28315	28.002	37.971	3.29	14.47	3.00	11.14	31.7	83,6	367,5	76,2	283,0	14,4
	4	-	RLP28400	28.002	37.971	3.29	14.47	3.00	11.14	31.7	83,6	367,5	76,2	283,0	14,4
	4 1/16	-	RLP28401	28.002	37.971	3.29	14.47	3.00	11.14	31.7	83,6	367,5	76,2	283,0	14,4
	4 1/8	105	RLP28402	28.002	37.971	3.29	14.47	3.00	11.14	31.7	83,6	367,5	76,2	283,0	14,4
	4 3/16	-	RLP28403	28.002	37.971	3.29	14.47	3.00	11.14	31.7	83,6	367,5	76,2	283,0	14,4
	4 1/4	-	RLP28404	28.002	37.971	3.29	14.47	3.00	11.14	31.7	83,6	367,5	76,2	283,0	14,4
	4 5/16	110	RLP28405	28.002	37.971	3.43	14.61	3.00	11.28	31.5	87,1	371,1	76,2	286,5	14,3
	4 3/8	-	RLP28406	28.002	37.971	3.43	14.61	3.00	11.28	31.5	87,1	371,1	76,2	286,5	14,3
	4 7/16	-	RLP28407	28.002	37.971	3.43	14.61	3.00	11.28	31.5	87,1	371,1	76,2	286,5	14,3
	4 1/2	-	RLP28408	28.002	37.971	3.43	14.61	3.00	11.28	31.5	87,1	371,1	76,2	286,5	14,3
	-	115	RLP28115M	28.002	37.971	3.43	14.61	3.00	11.28	31.5	87,1	371,1	76,2	286,5	14,3
	4 9/16	-	RLP28409	28.002	37.971	3.43	14.61	3.00	11.28	31.5	87,1	371,1	76,2	286,5	14,3
	4 5/8	-	RLP28410	28.002	37.971	3.43	14.61	3.00	11.28	31.5	87,1	371,1	76,2	286,5	14,3
	4 3/4	120	RLP28412	28.002	37.971	3.65	14.83	3.00	11.50	33.5	92,7	376,7	76,2	292,1	15,2
	-	123	RLP28123M	28.002	37.971	3.65	14.83	3.00	11.50	33.5	92,7	376,7	76,2	292,1	15,2
	4 7/8	-	RLP28414	28.002	37.971	3.65	14.83	3.00	11.50	33.5	92,7	376,7	76,2	292,1	15,2
	5	-	RLP28500	28.002	37.971	3.65	14.83	3.00	11.50	33.5	92,7	376,7	76,2	292,1	15,2
	5 1/8	130	RLP28502	28.002	37.971	3.79	14.97	3.00	11.64	33.2	96,3	380,2	76,2	295,7	15,1
	5 3/16	-	RLP28503	28.002	37.971	3.79	14.97	3.00	11.64	33.2	96,3	380,2	76,2	295,7	15,1
	5 1/4	-	RLP28504	28.002	37.971	3.79	14.97	3.00	11.64	33.2	96,3	380,2	76,2	295,7	15,1
	5 3/8	135	RLP28506	28.002	37.971	3.79	14.97	3.00	11.64	33.2	96,3	380,2	76,2	295,7	15,1
	5 1/2	140	RLP28508	28.002	37.971	4.05	15.23	3.00	11.90	33.5	102,9	386,8	76,2	302,3	15,2
	5 9/16	-	RLP28509	28.002	37.971	4.05	15.23	3.00	11.90	33.5	102,9	386,8	76,2	302,3	15,2
	5 5/8	-	RLP28510	28.002	37.971	4.05	15.23	3.00	11.90	33.5	102,9	386,8	76,2	302,3	15,2
	5 3/4	145	RLP28512	28.002	37.971	4.05	15.23	3.00	11.90	33.5	102,9	386,8	76,2	302,3	15,2
5 7/8	150	RLP28514	28.002	37.971	4.22	15.48	3.00	12.15	34.5	107,2	393,2	76,2	308,6	15,6	
-	151	RLP28151M	28.002	37.971	4.22	15.48	3.00	12.15	34.5	107,2	393,2	76,2	308,6	15,6	
6	-	RLP28600	28.002	37.971	4.22	15.48	3.00	12.15	34.5	107,2	393,2	76,2	308,6	15,6	
6 1/8	155	RLP28602	28.002	37.971	4.22	15.48	3.00	12.15	34.5	107,2	393,2	76,2	308,6	15,6	

IMPORTANT: RSL-drive units must be ordered separately to operate the RLP-Hexagon Cassettes.

Accessories for RSL-Series Torque Wrenches

TWMP503, Torque Wrench Moly Paste

- Enerpac 503 Moly Paste reduces friction on threaded fasteners – bolts, nuts and studs
- The low and uniform friction coefficient of 0.06 (torque coefficient, K, of 0.10) creates reliable assembly conditions
- This lubricant stays in place through heat, load and vibration to insure trouble-free disassembly from -29 °C to 400 °C (-20 °F to 750 °F)
- Can of 1,8 kg (4 lb).

▼ TWMP503



for
RSL
Series



ERA-Series, Extended Reaction Arms

For Torque Wrench Model Nr.	Model Number	Dimensions (mm)					🏋️ (kg)
		A	B	C	D	E	
RSL1500 + RSQ	ERA15114	87	145	195	29	36	0,9
	ERA15228	113	181	230	29	36	1,8
	ERA15342	139	226	276	29	36	2,7
	ERA15456	164	236	286	29	36	3,6
	ERA15570	189	287	337	29	36	4,5
RSL3000 + RSQ	ERA30114	105	195	257	34	41	2,7
	ERA30228	131	231	293	34	41	3,6
	ERA30342	156	266	328	34	41	4,5
	ERA30456	181	302	364	34	41	5,4
RSL5000 + RSQ	ERA50114	131	208	284	44	48	4,1
	ERA50228	156	243	320	44	48	5,0
	ERA50342	181	279	355	44	48	5,9
	ERA50456	207	314	391	44	48	6,8
RSL11000 + RSQ	ERA110114	125	219	296	51	59	6,3
	ERA110228	150	255	331	51	59	7,3
	ERA110342	176	291	367	51	59	8,2
	ERA110456	201	326	402	51	59	9,1
RSL28000 + RSQ	ERA280228	171	335	411	57	85	11,3
	ERA280342	197	370	447	57	85	13,6

- Only to be used on RSL-drive units with RSQ-square drive wrenches
- Used in place of standard reaction arm
- Lightweight interchangeable design
- Full torque rated.

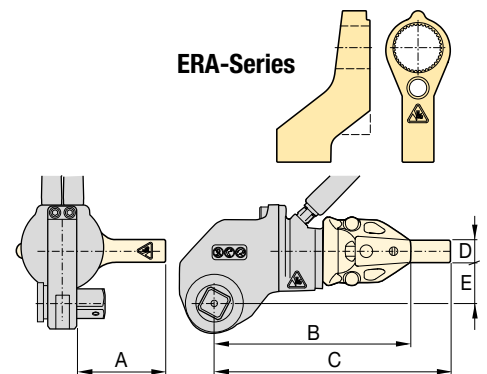

NOTE: Extended Reaction Arms for RSL8000 and RSL19000 are available on request.

ERT-Series, Extended Reaction Tubes

For Torque Wrench Model Nr.	Model Number	Dimensions (mm)			🏋️ (kg)
		A	B	Ø C	
RSL1500 + RLP	ERT152	157	51	57	0,9
	ERT156	259	152	57	1,6
	ERT159	335	229	57	2,5
	ERT1512	411	305	57	3,4
	ERT1524	716	610	57	6,7
RSL3000 + RLP	ERT3012	429	305	70	3,0
	ERT3024	734	610	70	5,9
RSL5000 + RLP	ERT5012	451	305	89	5,6
	ERT5024	756	610	89	11,3
RSL11000 + RLP	ERT1106	330	152	95	2,1
	ERT11012	483	305	95	4,1
	ERT11018	635	457	95	6,1
	ERT11024	787	610	95	8,4
RSL19000 + RLP	ERT19024	800	610	127	16,7
RSL28000 + RLP	ERT2806	351	152	127	3,6
	ERT28012	503	305	127	7,3
	ERT28018	655	457	127	10,9
	ERT28024	808	610	127	16,6

- Only to be used on RSL-drive units with RLP-hexagon cassettes
- Used in place of standard reaction arm
- One piece steel design, durable and simple
- Increases tool fit in restricted access areas
- Full torque rated.

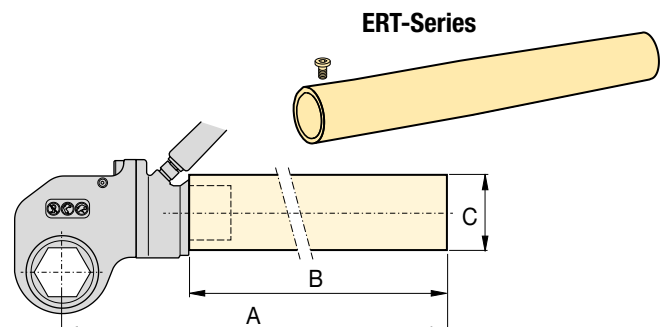

NOTE: Extended Reaction Tubes for RSL8000 are available on request.

▼ RSL-Drive Unit with interchangeable RLP...SL Slimline Hexagon Cassette



Simplicity

- Minimum nose radius for trouble-free tool fit which makes it uniquely equipped to access tight spaces
- Simple robust alloy steel design with three moving parts for reduced maintenance
- Robust handles are available for both sides and the tops of cassettes to allow for extra maneuverability
- Proven to perform even in the harshest environments
- Reaction arm has a simple dial lock for rapid change
- Designed to give optimum strength to weight and torque to weight ratios.

Versatility

- Interchangeable cassette design
- Drive unit / hexagon cassette combination for limited height in line solutions
- Wide range of hexagon sizes available for all applications.

Accuracy

- Constant torque output provides accuracy of $\pm 3\%$ across full stroke.

Ease of Use

- Few moving parts are easily accessible for quick field maintenance
- Innovative design that completely encloses all moving parts and minimizes pinch points.

Setting New Standards in Safety, Simplicity and Performance



Torque Pumps

Visit enerpac.com for system matched air and electric torque pumps that are ideal for use with hydraulic torque wrenches.

Page: 273



Torque Wrench Options and Accessories

Optional accessories are available for maximum versatility. Please contact your Enerpac representative to help you select the optimum solution for your application.

Page: 249



Back-Up Spanners

To be used to stop the back nut from turning during make up or break out. Two hexagon sizes in one tool.

Hexagon Sizes (A/F)		Back-Up Spanner Model Number
mm	inch	
27 - 32	1 ¹ / ₁₆ - 1 ¹ / ₄ "	BUS01
36 - 41	1 ⁷ / ₁₆ - 1 ⁵ / ₈ "	BUS02
46 - 50	1 ¹³ / ₁₆ - 2"	BUS03
55 - 60	2 ³ / ₁₆ - 2 ³ / ₈ "	BUS04
65 - 70	2 ⁹ / ₁₆ - 2 ³ / ₄ "	BUS05
75 - 80	2 ¹⁵ / ₁₆ - 3 ¹ / ₈ "	BUS06
–	3 ¹ / ₂ - 3 ⁷ / ₈ "	BUS07
–	4 ¹ / ₄ - 4 ⁵ / ₈ "	BUS08
85 - 90	–	BUS09
95 - 100	3 ³ / ₄ - 3 ¹⁵ / ₁₆ "	BUS10
105 - 110	4 ¹ / ₈ - 4 ¹⁵ / ₁₆ "	BUS11
115 - 120	–	BUS12

Page: 225

Slimline Stepped-Width Hexagon Cassettes for RSL-Series



Slimline Stepped-Width Hexagon Cassettes

Accessing narrow spaces normally requires significantly reducing the width of the torque wrench. For the tool operator, this has always meant vastly reduced tool durability, and/or reduced torque output.

By using the highest-grade materials and perfecting the geometry, the RSL Slimline cassettes are able to provide greater torque, get into tighter spaces, and vastly outperform the competition in product durability.

RSL Series



Hexagon Range:

1 1/4 - 3 3/16 inch

Hexagon Range:

32 - 80 mm

Maximum Operating Pressure:

690 bar

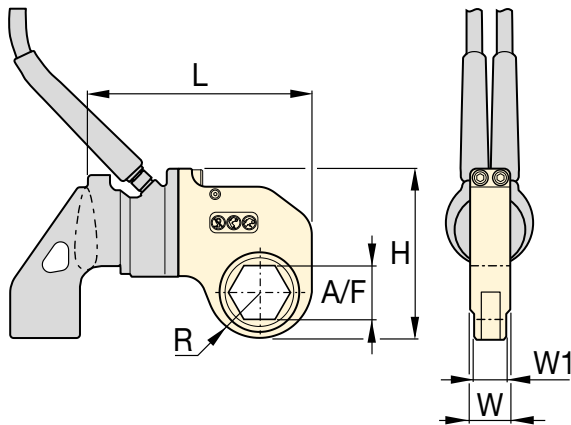

Select the Right Torque

Choose your Enerpac Torque Wrench using the untightening rule of thumb: Loosening torque equals about 250% of tightening torque.

Page: 418



Torque Wrench Hoses

Use Enerpac THQ700-Series torque wrench hoses with RSL-Series torque wrenches to ensure the integrity of your hydraulic system.

Page: 257

▼ SELECTION CHART

Drive Unit Model Number	Hexagon Size A/F		Slimline Hexagon Cassette Model Nr.	Maximum Torque		Dimensions (inch)					Dimensions (mm)						
	(inch)	(mm)		(Ft.lbs)	(Nm)	R	L	W	W1	H	(lbs)	R	L	W	W1	H	(kg)
RSL1500	1 1/4	32	RLP1104SL	375	509	1.03	6.12	1.25	1.00	4.57	2.2	26,2	155,4	31,8	25,4	116,1	1,0
	1 7/16	36	RLP1107SL	658	892	1.15	6.24	1.25	1.00	4.69	2.3	29,2	158,5	31,8	25,4	119,1	1,0
	1 5/8	41	RLP1110SL	831	1127	1.31	6.41	1.25	1.00	4.86	2.7	33,3	162,8	31,8	25,4	123,4	1,2
	1 13/16	46	RLP1113SL	831	1127	1.40	6.49	1.25	1.00	4.94	2.7	35,6	164,8	31,8	25,4	125,5	1,2
	2	50	RLP1200SL	831	1127	1.48	6.58	1.25	1.00	5.03	2.7	37,6	167,1	31,8	25,4	127,8	1,2
RSL3000	2	50	RLP3200SL	1354	1836	1.60	8.04	1.38	1.13	5.92	4.5	40,6	204,2	35,1	28,7	150,4	2,0
	2 3/16	55	RLP3203SL	1604	2175	1.76	8.16	1.38	1.13	6.08	4.7	44,7	207,3	35,1	28,7	154,4	2,1
	2 3/8	60	RLP3206SL	1604	2175	1.84	8.25	1.38	1.13	6.15	4.8	46,7	209,6	35,1	28,7	156,2	2,2
	2 9/16	65	RLP3209SL	1604	2175	1.95	8.14	1.38	1.13	6.26	4.6	49,5	206,8	35,1	28,7	159,0	2,1
	2 3/4	70	RLP3212SL	1604	2175	2.04	8.23	1.38	1.13	6.36	4.4	51,8	209,0	35,1	28,7	161,5	2,0
	2 15/16	75	RLP3215SL	1604	2175	2.16	8.34	1.38	1.13	6.54	4.7	54,9	211,8	35,1	28,7	166,1	2,1
RSL5000	2 3/4	70	RLP5212SL	4173	5659	2.16	9.63	1.75	1.62	7.07	7.5	54,9	244,6	44,5	41,1	179,6	3,4
	3 1/8	80	RLP5302SL	4173	5659	2.26	9.73	1.75	1.62	7.17	7.2	57,4	247,1	44,5	41,1	182,1	3,3
RSL8000	2 9/16	55	RLP8203SL	2487	3372	1.71	9.53	2.25	2.00	6.84	8.5	43,4	242,1	57,2	50,8	173,7	3,9
	2 3/8	60	RLP8206SL	3198	4336	1.87	9.67	2.25	2.00	7.00	8.9	47,5	245,6	57,2	50,8	177,8	4,0
	2 9/16	65	RLP8209SL	4122	5589	2.01	9.67	2.25	2.00	7.13	9.0	51,1	245,6	57,2	50,8	181,1	4,1
	2 3/4	70	RLP8212SL	5587	7576	2.16	9.82	2.25	2.00	7.28	9.6	54,9	249,4	57,2	50,8	184,9	4,4
	2 15/16	75	RLP8215SL	5587	7576	2.24	9.90	2.25	2.00	7.36	9.6	56,9	251,5	57,2	50,8	186,9	4,4
	3 1/8	80	RLP8302SL	5587	7576	2.26	9.92	2.25	2.00	7.39	9.3	57,4	252,0	57,2	50,8	187,7	4,2
	3 3/16	-	RLP8303SL	4740	6427	2.26	9.92	2.25	2.00	7.39	9.3	57,4	252,0	57,2	50,8	187,7	4,2

IMPORTANT: RSL-drive units must be ordered separately to operate the RLP-SL-Hexagon Cassettes.

▼ RSL drive unit with interchangeable RSQ square drive cassette



Safety and Performance

- Innovative design that completely encloses all moving parts and minimizes pinch points
- 30-35° rotation angle provides added productivity while avoiding “tool lock on” which is common with some torque wrench designs.

Simplicity

- Simple robust design with just three moving parts for reduced maintenance
- Robust handles are available for both sides and the tops of cassettes to allow for extra maneuverability
- Pull-type square drive release for quickly reversing the square drive for tightening or loosening.

Versatility

- Square Drive Sets available with Interchangeable Hexagon Cassettes
- Power head / square drive combination for flexible use with standard impact quality sockets
- Reaction arm has a simple dial lock for rapid change.

Accuracy

- Constant torque output provides accuracy of $\pm 3\%$ across full stroke.

Setting New Standards in Safety, Simplicity and Performance



Torque Wrench Options and Accessories

Optional accessories are available for maximum versatility. Please contact your Enerpac representative to help you select the optimum solution for your application.

Page: 249



BSH-Series Sockets

Heavy-Duty Impact Sockets for power driven torquing equipment.

Page: 224



Back-Up Spanners

To be used to stop the back nut from turning during make up or break out. Two hexagon sizes in one tool.

Page: 225



Torque Wrench Hoses

Use Enerpac THQ-Series torque wrench hoses with RSL-Series torque wrenches to ensure the integrity of your hydraulic system.

2 meters long, 2 hoses	THQ702T
6 meters long, 2 hoses	THQ706T
12 meters long, 2 hoses	THQ712T



Torque Pumps

Visit enerpac.com for system matched air and electric torque pumps that are ideal for use with hydraulic torque wrenches.

Page: 273

Square Drive Hydraulic Torque Wrenches

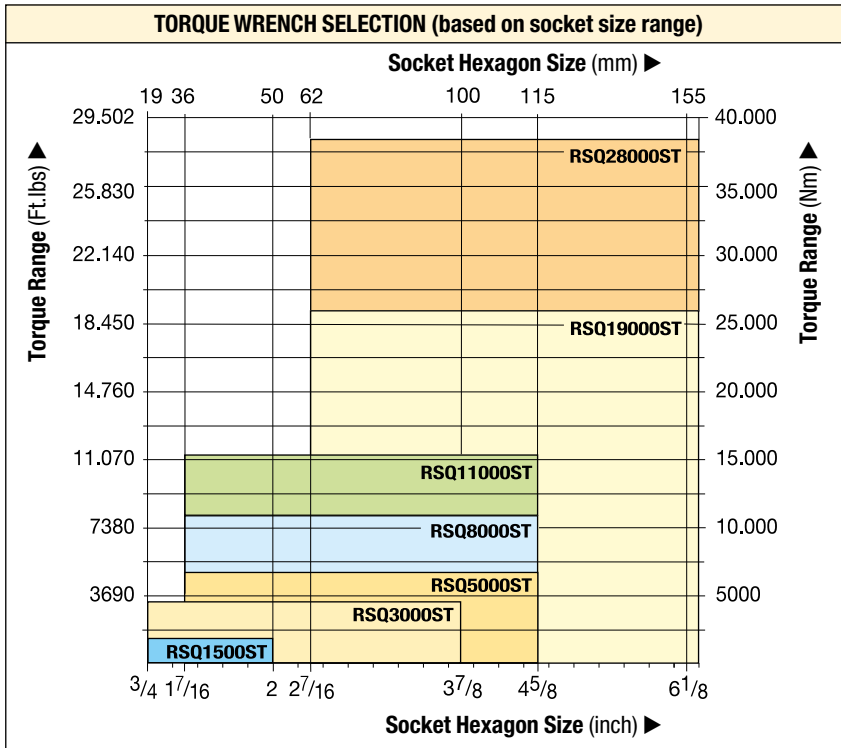

RSL Series



Maximum Torque Output:
1408 - 28.002 Ft.lbs

Maximum Torque Output:
1909 - 37.965 Nm

Square Drive Range:
3/4 - 2 1/2 inch

Maximum Operating Pressure:
690 bar



Select the Right Torque

Choose your Enerpac Torque Wrench using the untightening rule of thumb: Loosening torque equals about 250% of tightening torque.



Safe T™ Torque Lock

The Safe T™ Torque Lock is suitable for all bolted applications from 190 Nm to 15.000 Nm using a heavy duty impact socket.

The patented mechanical locking system creates a hands-free torque wrench solution suitable for Enerpac only square drive tools.

Suitable for RSQ3000, RSQ5000 and RSQ11000.

Page: **226**

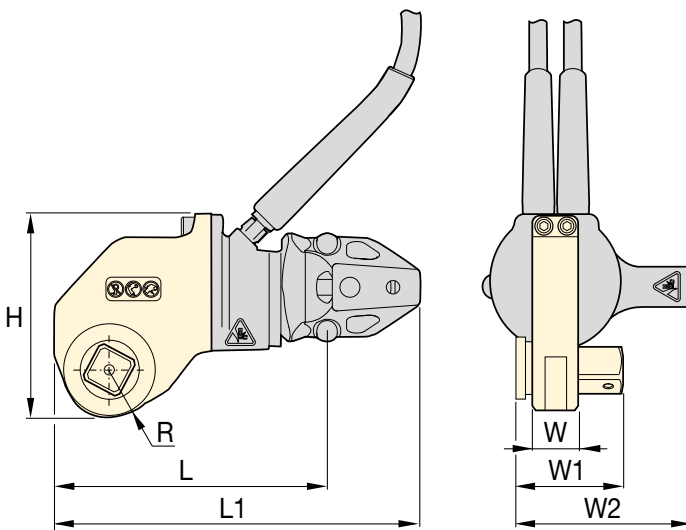

SELECTION CHART

Maximum Torque Output		Square Drive Size (inch)	Square Drive Cassette Model Number ¹⁾	Square Drive Torque Wrench Set Model Number ²⁾	Dimensions (mm)							Weight (kg)		
(Ft.lbs)	(Nm)				W	W1	W2	H	L	L1	R	Drive Unit (without reaction arm)	Reaction Arm	Square Drive Cassette
1408	1909	3/4	RSQ1500	RSQ1500ST	32	58	101	114	160	189	24	1,6	0,5	1,3
3080	4176	1	RSQ3000	RSQ3000ST	38	73	124	141	195	262	32	2,6	1,0	2,4
5303	7190	1 1/2	RSQ5000	RSQ5000ST	45	94	160	163	235	296	39	4,1	1,8	4,1
7862	10.659	1 1/2	RSQ8000	RSQ8000ST	61	105	160	169	241	300	39	4,8	2,0	5,3
11.154	15.123	1 1/2	RSQ11000	RSQ11000ST	64	118	170	201	284	315	48	5,3	3,0	8,4
18.843	25.547	2 1/2	RSQ19000	RSQ19000ST	83	162	265	241	342	482	64	9,1	7,1	13,1
28.002	37.965	2 1/2	RSQ28000	RSQ28000ST	89	166	227	263	358	536	64	10,0	5,0	17,9

¹⁾ When ordering an RSQ Square Drive Cassette, the RSL-Drive Unit must be ordered separately.

²⁾ An RSQ...ST Torque Wrench Set includes RSQ-Square Drive Cassette, RSL-Drive Unit with Hoses and Reaction Arm.

▼ Shown: DSX11000



Safety and Performance

- High-strength, light-weight aluminium, slimline design suited for complete operator safety
- Fully enclosed drive for maximum safety
- Built-in, work-at-height safety tether connection
- Retained quick release push-button
- Patented, easy-to-use, quick release, retained reaction arm
- Fine tooth ratchet prevents the tool 'locking on'
- High-cycle design with fewer moving parts making it a more efficient tool to operate, maintain or repair
- 35° rotation angle and rapid return stroke for fast operation.

Simplicity

- Includes a robust handle or handle with lifting eye which mounts on either side of the tool for extra maneuverability and safer operation
- Push-button square drive and reaction arm for fast changes and adjustments
- Easily accessible work-at-height connection point.

Accuracy

- Constant torque output provides accuracy of $\pm 3\%$ across full stroke.

ATEX declared

- All DSX tools are CE - ATEX declared.

Setting Industry-First Safety Standards



Work-at-Height Connection

Built-in, work-at-height safety tether connection.



Fully Retained Reaction Arm

Patented, fully retained reaction arm with easy-to-use quick release, helps prevent injuries when working-at-height.



Secured Square Drive

Retained quick release push-button.



Ergonomic Tool Handle

Robust ergonomic positioning handle or eyebolt handle comes supplied as standard with every DSX tool. The SWH10EA is a handle with lifting eye for DSX25000.

Compatible DSX-Series wrenches	Model Nr. Handle or Lifting Eye
DSX1500, 3000, 5000	SWH6A
DSX11000	SWH10A
DSX25000	SWH10EA



Bolting Integrity Software

Enerpac Bolting Integrity Software Solutions play a key role in

implementing and managing an Integrity Program for bolted connections.

The software offers Tool selection, Bolt Load calculations and Tool pressure settings, as well as a combined Application Data Sheet and Joint Completion Report.

Custom Joint information can also be entered.

Square Drive Hydraulic Torque Wrenches

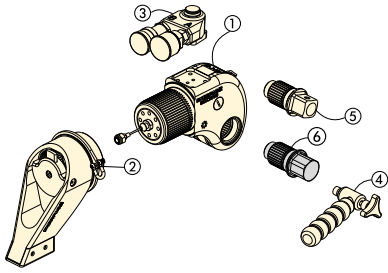

Standard are: ① ② ③ ④ ⑤

Item ⑥ is optional.

- ① Drive Unit
- ② Reaction Arm
- ③ Hose Swivel
- ④ Ergonomic Tool Handle
- ⑤ Square Drive
- ⑥ Allen Key-Drive (option)

Select the Right Torque
Choose your Enerpac Torque Wrench using the untightening rule of thumb:
Loosening torque equals about 250% of tightening torque.

Page: **419**

DSX Series



Nominal Torque Output:

32.617 Nm | 24.057 Ft.lbs

Square Drive Range:

3/4 - 2 1/2 inch

Nose Radius:

24 - 64 mm

Maximum Operating Pressure:

690 bar

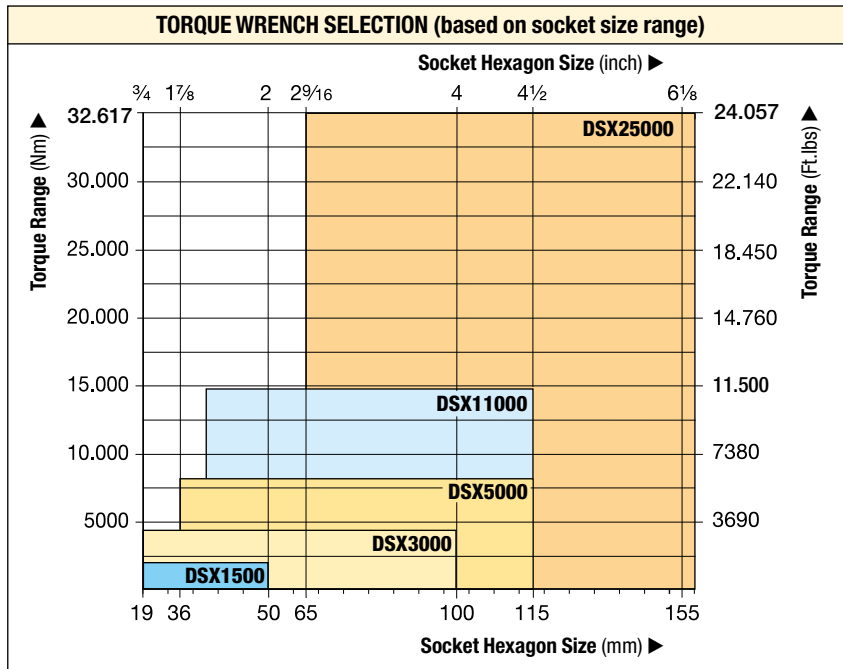

Back-Up Spanners

Hands-free tool to be used to stop the back nut from turning during make up or break out.

Page: **225**

▼ The rigid design of the DSX-Series torque wrenches provides durability, reliability and safety.



BSH-Series Sockets
Use only Heavy-Duty Impact Sockets for power driven torquing equipment.

Page: **224**

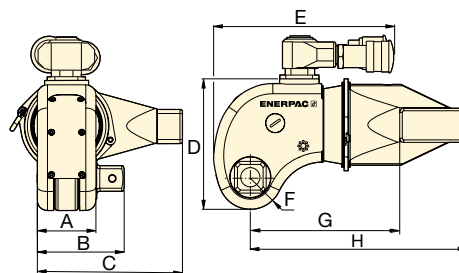

Nominal Torque at 690 bar		Minimum Torque at 69 bar		Square Drive Size (inch)	Torque Wrench Model Number	Dimensions (mm)								(kg)	
(Nm)	(Ft.lbs)	(Nm)	(Ft.lbs)			Model Nr. (included with wrench)	A	B	C	D	E	F	G		H
1913	1411	191	141	3/4	DSX1500-08	DSX1500	44	67	107	96	145	24	114	163	2,2
4383	3233	438	323	1	DSX3000-08	DSX3000	58	86	144	129	171	32	148	215	4,8
7640	5635	764	563	1 1/2	DSX5000-08	DSX5000	69	112	173	148	192	38	180	260	8,1
14.914	11.000	1491	1100	1 1/2	DSX11000-08	DSX11000	87	129	215	181	222	48	227	325	14,4
32.617	24.057	3262	2406	2 1/2	DSX25000-08	DSX25000	117	176	288	244	266	64	281	426	32,5

Maximum Torque Output:

32.617 Nm

Hexagon Size Allen Drive:

1/2 - 2 1/4 inch

Hexagon Size Allen Drive:

14 - 85 mm

For
DSX
Series



Torque Wrench	Optional Allen-Key Drives, Imperial				Optional Allen-Key Drives, Metric			
	Hexagon Size	Maximum Torque	Model Number	Dim.	Hexagon Size	Maximum Torque	Model Number	Dim.
(max. torque)	(inch)	(Ft.Lbs)		B1 (mm)	(mm)	(Nm)		B1 (mm)
 DSX1500 (1411 Ft.lbs) (1913 Nm)	1/2	350	DDA15008	67	14	644	DDA1514	67
	5/8	690	DDA15010	67	17	1152	DDA1517	67
	3/4	1200	DDA15012	67	19	1627	DDA1519	67
	7/8	1411	DDA15014	67	22	1913	DDA1522	67
	1	1411	DDA15100	67	24	1913	DDA1524	67
DSX3000 (3233 Ft.lbs) (4383 Nm)	5/8	690	DDA30010	86	17	1152	DDA3017	86
	3/4	1200	DDA30012	86	19	1627	DDA3019	86
	7/8	1900	DDA30014	86	22	2495	DDA3022	86
	1	2830	DDA30100	86	24	3376	DDA3024	86
	1 1/8	3233	DDA30102	86	27	4383	DDA3027	86
	1 1/4	3233	DDA30104	86	30	4383	DDA3030	86
	-	-	-	86	32	4383	DDA3032	86
DSX5000 (5635 Ft.lbs) (7640 Nm)	5/8	690	DDA50010	112	17	1152	DDA5017	112
	3/4	1200	DDA50012	112	19	1627	DDA5019	112
	7/8	1900	DDA50014	112	22	2495	DDA5022	112
	1	2830	DDA50100	112	24	3376	DDA5024	112
	1 1/8	5325	DDA50102	112	27	4610	DDA5027	112
	1 1/4	5635	DDA50104	112	30	7640	DDA5030	112
	-	-	-	-	32	7640	DDA5032	112
DSX11000 (11.000 Ft.lbs) (14.914 Nm)	1 1/4	5635	DDA110104	129	30	7640	DDA11030	129
	1 3/8	9958	DDA110106	129	32	7640	DDA11032	129
	1 1/2	9958	DDA110108	129	36	10.846	DDA11036	129
	1 5/8	11.000	DDA110110	129	41	14.914	DDA11041	129
	1 3/4	11.000	DDA110112	129	46	14.914	DDA11046	129
DSX25000 (24.057 Ft.lbs) (32.617 Nm)	1 1/2	9958	DDA250104	176	36	10.846	DDA25036	176
	1 5/8	16.433	DDA250106	176	41	16.107	DDA25041	176
	1 3/4	15.200	DDA250112	176	46	22.777	DDA25046	176
	1 7/8	22.777	DDA250114	176	50	29.211	DDA25050	176
	2	24.057	DDA250200	176	55	32.617	DDA25055	176
	2 1/4	24.057	DDA250204	176	60	32.617	DDA25060	176
	-	-	-	-	65	32.617	DDA25065	176
	-	-	-	-	70	32.617	DDA25070	176
	-	-	-	-	75	32.617	DDA25075	176
	-	-	-	-	85	32.617	DDA25085	176

▼ THQ706T



THQ Series

Hose Lengths:

2, 6 and 12 metres

Maximum Operating Pressure:

700 bar

Twin Torque Wrench Hose

- Thermo-plastic safety dual hoses
- For use S, W, RSL, DSX and HMT-Series torque wrenches and 700 bar torque pumps
- With 1/4" Spin-on Torque Wrench Couplers
- For demanding applications, featuring a 4:1 safety factor
- Maximum working pressure of 700 bar
- Outside jacket is polyurethane, to provide maximum abrasion resistance
- Low volumetric expansion under pressure to enhance overall system efficiency
- Crimped-on vinyl strain relief for improved life and durability on all models.

Use the THQ-Series hoses with Enerpac torque wrenches and pumps to ensure the integrity of your hydraulic system. ▶



HT, B-Series, 1500 bar Hoses and Fittings for Tensioning

Bolt tensioning equipment require different hoses, couplers and fittings than torque wrenches and pumps.

Page: 309



Premium Hydraulic Oil

Use only genuine Enerpac hydraulic oil. Wrong fluid can destroy seals and pump and will render your warranty null and void your guarantee.

Page: 132



Internal Diameter (mm)	Hose Length (m)	Model Number	Maximum Operating Pressure (bar)	Hose Ends 1/4" Spin-on Torque Wrench Couplers		Weight (kg)
				Hose one	Hose two	
6,4	2,0	THQ702T	700	female half TR630 + male half TH630	male half TH630 + female half TR630	2,2
	6,0	THQ706T	700	female half TR630 + male half TH630	male half TH630 + female half TR630	4,5
	12,0	THQ712T	700	female half TR630 + male half TH630	male half TH630 + female half TR630	7,6

▼ HMT-Drive Units with interchangeable HLP-Low-Profile Cassette and HSQ-Square Drive Cassette



The HMT-Series is a range of fast, durable and efficient modular hydraulic torque wrenches, enabling you to tackle almost any bolting application. Interchange cassettes with ease, switching the HLP low profile hexagon cassette with the HSQ square drive whenever your application demands.

As an added benefit, tools and cassettes are interchangeable with many other well-known brands, allowing you the freedom to use the tools at your disposal whilst reducing the cost of upgrading your legacy torque wrench inventory to high quality Enerpac equipment.

The tool itself has been carefully designed and manufactured, utilising superior alloys and surface treatments to make it lightweight, up to 25% faster and more than twice as durable as other tools in the same class.

Safety and Performance

- Supplied with an ergonomic tool safety handle as standard
- The HMT Modular Torque/Tool is also supplied with a link pin retainer as standard.

Versatility

- Interchangeable with other manufacturers
- HMT is able to solve all of your bolting challenges quickly and safely, with one or more attachment options, making it suitable for any application.

Simplicity

- The HMT is part of a modular system which is made up of a single power head and one attachment; the HMT-Drive Unit and HLP-Hexagon Cassette or HSQ-Square Drive Cassette.

Accuracy

- Constant torque output provides accuracy of $\pm 3\%$ across full stroke.

Modular, Durable, Fast and Efficient Torque for Low-Profile and Square Drive Applications



Bolting Integrity Software

The software offers Tool selection, Bolt Load calculations and Tool pressure settings, as well as, a combined Application Data Sheet and Joint Completion Report. Custom Joint information can also be entered.

Page: 422



Back-Up Spanners

To be used to stop the back nut from turning during make up or break out. Two hexagon sizes in one tool.

Page: 225



Torque Pumps

Visit enerpac.com for system matched air and electric torque pumps that are ideal for use with hydraulic torque wrenches.

Page: 273



Torque Wrench Hoses

Use Enerpac THQ-Series hoses with HMT-Series torque wrenches to ensure the integrity of your hydraulic system. See page 257.

2 m long, 2 hoses	THQ702T
6 m long, 2 hoses	THQ706T
12 m long, 2 hoses	THQ712T

Drive Units for Hexagon & Square Drive Cassettes



One Drive, Two Tools

One HMT-Hydraulic Torque Wrench fits HLP-Low-Profile or HSQ Square Drive cassette.

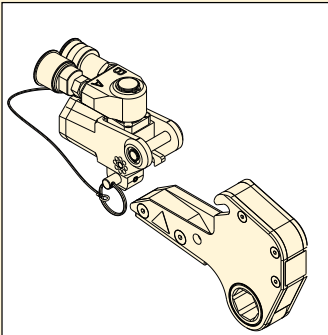

HMT...HLP

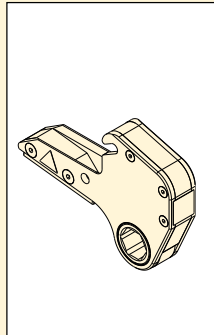

HLP

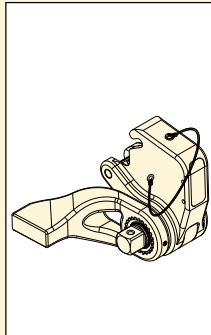

HSQ

HMT Series



Maximum Torque at 10.000 psi:

1541 - 13.489 Ft.lbs

Maximum Torque at 690 bar:

2089 - 18.289 Nm

Hexagon Range:

1 1/16" - 4 5/8" / 26 - 115 mm

Maximum Operating Pressure:

690 bar / 10.000 psi

HMT-Series, Torque Wrench Options and Accessories

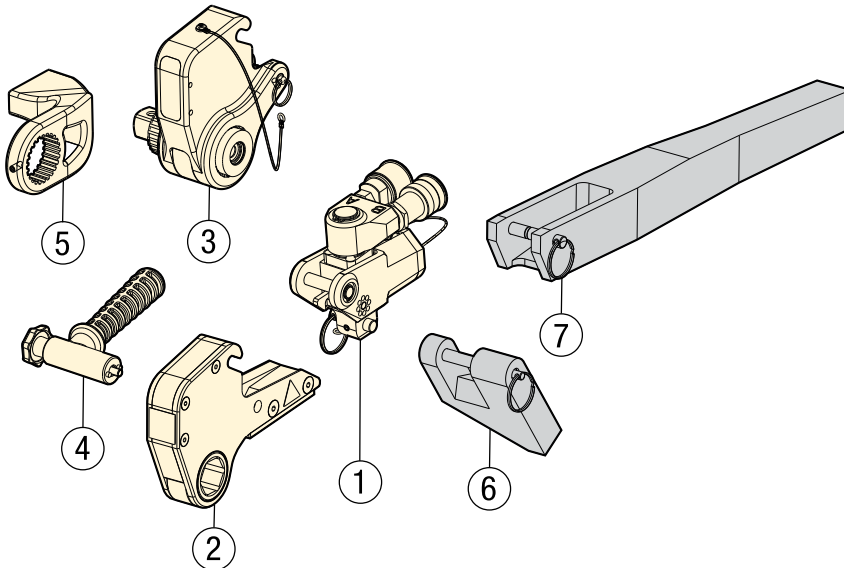

① HMT: Drive Unit (page 259)

② HLP: Hexagon Cassette (page 260-261)

③ HSQ: Square Drive Cassette (page 262-263)

④ SWH: Ergonomic Tool Handle (page 262)

⑤ Reaction Arm for HSQ

Optional Parts (for HMT with HLP only)

⑥ HRP: Reaction Paddle (page 260)

⑦ HTE: Extended Reaction Arm (page 260)



Select the Right Torque

Choose your Enerpac Torque Wrench using the untightening rule of thumb: Loosening torque equals about 250% of tightening torque.



HLP Low-Profile Cassettes

For the metric and imperial Low-Profile hexagon cassettes see:

Page: 260



HSQ Square Drive Cassettes

For the metric and inch Square Drive Cassettes see:

Page: 262

▼ SELECTION CHART DRIVE UNITS FOR HEXAGON & SQUARE DRIVE CASSETTES

Maximum Torque Output at 690 bar		Minimum Torque Output at 69 bar		Drive Unit Model Number 	Dimensions (inch)				Dimensions (mm)			
(Ft.lbs)	(Nm)	(Ft.lbs)	(Nm)		A	B	C	(lbs)	A	B	C	(kg)
1541	2089	154	209	HMT1500	4.3	4.1	2.0	2.20	108	104	49	1,0
3750	5084	375	508	HMT3500	5.7	5.2	2.6	3.97	146	132	66	1,8
7562	10.252	756	1025	HMT7500	7.1	6.4	3.2	7.05	180	163	82	3,2
13.489	18.289	1349	1829	HMT13000*	8.5	7.4	3.9	4.40	216	187	98	9,7

* Note: HMT13000 only available for HLP-low-profile hexagon cassettes.

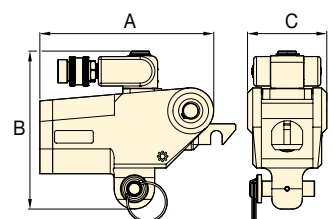

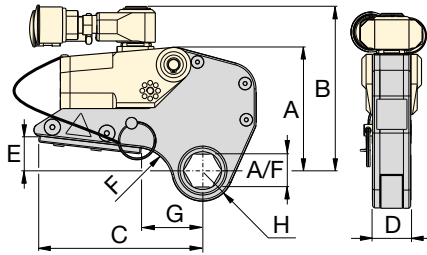

Hexagon Range:
1 1/16 - 4 5/8 inch

Hexagon Range:
26 - 115 mm

Maximum Operating Pressure:
690 bar / 10.000 psi

**HLP
Series**



▼ **SELECTION CHART**

IMPORTANT: HMT-drive units must be ordered separately to operate the HLP-Hexagon Cassettes.

Drive Unit Model Number	Hexagon Size A/F		Hexagon Cassette Model Number	Maximum Torque		Dimensions (inch)										Weight (lbs)	Dimensions (mm)								Weight (kg)
	(inch)	(mm)		(Ft.lbs)	(Nm)	A	B	C	D	E	F	G	H	(lbs)	A	B	C	D	E	F	G	H	(kg)		
																					(kg)				
HMT1500	1 1/16	26	HLP1101	1541	2089	4.48	5.32	5.35	1.2	1.13	1.18	2.01	1.00	3.53	114	135	136	31.5	29	30	51	25	1.6		
	1 1/8	-	HLP1102	1541	2089	4.48	5.32	5.35	1.2	1.13	1.18	2.01	1.00	3.53	114	135	136	31.5	29	30	51	25	1.6		
	1 3/16	30	HLP1103	1541	2089	4.48	5.32	5.35	1.2	1.13	1.18	2.01	1.00	3.53	114	135	136	31.5	29	30	51	25	1.6		
	1 1/4	32	HLP1104	1541	2089	4.48	5.32	5.35	1.2	1.13	0.95	2.01	1.08	3.53	114	135	136	31.5	29	24	51	27	1.6		
	1 5/16	33	HLP1105	1541	2089	4.48	5.32	5.35	1.2	1.13	0.95	2.01	1.08	3.53	114	135	136	31.5	29	24	51	27	1.6		
	1 3/8	35	HLP1106	1541	2089	4.48	5.32	5.35	1.2	1.13	0.55	1.89	1.19	3.53	114	135	136	31.5	29	14	48	30	1.6		
	1 1/2	36	HLP1107	1541	2089	4.48	5.32	5.35	1.2	1.13	0.55	1.89	1.19	3.53	114	135	136	31.5	29	14	48	30	1.6		
	1 5/8	38	HLP1108	1541	2089	4.48	5.32	5.35	1.2	1.13	0.55	2.01	1.30	3.53	114	135	136	31.5	29	14	51	33	1.6		
	1 3/4	-	HLP1109	1541	2089	4.48	5.32	5.35	1.2	1.13	0.55	2.01	1.30	3.53	114	135	136	31.5	29	14	51	33	1.6		
	1 7/8	41	HLP1110	1541	2089	4.48	5.32	5.35	1.2	1.13	0.55	2.01	1.30	3.53	114	135	136	31.5	29	14	51	33	1.6		
	2	-	HLP1111	1541	2089	4.48	5.32	5.35	1.2	1.13	0.55	2.01	1.30	3.53	114	135	136	31.5	29	14	51	33	1.6		
	2 1/16	46	HLP1112	1541	2089	4.48	5.32	5.35	1.2	1.13	0.55	2.01	1.38	3.53	114	135	136	31.5	29	14	51	35	1.6		
	2 1/8	-	HLP1113	1541	2089	4.48	5.32	5.35	1.2	1.13	0.55	2.01	1.38	3.53	114	135	136	31.5	29	14	51	35	1.6		
	2 3/16	46	HLP1113	1541	2089	4.48	5.32	5.35	1.2	1.13	0.55	2.01	1.38	3.53	114	135	136	31.5	29	14	51	35	1.6		
	2 1/4	-	HLP1114	1541	2089	4.48	5.32	5.35	1.2	1.13	0.55	2.36	1.52	3.53	114	135	136	31.5	29	14	60	39	1.6		
	2 5/16	-	HLP1115	1541	2089	4.48	5.32	5.35	1.2	1.13	0.55	2.36	1.52	3.53	114	135	136	31.5	29	14	60	39	1.6		
	2 3/8	50	HLP1200	1541	2089	4.48	5.32	5.35	1.2	1.13	0.55	2.36	1.52	3.75	114	135	136	31.5	29	14	60	39	1.7		
	2 1/2	-	HLP1201	1541	2089	4.48	5.32	5.35	1.2	1.13	0.55	2.36	1.52	3.75	114	135	136	31.5	29	14	60	39	1.7		
	2 5/8	-	HLP1202	1541	2089	4.48	5.32	5.35	1.2	1.13	0.55	2.36	1.65	3.75	114	135	136	31.5	29	14	60	42	1.7		
	2 3/4	55	HLP1203	1541	2089	4.48	5.32	5.35	1.2	1.13	0.55	2.36	1.65	3.75	114	135	136	31.5	29	14	60	42	1.7		
	2 7/8	-	HLP1204	1541	2089	4.48	5.32	5.35	1.2	1.13	0.55	2.36	1.65	3.75	114	135	136	31.5	29	14	60	42	1.7		
	3	-	HLP1205	1541	2089	4.48	5.32	5.35	1.2	1.13	0.55	2.36	1.65	3.75	114	135	136	31.5	29	14	60	42	1.7		
	3 1/16	60	HLP1206	1541	2089	4.48	5.32	5.35	1.2	1.13	0.55	2.36	1.71	3.75	114	135	136	31.5	29	14	60	44	1.7		
	3 1/8	-	HLP1207	1541	2089	4.48	5.32	5.35	1.2	1.13	0.55	2.36	1.71	3.75	114	135	136	31.5	29	14	60	44	1.7		
	HMT3500	1 3/8	35	HLP3106	3750	5084	6.02	6.57	7.24	1.7	1.59	1.89	3.09	1.30	8.60	153	167	184	42.0	41	48	79	33	3.9	
		1 1/2	36	HLP3107	3750	5084	6.02	6.57	7.24	1.7	1.59	1.89	3.09	1.30	8.60	153	167	184	42.0	41	48	79	33	3.9	
		1 3/4	38	HLP3108	3750	5084	6.02	6.57	7.24	1.7	1.59	1.81	3.16	1.42	8.60	153	167	184	42.0	41	46	80	36	3.9	
		1 5/8	-	HLP3109	3750	5084	6.02	6.57	7.24	1.7	1.59	1.81	3.16	1.42	8.60	153	167	184	42.0	41	46	80	36	3.9	
		1 7/8	41	HLP3110	3750	5084	6.02	6.57	7.24	1.7	1.59	1.81	3.16	1.42	8.60	153	167	184	42.0	41	46	80	36	3.9	
		2	-	HLP3111	3750	5084	6.02	6.57	7.24	1.7	1.59	1.81	3.16	1.42	8.60	153	167	184	42.0	41	46	80	36	3.9	
		2 1/16	46	HLP3112	3750	5084	6.02	6.57	7.24	1.7	1.59	1.58	3.08	1.52	8.60	153	167	184	42.0	41	40	78	39	3.9	
2 1/8		-	HLP3113	3750	5084	6.02	6.57	7.24	1.7	1.59	1.58	3.08	1.52	8.60	153	167	184	42.0	41	40	78	39	3.9		
2 3/16		46	HLP3113	3750	5084	6.02	6.57	7.24	1.7	1.59	1.58	3.08	1.52	8.60	153	167	184	42.0	41	40	78	39	3.9		
2 1/4		-	HLP3114	3750	5084	6.02	6.57	7.24	1.7	1.59	1.42	3.05	1.63	8.60	153	167	184	42.0	41	36	77	41	3.9		
2 5/16		-	HLP3115	3750	5084	6.02	6.57	7.24	1.7	1.59	1.42	3.05	1.63	8.60	153	167	184	42.0	41	36	77	41	3.9		
2 3/8		50	HLP3200	3750	5084	6.02	6.57	7.24	1.7	1.59	1.42	3.05	1.63	8.60	153	167	184	42.0	41	36	77	41	3.9		
2 1/2		-	HLP3201	3750	5084	6.02	6.57	7.24	1.7	1.59	1.42	3.05	1.63	8.82	153	167	184	42.0	41	36	77	41	4.0		
2 5/8		-	HLP3202	3750	5084	6.02	6.57	7.24	1.7	1.59	1.18	2.97	1.74	8.82	153	167	184	42.0	41	30	75	44	4.0		
2 3/4		55	HLP3203	3750	5084	6.02	6.57	7.24	1.7	1.59	1.18	2.97	1.74	8.82	153	167	184	42.0	41	30	75	44	4.0		
2 7/8		-	HLP3204	3750	5084	6.02	6.57	7.24	1.7	1.59	1.18	2.97	1.74	8.82	153	167	184	42.0	41	30	75	44	4.0		
3		-	HLP3205	3750	5084	6.02	6.57	7.24	1.7	1.59	0.63	2.68	1.85	9.04	153	167	184	42.0	41	16	68	47	4.1		
3 1/16		60	HLP3206	3750	5084	6.02	6.57	7.24	1.7	1.59	0.63	2.68	1.85	9.04	153	167	184	42.0	41	16	68	47	4.1		
3 1/8		62	HLP3207	3750	5084	6.02	6.57	7.24	1.7	1.59	0.63	2.80	1.85	9.04	153	167	184	42.0	41	16	71	47	4.1		
3 3/8		63	HLP3208	3750	5084	6.02	6.57	7.24	1.7	1.59	0.63	2.80	1.96	9.04	153	167	184	42.0	41	16	71	50	4.1		
3 1/2		65	HLP3209	3750	5084	6.02	6.57	7.24	1.7	1.59	0.63	2.80	1.96	9.04	153	167	184	42.0	41	16	71	50	4.1		
3 5/8		-	HLP3210	3750	5084	6.02	6.57	7.24	1.7	1.59	0.63	2.80	2.07	9.04	153	167	184	42.0	41	16	71	53	4.1		
3 3/4		-	HLP3211	3750	5084	6.02	6.57	7.24	1.7	1.59	0.63	2.80	2.07	9.04	153	167	184	42.0	41	16	71	53	4.1		
4		70	HLP3212	3750	5084	6.02	6.57	7.24	1.7	1.59	0.63	2.80	2.07	9.04	153	167	184	42.0	41	16	71	53	4.1		
4 1/16		-	HLP3213	3750	5084	6.02	6.57	7.24	1.7	1.59	0.63	2.80	2.07	9.04	153	167	184	42.0	41	16	71	53	4.1		
4 1/8		-	HLP3214	3750	5084	6.02	6.57	7.24	1.7	1.59	0.63	2.80	2.07	9.04	153	167	184	42.0	41	16	71	53	4.1		
4 3/8		75	HLP3215	3750	5084	6.02	6.57	7.24	1.7	1.59	0.63	2.99	2.19	9.04	153	167	184	42.0	41	16	76	56	4.1		
4 1/2		3	-	HLP3300	3750	5084	6.02	6.57	7.24	1.7	1.59	0.63	2.99	2.19	9.04	153	167	184	42.0	41	16	76	56	4.1	
4 5/8		3 1/16	-	HLP3301	3750	5084	6.02	6.57	7.24	1.7	1.59	0.63	2.99	2.19	9.04	153	167	184	42.0	41	16	76	56	4.1	
4 3/4		80	HLP3302	3750	5084	6.02	6.57	7.24	1.7	1.59	0.63	2.99	2.19	9.04	153	167	184	42.0	41	16	76	56	4.1		

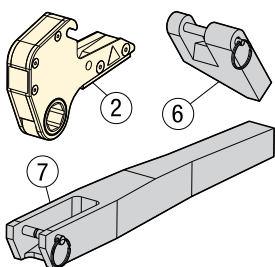

Optional Parts for HLP-Hexagon Cassettes

- Full torque rated
- Includes pin to secure onto HLP-cassette
- **6** HRP: allows offset reaction when in-line reaction point is not available
- **7** HTE: Increases tool fit in restricted areas.

For HMT with HLP-Series Hexagon Cassettes	Reaction Paddle Model Nr. 6	Extended Reaction Arm Model Nr. 7
HMT1500 + HLP1	HRP15	HTE15
HMT3500 + HLP3	HRP35	HTE35
HMT7500 + HLP7	HRP75	HTE75
HMT13000 + HLP13	HRP130	HTE130

Hexagon Cassettes for HMT Drive Units

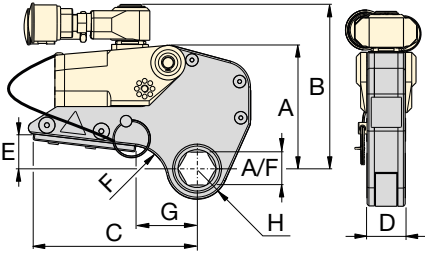

Hexagon Range:
1 1/16 - 4 5/8 inch

Hexagon Range:
26 - 115 mm

Maximum Operating Pressure:
690 bar / 10.000 psi

HLP
Series



▼ SELECTION CHART

IMPORTANT: HMT-drive units must be ordered separately to operate the HLP-Hexagon Cassettes.

Drive Unit Model Number	Hexagon Size A/F		Hexagon Cassette Model Number	Maximum Torque		Dimensions (inch)									⚖️	Dimensions (mm)								⚖️																						
	(inch)	(mm)		(Ft.lbs)	(Nm)	A	B	C	D	E	F	G	H	(lbs)		A	B	C	D	E	F	G	H		(kg)																					
HMT7500																								2 3/16	55	HLP7203	7562	10.252	7.60	8.01	8.94	2.1	1.81	1.65	3.39	1.91	15.65	193	203	227	52,6	46	42	86	49	7,1
																								2 1/4	-	HLP7204	7562	10.252	7.60	8.01	8.94	2.1	1.81	1.65	3.39	1.91	15.65	193	203	227	52,6	46	42	86	49	7,1
																								2 5/16	-	HLP7205	7562	10.252	7.60	8.01	8.94	2.1	1.81	1.65	3.39	1.91	15.65	193	203	227	52,6	46	42	86	49	7,1
																								2 3/8	60	HLP7206	7562	10.252	7.60	8.01	8.94	2.1	1.81	1.18	3.15	1.99	15.65	193	203	227	52,6	46	30	80	51	7,1
																								2 7/16	62	HLP7207	7562	10.252	7.60	8.01	8.94	2.1	1.81	1.18	3.15	1.99	15.65	193	203	227	52,6	46	30	80	51	7,1
																								2 1/2	63	HLP7208	7562	10.252	7.60	8.01	8.94	2.1	1.81	1.18	3.15	1.99	15.65	193	203	227	52,6	46	30	80	51	7,1
																								2 9/16	65	HLP7209	7562	10.252	7.60	8.01	8.94	2.1	1.81	0.87	3.15	2.07	15.65	193	203	227	52,6	46	22	80	53	7,1
																								2 5/8	-	HLP7210	7562	10.252	7.60	8.01	8.94	2.1	1.81	0.79	3.15	2.19	15.65	193	203	227	52,6	46	20	80	56	7,1
																								2 1 1/16	-	HLP7211	7562	10.252	7.60	8.01	8.94	2.1	1.81	0.79	3.15	2.19	15.65	193	203	227	52,6	46	20	80	56	7,1
																								2 3/4	70	HLP7212	7562	10.252	7.60	8.01	8.94	2.1	1.81	0.79	3.15	2.19	17.42	193	203	227	52,6	46	20	80	56	7,9
																								2 13/16	-	HLP7213	7562	10.252	7.60	8.01	8.94	2.1	1.81	0.79	3.15	2.19	17.42	193	203	227	52,6	46	20	80	56	7,9
																								2 7/8	-	HLP7214	7562	10.252	7.60	8.01	8.94	2.1	1.81	0.79	3.15	2.19	17.42	193	203	227	52,6	46	20	80	56	7,9
																								2 15/16	75	HLP7215	7562	10.252	7.60	8.01	8.94	2.1	1.81	0.67	3.15	2.26	17.42	193	203	227	52,6	46	17	80	58	7,9
																								3	-	HLP7300	7562	10.252	7.60	8.01	8.94	2.1	1.81	0.67	3.39	2.38	17.42	193	203	227	52,6	46	17	86	61	7,9
																								3 1/16	-	HLP7301	7562	10.252	7.60	8.01	8.94	2.1	1.81	0.67	3.39	2.38	17.42	193	203	227	52,6	46	17	86	61	7,9
																								3 1/8	80	HLP7302	7562	10.252	7.60	8.01	8.94	2.1	1.81	0.67	3.39	2.38	17.42	193	203	227	52,6	46	17	86	61	7,9
																								3 1/4	-	HLP7304	7562	10.252	7.60	8.01	8.94	2.1	1.81	0.67	3.39	2.52	17.42	193	203	227	52,6	46	17	86	64	7,9
																								-	85	HLP7085M	7562	10.252	7.60	8.01	8.94	2.1	1.81	0.67	3.39	2.52	17.42	193	203	227	52,6	46	17	86	64	7,9
																								3 5/8	-	HLP7306	7562	10.252	7.60	8.01	8.94	2.1	1.81	0.67	3.39	2.52	17.42	193	203	227	52,6	46	17	86	64	7,9
																								3 7/16	-	HLP7307	7562	10.252	7.60	8.01	8.94	2.1	1.81	0.67	3.50	2.52	17.64	193	203	227	52,6	46	17	89	64	8,0
																								3 1/2	-	HLP7308	7562	10.252	7.60	8.01	8.94	2.1	1.81	0.67	3.50	2.64	17.64	193	203	227	52,6	46	17	89	67	8,0
																								-	90	HLP7090M	7562	10.252	7.60	8.01	8.94	2.1	1.81	0.67	3.74	2.64	17.64	193	203	227	52,6	46	17	95	67	8,0
																								3 9/16	-	HLP7309	7562	10.252	7.60	8.01	8.94	2.1	1.81	0.67	3.74	2.78	17.64	193	203	227	52,6	46	17	95	71	8,0
																								3 3/4	95	HLP7312	7562	10.252	7.60	8.01	8.94	2.1	1.81	0.67	3.74	2.89	18.08	193	203	227	52,6	46	17	95	71	8,2
3 5/8	-	HLP7314	7562	10.252	7.60	8.01	8.94	2.1	1.81	0.67	3.74	2.89	18.08	193	203	227	52,6	46	17	95	74	8,2																								
3 15/16	100	HLP7315	7562	10.252	7.60	8.01	8.94	2.1	1.81	0.67	3.74	2.89	18.08	193	203	227	52,6	46	17	95	74	8,2																								
HMT13000																								2 7/16	62	HLP13207	13.489	18.289	8.03	9.53	10.87	2.50	2.25	2.95	4.69	2.28	24.3	204	242	276	63,4	57	75	119	58,0	11,0
																								2 1/2	63	HLP13208	13.489	18.289	8.03	9.53	10.87	2.50	2.25	2.95	4.69	2.28	24.3	204	242	276	63,4	57	75	119	58,0	11,0
																								2 9/16	65	HLP13209	13.489	18.289	8.03	9.53	10.87	2.50	2.25	2.95	4.69	2.28	24.3	204	242	276	63,4	57	75	119	58,0	11,0
																								2 5/8	67	HLP13210	13.489	18.289	8.03	9.53	10.87	2.50	2.25	2.95	4.69	2.28	24.3	204	242	276	63,4	57	75	119	58,0	11,0
																								2 1 1/16	68	HLP13211	13.489	18.289	8.03	9.53	10.87	2.50	2.25	2.95	4.69	2.28	24.3	204	242	276	63,4	57	75	119	58,0	11,0
																								2 3/4	70	HLP13212	13.489	18.289	8.03	9.53	10.87	2.50	2.25	2.95	4.69	2.28	24.3	204	242	276	63,4	57	75	119	58,0	11,0
																								2 13/16	71	HLP13213	13.489	18.289	8.03	9.53	10.87	2.50	2.25	2.95	4.69	2.28	24.3	204	242	276	63,4	57	75	119	58,0	11,0
																								2 7/8	73	HLP13214	13.489	18.289	8.03	9.53	10.87	2.50	2.25	2.95	4.69	2.28	24.3	204	242	276	63,4	57	75	119	58,0	11,0
																								2 15/16	75	HLP13215	13.489	18.289	8.03	9.53	10.87	2.50	2.25	2.76	4.69	2.40	24.3	204	242	276	63,4	57	70	119	61,0	11,0
																								3	77	HLP13300	13.489	18.289	8.03	9.53	10.87	2.50	2.25	2.76	4.88	2.56	24.3	204	242	276	63,4	57	70	124	65,0	11,0
																								3 1/16	78	HLP13301	13.489	18.289	8.03	9.53	10.87	2.50	2.25	2.76	4.88	2.56	24.3	204	242	276	63,4	57	70	124	65,0	11,0
																								3 1/8	80	HLP13302	13.489	18.289	8.03	9.53	10.87	2.50	2.25	2.76	4.88	2.56	24.3	204	242	276	63,4	57	70	124	65,0	11,0
																								3 3/16	81	HLP13303	13.489	18.289	8.03	9.53	10.87	2.50	2.25	2.76	4.88	2.58	24.3	204	242	276	63,4	57	70	124	65,5	11,0
																								3 1/4	83	HLP13304	13.489	18.289	8.03	9.53	10.87	2.50	2.25	2.76	4.88	2.58	24.3	204	242	276	63,4	57	70	124	65,5	11,0
																								3 5/16	84	HLP13305	13.489	18.289	8.03	9.53	10.87	2.50	2.25	2.76	4.88	2.58	24.3	204	242	276	63,4	57	70	124	65,5	11,0
																								-	85	HLP13085M	13.489	18.289	8.03	9.53	10.87	2.50	2.25	2.76	4.88	2.58	24.3	204	242	276	63,4	57	70	124	65,5	11,0
																								3 3/8	86	HLP13306	13.489	18.289	8.03	9.53	10.87	2.50	2.25	2.76	4.88	2.58	24.3	204	242	276	63,4	57	70	124	65,5	11,0
																								3 7/16	-	HLP13307	13.489	18.289	8.03	9.53	10.87	2.50	2.25	2.36	4.88	2.76	24.3	204	242	276	63,4	57	60	124	70,0	11,0
																								3 1/2	89	HLP13308	13.489	18.289	8.03	9.53	10.87	2.50	2.25	2.36	4.88	2.76	24.3	204	242	276	63,4	57	60	124	70,0	11,0
																								-	90	HLP13090M	13.489	18.289	8.03	9.53	10.87	2.50	2.25	2.36	4.88	2.76	26.5	204	242	276	63,4	57	60	124	70,0	12,0
																								3 9/16	91	HLP13309	13.489	18.289	8.03	9.53	10.87	2.50	2.25	1.34	4.33	2.91	26.5	204	242	276	63,4	57	34	110	74,0	12,0
																								3 5/8	92	HLP13310	13.489	18.289	8.03	9.53	10.87	2.50	2.25	1.34	4.33	2.91	26.5	204	242	276	63,4	57	34	110	74,0	12,0
																								3 1 1/16	94	HLP13311	13.489	18.289	8.03	9.53	10.87	2.50	2.25	1.34	4.33	2.91	26.5	204	242	276	63,4	57	34	110	74,0	12,0
																								3 3/4	95	HLP13312	13.489	18.289	8.03	9.53	10.87	2.50	2.25	1.34	4.33	2.91	26.5	204	242	276	63,4	57	34	110	74,0	12,0
																								3 13/16	97	HLP13313	13.489	18.289	8.03	9.53	10.87	2.50	2.25	1.73	4.69	2.95	26.5	204	242	276	63,4	57	44	119	75,0	12,0
																								3 7/8	99	HLP13314	13.489	18.289	8.03	9.53	10.87	2.50	2.25	1.73	4.69	2.95	26.5	204	242	276	63,4	57	44	119	75,0	12,0
																								3 15/16	100	HLP13315	13.489	18.289	8.03	9.53	10.87	2.50	2.25	1.73	4.69	2.95	26.5	204	242	276	63,4	57	44	119	75,0	12,0
																								4	102	HLP13400	13.489																			

▼ HMT drive unit with HSQ square drive cassette



Modular, Durable, Fast and Efficient Torque for Low-Profile and Square Drive Applications

Safety and Performance

- Innovative design that completely encloses all moving parts and minimizes pinch points
- Supplied reaction arm as standard
- Fully adjustable 360 degree in-line reaction arm
- Fine tooth ratchet prevents locking-on.

Simplicity

- Simple robust design with just three moving parts for reduced maintenance
- Push button, quick release, reversible square drive.

Versatility

- The reaction arm, positioned around the square drive instead of the back of the drive unit, provides you with the possibility to turn the drive unit away from an obstacle.

Accuracy

- Constant torque output provides accuracy of $\pm 3\%$ across full stroke.



Ergonomic Tool Handle

Robust ergonomic positioning handle comes standard with every HMT-Drive Unit.

Compatible HMT-Series drive units	Ergonomic Handle (Standard)
HMT1500, 3500, 7500	SWH6A
HMT13000	SWH10A



Back-Up Spanner

To be used to stop the back nut from turning during make up or break out. Two hexagon sizes in one tool.

Page: 225



Torque Wrench Hoses

Use Enerpac THQ-Series hoses with HMT-Series torque wrenches to ensure the integrity of your hydraulic system. See page 257.

2 m long, 2 hoses	THQ702T
6 m long, 2 hoses	THQ706T
12 m long, 2 hoses	THQ712T

HSQ, Square Drive Hydraulic Torque Wrenches



Bolting Integrity Software

Visit enerpac.com to access our free on-line bolting software application. A comprehensive free online software solution for Bolted Joint Integrity.

Integral databases hold data for:

- BS1560, MSS SP44, API 6A and 17D flanged joints
- Common gasket materials and configurations
- Comprehensive range of bolt materials
- Comprehensive range of lubricants

- Enerpac's Controlled Bolting Equipment including: Torque Multipliers, Hydraulic Wrenches and Bolt Tensioning tools.

Custom Joint information can also be entered

The software offers Tool selection, Bolt Load calculations and Tool pressure settings, as well as a combined Application data sheet and Joint completion report.

Page: 422

HSQ Series



Maximum Torque at 10.000 psi:

1541 - 7562 Ft.lbs

Maximum Torque at 690 bar:

2089 - 10.252 Nm

Square Drive Range:

3/4 - 1 1/2 inch

Maximum Operating Pressure:

690 bar / 10.000 psi

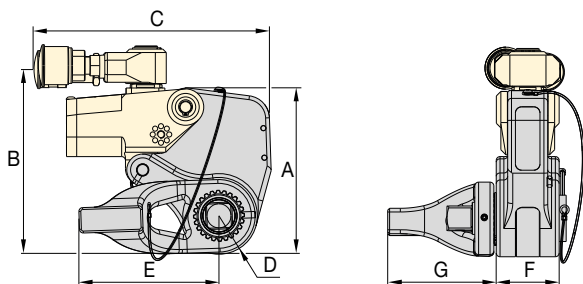
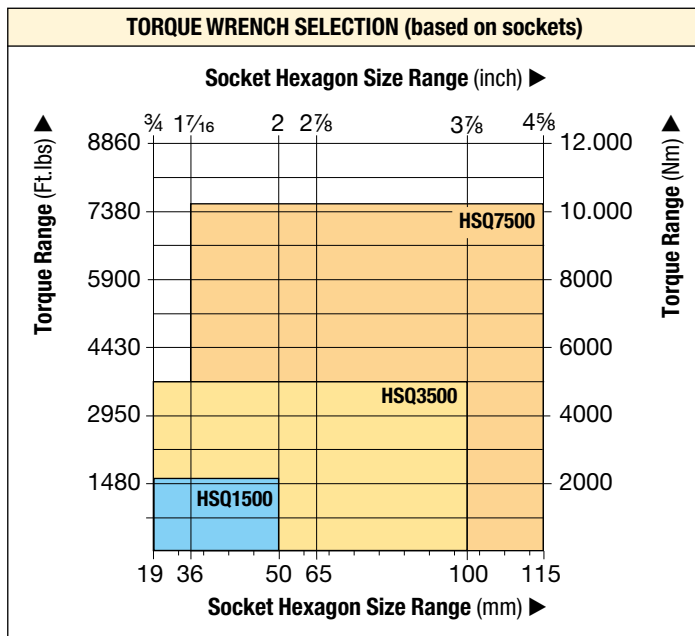

SELECTION CHART

Maximum Torque Output		Square Drive Size (inch)	Square Drive Cassette * Model Number	Dimensions (inch)							Weight (lbs)	Dimensions (mm)							Weight (kg)
(Ft.lbs)	(Nm)			A	B	C	D	E	F	G		A	B	C	D	E	F	G	
1541	2089	3/4	HSQ1500	5.71	6.61	6.85	1.19	2.36	1.95	3.29	8.16	145	168	174	30	60	50	84	3,7
3750	5084	1	HSQ3500	7.54	8.23	7.95	1.52	3.07	2.58	4.35	13.01	192	209	202	39	78	66	111	5,9
7562	10.252	1 1/2	HSQ7500	9.60	10.08	9.25	1.99	4.33	3.23	6.32	25.13	244	256	235	51	110	82	161	11,4

* **IMPORTANT:** HMT-drive units must be ordered separately to operate the HSQ-Square Drive Cassettes.



BSH-Series Sockets

Heavy-Duty Impact Sockets for power driven torquing equipment.

Page: 224



Select the Right Torque

Choose your Enerpac Torque Wrench using the untightening rule of thumb: Loosening torque equals about 250% of tightening torque.



Torque Pumps

Visit enerpac.com for system matched air and electric torque wrench pumps that are ideal for use with hydraulic torque wrenches.

Page: 273

▼ Shown from left to right: E291, E393, E494



- High-efficiency planetary gear sets achieve high output torque from low input torque
- Operator protected by anti-backlash device
- Torque multiplier accuracy $\pm 5\%$
- Reversible, tighten or loosen bolts
- Reaction bar or reaction plate style
- Angle-of-turn protractor standard on E300-Series models
- Reaction plate models offer increased versatility with reaction point locations
- E300 and E400-Series have replaceable shear drives, providing overload protection of internal power train
- One replacement shear drive is included with each E300 and E400-Series models.



◀ Enerpac Reaction Bar Torque Multiplier E393 used to manually torque bolts up to 4300 Nm.

Accurate, Efficient Torque Multiplication

When accurate make-up or break-out of stubborn fasteners requires high torque



Typical Torque Multiplier Applications

- Locomotives
- Power plants
- Pulp and paper mills
- Refineries
- Chemical plants
- Mining and construction
- Off-road equipment
- Shipyards
- Cranes.



Back-Up Spanners

To be used to stop the back nut from turning during make up or break out. Two hexagon sizes in one tool.

Page: 225

▼ SELECTION CHART

Torque Multiplier Type	Nominal Torque Output		Model Number
	(Nm)	(Ft.lbs)	
Reaction Bar Multiplier	1020	750	E290PLUS
	1358	1000	E291
	1627	1200	E391
	2983	2200	E392
	4340	3200	E393
Reaction Plate Multiplier	2983	2200	E492
	4339	3200	E493
	6779	5000	E494
	10.846	8000	E495



Manual Torque Multipliers

Enerpac manual torque multipliers provide efficient torque multiplication in wide clearance applications and when external power sources are not available.

Manual torque multipliers are used in most industrial, construction, and equipment maintenance applications. Hydraulic torque wrenches are better suited for tight tolerance, flange and repetitive bolting applications.

Use Reaction Bar Models:

- Where space is limited,
- Where multiple reaction points are available,
- when portability is desirable.

Use Reaction Plate Models:

- Above 4300 Nm output torque,
- On flanges and applications where neighbouring bolt or nut is available to react against
- When extreme reaction forces are generated.

E Series



Nominal Torque Output:

1020 - 10.846 Nm

Torque Ratio:

3:1 - 52:1

Output Ratio Accuracy:

± 5 %



CAUTION!

Never use impact air tools for power driving torque multipliers. Torque multiplier drive train damage will occur.

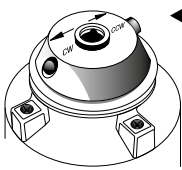

Selector Pawl

Models with anti-backlash protection have directional selector pawls. Set the pawl for clockwise or counter-clockwise rotation.

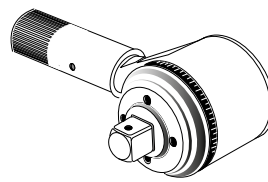

Angle-of-Turn Protractor

E391, E392 and E393 models include an angle-of-turn protractor (scale) to tighten fasteners using a "torque turn" method. Allows accurate measuring a specific number of degrees of rotation.

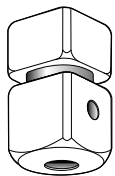

Shearable Square Drive

Provides overload protection on E300- and E400-series multiplier's power train by shearing when the rated capacity of the tool is exceeded. Internal shear pin prevents tool from falling off bolt.

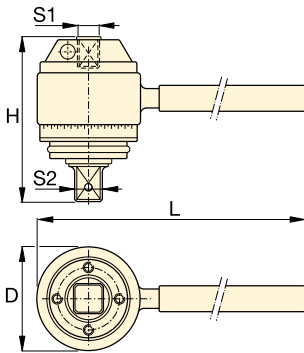

Reaction Bar Type ¹⁾

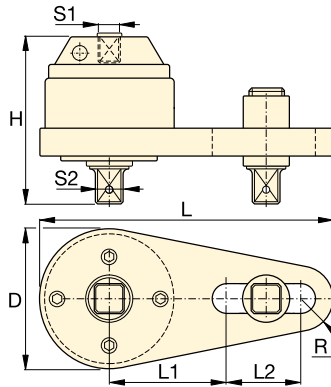

Reaction Plate Type ¹⁾



Hydraulic Torque Wrenches

Enerpac offers a complete range of square drive and hexagon cassette torque wrenches.

Page: 219



BSH-Series Sockets

Heavy-Duty Impact Sockets for power driven torquing equipment.

Page: 224

Input Torque ²⁾	Torque Ratio	Input Female Square Drive	Output Male Square Drive		Over-load protection	Anti-Backlash	Dimensions (mm)						Model Number	
			S2 (inch)	Replaceable Shear Drive Model Nr.			D	H	L	L1	L2	R		
339 (Nm) / 250 (Ft.lbs)	3,3 : 1	1/2 (inch)	3/4 (inch)	–	No	No	71	83	217	–	–	–	1,8 (kg)	E290PLUS
452 (Nm) / 333 (Ft.lbs)	3,3 : 1	1/2 (inch)	3/4 (inch)	–	No	No	71	83	443	–	–	–	2,5 (kg)	E291
271 (Nm) / 200 (Ft.lbs)	6 : 1	1/2 (inch)	3/4 (inch)	E391SDK	Yes	No	100	102	497	–	–	–	4,1 (kg)	E391
220 (Nm) / 162 (Ft.lbs)	13,6 : 1	1/2 (inch)	1 (inch)	E392SDK	Yes	Yes	103	146	497	–	–	–	6,9 (kg)	E392
235 (Nm) / 173 (Ft.lbs)	18,5 : 1	1/2 (inch)	1 (inch)	E393SDK	Yes	Yes	103	165	497	–	–	–	8,3 (kg)	E393
219 (Nm) / 162 (Ft.lbs)	13,6 : 1	1/2 (inch)	1 (inch)	E392SDK	Yes	Yes	124	140	356	140	124	32	7,8 (kg)	E492
234 (Nm) / 173 (Ft.lbs)	18,5 : 1	1/2 (inch)	1 (inch)	E393SDK	Yes	Yes	124	163	356	140	124	32	8,9 (kg)	E493
256 (Nm) / 189 (Ft.lbs)	26,5 : 1	1/2 (inch)	1 1/2 (inch)	E494SDK	Yes	Yes	143	222	378	178	89	42	15,4 (kg)	E494
209 (Nm) / 154 (Ft.lbs)	52 : 1	1/2 (inch)	1 1/2 (inch)	E495SDK	Yes	Yes	148	273	387	178	89	48	22,8 (kg)	E495

¹⁾ E200 and E400-series do not have an Angle-of-Turn Protractor (scale).

²⁾ User must verify manual torque wrench accuracy prior to use to ensure accurate final output torque.

▼ PTW1000



Productivity

- High speed continuous rotation for constant torque output
- Low friction planetary gearbox design minimizes wear and extends uptime.

Safety

- Ergonomic, low vibration design reduces fatigue and the risk of vibration related injuries for the operator
- Low noise air motor provides quiet, consistent performance for indoor and outdoor applications.

Convenience

- Provided with standard reaction arm; wide assortment of custom arms and accessories are available
- Available with or without Filter-Regulator-Lubricator (FRL)
- Unique calibration certificate provided with each tool.



◀ The PTW1000 makes quick work of this flange maintenance job.

Continuous Rotation Controlled Torque



Calibration Certificate

All PTW-Series tools are CE declared and are shipped complete with a calibration certificate.



FRL120C, Filter-Regulator-Lubricator with air hose

All PTW-Series tools are shipped complete with standard reaction arm, and Filter-Regulator-Lubricator (FRL120C).



MCS-Series, Mobile Calibration System

To check torque accuracy, run calibration tests and create calibration certificates prior to the use of continuous rotation torque tools in various applications while on a job site.

Page: 272

▼ PTW-Series Pneumatic Torque Wrenches are ideal for applications where speed and precision are critical, such as track maintenance.



Pneumatic Torque Wrenches



PTW-Series, Pneumatic Torque Wrenches

Enerpac PTW-Series Pneumatic Torque Wrenches are designed for applications that require speed and control.

The standard package includes a Torque Wrench with a calibration certificate, an FRL (Filter/Regulator/Lubricator), and a 3 m long, ½" inch (13 mm) diameter air hose, which connects the FRL to the wrench.

Once the air hoses are connected, the operator simply adjusts the air pressure on

the FRL to achieve the desired torque using the calibration certificate. After this, the tool is ready to go to work! *

The air source used with the PTW system must be regulated and/or limited to 8,3 bar, and must be capable of providing a volume of at least (85 m³/h) at 6,9 bar. A separate ½" inch hose (not included) must be used to connect the FRL to the air supply.

* See instruction manual for comprehensive instructions.

PTW Series



Nominal Torque Output:

8135 Nm

Square Drive Range:

¾ - 1 - 1½ inch

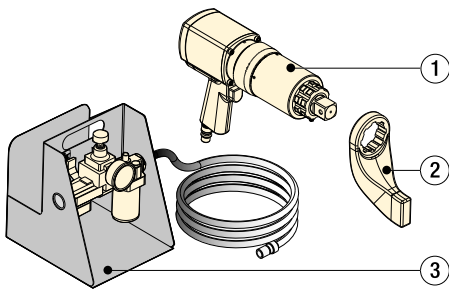

- ① PTW Torque Wrench
- ② Standard Reaction Arm
- ③ FRL120C Filter-Regulator-Lubricator with 3 meters air hose

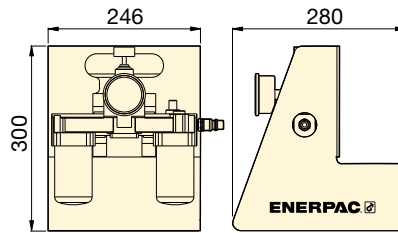
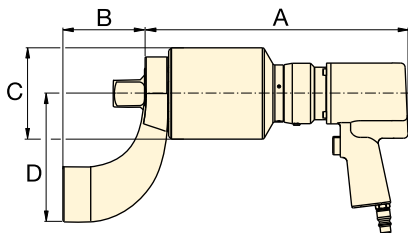

Accessories

Enerpac offers a full line of accessories including a range of reaction arms and drives.

Page: 268



BSH-Series Sockets

Heavy-Duty Impact Sockets for power driven torquing equipment.

Page: 224



Back-Up Spanners

Hands-free tool to be used to stop back nut from turning during make up or break out.

Page: 225

▼ SELECTION CHART

All tools are shipped complete with standard reaction arm and FRL120C.

Minimum Torque		Nominal Torque		Square Drive (inch)	Model Number ¹⁾ (FRL120C included)	Speed (RPM)	Dimensions (mm)				Weight (kg) ²⁾
(Nm)	(Ft.lbs)	(Nm)	(Ft.lbs)				A	B	C	D	
407	300	1356	1000	¾	PTW1000-75C	12,6	272	83	72	130	7,9
407	300	1356	1000	1	PTW1000C	12,6	272	83	72	130	8,2
678	500	2712	2000	1	PTW2000C	8,0	286	83	79	133	8,8
1220	900	4067	3000	1	PTW3000C	3,1	343	83	95	133	10,4
1763	1300	8135	6000	1½	PTW6000C	2,5	366	114	127	178	17,7

¹⁾ To order without FRL120C, remove "C" suffix from model number (example: **PTW3000**).

²⁾ Weight does not include reaction arm. Reaction arm weight for PTW1000, PTW2000, PTW3000 is 1,3 kg and for PTW6000 is 3,5 kg.

Accessories for PTW-Series Torque Wrenches **ENERPAC**

▼ Shown: Accessories for PTW-Series Torque Wrenches



- Accessories for further extending the application range of pneumatic torque wrenches
- Extended drives increases tool fit in restricted access areas.



PTW-Accessories

Enerpac offers the following accessories to support a wide variety of applications in industries such as mining, power generation and oil & gas. For additional custom accessories not pictured here, please contact Enerpac.



Applications

PTW-Series Pneumatic Wrenches are designed for applications that require speed and control.

Mining

- Track maintenance
- Undercarriage maintenance
- Wheel maintenance
- Shovel maintenance

Power Generation

- Turbine bolts
- Tower segments
- Turbine casings

Oil & Gas

- Pipe flanges
- Valves
- Manway covers
- Pressure vessels

▼ PTW-Wrenches are ideal for applications where speed and precision are critical, such as track or wheel maintenance.



Accessories for PTW-Series Torque Wrenches

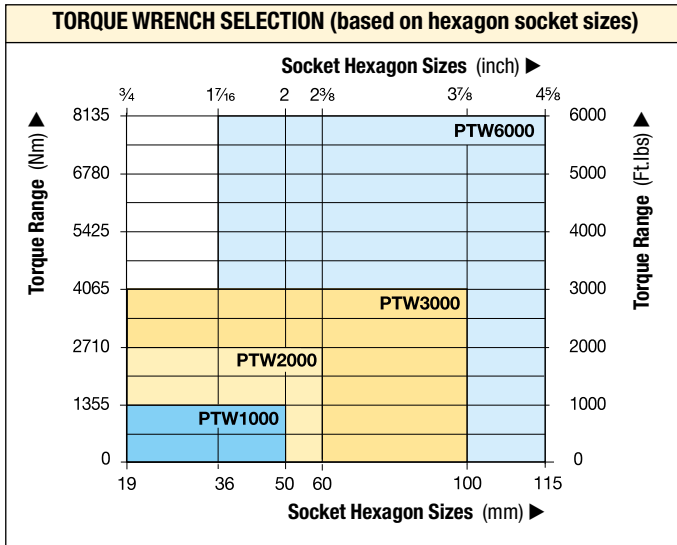

PTW Series



Nominal Torque Output:

8135 Nm

Square Drive Range:

3/4 - 1 - 1 1/2 inch

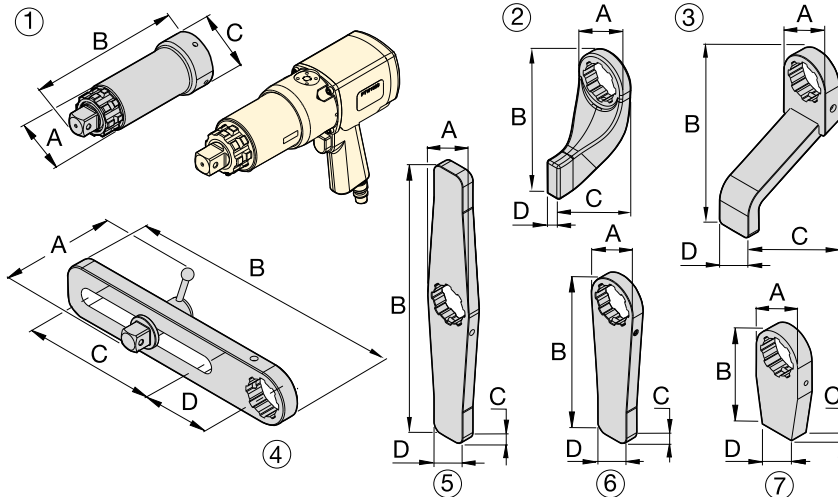

BSH-Series Sockets

Use Heavy-Duty Impact Sockets for power driven torquing equipment.

Page: 224



BUS-Series, Back-Up Spanners

Hands-free tool to be used to stop back nut from turning during make up or break out.

Page: 225

Optional Accessories

For use with PTW1000, 2000, 3000-models

Nr.	Description	Model Nr.	Application	Dimensions (mm)			
				A	B	C	D
1	Extended Drive, 6 inch (152 mm)	ED6TWS	Nose extension, primarily for truck wheel bolts	62	206	73	-
1	Extended Drive, 12 inch (305 mm)	ED12TWS	Nose extension, primarily for truck wheel bolts	62	384	73	-
1	Extended Drive, 18 inch (457 mm)	ED18TWS	Nose extension, primarily for truck wheel bolts	62	511	73	-
2	Standard Reaction Arm	RATWS	Standard arm included with PTW model	76	172	102	21
3	Extended Reaction Arm	ERATWS	Long plate for use with deep well sockets	73	150	202	51
4	Sliding Reaction Arm	SLRATWS	For widely spaced and uneven bolt centers	112	381	203	102
5	Double Straight Reaction Arm	DSATWS	Reduces time to reposition arm *	73	406	19	102
6	Straight Reaction Arm	SRATWS	Long plate for wide spaced reaction points	73	240	19	51
7	Blank Reaction Arm **	BLTWS	Weldable blank for custom applications **	72	151	25	51

For use with PTW6000-models

1	Extended Drive 6 inch (152 mm)	ED6TWL	Nose extension, primarily for truck wheel bolts	84	232	102	-
1	Extended Drive 12 inch (305 mm)	ED12TWL	Nose extension, primarily for truck wheel bolts	84	384	102	-
2	Standard Reaction Arm	RATWL	Standard arm included with PTW model	102	229	146	32
3	Extended Reaction Arm	ERATWL	Long plate for use with deep well sockets	102	254	184	64
4	Sliding Reaction Arm	SLRATWL	For widely spaced and uneven bolt centers	152	419	190	114
5	Double Straight Arm	DSATWL	Reduces time to reposition arm *	102	508	32	57
6	Straight Reaction Arm	SRATWL	Long plate for wide spaced reaction points	102	305	32	57
7	Blank Reaction Arm **	BLTWL	Weldable blank for custom applications **	102	152	32	57

* Time to reposition arm when repeatedly moving from tightening to loosening.

** WARNING: Blank reaction arms must be heat treated to HRc 38-42 prior to use.

▼ STTC2000 Safe T™ Torque Checker



Quick, simple and accurate mobile torque system safety testing device



Applications

All bolted joints from 144 Ft.lbs up to 16.100 Ft.lbs (195 - 21.800 Nm).

- All Enerpac torque wrenches up to the maximum capacity of the Torque Checker. Also for other brands that fit the envelope of the Torque Checker.
- Oil & Gas flanges,
- Tower Crane installation,
- Bigger machine installation/assembly,
- Wind Tower installation etc.

Industries:

- Oil & Gas, Petrochemical,
- Wind Power Generation,
- Marine,
- Manufacturing,
- Mining, Rail and more.

Safety & Accuracy

- Durable mobile testing device for Enerpac hydraulic torque wrench systems
- Delivering ultimate on site accuracy, testing the entire wrench, pump and hose system to be used on the job
- Consistent and repeatable $\pm 1\%$ accurate range.

Durability

- Durable splash-proof keypad and display for those harsh working environments
- Impact-resistant composite carry case.

Simplicity

- Allows the user to validate & test the exact system (torque wrench, pump, hose, etc.) to give a digital read out in Ft.lbs or Nm
- Easy to operate: power up and start testing
- Transportable: all in one compact carry case, ideal for use on the road with its durable internal 3,6 V-2,2 Ah Lithium-ion battery.

Versatility

- Can test all Enerpac S, W, RSL, HMT and DSX-Series wrenches of both square drive and hexagon cassettes up to 16.100 Ft.lbs (21.800 Nm)
- Hexagon Reducers or Square Drive Sockets to be bought separately.

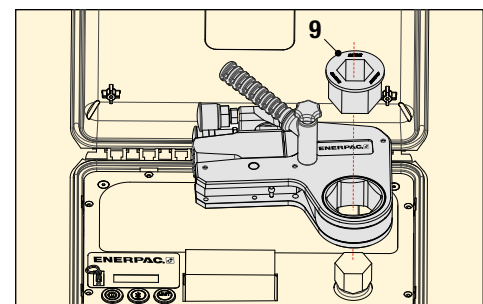
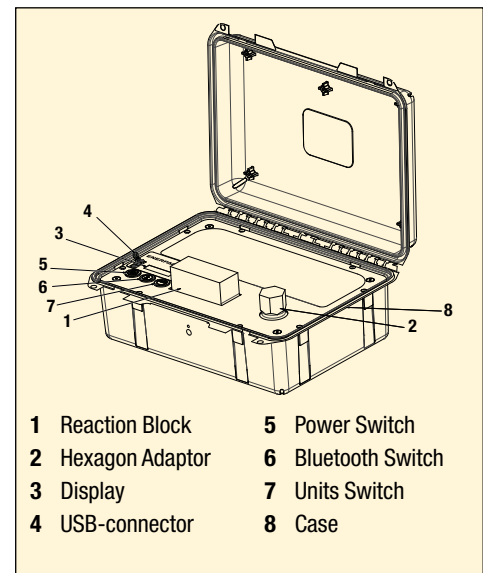

Hexagon Reducer (nr. 9) must be bought separately: see selection tables on next page. ▶

Safe T™ Torque Checker



Safe T™ Torque Checker

Mobile, compact safety device allows the end user to instantly validate the performance of the entire system to be used - not just the wrench only. Allows the user to test the system on-site and in situ.

The user can validate and test the exact torque system (wrench, pump, hose, etc) to give an accurate digital read out.

Safety

The user can verify if the torque system is safe to operate, functioning correctly and within the desired safety parameters.

Unique from Enerpac

No need to wait for annual calibration tests to be confident in the performance and safety of your equipment. The Safe T™ Torque Checker equipment can be validated in seconds, saving time and money.

Hexagon Reducers

The W-Series Hexagon Reducers from the tables below, can be used with all W, RLP and HLP-Series hexagon cassettes.

STTC Series



Max. Testing Output:

16.100 Ft.lbs (21.800 Nm)

Accuracy:

± 1%

Battery:

3,6 V-2,2 Ah Lithium-ion

For use with STTC2000		
Hexagon Size	Cassette Model Number	Hexagon Reducer to 1 3/16" (30 mm) Model Nr.
(inch)	(mm)	
1 1/16	-	W2101X -
1 1/8	-	W2102X -
1 3/16	30	W2103X *
1 1/4	32	W2104X **
1 1/2	-	W2105X **
1 5/8	-	W2106X W2106R103D
1 7/8	36	W2107X W2107R103D
1 1/2	38	W2108X W2108R103
1 9/16	-	W2109X W2109R103
1 5/8	41	W2110X W2110R103
1 11/16	-	W2111X W2111R103
1 3/4	-	W2112X W2112R103
1 13/16	46	W2113X W2113R103
1 7/8	-	W2114X W2114R103
1 15/16	-	W2115X W2115R103
2	50	W2200X W2200R103
2 1/16	-	W2201X W2201R103
2 1/8	-	W2202X W2202R103
2 1/4	55	W2203X W2203R103
2 1/2	-	W2204X W2204R103
2 5/8	-	W2205X W2205R103
2 3/4	60	W2206X W2206R103

For use with STTC4000		
Hexagon Size	Cassette Model Number	Hexagon Reducer to 1 3/16" (36 mm) Model Nr.
(inch)	(mm)	
1 5/16	-	W4105X -
1 3/8	-	W4106X -
1 7/16	36	W4107X *
1 1/2	-	W4108X **
1 9/16	-	W4109X **
1 5/8	41	W4110X W4110R107
1 11/16	-	W4111X W4111R107
1 3/4	-	W4112X W4112R107
1 13/16	46	W4113X W4113R107
1 7/8	-	W4114X W4114R107
1 15/16	-	W4115X W4115R107
2	50	W4200X W4200R107
2 1/16	-	W4201X W4201R107
2 1/8	-	W4202X W4202R107
2 1/4	55	W4203X W4203R107
2 1/2	-	W4204X W4204R107
2 5/8	-	W4205X W4205R107
2 3/4	60	W4206X W4206R107
2 7/8	-	W4207X W4207R107
2 15/16	-	W4208X W4208R107
2 3/4	70	W4212X W4212R107
2 13/16	-	W4213X W4213R107
2 7/8	-	W4214X W4214R107
2 15/16	75	W4215X W4215R107
3	-	W4300X W4300R107
3 1/16	-	W4301X W4301R107
3 1/8	80	W4302X W4302R107
3 1/4	-	W4303X W4303R107
3 1/2	-	W4304X W4304R107
3 5/8	-	W4305X W4305R107
3 3/4	-	W4306X W4306R107
-	85	W4085MX W4085MR107

For use with STTC8000		
Hexagon Size	Cassette Model Number	Hexagon Reducer to 2 inch (50 mm) Model Nr.
(inch)	(mm)	
1 7/8	-	W8114X -
1 15/16	-	W8115X -
2	50	W8200X *
2 1/16	-	W8201X **
2 1/8	-	W8202X **
2 1/4	55	W8203X W8203R200
2 1/2	-	W8204X W8204R200
2 5/8	-	W8205X W8205R200
2 3/4	60	W8206X W8206R200D
2 7/8	-	W8207X W8207R200
2 15/16	-	W8208X W8208R200
2 3/4	65	W8209X W8209R200
2 5/8	-	W8210X W8210R200
2 11/16	-	W8211X W8211R200
2 3/4	70	W8212X W8212R200
2 13/16	-	W8213X W8213R200
2 7/8	-	W8214X W8214R200
2 15/16	75	W8215X W8215R200
3	-	W8300X W8300R200
3 1/16	-	W8301X W8301R200
3 1/8	80	W8302X W8302R200
3 1/4	-	W8303X W8303R200
3 1/2	-	W8304X W8304R200
3 5/8	-	W8305X W8305R200
-	85	W8085MX W8085MR200
3 3/8	-	W8306X W8306R200
3 1/2	-	W8307X W8307R200
3 3/4	-	W8308X W8308R200
-	90	W8090MX W8090MR200
3 5/8	-	W8309X W8309R200
3 3/4	-	W8310X W8310R200
3 11/16	-	W8311X W8311R200
3 3/4	95	W8312X W8312R200
3 13/16	-	W8313X W8313R200
3 3/8	-	W8314X W8314R200
3 15/16	100	W8315X W8315R200
4	-	W8400X W8400R200
4 1/16	-	W8401X W8401R200
4 1/8	105	W8402X W8402R200

For use with STTC15000		
Hexagon Size	Cassette Model Number	Hexagon Reducer to 2 5/8 inch Model Nr.
(inch)	(mm)	
2 7/16	-	W15207X -
2 1/2	-	W15208X -
2 9/16	65	W15209X -
2 5/8	-	W15210X *
2 11/16	-	W15211X **
2 3/4	70	W15212X **
2 13/16	-	W15213X **
2 7/8	-	W15214X W15214R210
2 15/16	75	W15215X W15215R210
3	-	W15300X W15300R210
3 1/16	-	W15301X W15301R210
3 1/8	80	W15302X W15302R210
3 1/4	-	W15303X W15303R210
3 1/2	-	W15304X W15304R210
3 5/8	-	W15305X W15305R210
-	85	W15085MX W15085MR210
3 3/8	-	W15306X W15306R210
3 1/2	-	W15307X W15307R210
3 3/4	-	W15308X W15308R210
-	90	W15090MX W15090MR210
3 5/8	-	W15309X W15309R210
3 3/4	-	W15310X W15310R210
3 11/16	-	W15311X W15311R210
3 3/4	95	W15312X W15312R210
3 13/16	-	W15313X W15313R210
3 3/8	-	W15314X W15314R210
3 15/16	100	W15315X W15315R210
4	-	W15400X W15400R210
4 1/16	-	W15401X W15401R210
4 1/8	105	W15402X W15402R210
4 1/4	-	W15403X W15403R210
4 1/2	-	W15404X W15404R210
4 5/8	110	W15405X W15405R210
4 3/8	-	W15406X W15406R210
4 7/16	-	W15407X W15407R210
4 1/2	-	W15408X W15408R210
-	115	W15115MX W15115MR210
4 3/8	-	W15409X W15409R210
4 5/8	-	W15410X W15410R210



Hexagon Reducers:

Must be bought separately. Can be used with all W, RLP and HLP-Series

hexagon cassettes.

* Standard hexagon size of adaptor included with STTC-model

** Requires special reaction block.

Nominal Measurable Torque Output		Model Number ¹⁾	Hexagon Adaptor included		Carry Case Size L x B x H	Sockets to be used with Square Drive Wrenches ²⁾	Hexagon Cassette fits Adaptor. For other hexagon sizes, see table above with Hexagon Reducers sizes ²⁾			
(Ft.lbs)	(Nm)		(inch)	(mm)	(mm)		(kg)	W-Series	RSL-Series	HMT-Series
2140	2900	STTC2000	1 3/16	30	414 x 328 x 328	6	BSH7530	W2103X	RLP1103	HLP1103
4383	5950	STTC4000	1 7/16	36	414 x 328 x 328	8	BSH1036	W4107X	RLP3107	HLP3107
8893	12.000	STTC8000	2	50	624 x 498 x 168	19	BSH1550	W8200X	RLP5200	HLP3200
16.100	21.800	STTC15000	2 5/8	-	624 x 498 x 168	26	BSH15263	W15210X	RLP8210	HLP7210

¹⁾ With 3,6 V-2,2 Ah Lithium-ion battery.

²⁾ Square drive sockets, hexagon cassettes and hexagon reducers must be bought separately.

▼ MCS7500C, Mobile Calibration System



MCS Series

Measurable Output Torque Range:
200 - 10.000 Nm

Measurable Output Torque Range:
148 - 7378 Ft.lbs

Female Square Drive:
1½ inch



Accuracy

The calibration system is a calibrated instrument qualified in a UKAS certified laboratory. The accuracy of the MCS7500C is calibrated to meet or exceed: 1% of FSD from 2% to 8% of torque range and 1% of reading from 8% to 100% of torque range.

Versatility

- Accurately measures torque output for continuous rotation tools and square drive hydraulic (*) torque wrenches from 200 - 10.000 Nm (148 - 7375 Ft.lbs)
- Adaptable design enables use with a large variety of Enerpac and competitive wrenches
- Internal Li-ion battery pack, external power via 5V DC USB power supply.

Performance

- Certificate Manager feature enables quick and easy creation of calibration certificates
- Tool database feature allows specific wrench data and calibration results to be recorded and saved for future use
- Each MCS comes with a standard ISO17025 calibration certificate.

Ease of Use

- Compact design in carrying facilitates easy transport, allowing calibration to be carried out in the shop, on jobsites, or even in a vehicle
- Integrated digital interface enables torque values to be displayed, saved, printed or transferred to a computer.



Female Reducer Set

The Female Reducer Set consists of two reducers: 1½ x 1 inch and 1½ x ¾ inch. To be ordered separately as **MCS7500RS**.



Additional Reaction Block and Adaptor

A heavy-duty adjustable reaction block in combination with one of the three adaptors is required to facilitate the use with S, RSQ and DSX-Series Square Drive Wrenches as well as most competitive hydraulic wrenches to maximum 10.000 Nm (7375 Ft.lbs). Drawings of additional reaction block and adaptor are available upon request.

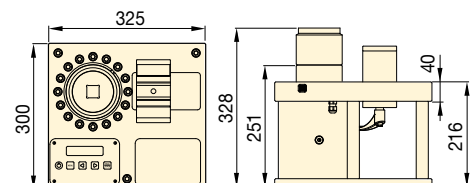





























Minimum Measurable Torque Output		Nominal Measurable Torque Output		Female Square Drive	Model Number **	Description	(kg)
(Nm)	(Ft.lbs)	(Nm)	(Ft.lbs)				
200	148	10.000	7375	1½	MCS7500C	MCS with carrying case	40

* Additional Reaction Block and appropriate Adaptor is required with the use of S, RSQ and DSX-Series square drive hydraulic wrenches.

** Not suitable for use with impact tools or low profile torque wrenches.

Optimum Wrench-Torque Pump Combinations

For optimum speed and performance Enerpac recommends the following system set-up with wrench-pump-hose combinations. For other combinations, consult your Enerpac bolting expert or your authorized Enerpac distributor.

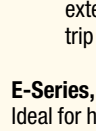
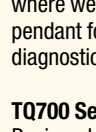
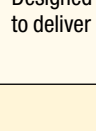
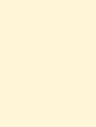
		ELECTRIC TORQUE PUMPS					AIR DRIVEN TORQUE PUMPS	
		Cordless XC-Series	E-Pulse® E-Series	TQ-Series	ZU4T-Series	ZE4T-Series ZE5T-Series	LAT-Series	ZA4T-Series
								
		Page: 274	Page: 276	Page: 278	Page: 280	Page: 284	Page: 286	Page: 288
Speed:								
Oil Flow at 700 bar:	0,25 l/min	0,52 l/min	0,5 l/min	1,0 l/min	0,8 - 1,6 l/min	0,4 l/min	1,0 l/min	
Reservoir Capacity:	2,0 litres	3,0 litres	4,0 litres	4,6 - 6,8 litres	4,6 - 39 litres	3,0 litres	4,6 - 6,8 litres	
Duty Cycle:	Intermittent	Heavy-Duty	Standard	Heavy-Duty	Heavy-Duty	Standard	Heavy-Duty	
Weight:								
Work:	Field	Field/Factory	Field/Factory	Field	Factory	Field	Field	
 220	S1500PX	Optimal	Optimal	Optimal	Optimal	Optimal	Optimal	
	S3000PX							
 228	S6000PX	-	Acceptable	Acceptable	Optimal	Optimal	Optimal	
	S11000PX							
 242	S25000PX	Optimal	Optimal	Optimal	Optimal	Optimal	Optimal	
	W2000PX							
 254	W4000PX	-	Acceptable	Acceptable	Optimal	Optimal	Optimal	
	W8000PX							
 258	W15000PX	Optimal	Optimal	Optimal	Optimal	Optimal	Optimal	
	W22000PX							
 274	W35000PX	-	Acceptable	Acceptable	Optimal	Optimal	Optimal	
	RSL1500							
 280	RSL3000	Optimal	Optimal	Optimal	Optimal	Optimal	Optimal	
	RSL5000							
 286	RSL8000	-	Acceptable	Acceptable	Optimal	Optimal	Optimal	
	RSL11000							
 292	RSL19000	Optimal	Optimal	Optimal	Optimal	Optimal	Optimal	
	RSL28000							
 300	DSX1500	Optimal	Optimal	Optimal	Optimal	Optimal	Optimal	
	DSX3000							
306	DSX5000	-	Acceptable	Acceptable	Optimal	Optimal	Optimal	
	DSX11000							
312	DSX25000	Optimal	Optimal	Optimal	Optimal	Optimal	Optimal	
	HMT1500							
318	HMT3500	Acceptable	Acceptable	Acceptable	Optimal	Optimal	Optimal	
	HMT7500							
324	HMT13000	-	Acceptable	Acceptable	Optimal	Optimal	Optimal	



XC-Series, Portable Cordless Pumps
Ideal for bolting applications at sites that do not have access to power or where having extension cords or air hoses could cause trip hazards.

E-Series, E-Pulse Portable Torque Pumps
Ideal for high volume fastening applications where weight is critical. Feature an interactive pendant for operation, programming and diagnostics.

TQ700 Series Electric Torque Pumps
Designed for both portability and production, to deliver superior bolting speed.

ZU4T-Series, Electric Torque Pumps
Works well with long extension cords or generator driven electrical power supplies. Available in **Pro** and **Classic** formats.
ZU4T Pro Pumps have an LCD feature to display torque or pressure, selectable torque wrench, and self-diagnostics.
ZU4T Classic Pumps feature an analogue gauge and a basic electrical package to deliver durable, safe and efficient hydraulic power.

ZE-T Series Electric Torque Pumps
Features LCD to display torque or pressure values, and self-diagnostics. With induction motor, making the ZE-Series the coolest and quietest pumps in their class.

LAT-Series, Lightweight Torque Air Pumps
Combines compact design and high productivity for bolting applications in areas hard to access with larger air powered pumps.

ZA4T-Series Air Driven Torque Pumps
This air driven pump is best suited to power medium to large size torque wrenches.

THQ-Series, Torque Wrench Hoses
Use Enerpac THQ-Series twin hoses with all torque wrenches to ensure the integrity of your hydraulic system (see page 257).

▼ XC1502TE



- Ideal for maintenance bolting applications requiring portability and convenience
- Interactive pendant provides visual and vibration feedback of pump operation
- Superior run-time with 5Ah, 28V battery
- 6 metres detachable pendant control
- 100 mm glycerine-filled gauge for easy viewing
- Bladder reservoir allows pump to be used in any position
- High-strength fiberglass reinforced composite housing provides superior durability in demanding job site environments
- Integrated handle and carrying strap for portability.

Portable Battery Pump for Torque Applications



28-Volt Battery

The **XC28V5** 5 Amps battery with Lithium-Ion technology for maximum battery performance.



Battery Charger

1-hour quick charger.

115V battery charger

XC115VC

230V battery charger

XC230VC



Roll Cage

Roll cage accessory option for both XC-TW and XC pump. Please order model number **XCRCTK**.



Torque Wrenches

The following torque wrenches are ideal for use with the XC-Series Cordless Torque Wrench Pumps:

S	W	RSL	DSX	HMT
S1500PX	W2000PX	RSL1500	DSX1500	HMT1500
S3000PX	W4000PX	RSL3000	DSX3000	HMT3500
		RSL5000		HMT7500

Larger torque wrenches will work with the cordless pump, battery run time and application speed will be impacted.

Page: **273**

- Glycerin-filled gauge
- Trigger lock-off
- Integrated carrying handle
- Impact-resistant composite housing
- 28V, 5 Amps/hr lithium-ion battery
- Brushless DC motor
- 2 liter oil reservoir
- Interactive pendant



XC-Series, Cordless Torque Wrench Pumps



Battery-Powered Torque Wrench Pumps

The XC-Series Cordless Torque Wrench pump is ideal for applications in the PowerGen, Oil & Gas and MRO markets. This portable pump is perfect for remote locations, sites that do not have access to power or where trip hazards are a concern.

The interactive pendant allows the user to set and clear pressure and operate in manual or auto-cycle mode. The pump has an easily accessible user adjustable valve for precise pressure control.

Torque Wrench Model	Nut A/F (mm)	Stud (mm)	Pressure (bar)	Torque (Nm)	Fasteners torqued
S3000X	60	38	330	2035	32
W2000X	60	38	350	1356	52

XC Series



Reservoir Capacity:
2,0 litres

Flow at Rated Pressure:
0,25 l/min

Motor Size:
0,37 kW

Maximum Operating Pressure:
700 bar

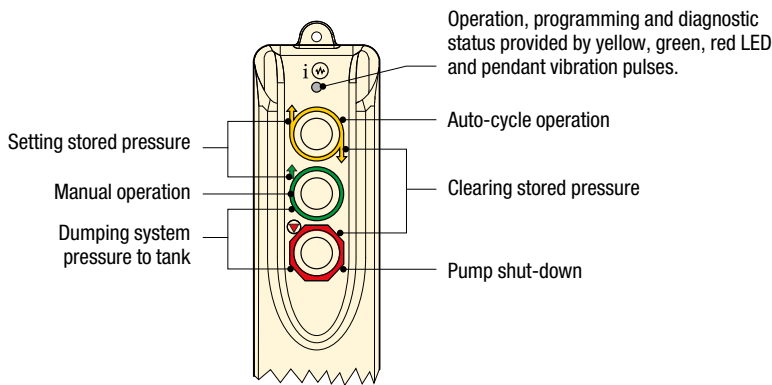

Torque Wrench Hoses

Use Enerpac 700 bar THQ-Series torque wrench hoses with torque wrenches and pumps. See page 257.

2 m long, 2 hoses	THQ702T
6 m long, 2 hoses	THQ706T
12 m long, 2 hoses	THQ712T

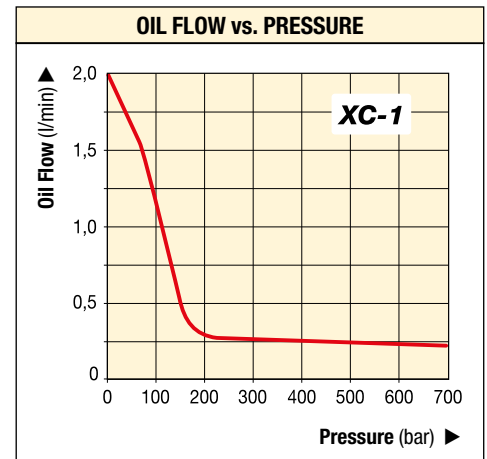
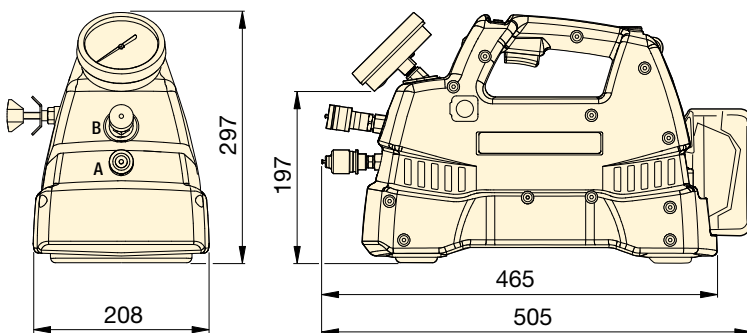

SELECTION CHART

Description	Useable Oil Capacity (litres)	Model Number	Output Flow Rate (l/min)			Included with pump	Weight (kg) ¹⁾
			No Load	140 bar	700 bar		
Cordless Pump Kit	2,0	XC1502TB	2,05	0,49	0,25	2 batteries and 115V charger	12
Cordless Pump Kit	2,0	XC1502TE	2,05	0,49	0,25	2 batteries and 230V charger	12
Cordless Pump	2,0	XC1502T	2,05	0,49	0,25	No batteries or charger	12

¹⁾ Weight includes oil, without battery. Battery weight 1,1 kg.

▼ EP3504TE, E-Pulse Torque Wrench Pump



Performance

- Two-stage pump with high by-pass pressure: 1,0 l/min at 200 bar, 0,52 l/min at 700 bar
- Smart controls enable motor to maintain constant power across the pressure range
- 24VDC power regulator minimizes effects of poor power supply
- Six-piston block design provides even flow for smooth operation.

Durability

- Durable aluminium housing
- Integrated heat exchanger minimizes heat buildup
- High-efficiency permanent magnet, direct drive motor enables continuous use and long service life
- Built-in thermal protection
- IP Rating: IP54 on the pump, IP67 on the pendant.

Convenience

- Integrated calibrated pressure gauge
- Interactive pendant with smart controls
- Pendant and cord management system
- Intelligent Auto-Cycle enables press and release actuation to cycle torque wrench until final torque is achieved
- User can set pressure and operate in manual or auto-cycle mode
- Convenient oil fill port, oil level indicator and automatic breather.

Productivity through innovation



Bolting Integrity Software

A comprehensive on-line software solutions for Bolted Joint Integrity. The software offers Tool selection, Bolt Load calculations and Tool pressure settings, as well as, a combined Application Data Sheet and Joint Completion Report. Custom Joint information can also be entered.

Page: 422



Torque Wrenches

The following torque wrenches are ideal for use with the E-Pulse Torque Wrench Pumps:

S	W	RSL	DSX	HMT
S1500PX	W2000PX	RSL1500	DSX1500	HMT1500
S3000PX	W4000PX	RSL3000	DSX3000	HMT3500
		RSL5000	DSX5000	HMT7500

Larger torque wrenches will work with the pump, but application speed will be impacted.

Page: 273



Torque Wrench Hoses

Use Enerpac 700 bar THQ-Series torque wrench hoses with torque wrenches and pumps. See page 257.

2 m long, 2 hoses	THQ702T
6 m long, 2 hoses	THQ706T
12 m long, 2 hoses	THQ712T

E-Pulse®, Electric Torque Wrench Pumps



E-Pulse Torque Wrench Pumps

The Enerpac E-Pulse Electric Torque Wrench Pump, through its innovative design, is ideal for high volume fastening applications where weight is a critical factor. Smart controls enable the motor to maintain constant power providing higher flow than traditional pumps.

The durable aluminum housing, integrated heat exchanger and highly efficient permanent magnet motor minimize heat buildup in the toughest environments. The interactive pendant provides the operator a number of usage options for optimal efficiency. The E-Pulse Torque Wrench Pump is the pinnacle of bolting equipment.

E Series



Reservoir Capacity:
3,0 litres

Flow at Rated Pressure:
0,52 l/min

Motor Size:
0,63 kW

Maximum Operating Pressure:
700 bar

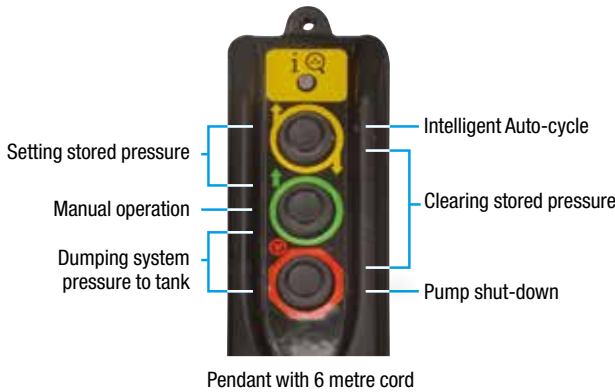

Pendant with 6 metre cord

Interactive Torque Wrench Pendant

- User can set pressure and operate in manual or auto-cycle mode
- Intelligent Auto-Cycle enables press and release actuation to cycle torque wrench until final torque is achieved.

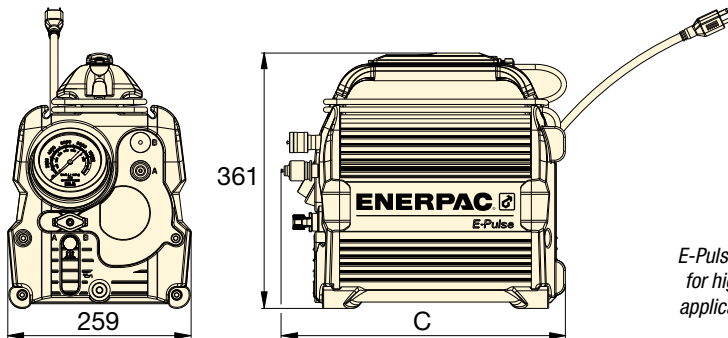
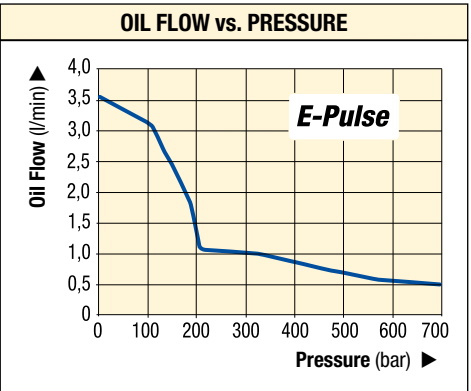

E-Pulse torque pump used for high volume fastening applications where weight is a critical factor. ▶



▼ SELECTION CHART

Number of Wrenches pump can operate	Useable Oil Capacity (litres)	Model Number	Output Flow Rate (l/min)				Motor Voltage (VAC)	Current Draw (Amps)	Plug Type	Sound Level (dBA)	Dimension C (mm)	Weight (kg) ¹⁾
			1 bar	175 bar	350 bar	700 bar						
1	3,0	EP3504TB	3,61	2,13	0,95	0,52	100-120	12	NEMA 5-15	70-85	401	20,4
		EP3504TI	3,61	2,13	0,95	0,52	200-250	7	NEMA 6-15	70-85	401	20,4
		EP3504TE	3,61	2,13	0,95	0,52	200-250	7	Schuko CEE 7/7	70-85	401	20,4
2	3,0	EP3504TB-M *	3,61	2,13	0,95	0,52	100-120	12	NEMA 5-15	70-85	429	21,7
		EP3504TI-M *	3,61	2,13	0,95	0,52	200-250	7	NEMA 6-15	70-85	429	21,7
		EP3504TE-M *	3,61	2,13	0,95	0,52	200-250	7	Schuko CEE 7/7	70-85	429	21,7

* Pump model with multi-port manifold.

¹⁾ with oil

▼ TQ700E



- Optimized flow technology – three stage pump maximizes productivity of the pump and tool while minimizing heat build-up and down time
- Heat exchanger is standard included
- A quiet (<85 dBA), lightweight pump with a compact footprint – easy to move around and through the work site
- Durable roll cage with an ergonomically sized handle and shielded gauge – a pump that is easy to put into position and safe from on site operational hazards
- Maintenance made simple with a brushless motor designed for continuous usage
- Straightforward operation with a simple pressure set and convenient to use 6 m pendant control – immediate productivity for crews operating the pump
- IP55 Rating for Superior Dust and Water Protection
- Transparent gauge overlays in Nm and Ft.lbs for all Enerpac torque wrenches provide a quick torque reference.



The TQ700E and the W-Series wrenches are a productive combination in wind applications.

Lightweight Torque Wrench Pumps



Four Port Manifold

The TQ700 offers an optional four wrench manifold as an accessory factory installed. (Add suffix "M" at the end of the model number.

For example: **TQ700EM**).



Torque Wrench Hoses

Use Enerpac 700 bar THQ-Series torque wrench hoses with torque wrenches and pumps.

See page 257.

2 m long, 2 hoses

THQ702T

6 m long, 2 hoses

THQ706T

12 m long, 2 hoses

THQ712T



Hydraulic Torque Wrenches

Enerpac offers a complete range of square drive and hexagon cassette torque wrenches.

Page: 219



Overlay Kit with Gauge

Available separately for use with TQ-Series: **GT4015Q** includes gauge and torque overlays for all Enerpac torque wrenches.



TQ700 Applications

The TQ-Series pumps are ideal for powering hydraulic wrenches for the Power Generation and Wind Markets.

Bolting speed is more complex than how much flow per minute the pump produces. The key is optimising the flow rate across the entire bolting cycle. With more oil flowing at the right time and at the right volume, you achieve the optimized flow for a hydraulic bolting system.

The result of this optimized flow is more bolts tightened faster and a more productive work team.

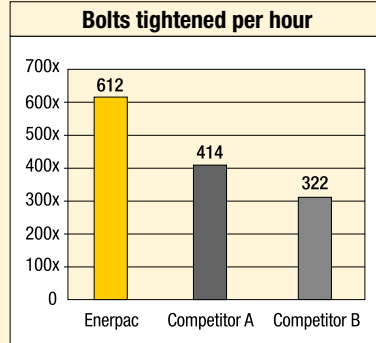

Internal laboratory testing based on standard torquing procedure on a pipe flange with 14, 1 1/2" bolts.

TQ Series



Reservoir Capacity:
4,0 litres

Flow at Rated Pressure:
0,5 l/min

Motor Size:
0,75 kW

Maximum Operating Pressure:
700 bar



Torque Pump Selection Matrix

For optimum speed and performance see the torque pump and hose selection matrix.

Page: **273**

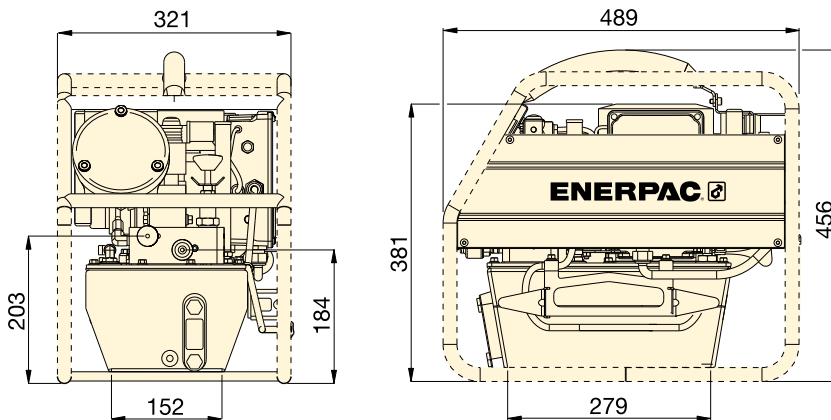

For Use with Torque Wrenches	Pressure Rating (bar)	Model Number ¹⁾	Useable Oil Capacity (litres)	Motor Size (kW)	Motor Electrical Specifications (Volt - Ph - Hz)	Sound Level (dBA)	Weight (kg)
All Series	700	TQ700B	4,0	0,75	115 - 1 - 50/60	82 - 85	31
	700	TQ700E ²⁾	4,0	0,75	230 - 1 - 50	82 - 85	30
	700	TQ700I ³⁾	4,0	0,75	230 - 1 - 60	82 - 85	30

¹⁾ All models meet CE safety requirements and all TÜV requirements.

²⁾ TQ700E with European plug and CE EMC directive compliant.

³⁾ TQ700I with NEMA 6-15 plug.

▼ The TQ700E and the W-Series wrenches are a productive combination.



▼ ZU4204TE-Q (Pro), ZU4204BE-Q (Classic)



Z Tough, Dependable Innovative CLASS



Classic Electrical

Basic electrical package includes mechanical contactor, ON/OFF toggle switch, pendant with electro-mechanical push buttons, 24V transformer timer and operator accessible circuit breaker.

- Features Z-Class high-efficiency pump design; higher oil flow and bypass pressure, cooler running and requires 18% less current draw than comparable pumps
- Powerful 1,25 kW universal electric motor provides high power-to-weight ratio and excellent low-voltage operating characteristics
- High-strength, molded composite shroud protects motor and electrical components, while providing an ergonomic, non-conductive handle for easy transport
- Low-voltage pendant provides additional safety for the operator.

Pro Series pump only

- LCD readout provides pressure display and a number of diagnostic and readout capabilities never before offered on a portable electric pump
- AutoCycle feature provides continuous cycle operation of the torque wrench as long as the advance button is pressed (pump can be used with or without auto cycle feature).



Pro-Series

Back-lit LCD and Pressure Transducer featuring Auto-Cycle Technology.

- Torque wrench model is selectable
- "Auto cycle" setting easily programmable.
- Digital read-out and "Autocycle" setting
- Pump usage information, hour and cycle counts
- Low-voltage warning and recording
- Self-test and diagnostic capabilities
- Information can be displayed in English, French, German, Italian, Spanish and Portuguese
- Pressure transducer is more accurate and durable than analog gauges
- Easy-viewing variable rate display
- Display pressure in bar, MPa or psi.



◀ Any brand of hydraulic torque wrench can be powered by the portable ZU4T-Series torque pump.

ZU4T-Series, Torque Pumps



Z-Class – A Pump For Every Application

Patented Z-Class pump technology provides high bypass pressures for increased productivity – important in applications using long hose runs and high pressure-drop circuits, like heavy lifting or certain double-acting tools.

Enerpac ZU4T-Series pumps are built to power small to large torque wrenches. Choosing the right ZU4T-Series torque wrench pump for your application is easy.

Classic Electric Torque Wrench Pump

- The Classic has traditional electro-mechanical components (transformers, relays and switches) in place of solid-state electronics. The Classic delivers durable, safe and efficient hydraulic power.

Pro Series Electric Torque Wrench Pump

- Digital (LCD) display features a built-in hour meter, pressure display and shows self-diagnostic, cycle-count and low voltage warning information. These premium features are not available on any other pump – anywhere!
- Auto-Cycle feature provides continuous cycle operation of the torque wrench as long as the advance button is pressed (pump can be used with or without Auto-Cycle feature).

ZU4T-Series, Torque Pump
Ordering Guide

Page: 283

ZU4T Series



Reservoir Capacity:

4,6 - 6,8 litres

Flow at Rated Pressure:

1,0 l/min

Motor Size:

1,25 kW

Maximum Operating Pressure:

700 bar



Bolting Integrity Software

Enerpac Bolting Integrity Software Solutions play a key role in implementing and managing an Integrity Program for bolted connections.

The software offers Tool selection, Bolt Load calculations and Tool pressure settings, as well as, a combined Application Data Sheet and Joint Completion Report.

Custom Joint information can also be entered.

Page: 422

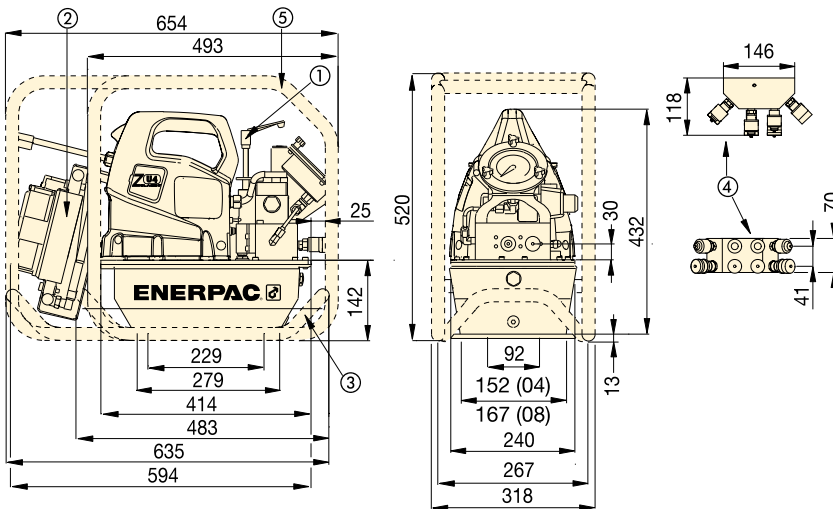

- ① User adjustable relief valve
- ② Heat Exchanger (optional)
- ③ Skidbar (optional)
- ④ 4-wrench manifold (optional)
- ⑤ Roll cage (optional)

ZU4T-Series Torque Pumps

ZU4T-Series Performance Chart									
Motor Size (kW)	Output Flow Rate (l/min)				Motor Electrical Specification (Volt - Phase - Hz)	Sound Level (dBA)	Relief Valve Adjustment Range (bar)		
	7 bar	50 bar	350 bar	700 bar					
1,25	11,5	8,8	1,2	1,0	115 - 1 - 50/60 208-240 - 1 - 50/60	85-90	124-700		



Overlay Kit with Gauge

Available separately for use with ZU4T-Series Classic: **GT4015Q** includes gauge and torque overlays for all Enerpac torque wrenches.

OIL FLOW VERSUS PRESSURE

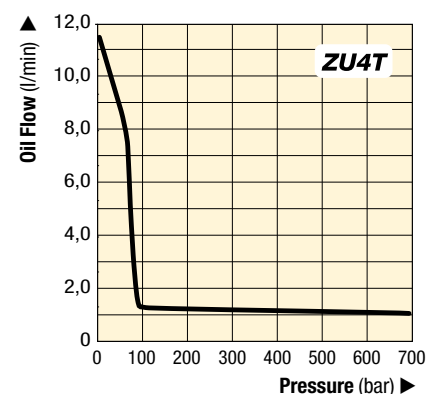



4-Wrench Manifold

- For simultaneous operation of multiple torque wrenches.

Accessory Kit * Model Nr.	Can be used on ZU4T-Series torque pumps
ZTM-Q *	for 700 bar torque wrenches

* 4-Wrench Manifold adds 2,7 kg to pump weight.



Skid Bar

- Provides greater pump stability on soft or uneven surfaces
- Provides easy two-handed lift.

Accessory Kit Model Nr.	Can be used on ZU4T-Series torque pumps
SBZ-4	4,6 and 6,8 litres reservoir ¹⁾
SBZ-4L	4,6 and 6,8 litres reservoir ²⁾

¹⁾ Without heat exchanger 2,2 kg.

²⁾ With heat exchanger 3,2 kg.



Heat Exchanger

- Removes heat from the bypass oil to provide cooler operation
- Stabilizes oil viscosity, increasing oil life and reduces wear of pump and other hydraulic components.

Accessory Kit * Model Nr.	Can be used on ZU4T-Series torque pumps
ZHE-U115	115 V pumps
ZHE-U230	230 V pumps

* Heat Exchanger adds 4,1 kg to pump weight.



Roll Cage

- Protects pump
- Provides greater pump stability.

Thermal Transfer *	Max. Pressure	Max. Oil Flow	Voltage
(Btu/h)	(bar)	(l/min)	(VDC)
900	20,7	26,5	12

* At 1,9 l/min at 21 °C ambient temperature. Do not exceed maximum oil flow and pressure ratings. Heat exchanger is not suitable for water-glycol or high water-based fluids.

▼ These rigid steel wrenches with low profile interchangeable hexagon cassettes guarantee durability and maximum versatility in bolting applications.



Accessory Kit Model Nr.	Can be used on ZU4T-Series torque pumps
ZRC-04	4,6 and 6,8 litres reservoir ¹⁾
ZRC-04H	4,6 and 6,8 litres reservoir ²⁾

¹⁾ Without heat exchanger 4,3 kg.

²⁾ With heat exchanger 4,3 kg.



Torque Wrench Hoses

Use Enerpac THQ-Series twin safety hoses to connect your torque wrench to the pump. See page 257.

For 700 bar	Model Nr.
2 m long, 2 hoses	THQ702T
6 m long, 2 hoses	THQ706T
12 m long, 2 hoses	THQ712T

ZU4T-Series, Torque Pump Ordering Guide

▼ Select a pump from the model matrix at the bottom of the page.

The functionality of the pump can be determined by the model number. Utilize the guide below to select the best pump for the application.

Z	U	4	2	08	T	E	-	Q	H	M
1 Product Type	2 Motor Type	3 Flow Group	4 Valve Type	5 Reservoir Size	6 Valve Operation	7 Voltage	8 Must be Q	8 Factory Installed Accessories		

1 Product Type

Z = Pump series

2 Motor Type

U = Universal electric motor

3 Flow Group

4 = 1,0 l/min @ 700 bar

4 Valve Type

2 = Torque wrench valve

5 Reservoir Size

04 = 4,6 litres

08 = 6,8 litres

6 Valve Operation

T = **Pro Series pump** with solenoid valve and pendant, LCD Electric and pressure transducer

B = **Classic pump** with solenoid valve and pendant.

7 Voltage

B = 115V, 1 ph, 50/60 Hz

E = 208-240V, 1 ph, 50/60 Hz (with European plug CE RF compliant)

I = 208-240V, 1 ph, 50/60 Hz (with NEMA 6-15 plug)

8 Factory installed accessories

H = Heat exchanger

K = Skid bar

M = 4-wrench manifold

R = Roll cage

ZU4T Series



Reservoir Capacity:

4,6 - 6,8 litres

Flow at Rated Pressure:

1,0 l/min

Motor Size:

1,25 kW

Maximum Operating Pressure:

700 bar





Torque Pump Selection Matrix

For optimum speed and performance see the torque pump and hose selection matrix.

Page: 273

▼ ZU4T-SERIES CLASSIC TORQUE PUMP MODELS

ZU4T Classic ¹⁾ Model Numbers 230 VAC, 1 ph ²⁾	Reservoir Capacity (litres)	Factory Installed Accessories					 (kg)
		Heat Exchanger	Roll Cage	Skid Bar	4-Wrench Manifold		
ZU4204BE-Q (B, I)	4,6						33
ZU4208BE-Q (B, I)	6,8						35
ZU4204BE-QH (B, I)	4,6	●					40
ZU4208BE-QH (B, I)	6,8	●					39
ZU4204BE-QR (B)	4,6		●				37
ZU4208BE-QR (B)	6,8		●				39
ZU4204BE-QHR (B)	4,6	●	●				41
ZU4208BE-QHR (B, I)	6,8	●	●				44
ZU4208BE-QHK (B, I)	6,8	●		●			42
ZU4208BE-QHM (B, I)	6,8	●			●		42
ZU4208BE-QMR (B)	6,8		●		●		42
ZU4208BE-QHMR (B, I)	6,8	●	●		●		46

¹⁾ Classic Electric Pump has traditional electro-mechanical components (transformers, relays, switches) in place of solid-state electronics.



²⁾ "B" indicates pump is 115V, 1-phase, 50/60 Hz. Model number example: **ZU4204BB-QHR**.

"I" indicates pump is 208-240V, 1-phase, 50/60 Hz with NEMA 6-15 plug. Model number example: **ZU4208BI-QHR**.

³⁾ "B" indicates pump is 115V, 1-phase, 50/60 Hz. Model number example: **ZU4204TB-QHR**.

"I" indicates pump is 208-240V, 1-phase, 50/60 Hz with NEMA 6-15 plug. Model number example: **ZU4204TI-QHR**.

▼ ZU4T-SERIES PRO TORQUE PUMP MODELS

ZU4T Pro Model Numbers 230 VAC, 1 ph ³⁾	Reservoir Capacity (litres)	Factory Installed Accessories					 (kg)
		Heat Exchanger	Roll Cage	Skid Bar	4-Wrench Manifold		
ZU4204TE-Q (B, I)	4,6						31
ZU4208TE-Q (B, I)	6,8						34
ZU4204TE-QH (B, I)	4,6	●					35
ZU4208TE-QH (B, I)	6,8	●					38
ZU4204TE-QR (B)	4,6		●				35
ZU4208TE-QR (B)	6,8		●				38
ZU4204TE-QHR (B)	4,6	●	●				40
ZU4208TE-QHR (B, I)	6,8	●	●				42
ZU4208TE-QHK (B, I)	6,8	●		●			41
ZU4208TE-QHM (B, I)	6,8	●			●		41
ZU4208TE-QMR (B)	6,8		●		●		41
ZU4208TE-QHMR (B, I)	6,8	●	●		●		45

▼ ZE4204TE-QHR



- **Auto-Cycle feature provides continuous cycle operation of the torque wrench as long as the advance button is pressed (pump can be used with or without auto cycle feature)**
- **LCD readout provides pressure and torque display and a number of diagnostic and readout capabilities never before offered on a portable electric pump**
- **Totally enclosed, fan-cooled industrial electric motors supply extended life and stand up to harsh industrial environments**
- **High-strength, molded electrical enclosure protects electronics, power supplies and LCD readout from harsh environments.**

Z

**Tough,
Dependable
Innovative
CLASS**



Pro-Series

Back-lit LCD and Pressure Transducer featuring Auto-Cycle Technology.

- Torque wrench model is selectable
- "Auto cycle" setting easily programmable.
- Digital read-out and "Autocycle" setting
- Pump usage information, hour and cycle counts
- Low-voltage warning and recording
- Self-test and diagnostic capabilities
- Information can be displayed in English, French, German, Italian, Spanish and Portuguese
- Pressure transducer is more accurate and durable than analog gauges
- Easy-viewing variable rate display
- Display pressure in bar, MPa or psi.



◀ *The ZE4T-Series torque wrench pumps are perfectly matched for this W2000X wrench.*



Bolting Integrity Software

Enerpac Bolting Integrity Software Solutions play a key role in

implementing and managing an Integrity Program for bolted connections.

The software offers Tool selection, Bolt Load calculations and Tool pressure settings, as well as, a combined Application Data Sheet and Joint Completion Report.

Custom Joint information can also be entered.

ZE4T AND ZE5T-SERIES OIL FLOW VERSUS PRESSURE

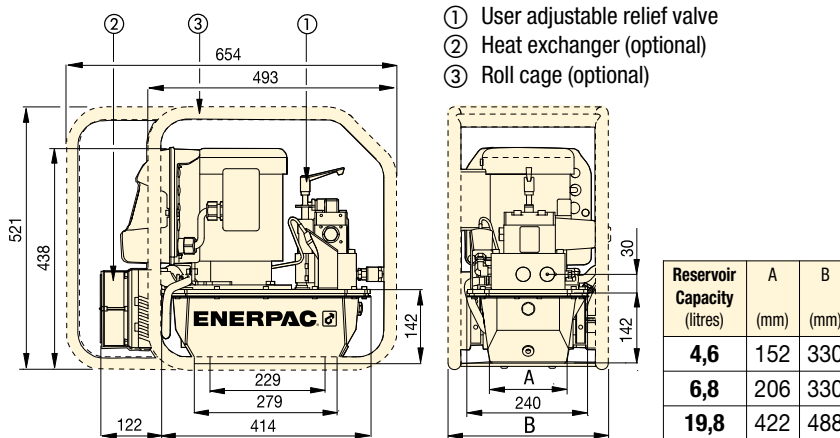
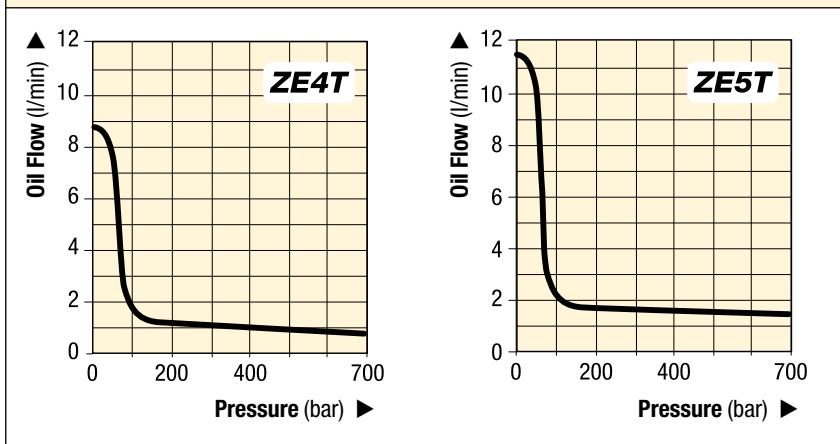

ZE4T and ZE5T-Series

▼ PERFORMANCE CHART

Pump Series	Output Flow Rate at 50 Hz (l/min)				Motor Size (kW)	Relief Valve Adjustment Range (bar)	Sound Level (dBA)
	7 bar	50 bar	350 bar	700 bar			
ZE4T	8,8	8,1	0,9	0,8	1,1	70 - 700	75
ZE5T	11,8	11,2	1,7	1,6	2,2	70 - 700	75

For Use With Wrenches	Model Number ¹⁾	Reservoir Capacity (litres)	Factory Installed Accessories			Weight (kg)
			Heat Exchanger	Roll Cage	4-Wrench Manifold	
All Series	ZE4204TE-QR (B)	4,6		●		54
	ZE4204TE-QHR (B)	4,6	●	●		59
	ZE4208TE-QHR (B)	6,8	●	●		61
	ZE4208TE-QHMR (B)	6,8	●	●	●	64
All Series	ZE5204TW-QHR (G, J)	4,6	●	●		64
	ZE5208TW-QHR (G, J)	6,8	●	●		67
	ZE5208TW-QHMR (G, J)	6,8	●	●	●	70
	ZE5220TW-QHR (G, J)	19,8	●	●		88

¹⁾ "B" suffix model numbers shown are 115 VAC, 1-phase, 50/60 Hz. Model number order example: **ZE4204TB-QR**.
 "E" indicates pump available in 208-240 VAC, 1 phase, 50/60 Hz with European plug and CE EMC compliant.
 "J" indicates pump available in 460-480 VAC, 3-phase, 50/60 Hz. Model number order example: **ZE5208TJ-QHR**.
 "G" indicates pump available in 208-240 VAC, 3-phase, 50/60 Hz. Model number order example: **ZE5208TG-QHR**.
 "W" indicates pump available in 380-415 VAC, 3-phase, 50/60 Hz. Model number order example: **ZE5208TW-QHR**.

ZE4T ZE5T Series



Reservoir Capacity:

4,6 - 19,8 litres

Flow at Rated Pressure:

0,82 - 1,64 l/min

Motor Size:

1,1 - 2,2 kW

Maximum Operating Pressure:

700 bar



Torque Wrench Pump Selection Matrix

For optimum speed and performance see the torque wrench pump and hose selection matrix.

Page: 273



Accessories

Descriptions can be found in the ZU4T-Series pump section.

Page: 282



Torque Wrench Hoses

Use Enerpac 700 bar THQ-Series torque wrench hoses with torque wrenches and pumps.

2 m long, 2 hoses	THQ702T
6 m long, 2 hoses	THQ706T
12 m long, 2 hoses	THQ712T

▼ LA2504TX-QR, Air-Driven Hydraulic Torque Pump



Ex IIC T4 Gc
IIIC T135°C Dc

Improved Operator Efficiency and Ergonomics

- Easy to lift, transport and maneuver
- Hand carry where no crane, hoist or elevator is available
- One person transport up ladders and stairs
- Ideal for use on narrow or constrained scaffolding, catwalks, pipe racks and lifts.

High Productivity

- Proven 3 piston design provides leading fastening and breakout speed to stay on time and under budget
- ATEX certified to meet worksite compliance requirements.

Reduce Equipment Downtime

- Roll cage with reinforcement to support and protect FRL
- Rugged 1/2" NPTF air supply connection with integrated roll cage support
- Key components are easy to access and service.

Standard Features

- 4,5 m pendant cord for mobility around work site
- 100 mm calibrated gauge with certificate, scale in bar and psi
- Roll cage and Filter-Regulator-Lubricator (FRL).

Lightweight and Compact



Torque Pump Selection Matrix

For optimum speed and performance see the torque wrench and pump matrix.

Page: 273



Torque Wrench Hoses

Use Enerpac THQ-Series hoses with torque pumps to ensure the integrity of your hydraulic system.

For 700 bar	Model Nr.
2 m long, 2 hoses	THQ702T
6 m long, 2 hoses	THQ706T
12 m long, 2 hoses	THQ712T

Page: 257



ATEX Certified

The LAT-Series air-driven pumps are tested and certified according to the ATEX Directive 2014/34/EU.

The explosion protection is for Equipment Group II, Equipment Category 2 (Hazardous Area Zone 1), in Gas and/or Dust atmospheres.

Each LAT-Series air-driven pump contains the following markings:

Ex IIC T4 Gc and Ex IIIC T135°C Dc

Ex IIC T4 Gc
IIIC T135°C Dc



Air-Driven Hydraulic Torque Pump



LAT-Series Air-Driven Torque Pump

The Enerpac LAT Air-Driven Torque Pump combines compact design and high productivity for bolting applications in areas hard to access with larger air powered pumps.

Whether on an offshore platform, refinery or mine anywhere in the world, the pump is built for the toughest worksite environments.

Featuring a proven Enerpac piston design, reinforced FRL support and air supply connection, the LAT-pump will provide years of reliable service with fastening and breakout speeds to keep you on schedule and under budget.

LAT Series



Reservoir Capacity:

3,0 litres

Flow at Rated Pressure:

0,4 l/min

Maximum Operating Pressure:

700 bar

▼ Rugged 1/2" NPTF air supply connection with integrated roll cage support.



▼ Roll cage design supports and protects Filter-Regulator-Lubricator (FRL).

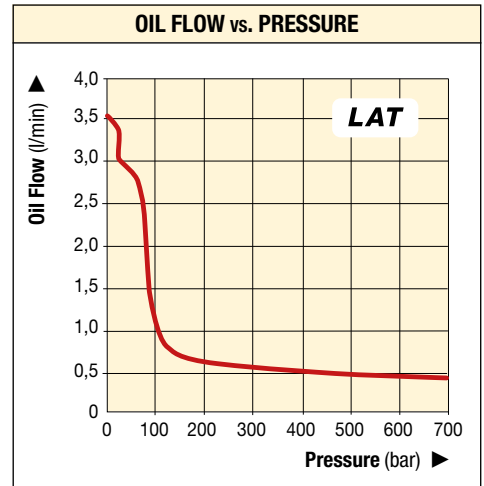

▼ Proven 3 piston design provides leading speed.



▼ Skid Rail accessory DD8365920K bolts to bottom of reservoir to prevent wear from rough surfaces.



▼ LAT-Series, the portable and compact torque pump.



Usable Oil Capacity (litres)	Model Number *	Output Flow Rate (l/min)			Valve Type	Air Pressure Range (bar)	Air Consumption (l/min)	Sound Level (dBA)	Dimensions (mm)			Weight (kg)
		No Load	350 bar	700 bar					Length	Width	Height	
1,9	LA2504TX-QR	3,5	0,6	0,4	4-way, 2-pos.	4,5 - 6,9	1389	87 - 90	435	250	375	18,0

* Enerpac Spin-On couplers are included. Pump hydraulic port thread size is 1/4"-18 NPTF.

▼ ZA4204TX-QR



Ex II 2 GD ck T4
DEKRA 0602

ZA4208TX-QRU105 Complete Set with Pump, Hose THQ706T and Roll Cage:

- Fine air pressure adjustment for very accurate torque control
- High bypass pressure (180 bar) for faster torque cycles
- Improved wrench performance at low pressure

Standard ZA4T-pump models:

- Two-speed operation and 100 bar by-pass pressure reduces cycle time for improved productivity
- Glycerin filled pressure gauge with transparent overlays in Nm and Ft.lbs for Enerpac torque wrenches provide a quick torque reference
- Standard Regulator-Filter-Lubricator with removable bowls and auto drain
- Heat exchanger warms exhaust air to prevent freezing and cools the oil
- Ergonomic pendant allows remote operation up to 6 m.



◀ Most hydraulic torque wrenches can be powered by the Enerpac ZA4T-Series torque pumps.

Z Tough, Dependable Innovative CLASS



Gauge with Overlay Kit

Gauge Overlay Kits are available separately for use with ZA4T-Series pumps:

GT4015Q includes gauge and overlays for all Enerpac all S, W, RSL, DSX and HMT-Series torque wrenches.



Torque Pump Selection Matrix

For optimum speed and performance see the torque pump selection matrix.

Page: 273



Torque Wrench Hoses

Use Enerpac THQ-Series hoses with torque pumps to ensure the integrity of your hydraulic system.

For 700 bar	Model Nr.
2 m long, 2 hoses	THQ702T
6 m long, 2 hoses	THQ706T
12 m long, 2 hoses	THQ712T

Page: 257



PowaPak™ Air Torque Pump

ZA4208TX-QR0P Pump with Stainless Steel Roll Cage and Certified Lifting Eye.

Page: 292

Air Driven Torque Pumps



ZA4T-Pump Applications

The ZA4T-Series pump is best suited to power medium to large size torque wrenches.

Patent-pending Z-Class technology provides high by-pass pressures for increased productivity.

Its high power to weight ratio and compact design make it ideal for applications which require easy transport of the pump.

All ZA4T-Series pump models meet CE, CSA and TÜV safety requirements. For further application assistance contact your local Enerpac office.

ATEX 95 Certified

The ZA4T-Series pumps are tested and certified according to the Equipment Directive 94 / 9 / EC "ATEX Directive".

The explosion protection is for Equipment Group II, Equipment Category 2 (Hazardous Area Zone 1), in Gas and/or Dust atmospheres. The ZA4T-Series pumps are marked with: **Ex II 2 GD ck T4**.



ZA4T Series



Reservoir Capacity:

4,6 - 6,8 litres

Flow at Rated Pressure:

1,0 l/min

Air Consumption:

600 - 2840 l/min

Maximum Operating Pressure:

700 bar

OIL FLOW VERSUS PRESSURE

6,9 bar dynamic air pressure at 2840 l/min

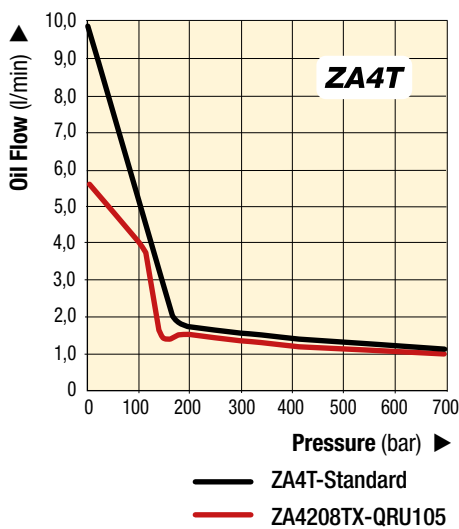

COMMON PUMP MODELS

For Use With Torque Wrenches	Maximum Operating Pressure (bar)	Model Number	Reservoir Capacity (litres)	Weight (kg)
all S, W, RSL, DSX and HMT-Series	700	ZA4208TX-QRU105 *	6,8	45
	700	ZA4204TX-Q	4,6	42
	700	ZA4208TX-Q	6,8	47
	700	ZA4204TX-QR **	4,6	46
	700	ZA4208TX-QR **	6,8	51

* Standard with roll cage, with THQ706T hose and fine air pressure adjustment for very accurate torque control. Pump weight 45 kg, complete set including hose weight 58 kg.

** With Roll Cage.



Accessory Options

Available by placing the following additional suffix at the end of the model number:

- K** = Skid bar
- M** = 4-wrench manifold
- R** = Roll cage.

Page: 290

▼ ZA4208TX-QRU105 for improved wrench performance and torque control at low pressure.





Skid Bar

- Provides greater pump stability on soft or uneven surfaces
- Provides easy two-handed lift.

Accessory Kit * Model Nr.	Can be used on ZA4T-Series torque pumps
SBZ-4	Reservoir 04 and 08

* Add suffix **K** for factory installation. Weight skid bar 2,2 kg.
Ordering Example: ZA4208TX-QK



4-Wrench Manifold

- For simultaneous operation of multiple torque wrenches
- Can be factory installed or ordered separately.

Accessory Kit * Model Nr.	Can be used on ZA4T-Series torque pumps
ZTM-Q	for 700 bar torque wrenches

* Add suffix **M** for factory installation. This option cannot be installed onto the ZA4208TX-QRU105 pump, as the valve manifold is different. Weight manifold 4,5 kg.
Ordering Example: ZA4208TX-QM



Roll Cage

- Protects pump
- Provides greater pump stability.

Accessory Kit * Model Nr.	Can be used on ZA4T-Series torque pumps
ZRC-04	Reservoir 04 and 08

* Add suffix **R** for factory installation. Roll cage weight 3,4 kg.
Ordering Example: ZA4208TX-QR



Torque Wrench Couplers

For Enerpac torque wrench couplers see our "System Components" section in this catalogue.

Page: 130



PowaPak™ Air Torque Pump

ZA4208TX-QR0P Pump with Stainless Steel Roll Cage and Certified Lifting Eye.

Page: 292



Torque Wrench Hoses

Use Enerpac twin safety hoses to connect your torque wrench to the pump. See page 257.

For 700 bar	Model Nr.
2 m long, 2 hoses	THQ702T
6 m long, 2 hoses	THQ706T
12 m long, 2 hoses	THQ712T

Ordering Matrix and Specifications

▼ This is how a ZA4T-Series pump model number is built up:

Z	A	4	2	08	T	X	-	Q	M	R
1 Product Type	2 Motor Type	3 Flow Group	4 Valve Type	5 Reservoir Size	6 Valve Operation	7 Voltage		8 Must be Q	8 Options	8 Options

1 Product Type

Z = Pump series

2 Motor Type

A = Air motor

3 Flow Group

4 = 1,0 l/min @ 700 bar

4 Valve Type

2 = Torque Wrench Valve

5 Reservoir Size

04 = 4,6 litres

08 = 6,8 litres

6 Valve Operation

T = Air operated valve with pendant

7 Voltage

X = Not applicable

8 Options

Q = 700 bar couplers for use with Enerpac or other torque wrenches

K = Skid bar

M = 4-wrench manifold

R = Roll cage

ZA4T Series



Reservoir Capacity:

4,6 - 6,8 litres

Flow at Rated Pressure:

1,0 l/min

Air Consumption:

600 - 2840 l/min

Maximum Operating Pressure:

700 bar

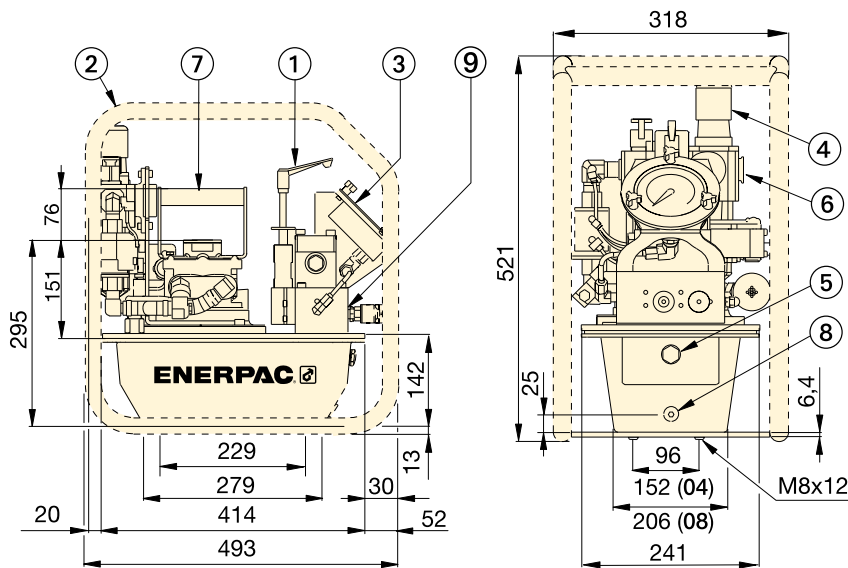

- ① User adjustable relief valve
- ② Roll Cage (optional)
- ③ Gauge with overlays
- ④ Filter/lubricator/regulator
- ⑤ Oil level sight gauge

- ⑥ Air input 1/2" NPTF
- ⑦ Standard handle
- ⑧ Oil drain
- ⑨ 1/4"-18 NPTF Oil outlet



How to order your ZA4T-Series torque pump

Model No. ZA4208TX-QMR

700 bar pump for use with Enerpac S-, W-, RSL, DSX and HMT-Series and other 700 bar torque wrenches, 6,8 litres reservoir, 4-wrench manifold, and roll cage.



Torque Pump Selection Matrix

For optimum speed and performance see the torque wrench and pump matrix.

Page: 273

ZA4T-Series Performance

Pump Model	Output Flow Rate (l/min)				By-pass pressure (bar)	Dynamic Air Pressure Range (bar)	Air Consumption (l/min)	Sound Level (dBA)	Relief Valve Adjustment Range (bar)
	7 bar	50 bar	350 bar	700 bar					
ZA4208TX-QRU105	5,7	4,5	1,4	1,0	180	7,0	600 - 2840	85-90	124 - 700
ZA4T Standard	9,8	8,2	1,4	1,0	100	4,0 - 6,9	600 - 2840	85-90	124 - 700

▼ ZA4208TX-QR0P



New ZA4T with Stainless Steel Roll Cage and Certified Lifting Eye



Torque Pump Selection Matrix

For optimum speed and performance see the torque wrench pump selection matrix.

Page: 273

- **Stainless-Steel Roll Cage** resists corrosion
- **Certified Lifting Eye** for transporting pump between levels
- **Two-speed operation and high by-pass pressure** reduces cycle time for improved productivity
- **Integrated heat exchanger** warms exhaust air to prevent freezing and cools the oil
- **Fine hydraulic pressure adjustment** for accurate torque control
- **Improved wrench speed at low hydraulic pressure** due to the expanded 1st stage bypass setting
- **Pendant** allows operation up to 6 metres (20 ft)
- **Filter-Regulator-Lubricator** with removable bowls and auto drain is standard
- **Calibrated, glycerine filled gauge** with display in bar and psi
- **ATEX-tested and certified.**



Torque Wrench Hoses

Use Enerpac THQ700-Series hoses with torque wrenches to ensure the integrity of your hydraulic system.

For 700 bar	Model Nr.
2 m long, 2 hoses	THQ702T
6 m long, 2 hoses	THQ706T
12 m long, 2 hoses	THQ712T

▼ Certified lifting eye.



PowaPak™ Air Torque Pump



PowaPak™ Air Torque Pump

The ZA4208TX-QROP was developed for the high demands of the oil and gas, chemical processing, rental and other industrial markets.

The stainless-steel roll cage resists corrosion and surface damage reducing the maintenance required to prepare the pump for the next job.

The certified lifting eye enables the pump to be transported between levels with a lifting hook avoiding time consuming strapping.

ATEX-Certified

The ZA4T air-driven torque pump is tested and certified according to the ATEX Directive 2014/34/EU.

The explosion protection is for Equipment Group II, Equipment Category 2 (Hazardous Area Zone 1), in Gas and /or Dust atmospheres.

Each pump contains the following markings:

Ex IIC T4 Gc

Ex IIIC T135°C Dc



ZA4T Series



Reservoir Capacity:

6,8 litres

Flow at Rated Pressure:

1,0 l/min

Air Consumption:

600 - 2840 l/min

Maximum Operating Pressure:

700 bar

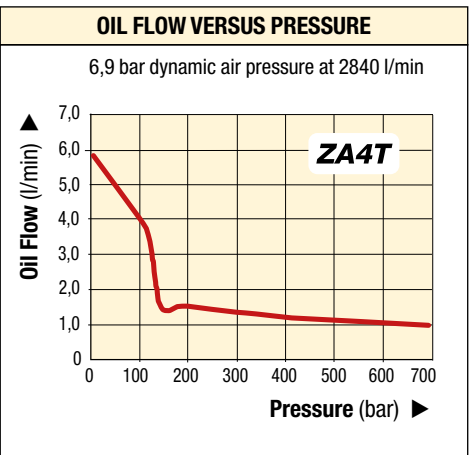
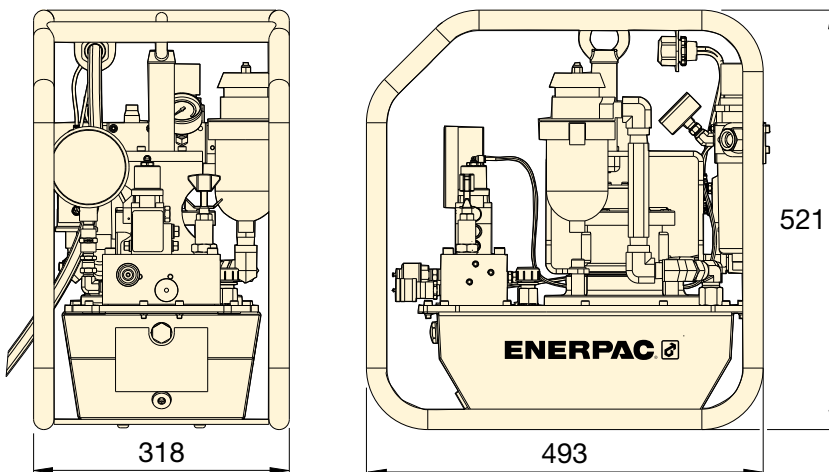

Bolting Integrity Software

Enerpac Bolting Integrity Software Solutions play a key role in implementing and managing an Integrity Program for bolted connections. The software offers Tool selection, Bolt Load calculations and Tool pressure settings, as well as, a combined Application Data Sheet and Joint Completion Report. Custom Joint information can also be entered.

Maximum Operating Pressure (bar)	Model Number	Reservoir Capacity (litres)	Output Flow Rate (l/min)			Dynamic Air Pressure Range (bar)	Air Consumption (l/min)	Weight (kg)
			7 bar	350 bar	700 bar			
700	ZA4208TX-QROP	6,8	5,7	1,3	1,0	4,1-6,9	600-2840	52

▼ HM10 Hydramax® Topside Tensioner



- Fifteen load cells from ¾" to 4" / M20 to M100
- Twin ports for quick connection of multiple tools
- High bolt load capacity at max. 1500 bar (21.750 psi)
- Long stroke capability of 15 mm (9/16 inch) with over stroke elimination
- HM01 to HM05: mechanical over-stroke prevention, no spring assist; HM06 to HM15: relief valve for over-stroke prevention, spring assist
- Quick release bridge
- Stroke indicator
- Captive socket – eliminates falling object risk
- Interchangeable adaptor kits available
- Anti-slip grip for more secure handling
- HM-Series HydraMax® Tensioners comply to following: Machine Directive 2006/42/EC, ASME B30.1, EN-ISO 4413:2010 and EN-ISO 12100:2010.



◀ Enerpac HM-Series HydraMax® tensioners have been designed to generate high bolt loads associated with compact flanges, while providing versatility for maximum bolt coverage,

High Bolt Load Capacities, Superior Performance



HydraMax® Topside Tensioners

The HM-Series tensioners have been designed to fit all standard flanges, including ANSI, API and Compact flanges based on Norsok L005 and generates 30% more load capacity than traditional tensioners.



Tensioning Pumps, Hoses and Couplers

High pressure pumps, hoses and fittings matched for use with the Enerpac Bolt Tensioners.

Page: 219



Ultra-high Pressure

This tool operates at ultra-high pressure, use only the specified fittings and hoses designed for these pressures.

Page: 309



How to Order HydraMax® Tensioners

To provide maximum flexibility Load Cells are ordered separately from Adaptor and Bridge Kits.

Example, to order a complete tensioner for a M24 x 3 threaded bolt order:

1 x Load Cell with tommy bar: **HM03-LC**

1 x Adaptor and Bridge Kit: **HM03BPM-NRS02430**



Bolting Integrity Software

The software offers Tool selection, Bolt Load calculations and Tool pressure settings, as well as, a combined Application data sheet and Joint completion report. Custom Joint information can also be entered.

Page: 422

HydraMax® Topside Tensioners



Thread and Pitch Sizes

Contact Enerpac for different thread or pitch sizes.

Alternative size adaptor kits can be supplied upon request.

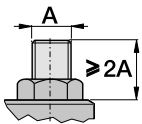

Minimum Stud Protrusion

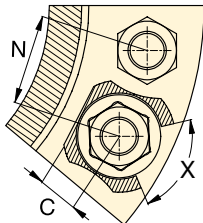

X = Minimum socket rotation 60°

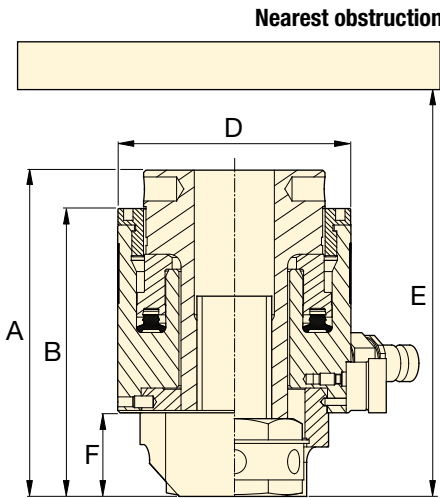

HM Series



Bolt Range:

M20 - M39, 3/4" - 1 1/2"

Maximum Load Capacity:

134 - 624 kN

Stroke:

10 - 15 mm *

Maximum Operating Pressure:

1500 bar

* Stroke HM01 models 10 mm

Strokes all other HM-models 15 mm.

Load Cell Model Number *	Thread Size	Adaptor and Bridge Kit Model Number	Cylinder Effective Area (mm ²)	Maximum Load Capacity (kN)	Dimensions (mm)							Load Cell Weight (kg)	Adaptor and Bridge Kit Weight (kg)
					A	B	C	D	E min.	F	N min.		
HM01-LC	M20 x 2,5	HM01BPM-NRS02025	894	134,0	112	96	15	61	208	28	51	1,6	0,6
	3/4" - 10UN	HM01BP-NRS0750U10	894	134,0	112	96	15	61	208	28	51	1,6	0,6
HM02-LC	M20 x 2,5	HM02BPM-NRS02025	1240	186,0	119	103	15	69	227	28	53	1,8	0,9
	M22 x 2,5	HM02BPM-NRS02225	1240	186,0	119	103	18	69	225	28	54	1,8	0,9
	3/4" - 10UN	HM02BP-NRS0750U10	1240	186,0	119	103	15	69	227	28	52	1,8	0,9
	7/8" - 9UN	HM02BP-NRS0875U09	1240	186,0	119	103	18	69	225	28	56	1,8	0,8
HM03-LC	M20 x 2,5	HM03BPM-NRS02025	1628	244,1	120	105	15	77	230	28	57	2,2	1,1
	M22 x 2,5	HM03BPM-NRS02225	1628	244,1	120	105	18	77	228	28	58	2,2	1,1
	M24 x 3	HM03BPM-NRS02430	1628	244,1	120	110	20	77	232	33	59	2,2	1,1
	3/4" - 10UN	HM03BP-NRS0750U10	1628	244,1	120	105	15	77	230	28	56	2,2	1,1
	7/8" - 9UN	HM03BP-NRS0875U09	1628	244,1	120	105	18	77	228	28	58	2,2	1,1
	1" - 8UN	HM03BP-NRS1000U08	1628	244,1	125	110	20	77	232	33	60	2,2	1,1
HM04-LC	M22 x 2,5	HM04BPM-NRS02225	2159	323,8	128	112	18	90	250	28	62	2,7	1,6
	M24 x 3	HM04BPM-NRS02430	2159	323,8	129	117	20	90	255	33	63	2,7	1,6
	M27 x 3	HM04BPM-NRS02730	2159	323,8	134	117	20	90	256	34	65	2,7	1,7
	M30 x 3,5	HM04BPM-NRS03035	2159	323,8	137	120	23	90	257	36	66	2,7	1,7
	7/8" - 9UN	HM04BP-NRS0875U09	2159	323,8	129	112	18	90	250	28	62	2,7	1,6
	1" - 8UN	HM04BP-NRS1000U08	2159	323,8	134	117	20	90	255	33	64	2,7	1,7
	1 1/8" - 8UN	HM04BP-NRS1125U08	2159	323,8	137	120	23	90	257	36	65	2,7	1,7
HM05-LC	M24 x 3	HM05BPM-NRS02430	2752	412,7	131	119	20	99	263	33	68	3,3	1,9
	M27 x 3	HM05BPM-NRS02730	2752	412,7	136	119	20	99	263	34	69	3,3	2,0
	M30 x 3,5	HM05BPM-NRS03035	2752	412,7	139	122	23	99	261	36	71	3,3	2,0
	M33 x 3,5	HM05BPM-NRS03335	2752	412,7	142	125	27	99	262	39	72	3,3	2,1
	1" - 8UN	HM05BP-NRS1000U08	2752	412,7	136	119	20	99	263	33	68	3,3	2,1
	1 1/8" - 8UN	HM05BP-NRS1125U08	2752	412,7	139	122	23	99	261	36	70	3,3	2,1
	1 1/4" - 8UN	HM05BP-NRS1250U08	2752	412,7	142	125	27	99	262	39	71	3,3	2,1
HM06-LC	M30 x 3,5	HM06BPM-NRS03035	4162	624,1	143	125	23	118	266	36	80	4,5	2,8
	M33 x 3,5	HM06BPM-NRS03335	4162	624,1	146	128	27	118	269	39	82	4,5	2,9
	M36 x 4	HM06BPM-NRS03640	4162	624,1	149	131	32	118	273	42	83	4,5	3,0
	M39 x 4	HM06BPM-NRS03940	4162	624,1	152	134	33	118	277	45	85	4,5	3,1
	1 1/8" - 8UN	HM06BP-NRS1125U08	4162	624,1	143	125	23	118	266	36	79	4,5	2,8
	1 1/4" - 8UN	HM06BP-NRS1250U08	4162	624,1	146	128	27	118	269	39	81	4,5	2,9
	1 3/8" - 8UN	HM06BP-NRS1375U08	4162	624,1	149	131	32	118	273	32	82	4,5	3,0
	1 1/2" - 8UN	HM06BP-NRS1500U08	4162	624,1	152	134	33	118	277	45	84	4,5	3,1

* Tommy Bar is included with Load Cell.



Thread and Pitch Sizes

Contact Enerpac for different thread or pitch sizes. Alternative size adaptor kits can be supplied upon request.

HM Series



Bolt Range:

M33 - M52, 1¼ - 2"

Maximum Load Capacity:

746 - 1179 kN

Stroke:

15 mm

Maximum Operating Pressure:

1500 bar

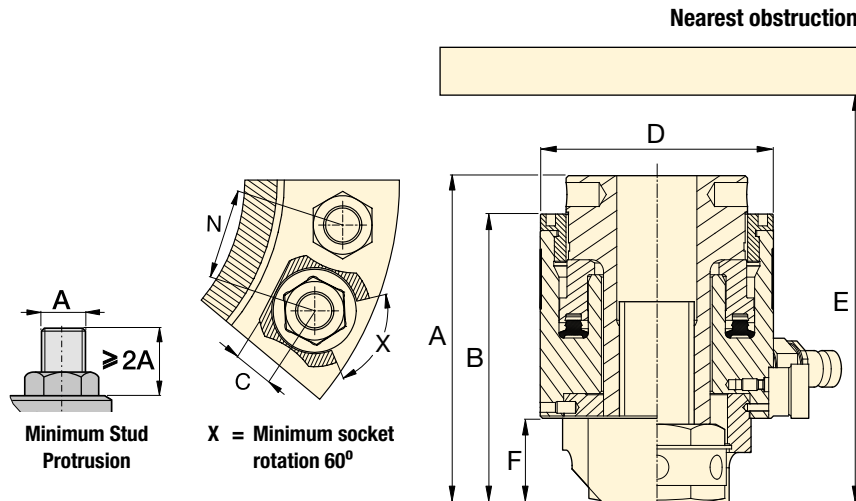

Load Cell Model Number *	Thread Size	Adaptor and Bridge Kit Model Number	Cylinder Effective Area (mm ²)	Maximum Load Capacity (kN)	Dimensions (mm)							Load Cell Weight (kg)	Adaptor and Bridge Kit Weight (kg)
					A	B	C	D	E min.	F	N min.		
HM07-LC	M33 x 3,5	HM07BPM-NRS03335	4980	746,8	145	128	27	127	278	39	86	5,2	3,4
	M36 x 4	HM07BPM-NRS03640	4980	746,8	148	131	32	127	279	42	88	5,2	3,5
	M39 x 4	HM07BPM-NRS03940	4980	746,8	151	134	33	127	280	45	89	5,2	3,6
	M42 x 4,5	HM07BPM-NRS04245	4980	746,8	154	137	34	127	280	48	91	5,2	3,7
	1¼" - 8UN	HM07BP-NRS1250U08	4980	746,8	145	128	27	127	278	39	85	5,2	3,4
	1⅝" - 8UN	HM07BP-NRS1375U08	4980	746,8	148	131	32	127	279	42	87	5,2	3,5
	1½" - 8UN	HM07BP-NRS1500U08	4980	746,8	151	134	33	127	280	45	89	5,2	3,6
1⅞" - 8UN	HM07BP-NRS1625U08	4980	746,8	154	137	34	127	280	48	90	5,2	3,7	
HM08-LC	M36 x 4	HM08BPM-NRS03640	5869	880,1	149	133	32	137	283	42	93	6,3	3,9
	M39 x 4	HM08BPM-NRS03940	5869	880,1	152	136	33	137	284	45	94	6,3	4,0
	M42 x 4,5	HM08BPM-NRS04245	5869	880,1	155	139	34	137	284	48	96	6,3	4,1
	M45 x 4,5	HM08BPM-NRS04545	5869	880,1	158	142	39	137	285	51	97	6,3	4,4
	1⅝" - 8UN	HM08BP-NRS1375U08	5869	880,1	149	133	32	137	283	42	92	6,3	3,9
	1½" - 8UN	HM08BP-NRS1500U08	5869	880,1	152	136	33	137	284	45	94	6,3	4,0
	1⅞" - 8UN	HM08BP-NRS1625U08	5869	880,1	155	139	34	137	284	48	95	6,3	4,1
1¾" - 8UN	HM08BP-NRS1750U08	5869	880,1	158	142	39	137	285	51	97	6,3	4,4	
HM09-LC	M39 x 4	HM09BPM-NRS03940	6834	1024,9	152	136	33	145	278	45	98	6,5	5,0
	M42 x 4,5	HM09BPM-NRS04245	6834	1024,9	155	139	34	145	281	48	100	6,5	6,1
	M45 x 4,5	HM09BPM-NRS04545	6834	1024,9	158	142	39	145	285	51	101	6,5	5,1
	M48 x 5	HM09BPM-NRS04850	6834	1024,9	161	145	43	145	288	54	103	6,5	5,5
	1½" - 8UN	HM09BP-NRS1500U08	6834	1024,9	152	136	33	145	278	45	98	6,5	5,1
	1⅝" - 8UN	HM09BP-NRS1625U08	6834	1024,9	155	139	34	145	281	48	99	6,5	5,1
	1¾" - 8UN	HM09BP-NRS1750U08	6834	1024,9	158	142	39	145	285	51	101	6,5	5,0
1⅞" - 8UN	HM09BP-NRS1875U08	6834	1024,9	161	145	43	145	288	54	102	6,5	5,4	
HM10-LC	M42 x 4,5	HM10BPM-NRS04245	7868	1179,8	159	143	34	156	289	48	105	8,3	5,7
	M45 x 4,5	HM10BPM-NRS04545	7868	1179,8	162	146	39	156	293	51	107	8,3	5,7
	M48 x 5	HM10BPM-NRS04850	7868	1179,8	165	149	43	156	296	54	108	8,3	6,1
	M52 x 5	HM10BPM-NRS05250	7868	1179,8	169	153	44	156	301	58	110	8,3	6,3
	1⅝" - 8UN	HM10BP-NRS1625U08	7868	1179,8	159	143	34	156	289	48	105	8,3	5,7
	1¾" - 8UN	HM10BP-NRS1750U08	7868	1179,8	162	146	39	156	293	51	106	8,3	5,6
	1⅞" - 8UN	HM10BP-NRS1875U08	7868	1179,8	165	149	43	156	296	54	108	8,3	6,0
2" - 8UN	HM10BP-NRS2000U08	7868	1179,8	169	153	44	156	301	58	109	8,3	6,3	

* Load Cell with Tommy Bar.

HydraMax® Topside Tensioners

HM Series



Bolt Range:

M45 - M100, 1 3/4" - 4"

Maximum Load Capacity at 1500 bar:

1522 - 4650 kN

Stroke:

15 mm

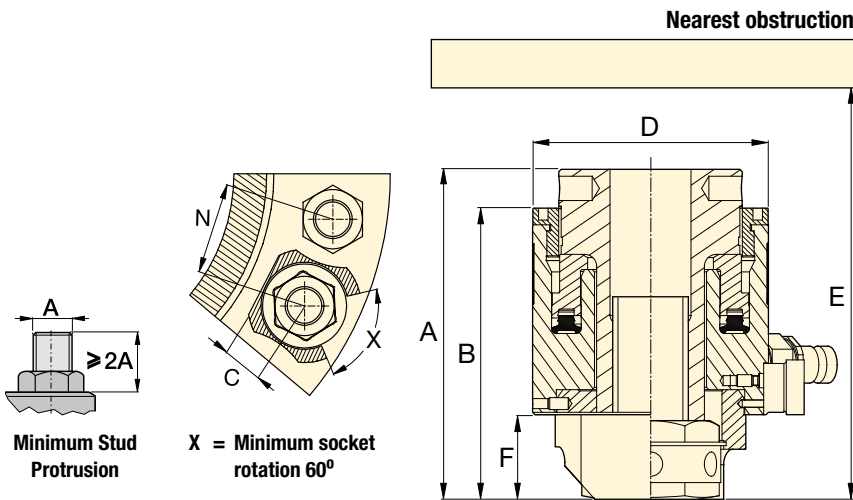

Load Cell Model Number *	Thread Size **	Adaptor and Bridge Kit Model Number	Cylinder Effective Area (mm ²)	Maximum Load Capacity (kN)	Dimensions (mm)							Load Cell Weight (kg)	Adaptor and Bridge Kit Weight (kg)
					A	B	C	D	E min.	F	N min.		
HM11-LC	M45 x 4,5	HM11BPM-NRS04545	10152	1522,5	167	146	39	175	297	51	116	10,5	7,4
	M48 x 5	HM11BPM-NRS04850	10152	1522,5	170	149	43	175	301	54	118	10,5	7,9
	M52 x 5	HM11BPM-NRS05250	10152	1522,5	174	153	44	175	306	58	120	10,5	8,1
	M56 x 5,5	HM11BPM-NRS05655	10152	1522,5	182	161	50	175	318	66	122	10,5	9,1
	M60 x 5,5	HM11BPM-NRS06055	10152	1522,5	182	161	50	175	323	66	124	10,5	8,7
	1 3/8" - 8UN	HM11BP-NRS1750U08	10152	1522,5	167	146	39	175	297	51	116	10,5	7,5
	1 7/8" - 8UN	HM11BP-NRS1875U08	10152	1522,5	170	149	43	175	301	54	117	10,5	7,9
	2" - 8UN	HM11BP-NRS2000U08	10152	1522,5	174	153	44	175	306	58	119	10,5	8,1
2 1/4" - 8UN	HM11BP-NRS2250U08	10152	1522,5	182	161	50	175	318	66	122	10,5	8,8	
HM12-LC	M48 x 5	HM12BPM-NRS04850	12722	1907,7	170	149	43	194	301	54	127	13,3	9,7
	M52 x 5	HM12BPM-NRS05250	12722	1907,7	174	153	44	194	306	58	129	13,3	9,8
	M56 x 5,5	HM12BPM-NRS05655	12722	1907,7	182	161	50	194	318	66	131	13,3	10,7
	M60 x 5,5	HM12BPM-NRS06055	12722	1907,7	182	161	50	194	323	66	133	13,3	10,4
	M64 x 6	HM12BPM-NRS06460	12722	1907,7	186	165	56	194	320	70	135	13,3	11,1
	1 7/8" - 8UN	HM12BP-NRS1875U08	12722	1907,7	170	149	43	194	301	54	127	13,3	9,6
	2" - 8UN	HM12BP-NRS2000U08	12722	1907,7	174	153	44	194	306	58	128	13,3	9,8
	2 1/4" - 8UN	HM12BP-NRS2250U08	12722	1907,7	182	161	50	194	318	66	132	13,3	10,4
2 1/2" - 8UN	HM12BP-NRS2500U08	12722	1907,7	186	165	56	194	320	70	135	13,3	10,8	
HM13-LC	M64 x 6	HM13BPM-NRS06460	16964	2544,0	195	172	56	219	337	70	148	17,6	14,5
	M68 x 6	HM13BPM-NRS06860	16964	2544,0	195	180	63	219	350	78	150	17,6	16,5
	M72 x 6	HM13BPM-NRS07260	16964	2544,0	203	185	69	219	347	82	152	17,6	16,0
	M76 x 6	HM13BPM-NRS07660	16964	2544,0	207	185	69	219	352	82	154	17,6	16,3
	2 1/2" - 8UN	HM13BP-NRS2500U08	16964	2544,0	195	172	56	219	337	70	147	17,6	14,2
	2 3/4" - 8UN	HM13BP-NRS2750U08	16964	2544,0	203	180	63	219	350	78	150	17,6	15,8
3" - 8UN	HM13BP-NRS3000U08	16964	2544,0	207	185	69	219	352	82	161	17,6	15,8	
HM14-LC	M72 x 6	HM14BPM-NRS07260	23451	3516,7	203	185	69	259	351	82	172	25,8	20,8
	M76 x 6	HM14BPM-NRS07660	23451	3516,7	207	185	69	259	352	82	174	25,8	21,3
	M80 x 6	HM14BPM-NRS08060	23451	3516,7	207	193	70	259	367	91	176	25,8	21,2
	M85 x 6	HM14BPM-NRS08560	23451	3516,7	216	193	70	259	374	91	178	25,8	22,9
	M90 x 6	HM14BPM-NRS09060	23451	3516,7	221	198	79	259	389	96	181	25,8	23,3
	3" - 8UN	HM14BP-NRS3000U08	23451	3516,7	207	185	69	259	352	82	174	25,8	20,4
	3 1/4" - 8UN	HM14BP-NRS3250U08	23451	3516,7	216	193	70	259	374	91	177	25,8	22,7
3 1/2" - 8UN	HM14BP-NRS3500U08	23451	3516,7	221	198	79	259	389	96	184	25,8	23,9	
HM15-LC	M90 x 6	HM15BPM-NRS09060	31008	4650,0	221	199	79	296	389	96	199	32,5	30,0
	M95 x 6	HM15BPM-NRS09560	31008	4650,0	226	205	81	296	405	101	202	32,5	33,7
	M100 x 6	HM15BPM-NRS10060	31008	4650,0	232	211	90	296	421	107	204	32,5	35,1
	3 1/2" - 8UN	HM15BP-NRS3500U08	31008	4650,0	221	199	79	296	389	96	198	32,5	29,5
	3 3/4" - 8UN	HM15BP-NRS3750U08	31008	4650,0	226	205	81	296	405	101	202	32,5	32,8
	4" - 8UN	HM15BP-NRS4000U08	31008	4650,0	232	211	90	296	421	107	210	32,5	34,0

* Load Cell with Tommy Bar.

** Contact Enerpac for different thread or pitch sizes. Alternative size adaptor kits can be supplied upon request.

▼ Shown: GT-Series Topside Bolt Tensioners



- Seven load cells from M16 to M105 or from 5/8" to 4"
- Twin ports for quick connection of multiple tools
- Only one size of bridge per size of load cell
- Detachable and rotational bridge simplifies tool positioning
- Full bridge window – increased access to socket
- Captive socket – eliminates falling object risk
- Piston stroke indicator
- Black surface treatment protects against corrosion
- Anti-slip grip for more secure handling
- Universal and multi-use tool
- GT-Series Tensioners comply to Machine Directive 2006/42/CE, ASME B30.1, EN-ISO 4413:2010 and EN-ISO 12100:2010.

Accurate & Reliable Extreme Performance Bolt Tensioners



Tensioning Pumps, Hoses and Couplers

High pressure pumps, hoses and fittings matched for use with the Enerpac Bolt Tensioners.

Page: 309



Bolting Integrity Software

The software offers Tool selection, Bolt Load calculations and Tool pressure settings, as well as, a combined Application data sheet and Joint completion report. Custom Joint information can also be entered.

Page: 422



How to Order

To provide maximum flexibility Load Cell and Bridges are ordered separately from Adaptor Kits.

Example, to order a complete tensioner for a M36 x 4 threaded bolt order:

1 x Load Cell and Bridge: **GT2-LCB**

1 x Adaptor Kit: **GT2PM-NRS03640**

Load Cell * and Bridge Model Number	Thread Size	Adaptor Kit Model Number	Cylinder Effective Area (mm ²)	Maximum Load Capacity (kN)	Dimensions (mm)							Load Cell and Bridge Weight (kg)	Adaptor Kit Weight (kg)
					A	B	C	D	E min.	F	N min.		
GT1-LCB	M16 x 2	GT1PM-NRS01620	1495,4	224,3	135	113	27	86	243	44	57	3,0	1,6
	M18 x 2,5	GT1PM-NRS01825	1495,4	224,3	135	113	27	86	243	44	58	3,0	1,5
	M20 x 2,5	GT1PM-NRS02025	1495,4	224,3	135	113	27	86	243	44	59	3,0	1,4
	M24 x 3	GT1PM-NRS02430	1495,4	224,3	135	113	27	86	243	44	61	3,0	1,3
	M27 x 3	GT1PM-NRS02730	1495,4	224,3	135	113	27	86	243	44	64	3,0	1,2
	M30 x 3,5	GT1PM-NRS03035	1495,4	224,3	135	113	27	86	243	44	66	3,0	1,0
	5/8" - 11UN	GT1P-NRS0625U11	1495,4	224,3	135	113	27	86	243	44	57	3,0	1,6
	3/4" - 10UN	GT1P-NRS0750U10	1495,4	224,3	135	113	27	86	243	44	59	3,0	1,4
	7/8" - 9UN	GT1P-NRS0875U09	1495,4	224,3	135	113	27	86	243	44	62	3,0	1,3
1" - 8UN	GT1P-NRS1000U08	1495,4	224,3	135	113	27	86	243	44	64	3,0	1,2	
1 1/8" - 8UN	GT1P-NRS1125U08	1495,4	224,3	135	113	27	86	243	44	66	3,0	1,0	
GT2-LCB	M30 x 3,5	GT2PM-NRS03035	2677,2	401,5	136	111	35	107	226	41	75	4,1	2,6
	M33 x 3,5	GT2PM-NRS03335	2677,2	401,5	136	111	35	107	226	41	76	4,1	2,4
	M36 x 4	GT2PM-NRS03640	2677,2	401,5	136	111	35	107	226	41	79	4,1	2,2
	M39 x 4	GT2PM-NRS03940	2677,2	401,5	136	111	35	107	226	41	82	4,1	1,9
	1 1/8" - 8UN	GT2P-NRS1125U08	2677,2	401,5	136	111	35	107	226	41	74	4,1	2,6
	1 1/4" - 8UN	GT2P-NRS1250U08	2677,2	401,5	136	111	35	107	226	41	76	4,1	2,4
	1 3/8" - 8UN	GT2P-NRS1375U08	2677,2	401,5	136	111	35	107	226	41	79	4,1	2,2
	1 1/2" - 8UN	GT2P-NRS1500U08	2677,2	401,5	136	111	35	107	226	41	82	4,1	2,0

* Load Cell with tommy bar.

Topside Bolt Tensioners



Thread and Pitch Sizes

Contact Enerpac for different thread or pitch sizes. Alternative size adaptor kits can be supplied upon request.

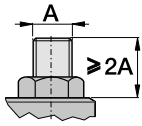

Minimum Stud Protrusion

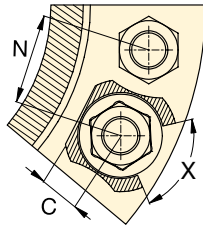

X = Minimum socket rotation 60°

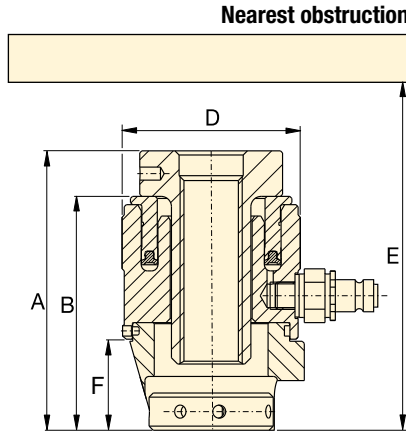

GT Series



Bolt Range:

M16 - M105, 5/8" - 4"

Maximum Load Capacity at 1500 bar:

224 - 3958 kN

Stroke:

10 mm

Maximum Operating Pressure:

1500 bar

Load Cell * and Bridge Model Number	Thread Size	Adaptor Kit Model Number	Cylinder Effective Area (mm ²)	Maximum Load Capacity (kN)	Dimensions (mm)							Load Cell and Bridge Weight (kg)	Adaptor Kit Weight (kg)
					A	B	C	D	E min.	F	N min.		
GT3-LCB	M39 x 4	GT3PM-NRS03940	5127,1	768,9	160	126	46	138	256	56	96	7,0	5,7
	M42 x 4,5	GT3PM-NRS04245	5127,1	768,9	160	126	46	138	256	56	98	7,0	5,4
	M45 x 4,5	GT3PM-NRS04545	5127,1	768,9	160	126	46	138	256	56	101	7,0	5,0
	M48 x 5	GT3PM-NRS04850	5127,1	768,9	160	126	46	138	256	56	104	7,0	4,7
	M52 x 5	GT3PM-NRS05250	5127,1	768,9	160	126	46	138	256	56	107	7,0	4,2
	1 1/2" - 8UN	GT3P-NRS1500U08	5127,1	768,9	160	126	46	138	256	56	95	7,0	5,7
	1 5/8" - 8UN	GT3P-NRS1625U08	5127,1	768,9	160	126	46	138	256	56	98	7,0	5,3
	1 3/4" - 8UN	GT3P-NRS1750U08	5127,1	768,9	160	126	46	138	256	56	101	7,0	5,0
GT4-LCB	1 7/8" - 8UN	GT3P-NRS1875U08	5127,1	768,9	160	126	46	138	256	56	104	7,0	4,6
	2" - 8UN	GT3P-NRS2000U08	5127,1	768,9	160	126	46	138	256	56	106	7,0	4,2
	M52 x 5	GT4PM-NRS05250	9782,1	1466,9	180	141	62	174	281	71	121	12,2	10,7
	M56 x 5,5	GT4PM-NRS05655	9782,1	1466,9	180	141	62	174	281	71	124	12,2	10,1
	M60 x 5,5	GT4PM-NRS06055	9782,1	1466,9	180	141	62	174	281	71	127	12,2	9,4
	M64 x 6	GT4PM-NRS06460	9782,1	1466,9	180	141	62	174	281	71	129	12,2	8,8
	M68 x 6	GT4PM-NRS06860	9782,1	1466,9	180	141	62	174	281	71	132	12,2	8,1
	2" - 8UN	GT4P-NRS2000U08	9782,1	1466,9	180	141	62	174	281	71	120	12,2	10,7
GT5-LCB	2 1/4" - 8UN	GT4P-NRS2250U08	9782,1	1466,9	180	141	62	174	281	71	126	12,2	9,7
	2 1/2" - 8UN	GT4P-NRS2500U08	9782,1	1466,9	180	141	62	174	281	71	132	12,2	8,5
	M68 x 6	GT5PM-NRS06860	15079,7	2261,4	202	157	78	210	302	86	148	18,7	17,3
	M72 x 6	GT5PM-NRS07260	15079,7	2261,4	202	157	78	210	302	86	149	18,7	16,4
	M76 x 6	GT5PM-NRS07660	15079,7	2261,4	202	157	78	210	302	86	152	18,7	15,5
	M80 x 6	GT5PM-NRS08060	15079,7	2261,4	202	157	78	210	302	86	155	18,7	14,6
	2 1/2" - 8UN	GT5P-NRS2500U08	15079,7	2261,4	202	157	78	210	302	86	148	18,7	17,8
	2 3/4" - 8UN	GT5P-NRS2750U08	15079,7	2261,4	202	157	78	210	302	86	153	18,7	16,3
GT6-LCB	3" - 8UN	GT5P-NRS3000U08	15079,7	2261,4	202	157	78	210	302	86	158	18,7	14,8
	3 1/4" - 8UN	GT5P-NRS3250U08	15079,7	2261,4	202	157	78	210	302	86	161	18,7	13,1
	M80 x 6	GT6PM-NRS08060	18972,1	2845,1	219	173	82	240	323	95	167	27,8	22,3
	M85 x 6	GT6PM-NRS08560	18972,1	2845,1	219	173	82	240	323	95	170	27,8	21,0
	M90 x 6	GT6PM-NRS09060	18972,1	2845,1	219	173	82	240	323	95	175	27,8	19,4
	M95 x 6	GT6PM-NRS09560	18972,1	2845,1	219	173	82	240	323	95	179	27,8	18,0
	3 1/4" - 8UN	GT6P-NRS3250U08	18972,1	2845,1	219	173	82	240	323	95	173	27,8	20,7
GT7-LCB	3 1/2" - 8UN	GT6P-NRS3500U08	18972,1	2845,1	219	173	82	240	323	95	181	27,8	18,8
	3 3/4" - 8UN	GT6P-NRS3750U08	18972,1	2845,1	219	173	82	240	323	95	188	27,8	16,8
	M100 x 6	GT7PM-NRS10060	26389,4	3958,4	243	182	89	277	332	110	196	38,2	28,5
GT7-LCB	M105 x 6	GT7PM-NRS10560	26389,4	3958,4	243	182	89	277	332	110	199	38,2	27,3
	4" - 8UN	GT7P-NRS4000U08	26389,4	3958,4	243	182	89	277	332	110	204	38,2	27,3

* Load Cell with tommy bar.

▼ Aquajack® Tensioner EAJ2LC with Quick Fastening Nut



- Compact design
- Long piston stroke
- Misalignment compensation
- Quick, simple hose connection
- Visible piston stroke indication
- 'No spill' overstroke elimination
- Quick fastening or solid reaction nut.

▼ Guaranteed to save time and increase efficiency, Aquajack® tensioners improve diver safety, productivity and reduce diver fatigue.



The most cost effective solution to subsea bolt or stud tightening



Quick Fastening Nut Design

Easily positioned in poor visibility conditions, Aquajack® subsea tensioners feature a compact design and long piston stroke.

The unique Split Nut® design of these tools allows rapid application to long bolts and damaged threads, and rapid tool removal.



No Oil Spillage or Over-Stroking

Innovative tool design ensures maximum tool strokes can be used without over stroking the piston or oil spillage. Guaranteed to save time and increase efficiency, Aquajack® subsea tensioners improve diver safety, productivity and reduce diver fatigue.

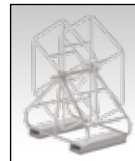
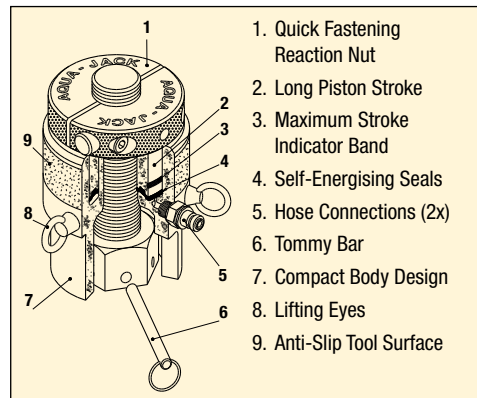

Hose Reels and Stand

Stainless steel stand with 1500 bar hoses from 30 upto 270 metres lengths. All hose reels are built up with multiple 30 metres length hoses.

Aquajack® Subsea Tensioners

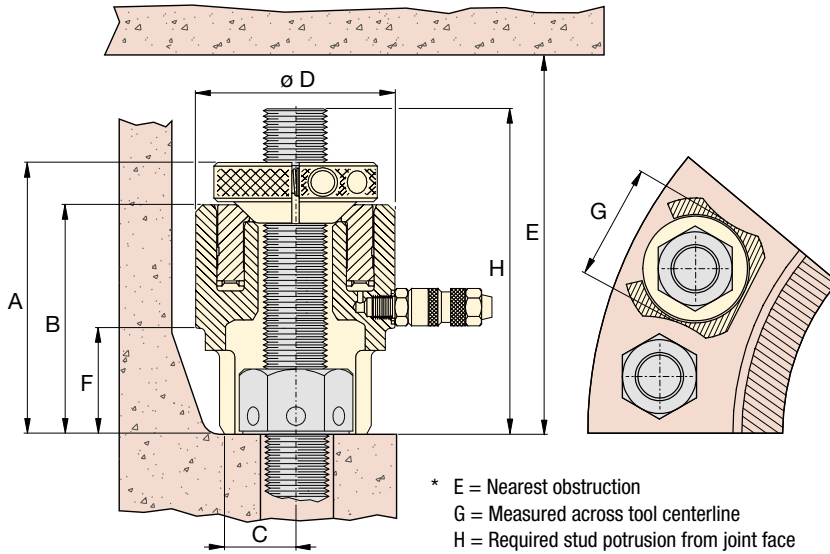

EAJ Series



Bolt Range:

M20 - M90 | 3/4 - 3 1/2 inch

Maximum Load Capacity:

151,3 - 2320,9 kN

Maximum Operating Pressure:

1500 bar

Load Cell Model Number **	Thread Size	Quick Fastening Nut Model Number	Cylinder Effective Area (mm ²)	Maximum Load Capacity (kN)	Stroke (mm)	Dimensions (mm)								Tool Weight (kg)
						A	B	C	D	E*	F	G*	H*	
EAJ1LC	3/4" - 10 UN	EAJ1QFN0750U10	1008,7	151,3	20	114	91	19	66	217	35	53	119	1,5
	7/8" - 9 UN	EAJ1QFN0875U09												
	M20 x 2,5	EAJ1QFNM02025												
	M22 x 2,5	EAJ1QFNM02225												
EAJ2LC	1" - 8 UN	EAJ2QFN1000U08	1658,4	248,7	30	147	120	25	82	289	50	62	152	3,0
	M24 x 2,5	EAJ2QFNM02425												
	M27 x 3,0	EAJ2QFNM02730												
	1 1/8" - 8 UN	EAJ2QFN1125U08												
EAJ3LC	M30 x 3,5	EAJ2QFNM03035	2524,3	378,6	30	158	131	28	98	307	58	78	163	4,5
	1 1/4" 8 UN	EAJ3QFN1250U08												
	M33 x 3,5	EAJ3QFNM03335												
	1 3/8" - 8 UN	EAJ3QFN1375U08												
EAJ4LC	M36 x 4,0	EAJ3QFNM03640	3686,7	553,0	30	171	136	33	114	319	63	91	176	6,0
	1 1/2" - 8 UN	EAJ4QFN1500U08												
	M39 x 4,0	EAJ4QFNM03940												
	1 5/8" - 8 UN	EAJ4QFN1625U08												
EAJ5LC	M42 x 4,5	EAJ4QFNM04245	5908,7	886,3	30	184	146	40	139	342	70	114	189	9,0
	1 3/4" - 8 UN	EAJ5QFN1750U08												
	M45 x 4,5	EAJ5QFNM04545												
	1 7/8" - 8 UN	EAJ5QFN1875U08												
	M48 x 5,0	EAJ5QFNM04850												
EAJ6LC	2" - 8 UN	EAJ5QFN2000U08	8312,8	1246,9	30	201	161	49	164	367	82	138	206	13,0
	M52 x 5,0	EAJ5QFNM05250												
	M56 x 5,5	EAJ6QFNM05655												
	2 1/4" - 8 UN	EAJ6QFN2250U08												
EAJ7LC	M60 x 5,5	EAJ6QFNM06055	12.369,0	1855,4	30	230	178	75	192	400	95	154	235	19,0
	M64 x 6,0	EAJ6QFNM06460												
	M68 x 6,0	EAJ7QFNM06860												
	2 3/4" - 8 UN	EAJ7QFN2750U08												
EAJ8LC	M72 x 6,0	EAJ7QFNM07260	15.473,0	2320,9	30	247	193	68	216	412	109	182	252	24,5
	M76 x 6,0	EAJ7QFNM07660												
	3" - 8 UN	EAJ7QFN3000U08												
	M80 x 6,0	EAJ8QFNM08060												
	3 1/4" - 8 UN	EAJ8QFN3250U08												
M85 x 6,0	EAJ8QFNM08560													
M90 x 6,0	EAJ8QFNM09060													

** Tommy Bar included with Load Cell.

▼ PGT-Series Single Stage and Double Deck Tensioners



High Precision, Low Maintenance



Tensioning Pumps

Electric, pneumatic and manual high-pressure tensioning pumps are available for use with Enerpac hydraulic tensioners.



Hoses and Fittings

High-pressure hoses and fittings for use with Enerpac tensioning systems are available.

Page: 309

- PGT-Series Bolt Tensioners are designed for critical fastening applications in wind, steam and gas turbines
- A broad range of single stage and double deck tensioners provide high performance in tight spaces associated with Power Generation applications
- PGT-Series Bolt Tensioners are loaded with performance enhancing features such as Auto-Retract Pistons, Cycle Counters and a premium coating to offer the ultimate in efficiency, durability and ease of use.

Description	PGTS Single Stage	PGTD Double Deck
Auto-Retract Piston	✓	✓
Zinc Coating	✓	✓
Geared Nut-Run-down	✓	✓
Over-stroke Indicator	✓	✓
Over-stroke Preventer	✓	✓
Single Male Fitting	✓	✓
Swivel Manifold	+	+
Cycle Counter	-	+

✓ = Standard on tensioner

⊕ = Possible option

- = Option not available

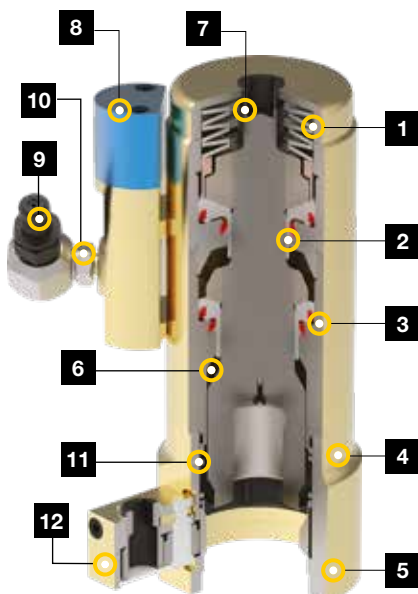

1. **Auto-retract piston:** Simplifies use and improves speed of operation.
2. **Long-life puller:** For maximum durability.
3. **Long-life seals:** For maximum durability and extended service life intervals.
4. **Corrosion protection:** Zinc coating provides best-in-class corrosion resistance.
5. **Interchangeable bridge:** For optimal application fit.
6. **Over-stroke preventer:** Mechanically prevents over-stroke, extending cylinder life.
7. **Over-stroke indicator:** Extends cylinder life by helping to prevent over-stroking of cylinder.
8. **Optional counter:** Helps indicate when maintenance is due to maximize uptime.
9. **Quick-disconnect coupler:** For safe, simple hydraulic connection.
10. **Optional 360° swivel:** available for additional hose positioning flexibility.
11. **Spring-loaded nut engagement:** Keeps socket positioned on nut for faster and easier seating process.
12. **Gearbox:** for nut run down. Easy and quick nut run down back to the flange

▲ The model above illustrates a typical tool configuration. Actual model configurations vary.

Power Generation Bolt Tensioners



Options

Fitting Type

SW = Swivel manifold with single male fitting
Example: **PGTS2436SW**

Cycle-Counter

C = Cycle Counter (not available on PGTS-models)
Example: **PGTD3655SWC**

- ① Puller bar square drive
- ② Swivel manifold with single male fitting
- ③ Single male fitting
- ④ Nut run down gear box

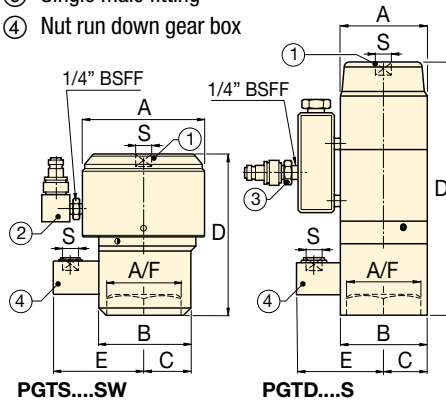

PGT Series



Bolt Range:

M20 - M72

Maximum Load Capacity:

203,7 - 2969,6 kN

Maximum Operating Pressure ¹⁾:

1350 - 1500 bar

¹⁾ Max. pressure varies, see specifications table for details.

Tensioner Type	Thread Diameter (mm)	Model Number with single male fitting	Nut Size A/F (mm)	Maximum Pressure (bar)	Hydraulic Pressure Area (mm ²)	Maximum Load Capacity (kN)	Stroke (mm)	Dimensions (mm)						Bolt Potrusion (mm)		
								A	B	C	D	E	S* (inch)		min.	max.
Single Stage	M20 x 2,5	PGTS2030S	30	1500	1358	203,7	7,0	64	64	32	81	78	3/8	2,0	44	55
	M24 x 3,0	PGTS2436S	36	1500	1947	292,1	7,0	77	77	31	98	81	3/8	2,9	49	62
	M27 x 3,0	PGTS2742S	42	1500	2646	396,9	8,0	92	75	34	129	83	3/8	4,8	60	70
	M30 x 3,5	PGTS3046S	46	1500	3204	480,7	8,0	99	85	38	134	88	3/8	5,8	68	73
	M33 x 3,5	PGTS3350S	50	1500	3960	594,0	8,0	106	90	40	142	90	3/8	6,8	75	100
	M36 x 4,0	PGTS3655S	55	1500	4467	670,1	9,0	111	90	56	128	95	1/2	6,4	71	95
	M39 x 4,0	PGTS3960S	60	1500	5561	834,1	10,0	123,5	104	46	160	96	3/8	9,8	89	115
	M42 x 4,5	PGTS4265S	65	1500	6259	938,8	10,0	134	115	67	177	99	1/2	9,5	79	115
	M45 x 4,5	PGTS4570S	70	1500	7505	1125,8	10,0	143	119	53	168	102	3/8	13,2	98	116
	M48 x 5,0	PGTS4875S	75	1500	8390	1258,4	10,0	152	125	56	158	106	3/8	13,3	103	119
	M52 x 5,0	PGTS5280S	80	1500	10.094	1514,1	10,0	165	134	59	171	108	3/8	17,9	106	118
	M56 x 5,5	PGTS5685S	85	1500	11.663	1749,5	10,0	177	142	62	170	112	3/8	20,4	116	128
	M60 x 5,5	PGTS6090S	90	1500	13.474	2021,2	10,0	190	152	66	186	115	3/8	24,8	123,5	137
	M64 x 6,0	PGTS6495S	95	1500	15.315	2297,3	10,0	200	159	69	207	118	1/2	30,7	137	150
M68 x 6,0	PGTS68100S	100	1500	17.493	2623,9	10,0	213,5	169	73	206	123	1/2	34,3	136	148	
M72 x 6,0	PGTS72105S	105	1500	19.797	2969,6	10,0	225	178	76	223	126	1/2	40,3	151	167	
Double Deck	M24 x 3,0	PGTD2436S	36	1350	2293	309,6	6,0	61,5	77	31	185	81	3/8	4,6	53	59,5
	M27 x 3,0	PGTD2742S	42	1350	2939	396,8	6,0	68	75	34	196	83,4	3/8	5,3	60	68
	M30 x 3,5	PGTD3046S	46	1350	3426	462,6	7,0	73	85	37	195	88	3/8	5,8	60	70
	M33 x 3,5	PGTD3350S	50	1350	4272	576,7	7,0	78	77	38,5	208	90	3/8	6,7	65	77
	M36 x 4,0	PGTD3655S	55	1350	4995	674,3	8,0	84	83	41	218	93	1/2	7,7	70	87
	M39 x 4,0	PGTD3960S	60	1350	6260	845,0	10,0	95	104	48	266	96	3/8	12,5	84	93
	M42 x 4,5	PGTD4265S	65	1350	6865	926,8	10,0	98	104	52	248,4	99	1/2	11,4	82	91
	M45 x 4,5	PGTD4570S	70	1350	8339	1125,8	10,0	108	119	53	294	104	3/8	17,7	97	107
	M48 x 5,0	PGTD4875S	75	1350	9430	1273,1	10,0	115	125	57,5	304	106	3/8	20,1	103	113
	M52 x 5,0	PGTD5280S	80	1350	11.288	1523,8	10,0	124	134	61	328	108	3/8	26,1	110	125,5
	M56 x 5,5	PGTD5685S	85	1350	12.942	1747,1	10,0	132	142	65	346	112	3/8	30,0	117	132,5
	M60 x 5,5	PGTD6090S	90	1350	15.032	2029,3	10,0	141	152	70,5	372	115	3/8	37,2	125	143
	M64 x 6,0	PGTD6495S	95	1350	17.123	2311,6	10,0	151	159	76	386	119	1/2	43,0	133	152,5
	M68 x 6,0	PGTD68100S	100	1350	19.514	2634,4	10,0	160	170	80	398	123	1/2	49,5	138	160
M72 x 6,0	PGTD72105S	105	1350	21.977	2966,9	10,0	171	177	88,5	429	126	1/2	60,1	146	171	

* Dimension S = Square Drive of Puller Bar and Gear Box.

▼ FTR-Series, Foundation Bolt Tensioners Round



- **FTR-Series Foundation Bolt Tensioners provide fast, accurate and easy tightening of external or internal-ring wind tower foundations**
- **Standard models are available for 75, 150 ksi and metric style Williams, Dyson and Macalloy® bar types**
- **Long-stroke options accelerate process with single-pull tensioning.**

High Precision, Low Maintenance



FTR-Series Foundation Bolt Tensioners

FTR-Series Foundation Bolt Tensioners are designed specifically for tensioning wind tower foundation bolts. These tensioners provide the speed and precision required by this critical application. Potential thread fit problems are eliminated through the use of existing rebar hex nuts as a reaction point.

The FTR-Series includes long-stroke models, which provide greater speed and ease of use by enabling applications to be completed in a single pull.

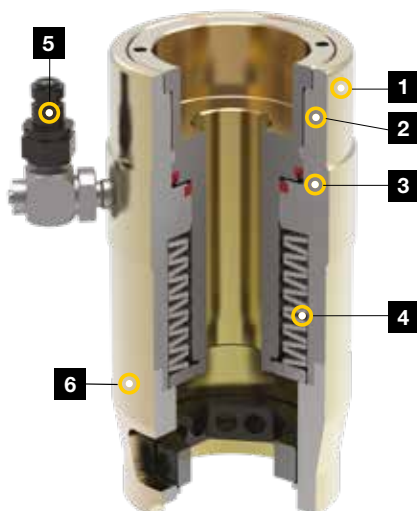

1. **Corrosion protection:** Zinc coating provides best-in-class corrosion resistance.
2. **Over-stroke indicator:** Extends life by helping to prevent over-stroking of cylinder.
3. **Long-life seals:** For maximum durability and extended service life intervals.
4. **Auto-retract piston:** Simplifies use and improves speed of operation.
5. **Quick-disconnect coupler:** For safe, simple hydraulic connection. Optional 360° swivel available for additional hose positioning flexibility.
6. **Interchangeable bridge:** For optimal application fit.

▼ *FTR-Series Foundation Bolt Tensioner. Manual wrench (not included) required to apply up to 30 Nm of torque during installation of models that feature run down gears.*



Foundation Bolt Tensioners

▼ This is how a FTR-Series Foundation Bolt Tensioner model number is built up:



1 Product Type

FTR = Foundation Tensioner, Round

2 Bar Grade

75 = 75 ksi
150 = 150 ksi
 (or metric designation)

3 Bar Size Designation

Example
14 = No. 14 bar size

4 Maximum Stroke

Example:
20 = 20 mm max. stroke

5 Fitting Type

SW = Includes swivel manifold with single male fitting

6 Run Down Gear

G = Includes Nut Run Down Gear
 * available in select models

FTR Series



Maximum Load Capacity:

2736 kN

Maximum Operating Pressure ¹⁾:

1500 bar

¹⁾ Max. pressure varies, see specifications table for details.



Tensioning Pumps

Electric, pneumatic and manual high-pressure tensioning pumps are available for use with Enerpac hydraulic tensioners.

Page: **219**



Hoses and Fittings

High-pressure hoses and fittings for use with Enerpac tensioning systems are available.

Page: **309**



Bolting Integrity Software

The software offers Tool selection, Bolt Load calculations and Tool pressure settings, as well as, a combined Application data sheet and Joint completion report. Custom Joint information can also be entered.

Page: **422**

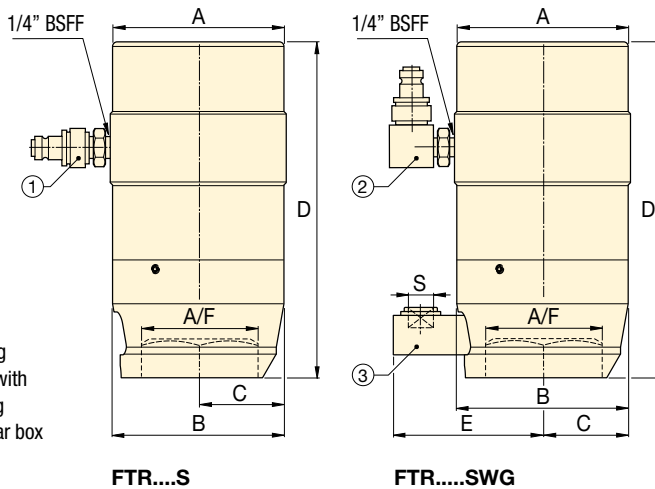

- ① Single male fitting
- ② Swivel manifold with single male fitting
- ③ Nut run down gear box

FTR...S

FTR.....SWG

▼ SPECIFICATION TABLE

Bar Grade	Bolt Diameter		Bar Size Designation	Model Number with single male fitting	Nut Size A/F	Max. Pressure	Hydraulic Pressure Area	Max. Load Capacity	Stroke	Dimensions (mm)					Minimum Bolt Potrusion	
	(mm)	(inch)								A	B	C	D	E		(kg)
75 ksi	35	1.38	#10	FTR751010S	51	1200	3134	376,1	10,0	99	88,5	44,3	163	–	5,8	200
	35	1.38	#10	FTR751025S	51	1200	3123	374,8	25,0	115	102	42	220	–	10,9	250
	38	1.50	#11	FTR751110S	57	1500	3134	470,1	10,0	99	98	38	178	–	5,5	220
	38	1.50	#11	FTR751125SG	57	1500	3123	468,5	25,0	115	102	51	226	96	11,5	260
	48	1.88	#14	FTR751420S	70	1170	6093	712,9	20,0	132	132	66	268	–	18,2	315
150 ksi	37	1.44	1.25	FTR15012510S	57	1170	5383	629,8	10,0	111	110	40	178	–	8,2	220
	40	1.56	1.37	FTR15013810S	64	1500	5383	807,5	10,0	111	110	38	178	–	8,1	225
	70	2.75	2.50	FTR15025025S	108	1500	18.238	2736,0	25,4	215	212	86	348	–	58,0	450
10.9	36	1.42	36	FTR1093610SG	60	1500	3820	573,0	10,0	102	99	40	176	95	8,6	195

Gear box square drive dimension S = 1/2 inch.

▼ FTE-Series, Foundation Bolt Tensioner Elliptical



- **FTE-Series Foundation Bolt Tensioners provide fast and accurate performance in difficult, narrow access foundation tensioning applications**
- **Standard models are available for 75, 150 ksi and metric style Williams, Dyson and Macalloy® bar types**
- **Ideal universal solution that fits both standard and narrow access applications.**

High Precision, Low Maintenance



FTE-Series, Foundation Bolt Tensioners

Similar to Standard Foundation Tensioners, Elliptical tensioners were designed specifically for foundation fastening applications on wind towers, and utilize the existing hex nut as a reaction point in order to eliminate thread fit misalignment.

Unlike standard FTR-Series Tensioners, the FTE-Series Tensioners feature an elliptical geometry, which enables fit in narrow access foundation applications, without reducing load capabilities.

Operators may access the nut with a Tommy bar rather than employing the use of an offset rundown gear.

Elliptical tensioners are ideal for close clearance applications, or as a universal tool that will work in nearly any foundation application, whether standard or narrow access.

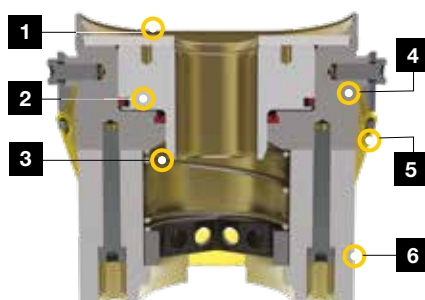

1. **Maximum stroke Indicator:** Extends life by helping to prevent over-stroking of cylinder.
2. **Long-life seals:** For maximum durability and extended service life intervals.
3. **Auto-retract piston:** Simplifies use and improves speed of operation.
4. **Elliptical form:** Provides access to close clearance applications.
5. **Corrosion protection:** Zinc coating provides best-in-class corrosion resistance.
6. **Quick-disconnect coupler:** (*not shown*) For safe, simple hydraulic connection. Optional 360° swivel available for additional hose positioning flexibility.

▼ *FTE-Series, Foundation Bolt Tensioner, designed to fit both standard and narrow access foundation applications.*



Foundation Bolt Tensioners, Elliptical

▼ This is how a FTE-Series Foundation Bolt Tensioner model number is built up:



1 Product Type

FTE = Foundation Tensioner, Elliptical

2 Bar Grade

75 = 75 ksi
150 = 150 ksi
 (or metric designation)

3 Bar Size Designation

Example
10 = No. 10 bar size

4 Fitting Type

SW = Includes swivel manifold with single male fitting

FTE Series



Maximum Load Capacity:

761,1 kN

Maximum Operating Pressure ¹⁾:

1500 bar

¹⁾ Max. pressure varies, see specifications table for details.



Tensioning Pumps

Electric, pneumatic and manual high-pressure tensioning pumps are available for use with Enerpac hydraulic tensioners.

Page: 219



Hoses and Fittings

High-pressure hoses and fittings for use with Enerpac tensioning systems are available.

Page: 309



Bolting Integrity Software

The software offers Tool selection, Bolt Load calculations and Tool pressure settings, as well as, a combined Application data sheet and Joint completion report. Custom Joint information can also be entered.

Page: 422

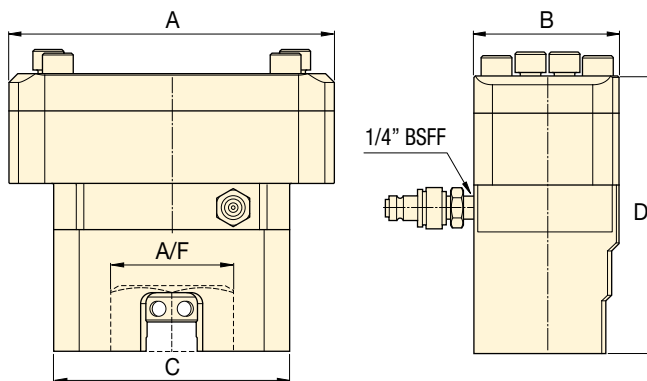

▼ SPECIFICATION TABLE

Bar Grade	Bolt Diameter		Bar Size Designation	Model Number with single male fitting	Nut Size A/F	Max. Pressure	Hydraulic Pressure Area	Max. Load Capacity	Stroke	Dimensions (mm)				Minimum Bolt Potrusion	
	(mm)	(inch)								A	B	C	D		
75 ksi	35	1.38	#10	FTE7510S	51	1200	3108	373,0	10,0	170	82	142	147,5	8,3	200
	38	1.50	#11	FTE7511S	57	1500	3108	466,2	10,0	170	82	142	147,5	8,3	200
150 ksi	40	1.56	1.375	FTE150138S	64	1500	5074	761,1	10,0	222	99	161	203,4	18,5	230
	37	1.44	1.250	FTE150125S	57	1200	5074	608,9	10,0	222	99	161	203,4	18,9	240
8.8	36	1.42	36	FTE8836S	60	1500	3108	466,2	10,0	142	82	142	147,5	9,7	180

▼ HPT1500



HPT Series

Reservoir Capacity:

2,5 litres

Flow at Rated Pressure:

0,61 cm³/stroke

Maximum Operating Pressure:

1500 bar



Applications

The hand pump is ideally suited for use with hydraulic bolt tensioning tools and hydraulic nuts.

Page: 294

- Lightweight and portable high-pressure hand pump
- Two-speed operation displaces a larger volume of oil per stroke, reducing cycle times for many testing applications
- Includes a pressure gauge and coupler for direct connection to Enerpac Bolt Tensioners
- Integrated relief valve set at 1500 bar.



Ultra-high pressure

This pump operates at ultra-high pressure, use only the specified fittings and hoses designed for these pressures.

Page: 309



Bolt Tensioning Theory

See more on tensioning operation and procedures in our "Yellow Pages".

Page: 420



Bolting Integrity Software

The software offers Tool selection, Bolt Load calculations and Tool pressure settings, as well as, a combined Application data sheet and Joint completion report. Custom Joint information can also be entered.

Page: 422

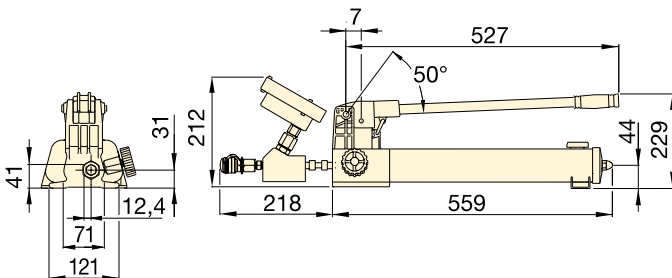

1500 BAR ULTRA-HIGH PRESSURE PUMP

Pump Type	Useable Oil Capacity (litres)	Model Number	Pressure Rating (bar)		Oil Displacement per Stroke (cm ³)		High Pressure Oil Port with female coupler	(kg)
			1st stage	2nd stage	1st stage	2nd stage		
Two Speed	2,54	HPT1500	14	1500	16,22	0,61	1/4" BSPP + BR-150	9,0

Ultra-High Pressure Hoses & Couplers

- **Hose Reel and Stand:** Stainless steel stand with 1500 bar hoses from 30 upto 270 metres lengths
- All hose reels are built up with multiple 30 metres length hoses
- Wide offering of hoses and system components to complete your tensioning system
- Can be used for subsea fastening systems
- Hoses can be inter-connected in multi-tool set-ups using nipples, couplers, T-pieces and Y-Pipe assemblies.

HT, B Series



Hose Lengths:

1 - 30 metres

Hose Reel & Stand:

30 - 270 metres

Maximum Operating Pressure:

1500 bar

1500 BAR HOSE REEL & STANDS

Model Number		Stainless Steel Hose Reels with Stand (Hose with Female Half BR150 and Male Half BH150 couplers)
HT1500RS		Reel & Stand Assembly, No Fittings
HT1500HRS		Hose Reel & Stand, No Hose
HT1510HRS		Hose Reel & Stand, with 30 m hose
HT1520HRS		Hose Reel & Stand, with 60 m hose
HT1530HRS		Hose Reel & Stand, with 90 m hose
HT1540HRS		Hose Reel & Stand, with 120 m hose
HT1550HRS		Hose Reel & Stand, with 150 m hose
HT1560HRS		Hose Reel & Stand, with 180 m hose
HT1570HRS		Hose Reel & Stand, with 210 m hose
HT1590HRS		Hose Reel & Stand, with 270 m hose



▲ Inter-connected with HT-Series hoses Enerpac subsea tensioners apply uniform bolt load.

1500 BAR HOSES

Model Number		Hose End 1	Hose End 2	Length (m)
HT1503		1/4" BSPM 120° Cone	1/4" BSPM 120° Cone	1,0
HT1510		1/4" BSPM 120° Cone	1/4" BSPM 120° Cone	3,0
HT15100		1/4" BSPM 120° Cone	1/4" BSPM 120° Cone	30,0
HT1503HR *		BH150	BR150	1,0
HT1506HR *		BH150	BR150	1,8
HT1510HR *		BH150	BR150	3,0
HT1520HR *		BH150	BR150	6,1
HT15100HR *		BH150	BR150	30,0
HT1503RR *		BR150	BR150	1,0
HT1506RR *		BR150	BR150	1,8
HT1510RR *		BR150	BR150	3,0
HT1520RR *		BR150	BR150	6,1

* Includes dust caps.

H = Male Nipple (BH150); R = Female Coupling (BR150)

1500 BAR COUPLERS

Description (includes dust caps)		Complete Set	Female Half	Male Half
Quick Disconnect Coupler		B150	BR150	BH150
Quick Disconnect Coupler & Adaptor Kit		BW150AW	-	-
Quick Disconnect Blanking Coupler Set		B150B	BR150B	BH150B

1500 BAR T-PIECES

Model Number	shown HT15TPMMF	End 1	End 2	End 3
HT15TPMMF		1x BH150	1x BH150	1x BR150
HT15TPMMM		1x BH150	1x BH150	1x BH150

1500 BAR Y-PIPE ASSEMBLIES

Model Number	shown HT1506YTPMMF	End 1 Hose	End 2 Hose	End 3 T-Piece
HT1506YTPMMF		HT1506HR	HT1506HR	HT15TPMMF
HT1510YTPMMF		HT1510HR	HT1510HR	HT15TPMMF
HT1506YTPFMF		HT1506RR	HT1506RR	HT15TPMMM
HT1510YTPFMF		HT1510RR	HT1510RR	HT15TPMMM

Y-Pipe Assembly: 1+2 = adaptor; 3 = stainless steel T with 1/4" BSPM
4 = Male Nipple (BH150); 5 = Female Coupling (BR150); 6 = Hose

▼ ZUTP1500SE-H



- Solenoid-operated valve with 6 m pendant for remote control of valve and one-man operation
- Easily accessible manual override valve to release pressure if power is lost
- Safety relief valve limits output pressure
- Two-stage pump design provides high flow at low pressure for fast system fills and controlled flow at high pressure for accurate operation
- 1,25 kW heavy-duty universal motor provides the best performance-to-weight ratio
- Replaceable 10 micron reservoir breather and inline high pressure filter helps maintain oil cleanliness for optimum performance
- Panel-mounted 153 mm pressure gauge, with polycarbonate cover, is set into the protective metal shroud for improved visibility.

ZUTP Series

Reservoir Capacity:

4,0 litres

Flow at Rated Pressure:

0,33 l/min

Motor Size:

1,25 kW

Maximum Operating Pressure:

1500 bar



ZUTP-Tensioning Pumps

ZUTP-pumps achieve high pressure without the need for an intensifier.

This allows for low maintenance, resulting in less cost for the end-user.

ZUTP-S with Solenoid Valve

The ZUTP1500S with pendant-operated solenoid valve is ideal for multiple bolt tensioning applications as it allows for single-person operation. The operator can pressurize and depressurize the tensioner directly from the pendant.

OIL FLOW VERSUS PRESSURE

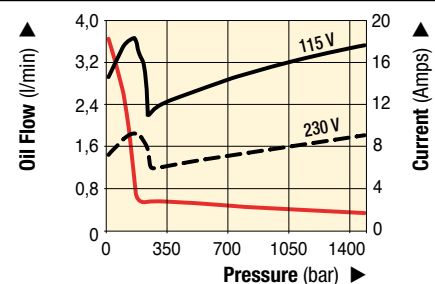

1500 bar HIGH PRESSURE PUMP

Useable Oil Capacity (litres)	Valve Type	Model Number ¹⁾	Pressure Rating (bar)	Output Flow Rate (l/min)		1,25 kW Motor ⁵⁾ (VAC, 1-ph, 50 Hz)	Weight (kg)
				0 bar	1500 bar		
4,0	Solenoid	ZUTP1500SB	1500	3,80	0,33	115	29,5
		ZUTP1500SE ²⁾				230 ²⁾	
		ZUTP1500SI ³⁾				230 ³⁾	
4,0	Solenoid	ZUTP1500SB-H ⁴⁾	1500	3,80	0,33	115	34,0
		ZUTP1500SE-H ^{2) 4)}				230 ²⁾	
		ZUTP1500SI-H ^{3) 4)}				230 ³⁾	
4,0	Jog	ZUTP1500B	1500	3,80	0,33	115	29,5
		ZUTP1500E ²⁾				230 ²⁾	
		ZUTP1500I ³⁾				230 ³⁾	

¹⁾ All models meet CE safety requirements and all TÜV requirements.
²⁾ European plug and CE EMC directive compliant.
³⁾ With NEMA 6-15 plug. ⁴⁾ H = with heat exchanger.
⁵⁾ Sound level 89 dBA.

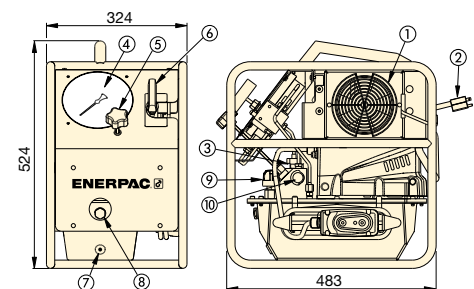

- ① Heat Exchanger (optional)
- ② Power Cord
- ③ Solenoid Dump Valve
- ④ Pressure Gauge
- ⑤ User Adjustable Relief Valve
- ⑥ Manual Release Valve
- ⑦ Oil Drain
- ⑧ Oil Level Sight Glass
- ⑨ Breather
- ⑩ Outlet Port with CEJN Coupler (116 Series)

Ultra-High Pressure Air Pump

▼ ATP1500



- General purpose, high pressure air driven two speed pump unit for products requiring up to 1500 bar hydraulic pressure
- Compact, lightweight, rugged steel frame for protection and easy handling
- Prelubricated pump element, does not require an airline lubricator
- Easily adjustable output pressure control
- Integrated and protected easy to read glycerin filled gauge
- Safety relief valve limits output pressure.

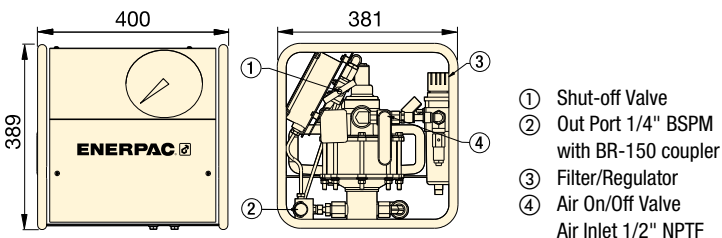

1500 bar HIGH PRESSURE AIR PUMP

Pump Type	Useable Oil Capacity (litres)	Pressure Rating (bar)	Model Number	Output Flow Rate at 0 bar (l/min)	Output Flow Rate at 1500 bar (l/min)	Air Pressure Range (bar)	Air Consumption (l/min)	Sound Level (dBA)	 (kg)
Two speed	3,8	1500	ATP1500	0,43	0,07	5,5 - 6,2	594	70	32

ATP Series

Reservoir Capacity:
3,8 litres

Flow at Rated Pressure:
0,07 l/min

Maximum Operating Pressure:
1500 bar



Ultra-high pressure

This pump operates at ultra-high pressure, use only the specified fittings and hoses designed for these pressures.

Page: 309



Applications

The ATP-pump is ideally suited for use with hydraulic bolt tensioning tools and hydraulic nuts.



ATEX Certified

The ATP-Pump is tested and certified according ATEX.

 II 2 GD ck T4

Page: 405

OIL FLOW VERSUS PRESSURE

Flow (l/min) at 6,2 bar air input

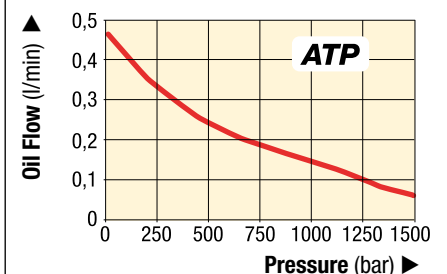

Tensioning every single stud in a joint simultaneously



▲ *Multi Stud Tensioning Set-Up.*

MULTI STUD TENSIONERS

Enerpac Multi Stud Tensioning (MST) systems are capable of tensioning every single stud in a joint simultaneously. By applying a predictable and accurate pre-load to all studs, problems associated with conventional bolt tightening techniques are avoided. Typical Enerpac Multi Stud Tensioning applications include:

Manway, Hand Hole & Inspection Covers

MST systems are the fastest and most accurate means of loosening and tightening studs on Primary & Secondary Manway Covers, Hand-Hole and Inspection Ports in nuclear facilities. Using special ram areas and strong lightweight materials, the MST's reduce bolting time by as much as 75%.

Coolant Pump

A custom slimline tensioning system for a Nuclear Reactor Coolant Pump, using six equally spaced tensioners and tightening studs in four passes, has reduced bolting times by 25% and significantly increased tensioning accuracy.

Wind Turbine Blade Assembly

Using an Enerpac MST has allowed wind turbine blade assembly times to be reduced by approx. 65% while bolt load accuracy and consistency have improved, resulting in better joint life and reduced maintenance requirements. The MST, comprising four tool segments, is capable of simultaneously tensioning up to 88 bolts connecting a 125 ft long blade to a bearing slew ring.

MST - Multi Stud Tensioners

This tool can be custom-designed, and built, for virtually any nuclear facility. We specialise in addressing difficult projects that demand accurate loads within tight space envelopes, while also seeking ease of operation and performance.

- Designed in segments enabling the operator to easily and quickly connect each segment to the joint and link together to provide simultaneous loading.
- Very accurate and fast closure system for large tensioning applications on pumps, valves, and steam-generators, for example.
- For ease of handling on-site, Enerpac MST systems can be supplied with an integral lifting frame and trolley.



▲ *Multi Stud Tensioner.*



▲ *Multi Stud Tensioning application.*

A simple and effective method of tensioning large bolts in difficult to access areas



▲ Tensioning with hydraulic nuts.

HYDRAULIC NUTS

Enerpac hydraulic nuts (HN) are used in many process-critical bolting applications where the ease of installation and manpower time savings are substantial and on-going. Moreover, they eliminate many of the uncertainties of torque arising from friction, point loading and load scatter.

Enerpac Hydraulic Nuts are a simple and effective method of tensioning large bolts in difficult to access areas with insufficient space for standard tensioners. Typically used when installing and maintaining bolting systems, hydraulic nuts can replace both conventional hexagon nuts and standard round nuts providing a high and predictable degree of tensioning accuracy.

Threaded directly onto the stud, Enerpac hydraulic nuts apply a direct axial elongation by means of hydraulic force generated via the nut's integral hydraulic cylinder. The nut is held in place either by means of a top or bottom load retaining collar externally located on the nut or by the insertion of mechanical shims. Enerpac hydraulic nuts can be retrofitted to existing plant providing an accurate solution to mechanical jointing problems.

Benefits of Enerpac Hydraulic Nuts

- Highly Accurate & Repeatable Bolt Loads
- Ideal where space limitations prevent use of standard detachable tensioners
- Direct Axial Loading - No nut rotation required
- Multiple Nuts can be connected and tightened / loosened simultaneously
- Eliminates issues with friction
- Substantial time savings due to the quick set-up and hydraulic nuts remaining in-situ
- No stud or flange damage (Galling, Seizure)
- No need to change joint hardware – system works with existing studs
- Ideal when the tension in bolts needs to be checked regularly such as vibration loosening.

Enerpac hydraulic nut (HN) applications have included:

The Hydraulic Nut is a permanent fixture, replacing the conventional nut and retaining the high bolt load and extension in small space envelopes where there may not be sufficient space to use tensioners.

- Flange Clamps: Pipeline, Structural
- Turbines: Gas, Wind, Steam
- Pressure & Reactor Vessels
- Diesel Engines
- Nuclear Applications: Steam Generators
- Hydraulic and Mechanical Presses
- Heat Exchangers
- Pipeline Flanges, Valves and Control Systems
- Valves & Pumps
- Cranes – Slew Ring Bolts, Tower Cranes
- Shaft Couplings
- Mining: Grinders, Cutters, Earth Moving Equipment.



▲ Hydraulic nuts on a diesel engine.

▼ From left to right: **ATM4, ATM9, ATM2** (ATM9 shown without pump and hose)



- Enerpac ATM-Series tools rectify twist and rotational misalignment quickly, safely and without the need for an external power source
- Appropriate for use on most ANSI, API, BS and DIN flanges
- Reduces set-up time: no need for chains, pulleys or rigs
- Safety strap helps provide secure operation
- Can be installed and used in any position
- Stays stable in position under full load
- Portable, lightweight design enables easy transport and use, even in remote locations
- Each ATM-model contains a tool and kit box.

▼ The compact ATM2 is actuated by simply hand turning the crank.



The faster, simpler and safer way to align flanges



Adjustable Reach

The highly adjustable reach of the wing and drop leg on ATM4 and ATM9 allow precise alignment.



Gauge and Adaptor

The ATM9 includes P142 hand pump and HC7206C 1,8 m long hose. Enerpac recommend the use of the pressure gauge GP10S and gauge adaptor GA4 for easy mounting of the gauge onto your system or use GA456C Gauge Adaptor Assembly.

Page: 127



TFA-Series Wind Turbine Tower Flange Alignment Tools

The TFA-Series Wind Turbine Tower Flange Alignment Tools have been developed to aid the alignment of large flanges on the inside of wind turbine towers during their assembly or installation.

Page: 340

▼ The ATM9 is shown here with optional pressure gauge and gauge adaptor.





Applications

Enerpac ATM-Series Tools help correct flange misalignment, and allow bolts to be placed into joints. This alignment takes place during pipework construction, or maintenance.

These tools provide pipe installers and maintenance personnel with some of the simplest, safest and most productive solutions available for flange alignment in the market today.

- ① Extendable wing provides usage on wide variety of flanges.
- ② Portable, light weight design enables easy transport and use.
- ③ Hand-adjustable base for easy positioning by a single operator.
- ④ Safety strap helps provide secure operation from a horizontal or vertical position.

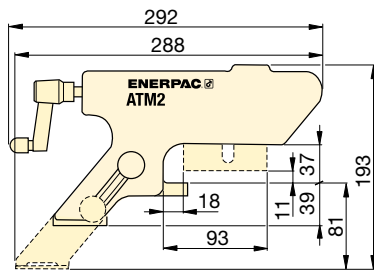
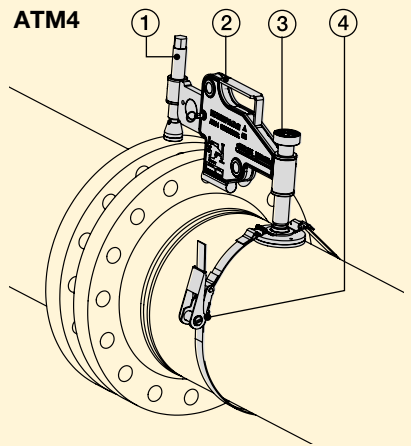

ATM2

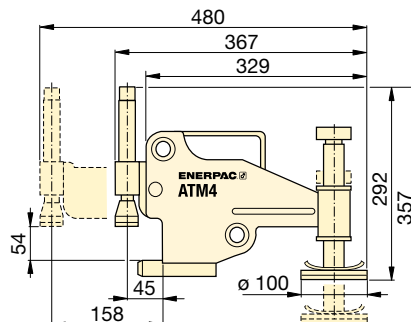

ATM4

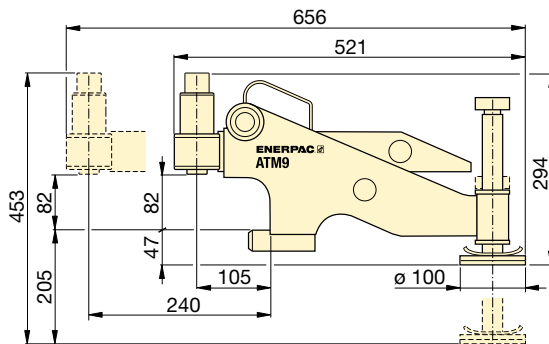

ATM9

Maximum Lifting Force		Model Number	Minimum Bolt Size		Flange Wall Thickness		Weight (kg)
(ton)	(kN)		(mm)	(inch)	(mm)	(inch)	
1	10	ATM2	16	.63	14 - 82	.55 - 3.29	1,6
4	40	ATM4	24	.95	30 - 133	1.18 - 5.23	8,6
9	90	ATM9 *	35,5	1.40	93 - 228	3.66 - 9.00	14,5

* ATM9 includes an Enerpac hand pump and hydraulic hose (gauge and adaptor sold separately). ATM9 weight includes tool only.

ATM Series



Minimum Bolt Size:

16 - 35,5 mm

Flange Wall Thickness:

14 - 228 mm

Maximum Lifting Force:

1 - 9 ton (10 - 90 kN)



Cylinder-Pump Sets

Hydraulic cylinders, jacks and lifting wedges can also be used to assist in pipe line positioning and aligning.

Page: 62



Pipe Flange Face Tool

The portable, hand powered tool FF120 makes even the hardest to reach pipe flanges resurfaceable in a safe and convenient way.

Page: 324

▼ The ATM-Series – the faster, simpler and safer way to align flanges.



▼ FSC14, FSM8 and FSH14 with safety blocks SB1



- **Unique interlocking wedge design** no first step bending and risk of slipping out of joint
- **Requires very small access gap** of only 6 mm
- **Few moving parts** mean durability and low maintenance
- **Safety block SB1** included with FSC14, FSH14 and FSM8
- **Ratchet spanner SW22** included with FSM8 mechanical spreader
- **Singleacting cylinder** included with FSH14 hydraulic spreader.

▼ Two FSH14 spreaders used simultaneously with Enerpac handpump, hoses and AM21 control manifold.



Practical, portable and lightweight



FSC14 with integrated hand pump

Powered by a builtin hydraulic hand pump, the FSC14 is a readytouse tool – no making or breaking hydraulic connections. This compact tool delivers 14 US tons of force and requires a clearance gap as small as 6 mm.



Stepped Blocks FSB1

Use stepped blocks to increase wedge opening up to 80 mm. Fits both FSC, FSH and FSM models.



AM-Series Control Manifolds

For simultaneously and even spreading of flange joints, 180° apart with FSH14.

Page: 132



Flange Maintenance Tools

Secure-Grip and Zero-Gap flange spreading tools for application on flanges with a zero or small gap.

Page: 327

Flange Spreading Wedges



Flange Spreading Wedges

The flange spreading tools have been developed to aid and simplify the maintenance of flange joints. No longer will those tasked with separating flanges have to rely on using ropes and pulleys, podgers, tiffors, come-alongs or hammers – there is a safe, quick and effective alternative, the Enerpac range of spreaders.

These spreaders use mechanical and hydraulic principles for separating flanges and can spread small, medium or large flange joints. Tool selection is made on the basis of the access gap between the flange faces, the flange size and the required scope of work.

FSC, FSH, FSM Series



Tip Clearance / Maximum Spread ¹⁾:

6 mm / 80 mm

Maximum Spread Force:

8 - 14 US tons

Maximum Operating Pressure:

700 bar (FSH14)

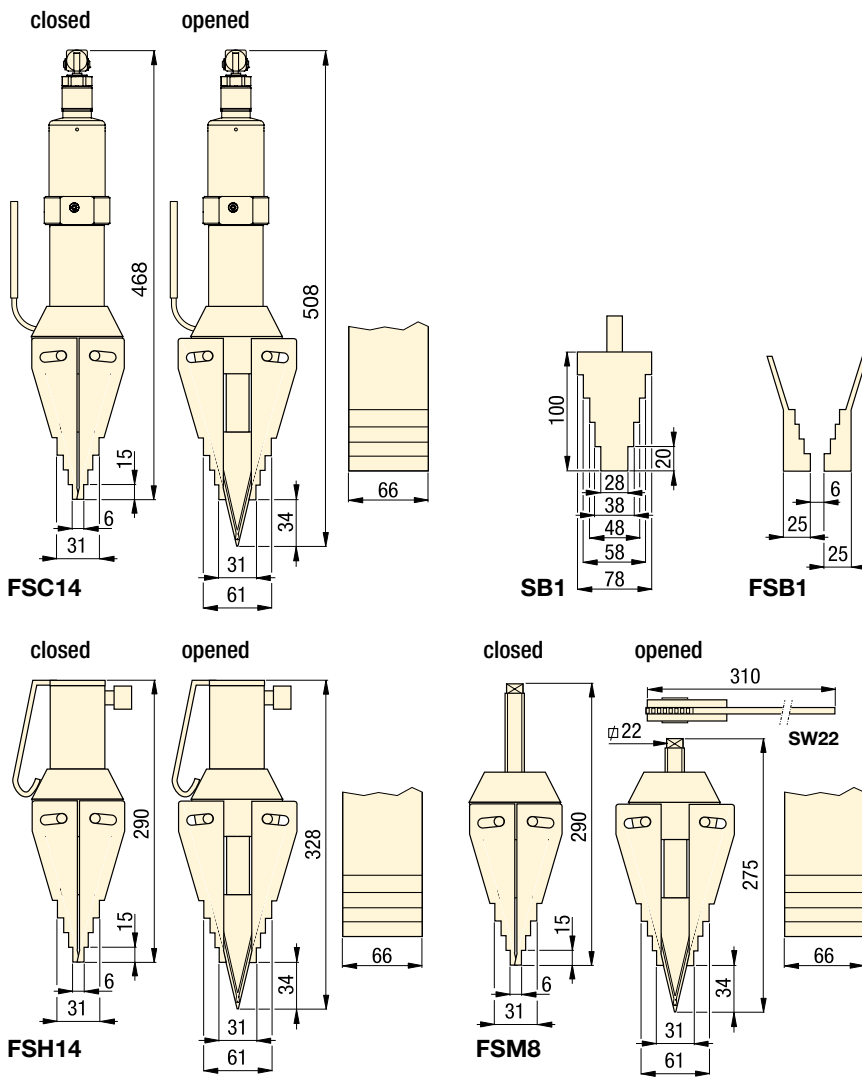

Safety Lanyard FSC1

Recommended safety accessory to compliment bolting applications. Includes steel cable with carabiners.

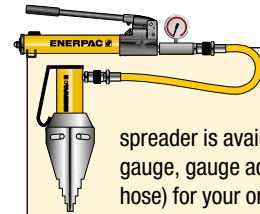

Tool-Pump Sets

The hydraulic flange spreader is available as set (pump, tool, gauge, gauge adaptor, couplers and hose) for your ordering convenience.

Spreader Model Nr.	Handpump Model Nr.	Set Model Number
FSH14	P392	STF14H

▼ Flange maintenance and joint separation with FSH14 Hydraulic Wedge Spreader.



Maximum Spreading Force US tons (kN)	Model Number	Tip Clearance (mm)	Maximum Spread ¹⁾ (mm)	Spreader Type	Oil Capacity (cm ³)	Weight (kg)
14 (118)	FSC14	6	80	Integral hydraulics	–	9,0
14 (125)	FSH14 *	6	80	External hydraulics	78	7,1
8 (72)	FSM8	6	80	Mechanical	–	6,5

¹⁾ Using stepped blocks FSB1.

* Available as pump-tool set, see note on this page.

▼ Shown from left to right: NC3241, NC1019, NC1924



- Compact and ergonomic design, easy to use
- Unique angled head design
- Two blade design (NC-D models) for time saving operation – nuts are split from two sides in one action
- Single-acting, spring return cylinder
- Heavy duty chisels can be reground
- Nut splitters include spare chisel, spare set screw and wrench used to secure the chisel.
- CR400 female half coupler is standard.

The safest and easiest way to remove corroded and frozen nuts

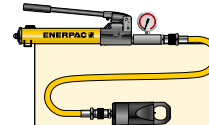

Tool-Pump Sets

Hydraulic Nut Splitters are available as sets (pump, tool, gauge, gauge adaptor, couplers and hose) for your ordering convenience.

Nut Splitter Model Nr.	Hand Pump Model Nr.	Nut Splitter Set Model Number
NC1924	P392	STN1924H
NC2432	P392	STN2432H
NC3241	P392	STN3241H



High Pressure Hoses

Enerpac offers a complete line of high quality hydraulic hoses. To ensure the integrity of your system, specify only genuine Enerpac hydraulic hoses.

Page: 128

▼ Enerpac hydraulic nut splitters – the safest and easiest way to remove corroded and frozen nuts.



GA45GC Gauge Adaptor Assembly

Protect yourself from system overloading by simply ordering one part number for a pre-assembled gauge, adaptor block and coupler.

Page: 142

Single-Acting Hydraulic Nut Splitters



Frozen or Corroded Nuts

Often nuts are difficult to remove, while loosening using tightening tools is possible, it generally requires larger equipment and is time consuming. The use of cutting torches or hammers and chisels can cause damage to the joint components, requires significantly longer setup and operational time, and can present a potential safety risk.

Hydraulic Nut Splitters

Nut splitting with the Enerpac Hydraulic Nut Splitters is the safest method. It takes less time and avoids costly damage to joint components. The head design fitted with heavy-duty chisels permits the splitting of nuts on a wide variety of applications. With the two blades models nuts are split from two side in one action.

NC STN Series



Bolt Range:
M6 - M48

Hexagon Nut Range:
10 - 75 mm

Capacity:
49 - 882 kN

Maximum Operating Pressure:
700 bar

For Nut Splitter Model Nr.	Replacement Chisel Model Numbers	
	Moving	Static
NC1019	NCB1019	-
NC1924	NCB1924	-
NC2432	NCB2432	-
NC3241	NCB3241	-
NC4150	NCB4150	-
NC5060	NCB5060	-
NC6075	NCB6075	-
NC1924D	NCB1924	NCB1924D
NC2432D	NCB2432	NCB2432D
NC3241D	NCB3241	NCB3241D

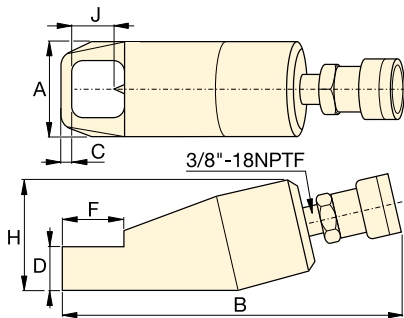

Single Blade Models (NC)

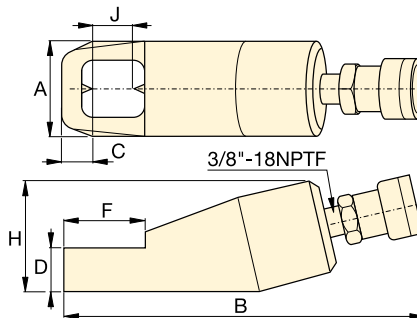

Double Blade Models (NC-D)



Bolt Range (mm)	Hexagon Nut Range (mm)	Maximum Cutting Force ton (kN)	Oil Capacity (cm ³)	Model Number	Dimensions (mm)							Weight (kg)	
					A	B	C	D	F	H	J		
	M6 - M12	10 - 19	5 (49)	15	NC1019	40	170	7	19	28	48	21	1,2
	M12 - M16	19 - 24	10 (98)	20	NC1924 *	54	191	10	26	40	62	25	2,0
	M16 - M22	24 - 32	15 (147)	60	NC2432 *	64	222	13	29	51	72	33	3,0
	M22 - M27	32 - 41	20 (196)	80	NC3241 *	75	244	17	36	66	88	43	4,4
	M27 - M33	41 - 50	35 (343)	155	NC4150	94	288	21	45	74	105	54	8,2
	M33 - M39	50 - 60	50 (490)	240	NC5060	106	318	23	54	90	128	60	11,8
	M39 - M48	60 - 75	90 (882)	492	NC6075	156	393	26	72	110	181	80	34,1
	M12 - M16	19 - 24	10 (98)	20	NC1924D	54	168	22	25	50	66	26	3,8
	M16 - M22	24 - 32	15 (147)	60	NC2432D	64	275	25	31	65	78	33	5,4
	M22 - M27	32 - 41	20 (196)	80	NC3241D	77	305	31	37	80	90	43	7,2

Ordering Notes: Maximum allowable hardness to split is 44HRc. Not to be used on square nuts or stainless steel.

* Available as Tool-Pump Set, see note on page 318.

▼ Shown from left to right: NSH1927, NSC1927



- NSC-Series with built-in small hand pump – useful for subsea applications and working at heights
- Quick and easy cutting tip replacement
- Drop-tested revolving anchor point and safety lanyard
- Revolving composite handle for vibration and shock isolation
- Nut Splitters include set of hexagon keys and following spare parts:
 - cutting tip,
 - tip retention screw,
 - spare alignment screw
- CR400 female half coupler is standard (NSH).

▼ *The sharp cutting tip and opposing convex reaction point encourages more efficient splitting by spreading the nut open rather than squashing the nut onto the stud. This makes it easier to rotate the nut for the second cut.*

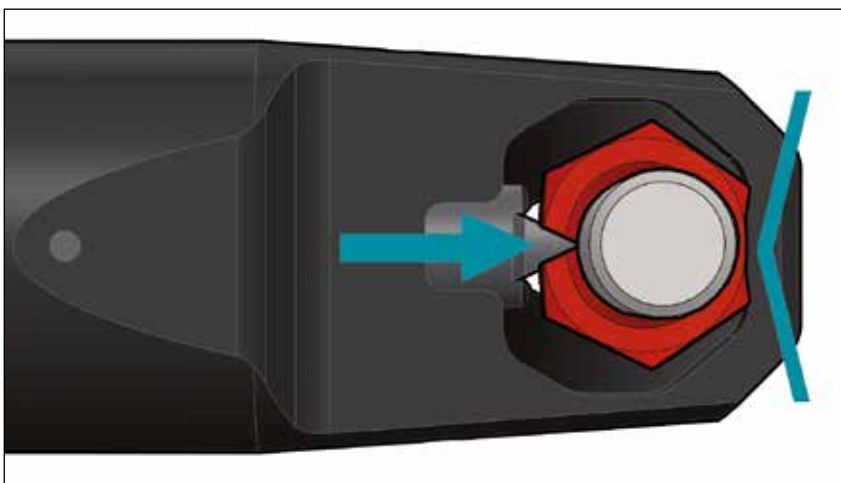

Designed to meet the challenges of bolted pipe-line flange joints



NSC-Series Nut Splitters with integral hand pump

Powered by a built-in hydraulic hand pump, the NSC-Series are a ready-to-use tool – no need for hose, separate hand pump or couplings.



Carry Case

Nut splitters (up to NSH6575) come in a carry case for portability and easy storage.



Safety Lanyard FSC1

Standard Safety Lanyard with each nut splitter. Includes steel cable with carabiners.



Single-Acting Integral & Hydraulic Nut Splitters



Frozen or Corroded Nuts

Often nuts are difficult to remove, while loosening using tightening tools is possible, it generally requires larger equipment and is time consuming.

The use of cutting torches or hammers and chisels can cause damage to the joint components, requires significantly longer setup and operational time, and can present a potential safety risk.

Hydraulic Nut Splitters

Nut splitting with the Enerpac Hydraulic Nut Splitters is the safest method. It takes less time and avoids costly damage to joint components. The head design fitted with heavy-duty chisels permits the splitting of nuts on a wide variety of applications.

NSC NSH Series



Bolt Range:

M12 - M48

Hexagon Nut Range:

19 - 75 mm

Capacity:

120 - 500 kN (12 - 50 ton)

Maximum Operating Pressure:

700 bar (NSH-Series)

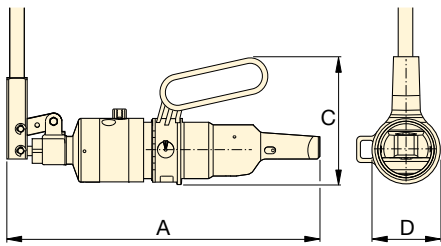

NSC

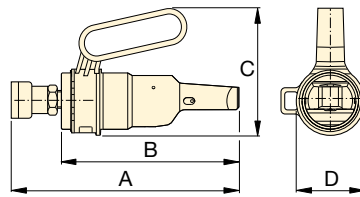

NSH

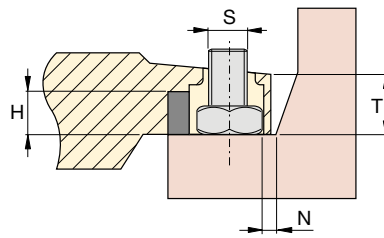
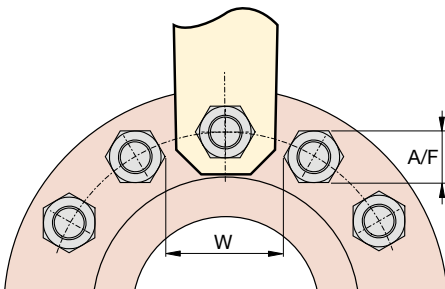

High Pressure Hoses

Enerpac offers a complete line of high quality hydraulic hoses. To ensure the integrity of your system, specify only genuine Enerpac hydraulic hoses.

Page: 128



Joint Separation Tools

Flange Spreading Wedges (FSC, FSH, FSM-Series) provide quick and easy joint separation using hydraulic or mechanical force.

Page: 316

▼ NUT SPLITTER SPECIFICATIONS

Bolt Range	Hexagon Nut Range	Maximum Cutting Force	Oil Capacity	Model Number	Nut Splitter Type	Dimensions (mm)										Cutting Tip Service Kit Model Nr.
						A	B	C	D	H max.	N min.	S max.	T	W min.	(kg)	
M12 - M18	19 - 27	12 (120)	—	NSC1927	Integral pump	353	—	152	81	18	11,5	24,5	26,5	53,5	5,8	NSH1927CTK
M16 - M22	24 - 32	15 (150)	—	NSC2432	Integral pump	370	—	152	81	25	9,0	26,6	32,0	57,5	6,3	NSH2432CTK
M12 - M18	19 - 27	12 (120)	46	NSH1927	Hydraulic	258	213	152	81	18	11,5	24,5	26,5	53,5	3,5	NSH1927CTK
M16 - M22	24 - 32	15 (150)	46	NSH2432		265	220	152	81	25	9,0	26,5	32,0	57,5	4,0	NSH2432CTK
M24 - M30	36 - 46	20 (200)	80	NSH3646		290	239	169	93	34	16,0	39,0	44,0	83,5	6,9	NSH3646CTK
M33 - M42	50 - 65	36 (360)	230	NSH5065		377	322	210	185	45	23,0	49,5	52,0	108,0	10,9	NSH5065CTK
M42 - M48	65 - 75	50 (500)	328	NSH6575		396	345	220	202	54	27,0	61,0	65,0	135,0	24,5	NSH6575CTK

Ordering Notes: Maximum allowable hardness to split is ASTM A194 Gr 2H. Not to be used on square nuts or stainless steel.

▼ Shown: NSH31 with NSPH3, NSH41 with NSPH4



- Designed to fit standard BS/ANSI flanges
- Blade positioning scale to eliminate bolt damage
- Adjustable cutting depth
- Ergonomically designed and positioned handle
- Interchangeable power heads with cutting blade
- Single-acting spring return power head (NSPH)
- Double-acting power head (NSPH-D) for subsea operation
- Nut splitters include spare chisel, spare set screw and wrench used to secure the chisel
- CR400 female half coupler standard on NSPH
- CR400 + CH604 couplers standard on NSPH-D.

ATEX certified

- All NSH-tools are CE - ATEX certified.

Versatile, reliable and trouble free operation



Blade Positioning Scale

The power head can be adjusted to preset the blade cutting distance in order to prevent damage to the bolt thread as the nut is cut.

The blade positioning scale can be used with the following bolt and nut forms:

- Unified bolt threads (UN) with heavy series hexagon nuts;
- Metric bolt threads (M) with standard series hexagon nuts.



Steel Hand Pumps

The **P80** and **P84** two speed hand pumps are ideal to operate nut splitters. The P84 can be used to power the double-acting tools.

Page: 78



High Pressure Hoses

Enerpac offers a complete line of high quality hydraulic hoses. To ensure the integrity of your system, specify only genuine Enerpac hydraulic hoses.

Page: 128

Single- and Double-Acting Hydraulic Nut Splitters



Hydraulic Nut Splitters

These Hydraulic Nut Splitters are the ideal tools for removing seized and corroded nuts, eradicating the need for unsafe grinding or flame cutting.

They are designed with a single acting spring return cylinder and boast a 360 degree rotation, lockable handle improving operator safety.

The heavy duty blades can also be easily removed to enable replacement blades to be fitted.

Operator Safety

To improve operator safety an ergonomic, adjustable handle is available which can be easily fitted to the Nut Splitter.

This lightweight, durable accessory can prevent injuries such as trapped fingers by eliminating the need to hold the tool itself.

ATEX Certified: Ex II 2 G c T6

These Nut Splitters are tested and certified to conform to the 94/9/EC "ATEX Directive". The explosion protection is for Equipment Group II, Equipment Category 2 (Hazardous Zone Area 1) in Gas and/or Dust atmospheres.

NSH Series



Bolt Range:

M45 - M90

Hexagon Nut Range:

70 - 130 mm

Maximum Operating Pressure:

700 bar

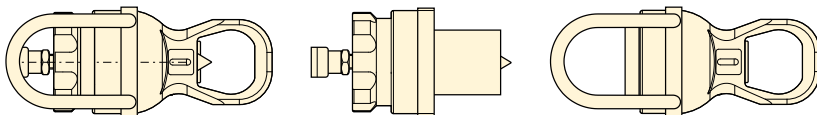

Complete Nut Splitter = Power Head (NSPH) + Cutting Head (NSH)

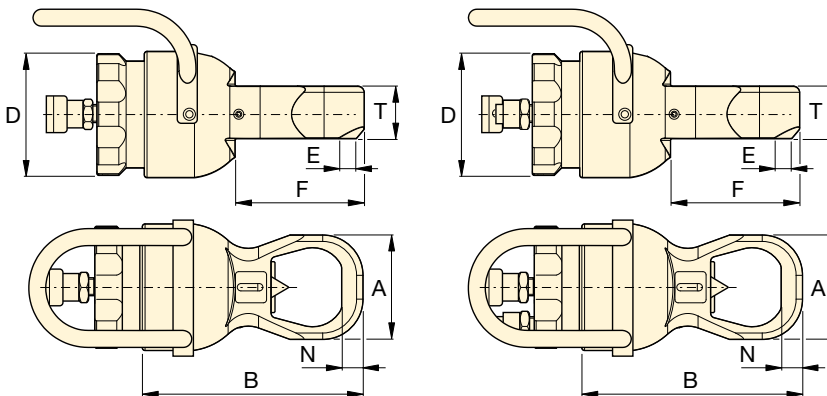

NSPH + NSH

NSPH-D + NSH



Joint Separation Tools

Flange Spreading Wedges (FSC, FSH, FSM-Serie) provide quick and easy joint separation using hydraulic or mechanical force.

Page: 316

For Power Head Model Nr.		Cutting Tip Service Kit Model Nr.
NSPH3	NSPH3D	NSPH3CTK
NSPH4	NSPH4D	NSPH4CTK

▼ NUT SPLITTER SPECIFICATIONS

Bolt Range (mm)	Hexagon Nut Range (mm)	Maximum Cutting Force ton (kN)	Oil Capacity (cm ³)	Model Numbers Nut Splitter Components				Dimensions (mm)							Cutting + Power Head (kg)	
				Cutting Head	Power Heads	Single-acting	Double-acting	A	B	D	E	F	N	T		
M45 - M52	70 - 80	105 (1025)	550	NSH31	20	NSPH3	NSPH3D	22	132	308	190	7	189	28	81	42
M45 - M56	70 - 85	105 (1025)	550	NSH32	21	NSPH3	NSPH3D	22	145	323	190	15	200	30	81	43
M45 - M64	70 - 95	105 (1025)	550	NSH33	22	NSPH3	NSPH3D	22	160	331	190	11	200	32	81	44
M45 - M70	70 - 100	105 (1025)	550	NSH34	22	NSPH3	NSPH3D	22	174	342	190	11	204	35	81	44
M76 - M80	110 - 115	178 (1733)	1100	NSH41	32	NSPH4	NSPH4D	38	189	365	235	4,5	230	36	111	70
M76 - M90	110 - 130	178 (1733)	1100	NSH42	44	NSPH4	NSPH4D	38	219	393	235	3	246	36	111	82

Ordering Notes: Maximum allowable hardness to split is ASTM A194 Gr 2H. Not to be used on square nuts or stainless steel.

▼ FF120



- Makes refacing easy – hand operated machine tool can be set up anywhere without the need for air, electric or hydraulic power
- Lightweight and portable (15 kg in storage box)
- Adjustable cutting head for reface of flat flange surfaces of pipes with flange outside diameter facing range 25,4 - 304,8 mm [1 - 12 inch]
- Interchangeable collets for ID mounting range 25,4 - 152,4 mm [1-6 inch] allow the user to work on many different flanges with minimal time between set-ups
- Interchangeable lead screws suitable for refacing damaged raised-face (RF) or flat-face (FF) joint flanges
- Tool body with expanding collets centers itself providing real concentric operation.

▼ The Enerpac FF120 used to face a pipe flange.



Safe, efficient and accurate refacing of flat pipe flange surfaces



Complete in Wheeled Carrying Case

The FF120 comes as portable set (15 kg). Can be transported, easy set-up and operated by a single

technician. Set includes:

FFL-kit with locators, O-Rings and extensions;
FSS-kit with feed screw and nut ½”-20 UN for surface roughness Ra 1,6 - 2,4 μ.

FSF-kit with feed screw and nut ½”-11 UNF for surface roughness Ra 3,2 - 6,3 μ.



Joint Separation Tools

FSC, FSH, FSM-Series parallel wedge spreaders provide quick and easy joint separation using hydraulic or mechanical force.

Page: 316



Flange Alignment Tools

The ATM-Series provide safe and high-precision flange alignment tools that fit most commonly used ANSI, API, BS and DIN flanges.

Page: 314



Controlled Tightening and Loosening

Use Enerpac Bolting Tools to seal the joint to the precise torque or tension required: torque

multipliers, torque wrenches and hydraulic bolt tensioners.

Page: 219



On-site Machining Tools

Explore the full product line from flange facing machines, milling machine, drilling and tapping machines to clamshell pipe

cutters, bevelling machines and much more.

Page: 384

QuickFace – Mechanical Pipe Flange Face Tool



Mechanical Flange Face Tool

Portable, hand powered tool makes even the hardest to reach pipe flanges resurfaceable in a safe and convenient way.

Makes refacing easy

A simple and cost effective solution – the FF120 turns a two man operation with heavy equipment, compressors and portable generators into a one man job.

The FF120 has interchangeable lead screws that make it suitable for resurfacing damaged flat-faced or raised-face joint flanges to the high safety standards required. FF120 is not suitable for lens-ring joint flanges or ring type joint (RTJ) flanges.

After selecting the correct lead screw for the operation, the tool body is inserted in the pipe end and centres itself with adjustable locators to provide real concentric operation.

The tool arm is then rotated by hand using a worm-gear mechanism to provide a perfect spiral “gramophone” finish. The tool can be adjusted with a calibrated slide to define cut depth and the correct finish.

Surface finish & accuracy

A serrated finish with 30-55 grooves per inch and a resultant roughness of between Ra 3,2-12,5 µ (125-500 micro inches). The FF-120 has same precision and quality of finish as a lathe.

Cost effective solution

Small and portable enough to be a permanent addition to your equipment range, Enerpac’s FF120 is the perfect solution to all of your small diameter facing problems.

For more Flange Facing Machines, see page 386.

FF Series



Pipe Flange Cutting Diameter Range:

Ø 25 - 305 mm / 1 - 12"

Internal Pipe Mounting Range:

Ø 25 - 152 mm / 1 - 6"

Cutting Resultant Roughness:

Ra 3,2 - 12,5 µ



- 1 Hand-operated cold work tool – no need for external power and hot work permits.
- 2 Calibrated cross slide for accurate cutting control.
- 3 Adjustable cutting head for reface of flat flange surfaces of pipes with flange OD facing range Ø 25,4-304,8 mm [1-12 inch].
- 4 Interchangeable lead screws enable selection of surface finish between Ra 3,2-12,5 µ.
- 5 Utilizes standard 3/8 inch or 10 mm tool steel.
- 6 Range of interchangeable collets allow the tool to accommodate Ø 25,4 - 152,4 mm (1 - 6 inch) pipe ID.
- 7 Tool body with expanding collets centers in the bore ensuring concentric and accurate set-up.

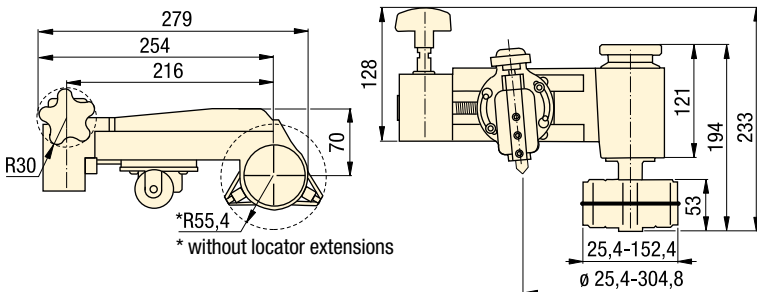
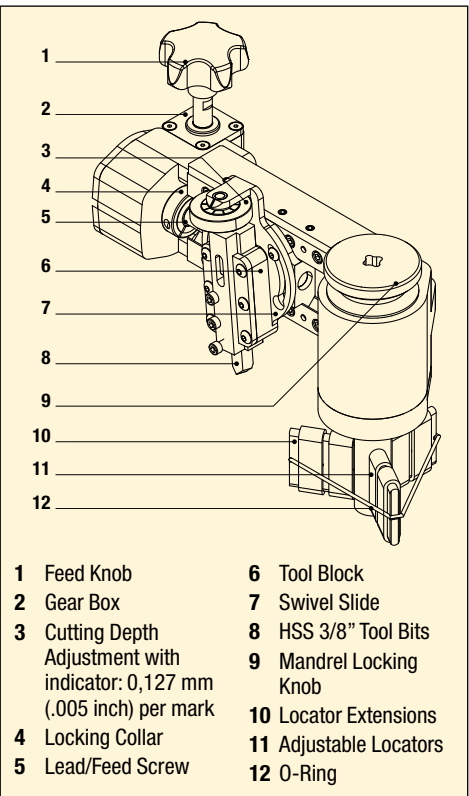

SELECTION CHART

Pipe Flange Cutting Diameter Range		Internal Pipe Mounting Diameter Range		Cutting Resultant Roughness	Model Number	Weight (kg)
(mm)	(inch)	(mm)	(inch)	(Ra µ)		
25,4 - 304,8	1,0 - 12,0	25,4 - 152,4	1,0 - 6,0	3,2 - 12,5	FF120	6,8

▼ The Enerpac FF120 QuickFace has same precision and quality of finish as a lathe.



The Equalizer™ range of patented flange spreading tools have been developed to aid and simplify the maintenance of flange joints. No longer will those tasked with separating flanges have to rely on using ropes and pulleys, podgers, tirsors, come-alongs or hammers – there is a safe, quick and effective alternative, the

Equalizer™ range of spreaders. These spreaders use mechanical and hydraulic principles for separating flanges and can spread small, medium or large flange joints. Tool selection is made on the basis of the access gap between the flange faces, the flange size and the required scope of work.

SWi Flange Spreading Wedges:

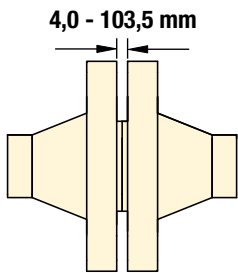

An innovative flange spreading wedge for use on small, medium or large flange joints with a minimum access gap of 4 mm. The SWi range includes ATEX approved options.

MG Flange Spreading Tool:

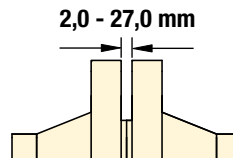

A mechanical tool for small diameter, low pressure flanges with a minimum access gap of 2 mm.

For use on smaller, lower pressure flange joints, this portable and flexible tool can be assembled in two alternative configurations that gives it twice the application range from one tool. The tool is locked onto the flange joint by the spreading bar preventing the risk of it falling from the flange joint.

The SWi range has set the new standard for spreading flange joints powerfully, efficiently, effectively and safely. The tools offer the following features and benefits:

- Wider spreading - using the Standard Stepped Block accessories means the SWi range offers up to 30% more flange spreading distance than a traditional SW tool.
- Unrivalled power - the tools now offer up to 240 kN of spreading force when used in pairs, which provides additional confidence when spreading.
- Narrower jaws - the SWi5T tools are only 50 mm wide to help them fit more easily between flange bolts.
- Fully rotational handle – the handle swivels 360-degrees around the wedge head, so that the SWi tools can be used comfortably in all orientations.
- Easier maintenance – end-users will appreciate the ease with which the tools can be maintained. The supplied hex-key and a two step-process is all that's required to disassemble and reassemble the tools.
- No pinch points – the SWi range of tools has been engineered to overcome finger pinch-points.

SG Flange Spreading Tools:

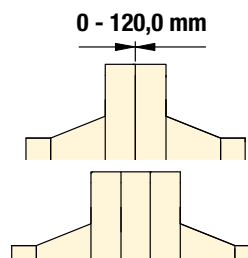

A unique flange spreader, ideal for situations where there is no access gap, or where there is a spacer, a wafer or butterfly valve positioned between the flanges.

Equalizer's unique Secure-Grip tools spread by locking into the flange bolt holes and pulling the mating flanges away from each other, the Secure Grip flange spreaders are locked on to the flanges when under load making them arguably the world's safest flange spreading tools.



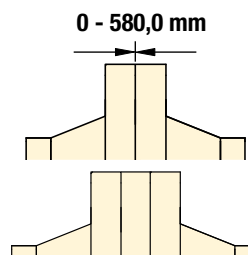







VC Valve Change-Out Tools:



Using the same technology as the SG flange spreaders the VC range has been developed for valve removal applications.

The Equalizer™ VC Range of Valve Change-Out tools has been developed to assist in the removal of valves, spades/spacers or gaskets from large flange joints. The span of the tool is longer than a standard Secure-Grip Flange Spreader and is adjustable to enable the tool to operate in a range of applications.

Flange Maintenance Tools – Overview

Capacity (kN)	Spreading Distance (mm)	Tool Type and Function	Series	Image	Page
77 - 240	4 - 103	Flange Spreading Tools and Kits Flange Spreading Wedges	SWi		328 ▶
140 - 240	6 - 103	Flange Spreading Tools and Kits Flange Spreading Wedges, ATEX-Certified	SWi		330 ▶
37 - 150	0 - 115	Flange Spreading Tools and Kits Hydraulic and Mechanical	SG		332 ▶
180 - 250	0 - 120	Flange Spreading Tools and Kits Hydraulic	SG		334 ▶
100	0 - 580	Flange Spreading Tools and Kits Secure-Grip Valve Change-Out Tools, Hydraulic	VC		336 ▶
68	2 - 27	Flange Spreading Tool and Kit Mechanical	MG		338 ▶
100	570 - 0	Flange Pulling Tool Hydraulic	FC		339 ▶
40 - 270	42 - 65	Flange Alignment Tools and Kits Wind Turbine Tower Flange Alignment Tools Hydraulic and Mechanical	TFA		340 ▶
0,3 - 1,0 ltr 2-Speed	–	Hydraulic Sealed Hand Pumps Standard and ATEX-Certified	HP		341 ▶
2 - 6 m	–	Hydraulic Hoses Standard and ATEX-Certified	144 302		341 ▶

▼ SWi5TI-S



SWi Series

FLANGE SPREADING WEDGES

Spreading Force:

77,0 - 240,0 kN

Spreading Distance:

4,0 - 103,5 mm

Maximum Operating Pressure:

700 bar *

* Only relevant for hydraulic tools

- Practical, portable and lightweight
- Revolving handle to aid horizontal or vertical spreading
- Removable handle for improved access
- No finger pinch-point
- Increased step-depth on upper steps
- Safety lanyard – 1,0 m length
- Forged key components for strength and reliability
- Rapid disassembly and assembly
- Narrow jaw teeth – improved tool wear.



Caution

A minimum of two Flange Spreading Tools must be used when opening flange joints. This will enable the operator to maintain an equal spreading distance across the flange faces.

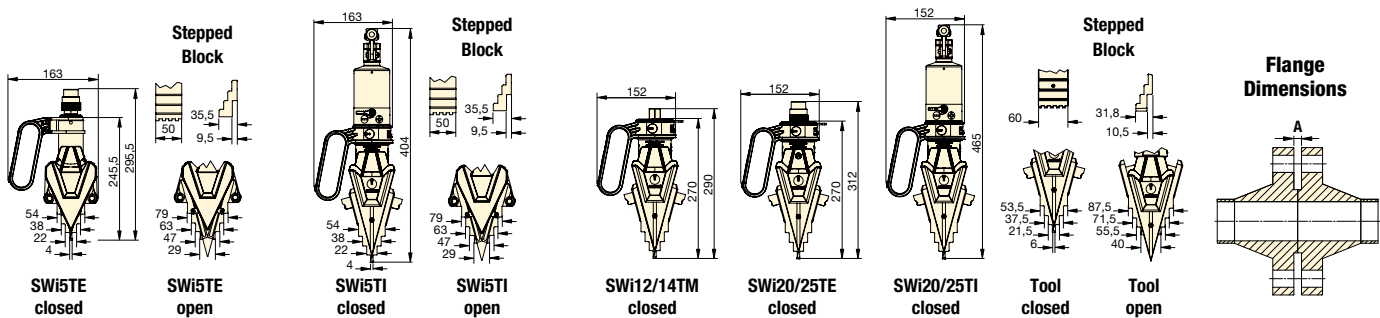

Model Number Tool Kit	Type	Maximum Spreading Force Per Tool (kN)	Spreading Distance Maximum * (mm)	Flange Dimensions Minimum Access Gap A (mm)	Jaw Width (mm)	Tool Weight (kg)	Kit Weight (kg)	Case Dimensions (mm)	Tool Number
SWi5TE-S	External Hydraulic	77,0	101,0	4,0	50,0	5,2	8,7	580 x 340 x 180	SWi5TE
SWi5TE-T	External Hydraulic	77,0	101,0	4,0	50,0	5,2	14,4	580 x 340 x 180	SWi5TE
SWi5TI-S	Integral Hydraulic	77,0	101,0	4,0	50,0	7,0	10,5	580 x 330 x 180	SWi5TI
SWi1214TMSTDSPB	Mechanical	140,0	103,5	6,0	60,0	6,2	13,0	580 x 330 x 165	SWi12/14TM
SWi2025TEMINSBPB	External Hydraulic	240,0	103,5	6,0	60,0	6,4	11,6	580 x 330 x 165	SWi20/25TE
SWi2025TESTDSPB	External Hydraulic	240,0	103,5	6,0	60,0	6,4	20,7	920 x 500 x 205	SWi20/25TE
SWi2025TEMAXSPB	External Hydraulic	240,0	103,5	6,0	60,0	6,4	33,0	920 x 500 x 205	SWi20/25TE
SWi2025TISTDSPB	Integral Hydraulic	240,0	103,5	6,0	60,0	8,5	13,8	580 x 330 x 165	SWi20/25TI

* Using stepped blocks.

Flange Spreading Tools

SWi5TE - Hydraulic Flange Spreading Wedge

SWi5TE-S - SWi5TE S Kit



- 1 x SWi5TE Flange Spreading Tool
- 1 x Standard Safety Block
- 1 x Lanyard
- 1 x Moulded Plastic Carry Case with Protective Foam Inserts

SWi5TE-T - SWi5TE T Kit



- 2 x SWi5TE Flange Spreading Tools
- 2 x Standard Safety Blocks
- 2 x Lanyards
- 1 x Moulded Plastic Carry Case with Protective Foam Inserts

1640016-01 - SWi5TE Stepped Block Kit



- 1 x Pair of SWi5TE Stepped Blocks
- 2 x M6 CSK Hex Screw
- 2 x Retaining Washer
- 1 x SWi5TE Large Safety Block
- 2 x Hex Key

SWi12/14TM - Mechanical Flange Spreading Wedge

SWi1214TMSTDSPB - SWi12/14TM STD Kit



- 1 x SWi12/14TM Flange Spreading Tool
- 1 x Torque Wrench with 22 mm Socket
- 1 x Set of Safety Blocks
- 1 x Pair of Stepped Blocks
- 1 x Lanyard
- 1 x Hex Key
- 1 x Moulded Plastic Carry Case

SWi20/25TE - Hydraulic Flange Spreading Wedge

SWi2025TEMINSPB - SWi20/25TE MIN Kit



- 1 x SWi20/25TE Flange Spreading Tool
- 1 x Set Safety Blocks
- 1 x Pair of Stepped Blocks
- 1 x Lanyard
- 1 x Hex Key
- 1 x Moulded Plastic Carry Case

SWi2025TESTDSPB - SWi20/25TE STD Kit



- 1 x SWi20/25TE Flange Spreading Tool
- 1 x 700 bar Hydraulic Hose, 2 m with 90° Elbow
- 1 x 700 bar HP350S Single-Port Sealed Hand Pump with Gauge
- 1 x Set Safety Blocks
- 1 x Pair of Stepped Blocks
- 1 x Lanyard
- 1 x Hex Key
- 1 x Moulded Plastic Carry Case

SWi2025TEMAXSPB - SWi20/25TE MAX Kit



- 2 x SWi20/25TE Flange Spreading Tools
- 2 x 700 bar Hydraulic Hoses, 2 m with 90° Elbow
- 1 x 700 bar HP550D Twin-Port Sealed Hand Pump with Gauge
- 2 x Set Safety Blocks
- 2 x Pair of Stepped Blocks
- 2 x Lanyards
- 2 x Hex Keys
- 1 x Moulded Plastic Carry Case

SWi5TI - Integral Hydraulic Flange Spreading Wedge

SWi5TI-S - SWi5TI S Kit



- 1 x SWi5TI Flange Spreading Tool
- 1 x Standard Safety Block
- 1 x Lanyard
- 1 x Moulded Plastic Carry Case with Protective Foam Inserts

1640016-01 - SWi5TE Stepped Block Kit



- 1 x Pair of SWi5TE Stepped Blocks
- 2 x M6 CSK Hex Screw
- 2 x Retaining Washer
- 1 x SWi5TE Large Safety Block
- 2 x Hex Key

SWi20/25TI - Integral Hydraulic Flange Spreading Wedge

SWi2025TISTDSPB - SWi20/25TI STD Kit



- 1 x SWi20/25TI Flange Spreading Tool
- 1 x Set of Safety Blocks
- 1 x Pair of Stepped Blocks
- 1 x Lanyard
- 1 x Hex Key
- 1 x Carry-Strap
- 1 x Moulded Plastic Carry Case

▼ SWi20/25TEEX



ATEX
CERTIFIED

- ATEX certified
- Practical, portable and lightweight
- Revolving handle to aid horizontal or vertical spreading
- Removable handle for improved access
- No finger pinch-point
- Increased step-depth on upper steps
- Safety lanyard – 1,0 m length
- Forged key components for strength and reliability
- Rapid disassembly and assembly
- Narrow jaw teeth – improved tool wear.

SWi Series



ATEX CERTIFIED FLANGE
SPREADING WEDGES

Spreading Force:

140,0 - 240 kN

Spreading Distance:

6,0 - 103,5 mm

Maximum Operating Pressure:

700 bar *

* Only relevant for hydraulic tools



Caution

A minimum of two Flange Spreading Tools must be used when opening flange joints. This will enable the operator to maintain an equal spreading distance across the flange faces.

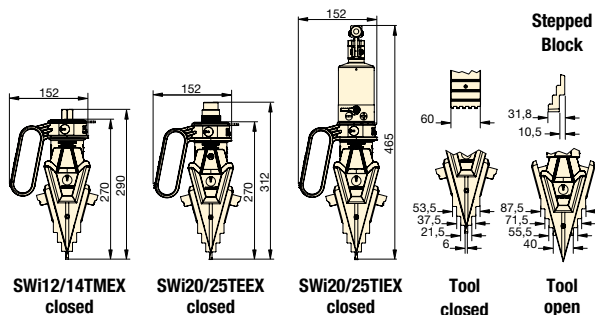

Flange Dimensions

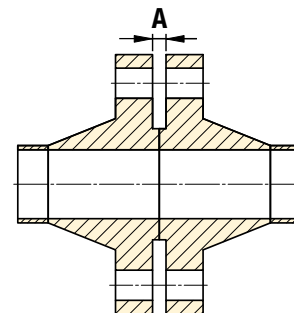

Model Number Tool Kit	Type	Maximum Spreading Force Per Tool (kN)	Spreading Distance Maximum * (mm)	Flange Dimensions Minimum Access Gap A (mm)	Jaw Width (mm)	Tool Weight (kg)	Kit Weight (kg)	Case Dimensions (mm)	Tool Number
SWi1214TMSTDEX	Mechanical	140,0	103,5	6,0	60,0	6,2	17,0	580 x 400 x 180	SWi12/14TMEX
SWi2025TEMINEX	External Hydraulic	240,0	103,5	6,0	60,0	6,4	15,0	580 x 400 x 180	SWi20/25TEEX
SWi2025TESTDEX	External Hydraulic	240,0	103,5	6,0	60,0	6,4	27,5	680 x 560 x 180	SWi20/25TEEX
SWi2025TEMAXEX	External Hydraulic	240,0	103,5	6,0	60,0	6,4	38,8	930 x 600 x 180	SWi20/25TEEX
SWi2025TISTDEX	Integral Hydraulic	240,0	103,5	6,0	60,0	8,5	17,5	580 x 400 x 180	SWi20/25TIEX

* Using stepped blocks.

Flange Spreading Tools

SWi12/14TMEX -
ATEX Certified Mechanical
Flange Spreading Wedge



II 2G Ex h IIB T5 Gb
II 2D Ex h IIIC T85°C Db

SWi1214TMSTDEX - SWi12/14TMEX STD Kit



1 x SWi12/14TMEX Flange Spreading Tool
1 x ATEX Torque Wrench with 22 mm Socket
1 x Set of Safety Blocks
1 x Pair of Stepped Blocks
1 x Lanyard
1 x Hex Key
1 x Aluminium Carry Case with Protective Foam Inserts

SWi20/25TEEX -
ATEX Certified Hydraulic
Flange Spreading Wedge



II 2G Ex h IIB T5 Gb
II 2D Ex h IIIC T100°C Db

SWi2025TEMINEX - SWi20/25TEEX MIN Kit



1 x SWi20/25TEEX Flange Spreading Tool
1 x Set Safety Blocks
1 x Pair of Stepped Blocks
1 x Lanyard
1 x Hex Key
1 x Aluminium Carry Case with Protective Foam Inserts

SWi20/25TIEX -
ATEX Certified Integral Hydraulic
Flange Spreading Wedge



II 2G Ex h IIB T5 Gb
II 2D Ex h IIIC T100°C Db

SWi2025TISTDEX - SWi20/25TIEX STD Kit



1 x SWi20/25TIEX Flange Spreading Tool
1 x Set of Safety Blocks
1 x Pair of Stepped Blocks
1 x Lanyard
1 x Hex Key
1 x Carry-Strap
1 x Aluminium Carry Case with Protective Foam Inserts

SWi2025TESTDEX - SWi20/25TEEX STD Kit



1 x SWi20/25TEEX Flange Spreading Tool
1 x 700 bar ATEX Hydraulic Hose, 2 m with 90° Elbow
1 x 700 bar HP350S ATEX Single-Port Sealed Hand Pump with Gauge
1 x Set Safety Blocks
1 x Pair of Stepped Blocks
1 x Lanyard
1 x Hex Key
1 x Aluminium Carry Case with Protective Foam Inserts

SWi2025TEMAXEX - SWi20/25TEEX MAX Kit



2 x SWi20/25TEEX Flange Spreading Tools
2 x 700 bar ATEX Hydraulic Hose, 2 m with 90° Elbow
1 x 700 bar HP500D ATEX Twin-Port Sealed Hand Pump with Gauge
2 x Set Safety Blocks
2 x Pair of Stepped Blocks
2 x Lanyards
2 x Hex Keys
1 x Aluminium Carry Case with Protective Foam Inserts



These tools have been designed for use in potentially explosive atmospheres which is:

- Group II (Non-mining equipment)
- Equipment **category 2** where explosive atmosphere is likely to occur in normal operation
- Can be applied in **zones 1 and 2** of gaseous explosive atmospheres and in **zones 21 and 22** of dust explosive atmosphere
- **Gas G** or **Dust D** with type of protection **Ex h** for non-electrical equipment
- Suitable for use with **Group IIB** of a gases and vapours (Ethylene group) and **Group IIIC** of dust (conductive dust)

- For hydraulic tools **T5** means that minimum ignition temperature of gas or vapor **>100°C**; **T100°C** means that minimum ignition temperature of a dust cloud $\geq 150^\circ\text{C}$ and minimum ignition temperature of a 5mm dust layer $\geq 175^\circ\text{C}$
- For mechanical tools **T6** means that minimum ignition temperature of gas or vapor **>85°C**; **T85°C** means that minimum ignition temperature of a dust cloud $\geq 127,5^\circ\text{C}$ and minimum ignition temperature of a 5mm dust layer $\geq 160^\circ\text{C}$.

These tools have been designed and manufactured in accordance with the following transposed harmonized European standards:

- **EN ISO 80079-36:2016** Explosive atmospheres - Part 36: Non-electrical equipment for explosive atmospheres - Basic method and requirements;
- **EN ISO 80079-37:2016** Explosive atmospheres - Part 37: Non-electrical equipment for explosive atmospheres - Non-electrical type of protection constructional safety "c", control of ignition sources "b", liquid immersion "k":

▼ SG11TM



- For use on all flange types with bolt-hole sizes ranging from 17,5 mm to 62,0 mm
- Unique expanding collet technology
- Little or no access gap required
- Secure bolt-hole locking mechanism.

OPERATING BENEFITS

- Time-saving, simple operation
- Measurable, controlled flange spreading force
- Virtually universal, the Secure-Grip Flange Spreader range covers ANSI, DIN, SPO, ASME, API and BS flanges.



Range of Application

For a detailed range of application please request the Secure-Grip Mechanical or Hydraulic Operator Instruction Sheet.



Caution

A minimum of two Flange Spreading Tools must be used when opening flange joints. This will enable the operator to maintain an equal spreading distance across the flange faces.

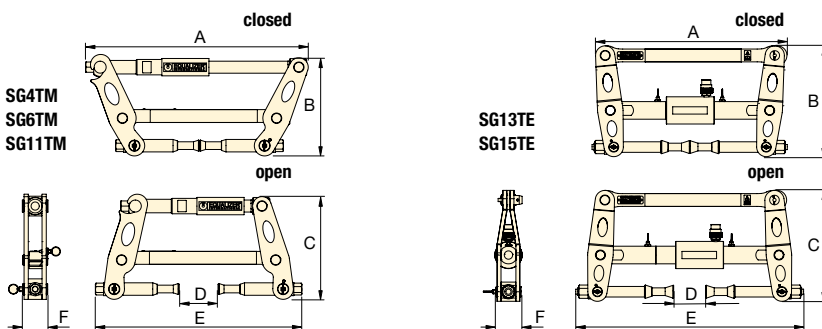

Flange Dimensions

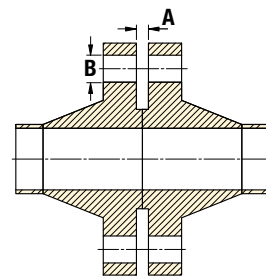

Model Number Tool Kit	Type*	Maximum Spreading Force Per Tool (kN)	Spreading Distance Maximum (mm)	Flange Dimensions (mm)		Tool Dimensions (mm)						Tool Weight (kg)	Kit Weight (kg)	Case Dimensions (mm)	Tool Number
				Minimum Access Gap A	Bolt-hole Diameter B	A	B	C	D	E	F				
SG4TMSTD	M	37,0	75	0	17,5 - 23	398	190	182	75	385	48	4,5	12,8	520x375x165	SG4TM
SG6TMSTD	M	60,0	80	0	24 - 30	468	245	252	80	444	52	7,5	16,0	640x540x165	SG6TM
SG11TMSTD	M	110,0	90	0	30 - 39	516	250	263	90	462	60	10,5	20,0	640x540x165	SG11TM
SG13TESTD	H	130,0	115	0	38 - 49	516	303	314	115	630	72	21,5	40,5	890x570x165	SG13TE
SG15TESTD	H	150,0	100	0	47,5 - 62	600	346	380	100	720	80	26,0	45,0	890x570x165	SG15TE

* M = Mechanical
H = Hydraulic

Flange Spreading Tools

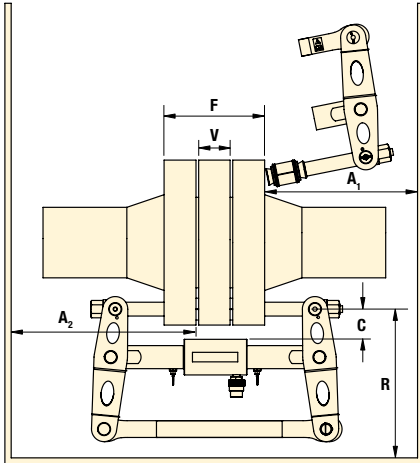

Spreading Force:
37,0 - 150,0 kN

Spreading Distance:
0 - 115 mm

Maximum Operating Pressure:
700 bar *

* Only relevant for hydraulic tools

SG Series



Model Number	Flange Joint Thickness F			Valve / Spacer Thickness V			Flange Clearance C		Radial Space R		Axial Space (for installation) A ₁		Axial Space (installed) A ₂		Tool Number
	Min. (mm)	Max. (mm)	Measured: From / To	Min. (mm)	Max. (mm)	Measured: From / To	Max. (mm)	Measured: From / To	Min. (mm)	Measured: From / To	Min. (mm)	Measured: From / To	Min. (mm)	Measured: From / To	
SG4TMSTD	60	185	Outside face of flange / Outside face of flange	0*	45*	Inside face of flange / Inside face of flange	50	Bolt-hole circle / Largest OD of valve/spacer	170	Bolt-hole circle / Closest obstruction	170	Outside face of flange / Closest obstruction	200	Inner face of flange / Closest obstruction	SG4TM
SG6TMSTD	60	210		0*	50*		55		230		200		234		
SG11TMSTD	96	240		0*	60*		60		240		223		258		
SG13TESTD	120	310		0*	95*		70		280		310		260		
SG15TESTD	140	400		0*	80*		80		370		380		315		

* Short Collet Holder Kits (SCH) are available which can offer improved range of application.

SG4TM MECHANICAL TOOL KIT



- 1 x SG4TM Tool
- 1 x 150 mm Vernier Calliper
- 1 x 3/8" Drive Torque Wrench and 16 mm Socket
- 1 x Safety Block
- 2 x M16 (5/8") Collets
- 2 x M20 (3/4") Collets
- 1 x Aluminium Carry Case with Protective Foam Inserts

SG6TM MECHANICAL TOOL KIT



- 1 x SG6TM Tool
- 1 X 150 mm Vernier Calliper
- 1 X 3/8" Drive Torque Wrench and 21 mm Socket
- 1 x Safety Block
- 2 x M24 (7/8") Collets
- 2 x M27 (1") Collets
- 1 x Aluminium Carry Case with Protective Foam Inserts

SG11TM MECHANICAL TOOL KIT



- 1 x SG11TM Tool
- 1 x 150 mm Vernier calliper
- 1 x 1/2" Drive torque wrench and 24 mm socket
- 1 x Safety block
- 2 x M30 (1-1/8") Collets
- 2 x M33 (1-1/4") Collets
- 2 x M36 (1-3/8") Collets
- 1 x Aluminium Carry Case with Protective Foam Inserts

SG13TE HYDRAULIC TOOL KIT



- 1 x SG13TE Tool
- 1 x 700 bar HP550S Single Port Sealed Hand Pump with Gauge
- 1 x 700 bar Hydraulic Hose, 2 m
- 1 x 150 mm Vernier Calliper
- 1 x 1/2" Square Drive Flexible Handle
- 1 x 30 mm Socket
- 1 x Safety Block
- 2 x M39 (1-1/2") Collets
- 2 x M42 (1-5/8") Collets
- 2 x M45 (1-3/4") Collets
- 1 x Aluminium Carry Case with Protective Foam Inserts

SG15TE HYDRAULIC TOOL KIT



- 1 x SG15TE Tool
- 1 x 700 bar HP550S Single Port Sealed Hand Pump with Gauge
- 1 x 700 bar Hydraulic Hose, 2 m
- 1 x 300 mm Vernier Calliper
- 1 x 1/2" Square Drive Flexible Handle
- 1 x 36 mm Socket
- 1 x Safety Block
- 2 x M48 (1-7/8") Collets
- 2 x M52 (2") Collets
- 2 x M56 (2-1/4") Collets
- 1 x Aluminium Carry Case with Protective Foam Inserts

▼ SG18TE & SG25TE



- Applicable for larger-sized flanges
- Actuated by an external hand pump
- Suitable for bolt holes from 59,5 mm to 108 mm.

SG18TE

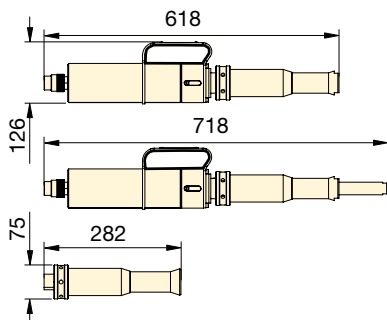

SG25TE

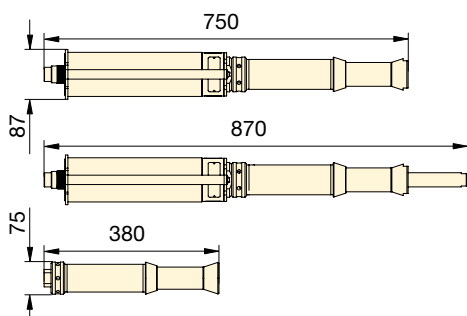

Range of Application

For a detailed range of application please request the Secure-Grip In-Line Hydraulic Operator Instruction Sheet.



Caution

A minimum of two Flange Spreading Tools must be used when opening flange joints. This will enable the operator to maintain an equal spreading distance across the flange faces.

Flange Dimensions

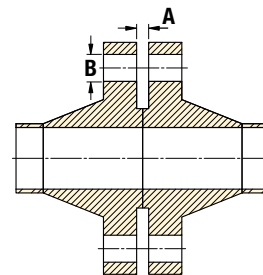

Model Number Tool Kit	Type	Maximum Spreading Force Per Tool (kN)	Spreading Distance Maximum (mm)	Flange Dimensions (mm)		Tool Weight (kg)	Kit Weight (kg)	Case Dimensions (mm)	Tool Number
				Minimum Access Gap A	Bolt-hole Diameter B				
SG18TESTD	Hydraulic	180,0	100	0	59,5 - 75	14	45	890 x 570 x 165	SG18TE
SG25TESTD	Hydraulic	250,0	120	0	75 - 108	24	50	890 x 570 x 165	SG25TE

Flange Spreading Tools

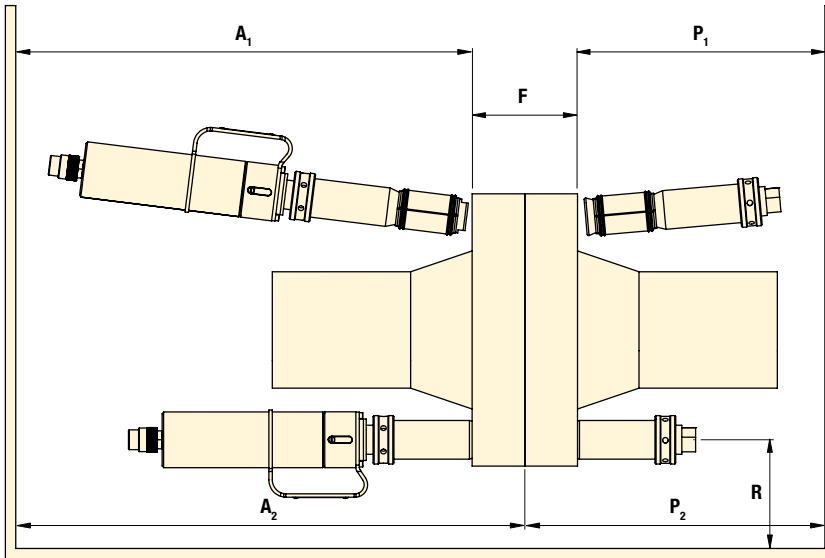

SG Series



Spreading Force:

180,0 - 250,0 kN

Spreading Distance:

0 - 120 mm

Maximum Operating Pressure:

700 bar

Model Number Tool Kit	Flange Joint Thickness F			Radial Space R		Axial Space (for installation) A1		Axial Space (installed) A2		Axial Plug Space (for installation) P1		Axial Plug Space (installed) P2		Tool Number
	Min. (mm)	Max. (mm)	Measured: From / To	Min. (mm)	Measured: From / To	Min. (mm)	Measured: From / To	Min. (mm)	Measured: From / To	Min. (mm)	Measured: From / To	Min. (mm)	Measured: From / To	
SG18TESTD	190	450	Outside face of flange/ Outside face of flange	55	Bolt-hole circle / Closest obstruction	620	Outside face of flange/ Closest obstruction	900	Inner face of flange/ Closest obstruction	283	Outside face of flange/ Closest obstruction	283	Inner face of flange/ Closest obstruction	SG18TE
SG25TESTD	210	570	Outside face of flange/ Outside face of flange	55	Bolt-hole circle / Closest obstruction	750	Outside face of flange/ Closest obstruction	1100	Inner face of flange/ Closest obstruction	380	Outside face of flange/ Closest obstruction	380	Inner face of flange/ Closest obstruction	SG25TE

SG18TE HYDRAULIC TOOL KIT



- 1 x SG18TE Tool
- 1 x Spreading Plug
- 1 x 700 bar HP550S Single Port Sealed Hand Pump with Gauge
- 1 x 700 bar Hydraulic Hose, 2 m
- 1 x 300 mm Vernier Calliper
- 1 x 12.5 mm Spacer Plate
- 1 x 5mm Allen Key
- 1 x 50 mm Spacer
- 1 x Safety Block
- 2 x M60 (2-3/8") Collets
- 2 x M64 (2-1/2") Collets
- 2 x M70 (2-3/4") Collets
- 1 x Aluminium Carry Case with Protective Foam Inserts

SG25TE HYDRAULIC TOOL KIT



- 1 x SG25TE Tool
- 1 x Spreading Plug
- 1 x 700 bar HP550S Single Port Sealed Hand Pump with Gauge
- 1 x 700 bar Hydraulic Hose, 2 m
- 1 x 300 mm Vernier Calliper
- 1 x 12.5 mm Spacer Plate
- 1 x Safety Block
- 1 x Aluminium Carry Case with Protective Foam Inserts

SG25TE COLLETS (AVAILABLE SEPARATELY)

Model Number	Description
673601-01	2 x M76 (3") Collets
674801-01	2 x M90 (3-1/2") Collets
673901-01	2 x M80 (3-1/4") Collets
675101-01	2 x M95 (3-3/4") Collets
674501-01	2 x M84 (3-3/8") Collets
675601-01	2 x M100 (4") Collets

▼ VC10TE



Secure-Grip Valve Change-Out Tools



Caution

A minimum of two Flange Spreading Tools must be used when opening flange joints. This will enable the operator to maintain an equal spreading distance across the flange faces.

- Assists in the removal of wafer/butterfly valves, spades/spacers or gaskets from large flange joints
- Tool span is longer than a standard Secure-Grip Flange Spreader
- Adjustable to enable the tool to operate in a range of situations.



The Actuator and Extension Subassembly can be assembled into 4 different configurations to suit a variety of applications. For a detailed range of application please request the VC10 Operator Instruction Sheet.

PATENTED SECURE-GRIP SYSTEM:

- Unique expanding collet technology
- Secure bolt-hole locking mechanism
- Unique technology makes the Secure-Grip arguably the safest flange spreader available in the world today
- Virtually universal, the Secure-Grip Flange Spreader range will cover ANSI, DIN, Norsok L005, ASME, API and BS Flanges
- Time-saving, simple operation.

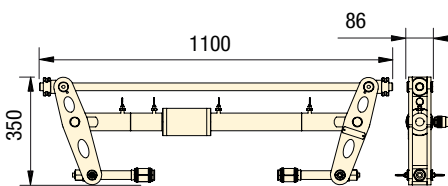

Flange Dimensions

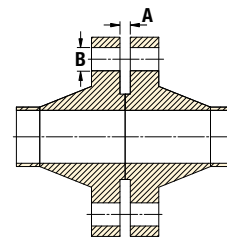

Model Number Tool Kit	Type*	Maximum Spreading Force Per Tool (kN)	Spreading Distance Maximum (mm)	Flange Dimensions (mm)		Tool Kit Weight (kg) (2 per Maxi Kit)	Pump Kit Weight (kg)	Gross Kit Weight (kg)	Tool Case Dimensions (mm)	Pump Case Dimensions (mm)	Tool Number
				Minimum Access Gap A	Bolt-hole Diameter B						
VC10/13TESTD	H	100	580	0	38 - 49	50	27	77	550x1200x170	550x1200x170	VC10/13TE
VC10/13TEMAX	H	100	580	0	38 - 49	50	30	130	550x1200x170	550x1200x170	VC10/13TE
VC10/15TESTD	H	100	560	0	47,5 - 62	53	27	80	550x1200x170	550x1200x170	VC10/15TE
VC10/15TEMAX	H	100	560	0	47,5 - 62	53	30	136	550x1200x170	550x1200x170	VC10/15TE
VC10/18TESTD	H	100	514	0	59,5 - 75	58	27	85	550x1200x170	550x1200x170	VC10/18TE
VC10/18TEMAX	H	100	514	0	59,5 - 75	58	30	146	550x1200x170	550x1200x170	VC10/18TE
VC10/25TESTD	H	100	490	0	75 - 108	58	27	85	550x1200x170	550x1200x170	VC10/25TE
VC10/25TEMAX	H	100	490	0	75 - 108	58	30	146	550x1200x170	550x1200x170	VC10/25TE

* H = Hydraulic

Flange Spreading Tools

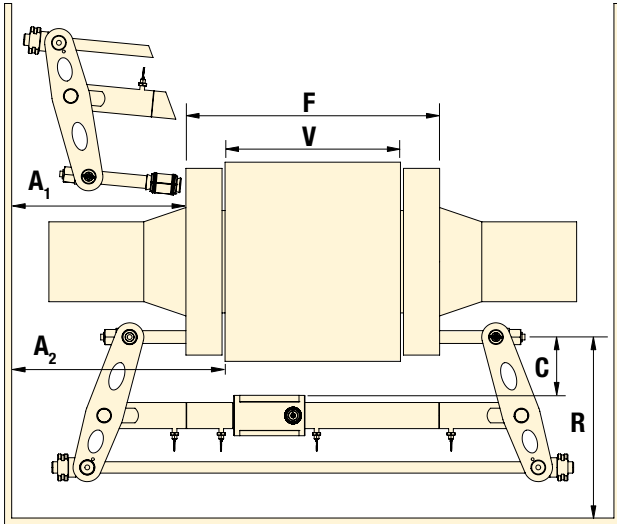

VC Series



Spreading Force:
100 kN

Spreading Distance:
0 - 580 mm

Maximum Operating Pressure:
700 bar

Model Number Tool Kit	Flange Joint Thickness F			Valve / Spacer Thickness V			Flange Clearance C	Radial Space R	Axial Space (for installation) A ₁	Axial Space (installed) A ₂	Tool Number
	Min. (mm)	Max. (mm)	Measured: From / To	Min. (mm)	Max. (mm)	Measured: From / To					
VC10/13TESTD	110	690	Outside face of flange / Closest obstruction - min. 300 mm	0*	580*	Inside face of flange / Closest obstruction - min. 370 mm	Bolt-hole circle / Largest OD of valve/spacer - max. 130 mm	Bolt-hole circle / Closest obstruction - min. 360 mm	Outside face of flange / Closest obstruction - min. 300 mm	Inner face of flange / Closest obstruction - min. 370 mm	VC10/13TE
VC10/13TEMAX	110	690		0*	580*						VC10/13TE
VC10/15TESTD	130	690		0*	560*						VC10/15TE
VC10/15TEMAX	130	690		0*	560*						VC10/15TE
VC10/18TESTD	176	690		0*	514*						VC10/18TE
VC10/18TEMAX	176	690		0*	514*						VC10/18TE
VC10/25TESTD	200	690		0*	490*						VC10/25TE
VC10/25TEMAX	200	690		0*	490*						VC10/25TE

* Short Collet Holder Kits (SCH) are available which can offer improved range of application.

TOOL KITS (1 PER STD KIT, 2 PER MAX KIT)



VC10/13TE 1 x VC10/13TE Tool 2 x M39 (1-1/2") Collets 2 x M42 (1-5/8") Collets 2 x M45 (1-3/4") Collets 1 x Aluminium Carry Case with Protective Foam Inserts	VC10/18TE 1 x VC10/18TE Tool 2 x M60 (2-3/8") Collets 2 x M64 (2-1/2") Collets 2 x M70 (2-3/4") Collets 1 x Aluminium Carry Case with Protective Foam Inserts
VC10/15TE 1 x VC10/15TE Tool 2 x M48 (1-7/8") Collets 2 x M52 (2") Collets 2 x M56 (2-1/4") Collets 1 x Aluminium Carry Case with Protective Foam Inserts	VC10/25TE 1 x VC10/25TE Tool 1 x Aluminium Carry Case with Protective Foam Inserts

PUMP KITS



For STD Tool Kits
 1 x 700 bar HP550S Single Port Hydraulic Hand Pump
 1 x Hydraulic Gauge with Manifold
 1 x 700 bar Hydraulic Hose, 2,0 m
 1 x Secure Grip Safety Block
 1 x Square Drive Flexible Handle
 1 x Vernier Calliper
 1 x Aluminium Carry Case with Protective Foam Inserts

For MAX Tool Kits
 1 x 700 bar HP1000D Twin Port Hydraulic Hand Pump
 2 x Hydraulic Gauges with Manifolds
 2 x 700 bar Hydraulic Hoses, 2,0 m
 2 x Secure Grip Safety Blocks
 1 x Square Drive Flexible Handle
 1 x Vernier Calliper
 1 x Aluminium Carry Case with Protective Foam Inserts



Collet Sizing

It is important that the correct size of collet is used. An undersized collet could allow the collet holder to pull through its bore. An oversized collet has the potential to become jammed in the bolt-hole.



Range of Application

For a detailed range of application please request the Hydraulic Secure-Grip Valve Change-Out Tool Operator Instruction Sheet.

VC10/25TE COLLETS (AVAILABLE SEPARATELY)

Model Number	Description
673601-01	2 x M76 (3") Collets
673901-01	2 x M80 (3-1/4") Collets
674501-01	2 x M84 (3-3/8") Collets
674801-01	2 x M90 (3-1/2") Collets
675101-01	2 x M95 (3-3/4") Collets
675601-01	2 x M100 (4") Collets

▼ MG7TM



- Reversible leg design giving greater range of applications
- Unique double-angled wedge produces a greater spreading force without reducing spreading distance
- Robust lightweight tool
- Spreading force of 68,0 kN.

OPERATING BENEFITS

- Locks on to flange joint
- Safe, quick and easy operation
- Saves time and cost.

MG Series

FLANGE SPREADING TOOL

Spreading Force:

68,0 kN

Spreading Distance:

2,0 - 27,0 mm



Range of Application

For a detailed range of application please request the MG7TM Operator Instruction Sheet.



Caution

A minimum of two Flange Spreading Tools must be used when opening flange joints. This will enable the operator to maintain an equal spreading distance across the flange faces.

MG7TMSTD Standard Kit



- 1 x MG7TM Tool
- 2 x Spreading Bar
- 1 x Moulded Plastic Carry Case

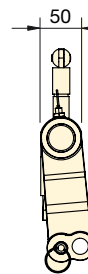
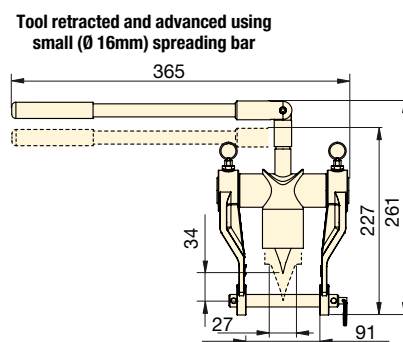
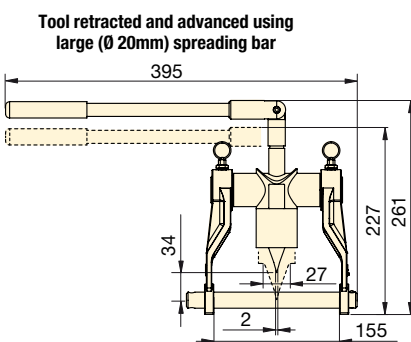

Flange Dimensions

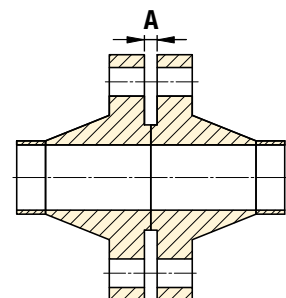

Model Number Tool Kit	Type	Maximum Spreading Force Per Tool (kN)	Spreading Distance Maximum (mm)	Flange Dimensions Minimum Access Gap A (mm)	Wedge Width (mm)	Tool Weight (kg)	Kit Weight (kg)	Case Dimensions (mm)	Tool Number
MG7TMSTD	Mechanical	68,0	27,0	2,0	45,0	5,0	5,5	360 x 300 x 90	MG7TM

Flange Pulling Tools

▼ FC10TE



- Applicable to all flanges with a bolt-hole diameter of 1 inch or greater, including ANSI, DIN, Norsok L005, ASME and BS flanges
- Slide and lock collet system
- Low profile tool
- Can be used on all vertical and horizontal flanges including ANSI, API, BS, DIN & Norsok L005
- Robust yet light weight
- Subsea compatible
- Reciprocating hydraulic action.

OPERATING BENEFITS

- Reduction in operator fatigue
- Reduction in pinch point
- Quick and easy to use.

Flange Dimensions

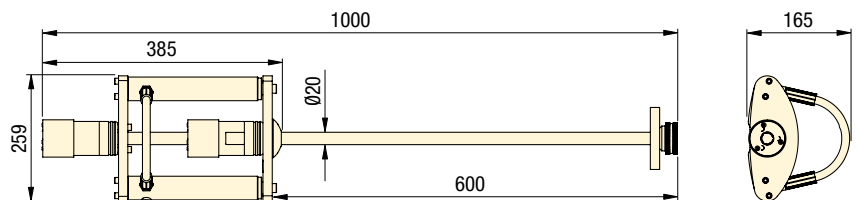
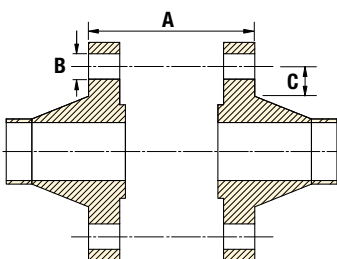

FC Series

FLANGE CLOSING TOOLS

Closing Force:
100 kN

Closing Distance:
570 - 0 mm

Maximum Operating Pressure:
700 bar



Caution

A minimum of two flange closing tools must be used when flange pulling. This will enable the operator to maintain an even gap between flange faces and prevent flange / gasket damage.

FC10TESTD STD Kit



- 1 x FC10TE Tool
- 1 x 700 bar Hydraulic Hose, 2 m long
- 1 x 700 bar HP550S Single Port Sealed Hand Pump with Gauge
- 1 x Aluminium Carry Case with Protective Foam Inserts

FC10TEMAX MAX Kit



- 2 x FC10TE Tool
- 2 x 700 bar Hydraulic Hoses, 2 m long
- 1 x 700 bar HP550D Twin Port Sealed Hand Pump with Gauge
- 1 x Aluminium Carry Case with Protective Foam Inserts

Model Number Tool Kit	Type	Maximum Closing Force Per Tool (kN)	Closing Distance (mm)	Flange Dimensions (mm)			Tool Weight (kg)	Kit Weight (kg)	Box/Case Dimensions (mm)	Tool Number
				A	B min	C min				
FC10TESTD	Hydraulic	100	570	16-570	25,4*	32	11	23,5	890 x 570 x 165	FC10TE
FC10TEMAX	Hydraulic	100	570	16-570	25,4*	32	11	36,5	890 x 570 x 165	FC10TE

* For hole diameter greater than 45mm, please contact Enerpac.

▼ TFA15TI



TFA Series

**WIND TURBINE TOWER
FLANGE ALIGNMENT TOOLS**

Hook Force:

40 - 270 kN

Aligning Distance:

42 - 65 mm

TFA4TM Mechanical Tool Kit



- 1 x TFA4TM Tool
- 1 x Torque Wrench
- 1 x Moulded Plastic Carry Case

TFA12TE / TFA15TE External Hydraulic Tool Kit



- 1 x TFA12TE or TFA15TE Tool
- 1 x Safety Lanyard
- 1 x Aluminium Carry Case with Protective Foam Inserts

TFA12TI / TFA15TI Internal Hydraulic Tool Kit



- 1 x TFA12TI or TFA15TI Tool
- 1 x Aluminium Carry Case with Protective Foam Inserts

The TFA Wind Turbine Tower Flange Alignment Tools have been developed to aid the alignment of large flanges on the inside of wind turbine towers during their assembly or installation.

- Assists in aligning / de-ovalizing large internal pipe flanges
- Helps resolve bolt-hole misalignment within tower sections of wind turbine towers
- Can be used both on and offshore.

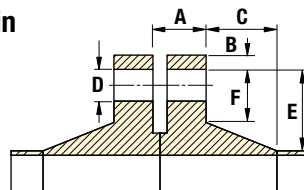

Flange Dimensions

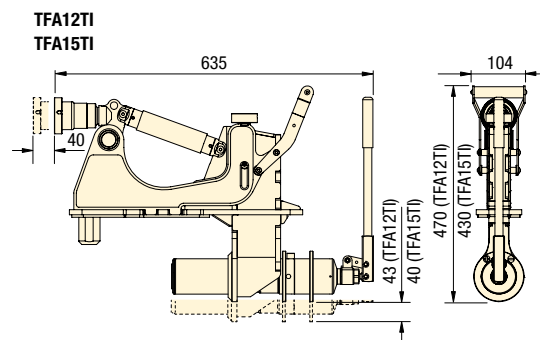
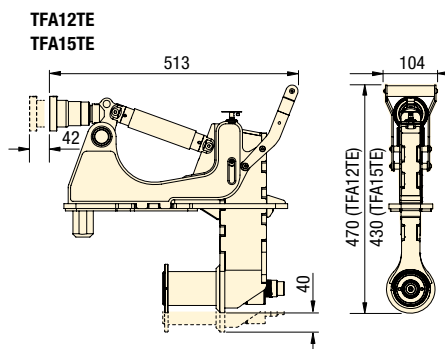
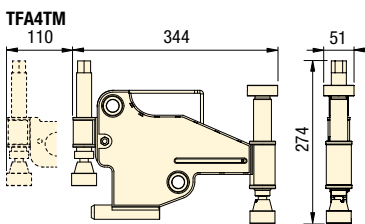

Model Number Tool Kit	Type*	Maximum Hook Force Per Tool (kN)	Maximum Aligning Distance (mm)	Maximum Operating Pressure (bar)	Flange Dimensions (mm)						Tool Weight (kg)	Kit Weight (kg)	Box/Case Dimensions (mm)	Tool Number
					A	B	C	D min	E	F min				
TFA4TMSTD	M	40	42	-	36-135	0-55	0-231	25	0-105	24	8,1	18,0	600x370x200	TFA4TM
TFA12TEMIN	H	240	65	510	129-178	110-241	0-167	45	87-125	62	19,3	28,4	640x540x165	TFA12TE
TFA15TEMIN	H	270	65	700	89-138	110-241	0-167	45	87-125	62	18,9	28,0	640x540x165	TFA15TE
TFA12TIMIN	H	240	65	-	129-178	113-241	0-167	45	87-125	62	21,9	31,0	585x900x160	TFA12TI
TFA15TIMIN	H	270	65	-	89-138	113-241	0-167	45	87-125	62	21,5	30,6	585x900x160	TFA15TI

* M = Mechanical
H = Hydraulic

▼ HP350DMIN



- HP-S , HP-D and HP-SD pump ranges are operable at all angles and are highly resistant to accidental spillage of hydraulic fluid. (certified)
- The Single-Port and Twin-Port Hand Pumps are also available with ATEX rating, which are certified for use in hazardous areas II 2G Ex h IIB T5 Gb, II 2D Ex h IIIC T100°C Db.

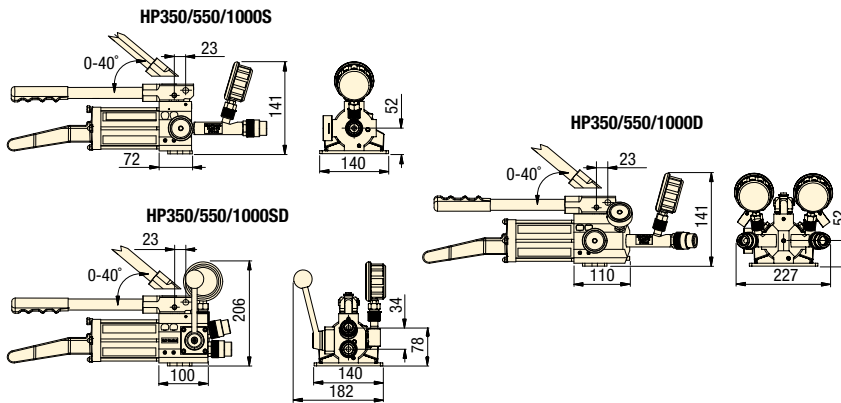

HP Series



HYDRAULIC SEALED
HAND PUMPS

Maximum Pressure Rating:

1st Stage: 13,8 bar
2nd Stage: 700 bar

Pump Type:

2-Speed



Pump Ratings

The Hydraulic Single Port, Twin Port and Double-Acting Hand-Pump (and hoses) are tailored for use with hydraulic equipment. Each pump's output is regulated to 700 bar and is delivered from threaded 3/8" NPT output ports. The pumps and hoses can be used with any 700 bar rated hydraulic equipment within their oil capacity specification. The HP range of hydraulic hand-pumps have been designed with a seal oil reservoir, which allows the pumps to be used in any orientation without the risk of oil spills or air contamination

700 BAR HOSES

AVAILABLE TO PURCHASE SEPARATELY

Model Number	Description
302701-01	HYDRAULIC HOSE 2M
302702-01	HYDRAULIC HOSE 4M
302705-01	HYDRAULIC HOSE 3M
302706-01	HYDRAULIC HOSE 5M
302707-01	HYDRAULIC HOSE 6M
1440008-01	ATEX HYDRAULIC HOSE 2M
1440013-01	ATEX HYDRAULIC HOSE 4M
1440014-01	ATEX HYDRAULIC HOSE 6M

Model Number Hand Pump Kit		Type*	Nominal Oil Capacity (cc)	Useable Oil Capacity (cc)	Oil Volume per Stroke (cc)		Max. Handle Effort (kgf)	Piston Stroke (mm)	Overall Length (mm)	Box Dimensions (mm)	Pump Weight (kg)	Kit Weight (kg)	Tool Number
Standard	ATEX				1st Stage	2nd Stage							
HP350SMIN	HP350SMINEX	SA, SP	350	300	3,62	0,77	33	18	554	250 x 180 x 600	4,4	4,9	HP350S
HP550SMIN	HP550SMINEX	SA, SP	550	580	3,62	0,77	25	18	643	250 x 180 x 700	5,1	5,9	HP550S
HP1000SMIN	HP1000SMINEX	SA, SP	1000	1110	3,62	0,77	21	18	867	250 x 180 x 900	6,1	7,1	HP1000S
HP350DMIN	HP350DMINEX	SA, TP	350	300	3,62	0,77	33	18	580	250 x 180 x 600	6,5	7,2	HP350D
HP550DMIN	HP550DMINEX	SA, TP	550	580	3,62	0,77	25	18	669	250 x 180 x 700	7,2	8,1	HP550D
HP1000DMIN	HP1000DMINEX	SA, TP	1000	1110	3,62	0,77	21	18	893	250 x 180 x 900	7,1	9,3	HP1000D
HP350SDMIN	-	DA	350	300	3,62	0,77	33	18	456	250 x 180 x 600	5,3	5,7	HP350SD
HP550SDMIN	-	DA	550	580	3,62	0,77	25	18	579	250 x 180 x 700	5,7	6,0	HP550SD
HP1000SDMIN	-	DA	1000	1110	3,62	0,77	31	18	769	250 x 180 x 900	5,9	6,3	HP1000SD

* SA = Single Acting DA = Double Acting
SP = Single Port TP = Twin Port

Enerpac Heavy Lifting Technology provides customers with tailored solutions, combining hydraulics, steel fabrication and electronic control technology. Global Leader providing best in class solutions for safe and precise positioning of heavy loads.

With more than 50 years supporting industrial markets, Enerpac has gained the unique and in-depth expertise that is respected by industrial professionals around the world. Across every continent, Enerpac's network of application engineers, authorized distributors and technical service centers can reach any location, and deliver innovative solutions, technical assistance and quality products.

Enerpac's complete line of standard and customized products and a unique systems approach offers the benefits of safety and efficiency to applications where high forces are required.

Whether constructing a signature bridge across a deep valley, lifting a national landmark for seismic retrofit or simultaneously testing hundreds of foundation pilings to support a new building, Enerpac will supply the hydraulic solutions to get the job done safely and efficiently.



Precision lift and position of heavy loads



Synchronous superlift and launch



Bridge lifting and launching



Jacking with high capacity precision control



Synchronous hoisting and load positioning



Incremental bridge lifting

















Transportation

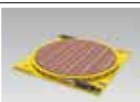

Special high tonnage cylinders for the Pioneering Spirit lifting beams

Heavy Lifting Technology - Section Overview

Capacity ton (kN)	Type and Capabilities	Series		Page
Flow: 0,27 - 2,10 l/min Power: 0,75 - 15 kW	Split-Flow Hydraulic Pumps Multiple outlets with equal flow for lifting and lowering	SFP		344 ▶
Flow: 2,1 - 8,0 l/min Power: 3,0 - 7,5 - 15 kW	Synchronous Lifting System, Pump-per-Point Provides industry leading speed and accuracy	EVOP		348 ▶
Flow: 0,75 - 4,80 l/min Power: 3,5 - 7,5 kW	Synchronous Lifting Systems, standard pumps The multi-functional synchronous lifting system	EVO		350 ▶
50 - 100 (500 - 1000)	Self-Locking Cube Jack Incremental lifting, automated mechanical locking	SCJ		352 ▶
50 - 200 (498 - 1995)	Climbing Jacks A simple solution to incremental lifting	BLS		356 ▶
125 - 750 (1250 - 7500)	Jack-Up Systems Synchronously lift, mechanically hold, incremental lifting	JS		358 ▶
15 - 1250 (147 - 12.250)	Heavy Lifting Strand Jacks High capacity precision control	HSL		360 ▶
55 - 225 (539 - 2204)	Synchronous Hoisting Systems - SyncHoist Precision positioning jacks	SHS SHAS		362 ▶
40 (400)	Mini-Lift Hydraulic Gantries Portable design with precision control	ML		364 ▶
1000 - 1100 (100 - 10.484)	Telescopic Hydraulic Gantries Precision lift and position of heavy loads	SL SBL		366 ▶
100 - 250 (860- 2500)	Skidding Systems The ideal jack and slide solution	LH HSK		368 ▶ 372 ▶
127 (1250) 25 - 50 m/hr	Electric Trolley System Synchronized travel	ETR		374 ▶
200 - 400 (2000- 4000)	Hydraulic Turntables Controlled rotation of heavy loads	ETT		376 ▶
60 (600) Speed: 3 - 1,5 km/hr	Self-Propelled Modular Transporters Hydraulic strength in a linear drive transport system	SPMT		377 ▶
–	Custom Heavy Lifting Solutions Solution Consultations, On-Demand Support	–		378 ▶ 380 ▶

▼ SFP414SW and SFP403SW (Gauges and retract valves not shown)



- 2, 4, 6 or 8 split-flow outlets
- Individual or simultaneously operation of valves, with advance/hold/retract function
- Joystick (manual) controlled or pendant (solenoid) controlled valves
- Flow per outlet ranging from 0,27 to 2,10 l/min at 700 bar
- For double- and single-acting cylinders
- Adjustable pressure relief valve per circuit
- Reservoir: 20, 40 or 150 litres
- All models include pressure gauges.

▼ Step-by-step stage lifting an old windmill using double-acting RR506 cylinders powered by a split-flow pump.



Multiple Outlets with Equal Flow for Lifting and Lowering



Typical Split-Flow Pump Applications

For lifting and lowering applications on multiple points, Split-Flow Pumps are a far better alternative than using independently operated pumps. Where synchronization of maximum 4% is acceptable, Split-Flow Pumps are a safe and economical solution.

The SFP-Series pumps feature both single and synchronized multiple outlet control either through joystick or pendant operation.

Application examples:

- Bridge deck lifting for bearing maintenance
- Stage lifting in construction and shipbuilding
- Skidding to move structures and buildings
- Levelling of constructions such as wind turbines.



Remote Control Pendant

Split-Flow pumps with solenoid valves include a remote pendant with selector switches for each individual outlet, allowing single or multiple cylinder operation.



High Pressure Hoses

Enerpac offers a complete line of high quality hydraulic hoses. To ensure the integrity of your system, specify only genuine Enerpac hydraulic hoses.

Split-Flow Hydraulic Pumps

SFP Series



Reservoir Capacity:

20 - 40 - 150 litres

Split-Flow Outlets:

2, 4, 6 and 8 outlets

Flow at Rated Pressure:

0,27 - 2,10 l/min

Motor Size:

0,75 - 15 kW

Maximum Operating Pressure:

700 bar

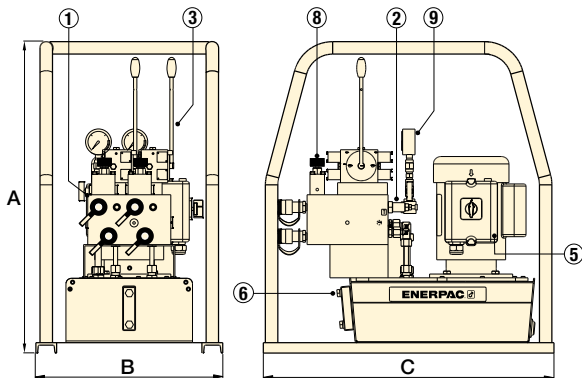

◀ SFP-Series with 20 litres reservoir (shown with 2 split-flow outlets)

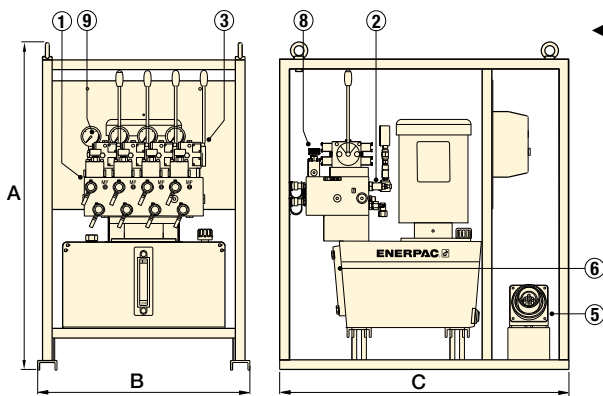

◀ SFP-Series with 40 litres reservoir (shown with 4 split-flow outlets)

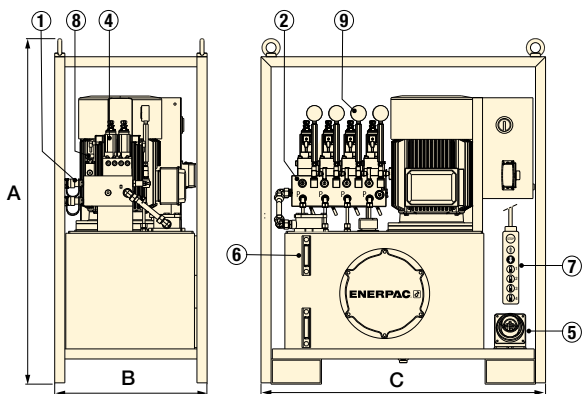

◀ SFP-Series with 150 litres reservoir (shown with 4 split-flow outlets)



Lifting Cylinders

For a complete line of Enerpac cylinders, see the Cylinder and Lifting Products in our catalogue.

Page: 5

- ① Manifold with split-flow outlets and CR400 couplers
- ② Adjustable pressure relief valve per circuit
- ③ Manual 4/3 control valves with joysticks
- ④ Solenoid 4/3 control valves (24 VDC)
- ⑤ Power socket
- ⑥ Oil sight gauge(s)
- ⑦ Remote control pendant with 5 m cord
- ⑧ Return flow control valve in each circuit
- ⑨ Hydraulic pressure gauge in each circuit

Number of Split-Flow Outlets	Usable Oil Capacity (litres)	Oil Flow per Outlet @ 700 bar (l/min)	Pump Model Number 4/3 Valve Operation Advance/Hold/Retract		Motor Size 400 V, 3ph 50 Hz (kW)	Dimensions (mm)			⚖️ (kg)
			Manual (Joystick)	24 V Solenoid (Pendant)		A	B	C	
2	20	0,27	SFP202MW	—	0,75	748	450	700	115
	40	0,30	SFP403MW	SFP403SW	2,2	1016	640	970	257
4	135	0,90	SFP409MW	SFP409SW	5,5	1356	605	1160	475
	135	1,40	SFP414MW	SFP414SW	7,5	1356	605	1160	490
	135	2,10	SFP421MW	SFP421SW	10	1356	605	1160	596
6	135	1,30	—	SFP613SW	10	1356	805	1200	562
8	40	0,30	—	SFP803SW	5,5	1163	830	1113	450
	135	1,30	—	SFP813SW	15	1356	805	1200	620



Motor Voltage

Motor voltage is specified by the last letter in the model number.

Other motor voltages are available from Enerpac. Change "W" in the model as follows for other options:

J = 460-480V, 3 ph, 50-60 Hz

G = 208-240V, 3 ph, 50-60 Hz

▼ SFP-Series Split-Flow Pump Kit Components



Connecting Split-Flow Pumps for more lift points and greater accuracy

- Control multiple Split-Flow Pumps with one control unit
- Pumps can be closer to the lifting points, requiring shorter hoses and increasing accuracy
- Synchronize all lift points to within 1,0 mm (0.04 inch)
- Network control boxes expand the number of lifting points by combining up to four split-flow pumps together, simplifying lifting operations by using a single operator station
- Plug and play synchronous lift upgrade kits limit initial investment and provide everyday flexibility to tailor the controls to the applications needs.



Split-Flow Pumps Kits

SFP-Series kits are customized from standard components to meet the needs of your unique applications. On the next page is the guide to help you choose the right components to upgrade or expand your equipment based on your application needs.

Contact your regional Enerpac representative / territory manager for support with your specific project.

Split-Flow Pump Network Kits

Split-Flow Pump Network Kits connect multiple Split-Flow Pumps under one control system.

Split-Flow Pump Synchro Kits

Split-Flow Pump Synchro Kits connect and electronically synchronize each lift point of a single Split-Flow Pump or multiple Split-Flow Pumps under one control system.



Junction Box

SFPKSS4 and **SFPKSS8** junction boxes consolidate the signals from pressure and stroke sensors, allowing the master control box to synchronize the lifting operation.



SFPKMN, Master Control Box

All SFP-Series Synchro Kits include a master control box to allow the operator to easily monitor and control a multi-point synchronized lift and adjust individual lift points as needed. All master control boxes feature an industrial grade touch screen and a user-friendly interface.



EVO-SC, Stroke Sensor Cables

Can be connected together for additional length. Ordered separately, requires one for each stroke sensor.

Model Number	Length (m)	Model Number	Length (m)
EVO-SC-6	6	EVO-SC-25	25



EVO-WSS, Wire Stroke Sensors

Provides stroke feedback to controls. Includes magnets for mounting. Ordered separately, requires one sensor for each

lifting point. Available in measuring range from 375 to 1000 mm.

Model Number	Range (mm)	Model Number	Range (mm)
EVO-WSS-375	375	EVO-WSS-1000	1000
EVO-WSS-500	500	-	-



Communication Cables

EVO-COMM-Series communication cables transfer information about the synchronized lift operation

from the master control panel to each of the connected split-flow pumps.

Model Number	Length (m)	Model Number	Length (m)
EVO-COMM-25	25	EVO-COMM-75	75
EVO-COMM-50	50	EVO-COMM-100	100

Split-Flow Pump Network Kits



Upgrading Split-Flow Pumps

To network multiple SFP-pumps together with standard function see drawing and table ①.

To upgrade a single SFP-pump to synchronous lift capability, see drawing and table ②.

To upgrade and network multiple SFP-pumps together with synchronous lift capabilities, see drawing and table ③.

SFP Series



Multiple Pumps in Network System:

1 - 4 pumps

Maximum Lifting Points:

32x cylinders

① Networked SFP-Pumps in Standard Operation

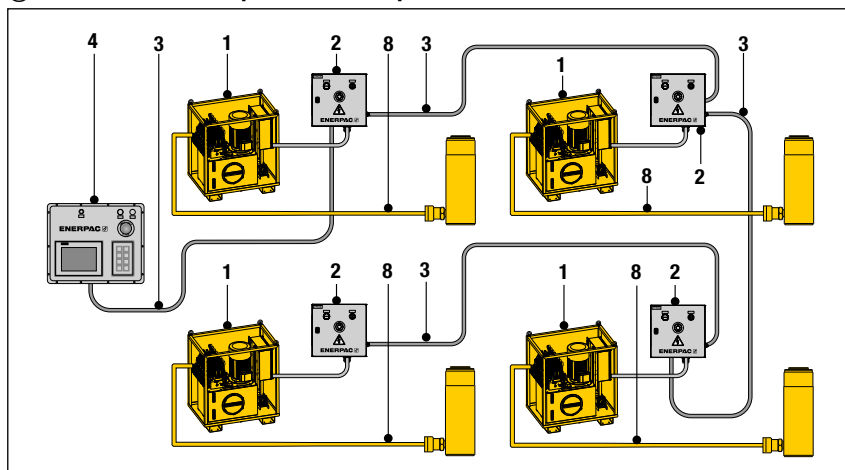

① Networked SFP-Pumps in Standard Operation

Nr.	Qty	Model Nr. & Description
1	4x	SFP...SW Pumps with solenoid valves
2	4x	SFPKSN Junction Box, 1x per pump
3	4x	SFPCOMM-25 Communication Cable, 1x per pump
4	1x	SFPKMN Master Control Box
8		HC-700-Series, Hydraulic Hoses

② Single SFP-Pump in Multiple-Point Synchronous Lifting Operation

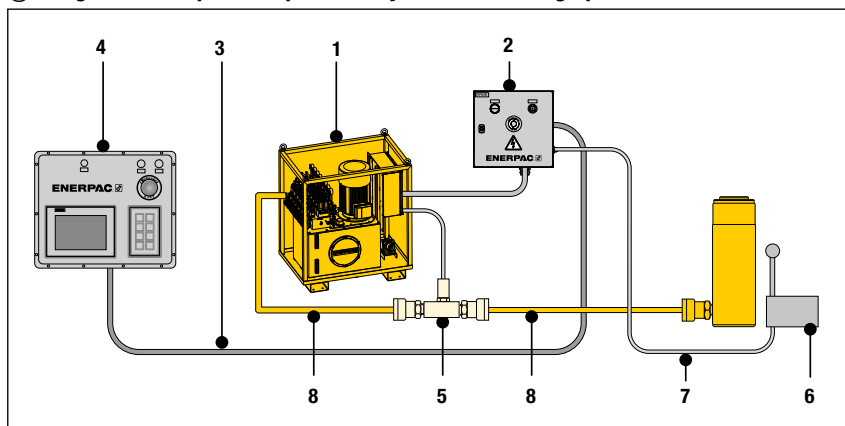

② Single SFP-Pump in Multiple-Point Synchronous Lifting Operation

Nr.	Qty	Model Nr. & Description
1	1x	SFP...SW Pump with solenoid valves
2	1x	SFPKSS4 Junction Box for 2-4 lifting points or SFPKSS8 for 6-8 lifting points
3	1x	SFPCOMM-25 Communication Cables
4	1x	SFPSSC Single Slave Control Box
5		SFPKPT Pressure Transducer Kit (1x per cylinder A-port)
6		EVO-WSS-XXX Stroke Sensor, 1x per cylinder
7		EVO-SC-25 Stroke Sensor Cable, 1x per cylinder
8		HC-700-Series, Hydraulic Hoses

③ Networked SFP-Pumps in Multiple-Point Synchronous Lifting Operation

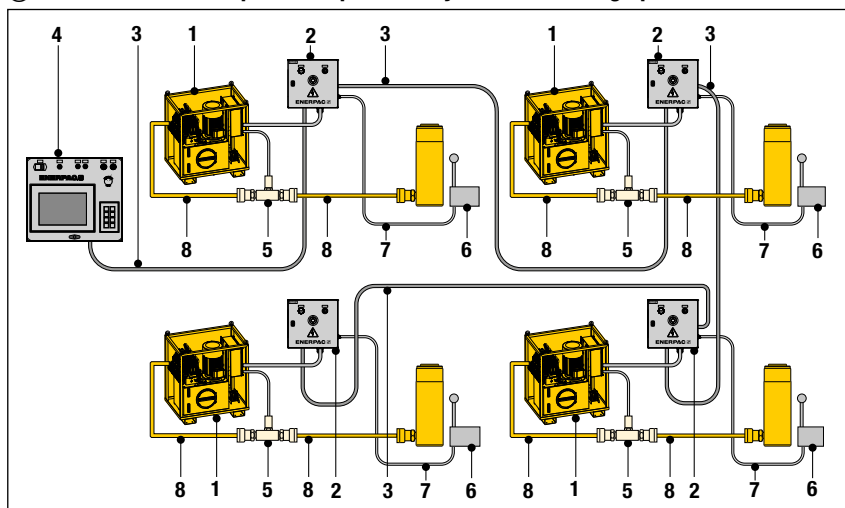

③ Networked SFP-Pumps in Multiple-Point Synchronous Lifting Operation

Nr.	Qty	Model Nr. & Description
1	4x	SFP...SW Pump with solenoid valves
2	4x	SFPKSS4 Junction Box, 1x per pump, for 2-4 lifting points or SFPKSS8 Junction Box for 6-8 lifting points
3	4x	EVO-COMM-XXX Communication Cable, 1x per pump
4	1x	EVOMASTER Master Control Box
5		SFPKPT Pressure Transducer Kit, 1x per cylinder A-port
6		EVO-WSS-XXX Stroke Sensor, 1x per cylinder
7		EVO-SC-25 Stroke Sensor Cable, 1x per cylinder
8		HC-700-Series, Hydraulic Hoses

▼ EVOP140150W Hydraulic Power Unit



- Lifting system controls multiple lifting points
- Each EVOP-Series pump (Pump-per-Point) controls only one lifting point, providing the best combination of high flow rate and exceptional accuracy
 - Ideal for high-tonnage cylinders, 300 to 1000-ton capacities
 - Increased lifting speeds for long stroke cylinders and repetitive operations such as with climbing jacks
 - Up to 8x lifting speed compared to similar methods
- Synchronization controlled via a variable frequency drive (VFD) on the motor, enables smoother operation and tight accuracy at high lifting speeds
- Standard control interface provides easy set-up and operation/selection of multiple lifting options
- Accuracy of up to 1,0 mm (0.040 inch) between leading and lagging cylinders
- Built-in warning and stop alarms for optimal safety.



◀ A 1200-ton electric mining shovel being separated using custom 500-ton RR-Series cylinders and a pump per point synchronous lift system.

Raising the speed limit on synchronized lifting operations



CLNC12 Network Controller

Easily monitor and control a multipoint synchronized lift. All network control boxes feature an industrial grade touch screen and a user-friendly interface. Same controller can be used to operate either SFP-Series Split-Flow Pumps or multifunctional EVO-Series lifting systems.



EVO-SC-25, Stroke Sensor Cable, 25 metres

Can be connected together for additional length. Ordered separately, requires one for each stroke sensor.



EVO-WSS, Wire Stroke Sensors

Provides stroke feedback to controls. Includes magnets for mounting. Ordered separately, requires one sensor for each

lifting point. Available in measuring range from 100 to 1250 mm.

Model Number	Range (mm)	Model Number	Range (mm)
EVO-WSS-100	100	EVO-WSS-750	750
EVO-WSS-125	125	EVO-WSS-1000	1000
EVO-WSS-375	375	EVO-WSS-1250	1250
EVO-WSS-500	500	-	-



Communication Cables

EVO-COMM-Series communication cables transfer information about the synchronized lift operation

from the network control panel to each of the connected hydraulic pumps.

Model Number	Length (m)	Model Number	Length (m)
EVO-COMM-25	25	EVO-COMM-75	75
EVO-COMM-50	50	EVO-COMM-100	100

Synchronous Lift System, Pump-per-Point



EVOP-Series Pumps

The Enerpac EVOP-Series (Pump-per-Point) synchronous lift system provides industry leading speed and accuracy for 700 bar lifting operations.

Safety: Stroke synchronization ensures level lift regardless of load distribution.

Lifting Speed: Improve lifting speed up to 8 times over traditional multi-point lifting systems. Save time on long stroke lifts and repetitive operations

Accuracy: Variable speed motor control allows accuracy down to 1,0 mm (0.040") between cylinders and smooth operation without the start and stop associated with opening and closing hydraulic valves.

EVOP Series



Lifting Points per Pump:

1x cylinder/pump

Reservoir Capacity:

40 - 150 litres

Flow at Rated Pressure:

2,1 - 8,0 l/min

Motor Size:

3,0 - 7,5 - 15 kW

Maximum Operating Pressure:

700 bar

Networked EVOP-Pumps in Multipoint Synchronous Lifting Set-Up

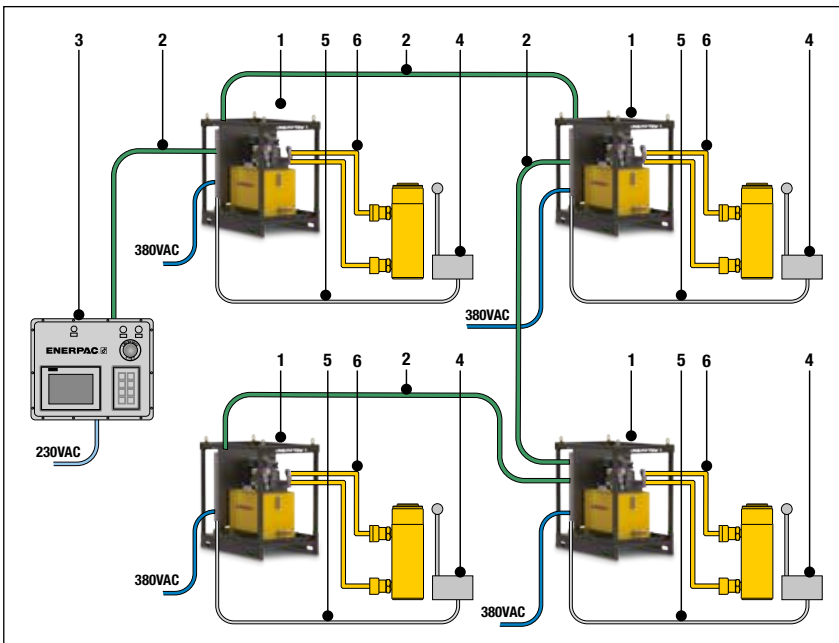

Networked EVOP-Pumps in Multipoint Synchronous Lifting Set-Up (with double-acting cylinders)

Nr.	Model Nr. & Description	Quantity
1	EVOP-Series Pump with Solenoid Valves	1x/cylinder
2	EVO-COMM-XXX Communication Cable	1x/pump
3	CLNC12 Network Control Box	1x/system
4	EVO-WSS-XXX Stroke Sensor	1x/cylinder
5	EVO-SC-25 Stroke Sensor Cable	1x/cylinder
6	HC700-Series Hydraulic Hoses	2x/cylinder

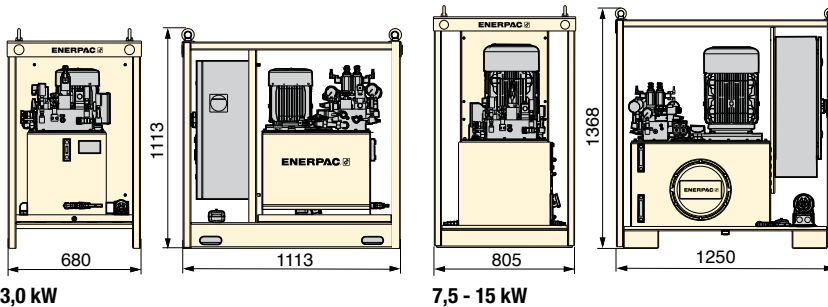

High-Tonnage Cylinders

The Enerpac High-Tonnage Cylinders are particularly suitable for (multipoint) lifting applications. Double-acting cylinders are recommended to take advantage of speed and time saving with EVOP-Series pumps.

Page: 44

EVOP-Series (Pump-per-Point)

Lifting Points per Pump (cylinder)	Reservoir Capacity (litres)	Oil Flow ¹⁾ (l/min)		Model Number ²⁾ 380 - 415 V, 3 phase, 50-60 Hz	Motor Size (kW)	Motor Weight (kg)
		(< 120 bar)	(> 120 bar)			
1x	40	11,1	2,1	EVOP12140W	3,0	310
1x	150	13,0	4,0	EVOP140150W	7,5	490
1x	150	17,0	8,0	EVOP180150W	15	506

¹⁾ First stage high oil flow only available in manual control mode.

²⁾ For 440-480 Volt - 3ph - 60 Hz change suffix "W" into "J". Example: **EVOP140150J**.



BLS-Series Climbing Jacks

Climbing Jacks overcome the usual limitation of lift height imposed by the jack's plunger stroke length. Large objects, such as oil tanks, can be lifted, held and lowered for maintenance without sending for a crane.

Page: 356

▼ EVO 841460W



- **Modular lifting pumps to control 4, 8 or 12 lifting points**
- **Can be connected to single- or double-acting cylinders with the same or different lifting capacities**
- **PLC-controlled system with integrated 700 bar hydraulic power unit and 250 litres reservoir**
- **Network capability to link up to 4 EVO-units (HPUs) to a separate network controller via wireless control**
- **Intuitive user interface providing easy set up, control and navigation**
- **Data storage and recording capabilities**
- **Variable frequency drive motor (VFDM) and PLC for precise synchronization and oil flow control.**



The multi-functional synchronous lifting systems



EVO-System Work Modes

The application possibilities are infinite with the standard EVO-System, powering interlinked hydraulic cylinders – single or double-acting, push or pull, stage lift, hollow plunger or lock nut cylinders. The EVO-System has 9 work modes. The operator can navigate to any of these menus:

1. Manual
2. Pre-Load
3. Automatic
4. Retract Fast
5. Depressurize
6. Tilting
7. Stage Lift
8. Weighing *
9. Center of Gravity determination *

* Available in the **EVO-W-models**.



Typical Synchronous Lifting Applications

- Bridge lifting and repositioning
- Bridge launching
- Bridge maintenance
- Incremental launching and box jacking
- Lifting and lowering of heavy equipment
- Lifting, lowering, levelling and weighing of heavy structures and buildings
- Structural and pile testing
- Lifting and weighing of oil platforms
- Foundation levelling of onshore and offshore wind turbines
- De-propping/load transfer from temporary steel work
- Foundation shoring.

◀ *The superlifting and launch of a 43.000-ton floating oil production system in Malaysia for the Gumusut-Kakap offshore field has set high benchmarks for safety through its use of sophisticated EVO-Series synchronous hydraulics to lift, balance, weigh and smoothly launch massive resource structures.*



Benefits of the EVO-Series System

Precise control of multiple lift points

- Comprehensive understanding and management of a lifting operation from a central control system improves safety and operational productivity.
- Programmable synchronized lifting.
- Automatic stop at pre-set cylinder stroke or load limit.

Safe and efficient movement of loads

- System secured with warning and stop features to realize optimal safety.

High accuracy

- Variable frequency drive (VDFM) and PLC for precise synchronization and control of oil flow, stroke and speed.
- Depending the cylinder capacities used, an accuracy of 1,0 mm between lifting points is achieved.

Ease of operation

- User friendly interface: visual screens, icons, symbols and color coding.
- A single operator controls the entire operation.

Monitoring and Data Recording

- Displays data of the operation.
- Data recording at user-defined intervals.
- Data storage and read-out for reporting.

Network capability

- Ethernet IP protocol for communication between hydraulic power units, allow easy "plug and play".

EVO-W Weighing System

Weighing applications with 1% accuracy

- Includes calibrated sensors and auto-calibration of external load cells.
- Center of gravity determination functionality.
- Parameters for "waiting time for stabilization" and "number of cycles".

Global standardized system

- Enerpac global coverage ensures local support.

EVO Series



Number of Lifting Points:

4 - 8 -12 (up to 48)

Reservoir Capacity:

250 litres

Flow at Rated Pressure:

0,75 - 4,80 l/min

Motor Size:

3,50 - 7,50 kW

Maximum Operating Pressure:

700 bar



Stroke Sensors and Cables

Optional accessories required for each lifting point and stroke sensor.

Page: **348**

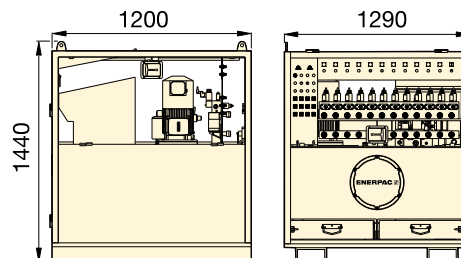

CLNC12 Network Controller

Required to link up to 4 standard EVO-pumps together to achieve a maximum of 48 lifting points. Contact Enerpac for more information.

EVO-Series (Standard)

Lifting Points	Variable Oil Flow at 50 Hz ¹⁾ (l/min)		Model Number ²⁾ 380-415 V, 3ph, 50-60Hz	Usable Oil Capacity (litres)	Motor Size (kW)	Motor Speed ⁴⁾	(kg)
	(< 125 bar)	(> 125 bar)					
4	4,0 - 13,3	0,75 - 2,51	EVO421380	250	3,5	VFDM	910
4	4,0 - 13,3	0,75 - 2,51	EVO421380 W³⁾	250	3,5	VFDM	910
4	4,7 - 15,6	1,44 - 4,80	EVO440380	250	7,5	VFDM	1005
4	4,7 - 15,6	1,44 - 4,80	EVO440380 W³⁾	250	7,5	VFDM	1005
8	4,0 - 13,3	0,75 - 2,51	EVO821380	250	3,5	VFDM	910
8	4,0 - 13,3	0,75 - 2,51	EVO821380 W³⁾	250	3,5	VFDM	910
8	4,7 - 15,6	1,44 - 4,80	EVO840380	250	7,5	VFDM	910
8	4,7 - 15,6	1,44 - 4,80	EVO840380 W³⁾	250	7,5	VFDM	910
12	4,0 - 13,3	0,75 - 2,51	EVO1221380	250	3,5	VFDM	920
12	4,0 - 13,3	0,75 - 2,51	EVO1221380 W³⁾	250	3,5	VFDM	920
12	4,7 - 15,6	1,44 - 4,80	EVO1240380	250	7,5	VFDM	1025
12	4,7 - 15,6	1,44 - 4,80	EVO1240380 W³⁾	250	7,5	VFDM	1025

¹⁾ Oil flow will be approximately 6/5 of these values at 60 Hz.

²⁾ For 460-480 VAC, 3 phase, 50-60 Hz change 380 in model number into 460. Example **EVO421460**.

³⁾ Model numbers with suffix **W** are pumps for weighing systems. ⁴⁾ VFDM = Variable Frequency Drive 15-50 Hz.

▼ Precision levelling caisson pier box: 3 EVO-Systems connected with 32 jacks lowered the 1100 ton bascule pier box.



▼ SCJ50, Enerpac Self-Locking Cube Jack



- System is automatically mechanically locked after the lifting or lowering stroke
- Self-aligning steel cribbing blocks save time, improve side load, and eliminate the need for wooden cribbing materials
- Jobs are completed more efficiently due to simplified operation sequence with 50% less cycles than climbing jacks
- End block with adjustable swivel saddle allows fine adjustment during set-up: 50 mm screw extension
- Can be operated with Enerpac's 700 bar hydraulic power units
- Lloyds witness tested to 125% of maximum working load.

Incremental lifting system with automated mechanical locking



Why use Self-Locking Cube Jacks?

The Self-Locking Cube Jack is a safer, more efficient alternative to the jack-and-pack method with wooden cribbing. The Self-Locking Cube Jack is derived from the proven Enerpac Jack-up System.

The Cube Jack has a small footprint and is useable in confined spaces, providing heavy lift contractors with a stable lift up to 3 metres. The cribbing blocks are lightweight and can be handled manually.



Markets & Applications

Applications with a minimum starting height of 494 or 558 mm and requirement to lift up to

2067 or 3006 mm.

- Power Generation - transformer jacking
- Mining - equipment maintenance
- Heavy Transport - vehicle unloading
- Oil & Gas - module jacking
- Construction - bridge jacking
- Industrial Movers - lifting, lowering and levelling of heavy equipment.



◀ Completed in just over one hour, the 160 ton 50 x 7 meters steel racking system was lifted synchronously to a height of 2,2 meters using 16 Enerpac SCJ50 Cube Jacks powered by a single SFP-Series Split-Flow Pump. Lifting large racking systems can be hazardous, complex and difficult involving forklift trucks and chain blocks. Photo by courtesy of PHL Hydraulics Ireland Ltd.

▼ Forklift tabs on Cube Jacks for easy transportation and positioning with a pallet truck. See dimensions D and I to select the right pallet truck size.



Self-Locking Cube Jack



Self-Locking Cube Jack

Easy-to-use, compact and portable jacking system that utilizes base lifting frames and self-aligning, lightweight steel cribbing blocks, instead of wooden cribbing materials.

Operation is simple:

1. Connect the Cube Jacks to the Enerpac Split-Flow Pump and select lifting mode on each base lifting frame.
2. Insert a cribbing block and actuate the Cube Jack until the cribbing block engages the lock mechanism.
3. Retract the jack and repeat the process until the desired lifting height is reached. For the lowering operation select lowering mode on each base lifting frame and reverse the process.

The Cube Jack End Block is equipped with an adjustable saddle for initial alignment with the load.

All controls except for the main directional valve, which is on the hydraulic power unit, are included on the Cube Jack.

Manual cribbing block insertion

Cribbing blocks are easily managed by hand and the Cube Jack includes integrated fork pockets and lifting rings for effortless positioning.

Synchronous Lifting & Lowering

Enerpac recommends using the SFP-Series Split-Flow Pumps with multiple outlets with equal oil flow. For lifting and lowering applications on multiple points, Split-Flow Pumps are a far better alternative than using separately operated pumps.

If synchronous lifting & lowering is required, the SFP-Series Pumps can be configured to accommodate stroke sensors and provide accurate computer controlled lifting function.

SCJ Series



Capacity Per Cube Jack:

500 - 1000 kN

Maximum Lifting Height:

2067 - 3006 mm

Maximum Operating Pressure:

700 bar

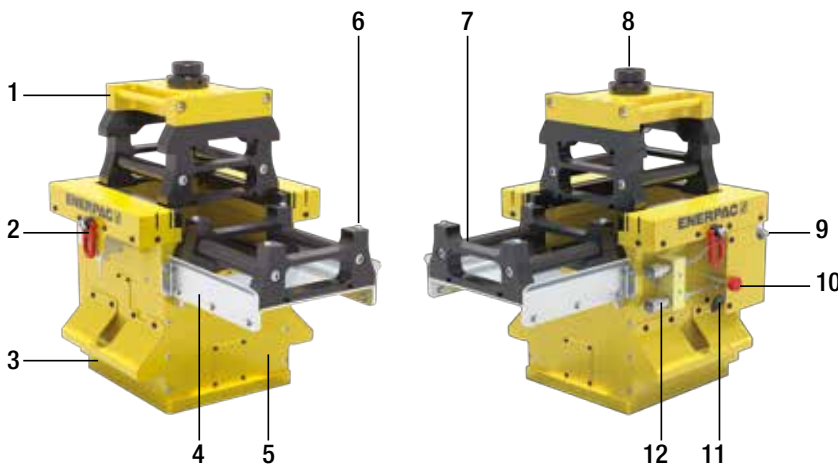

Self-Locking Cube Jack

- | | |
|---------------------------------|---|
| 1 End block with tilting saddle | 7 Steel cribbing blocks |
| 2 Eye-bolts for hoisting | 8 Adjustable tilting saddle |
| 3 Forklift tabs | 9 Flow control |
| 4 Removable insert table | 10 Mode locking pin |
| 5 Cube Jack base frame | 11 Mode selector lever |
| 6 Locating pins | 12 Hydraulic connections
(Advance / Retract) |

▼ Cube Jack close-up of lifting and lowering valving mode and lock handle.



▼ Optional wire stroke sensor can provide stroke feedback to pump control.



▼ SCJ100, Enerpac Self-Locking Cube Jack



Incremental lifting system with automated mechanical locking



Transport Frame

Provided with purchase of each Cube Jack. Provides storage and transport for base unit, end block, and all included cribbing blocks.



Lightweight Cribbing Blocks

Provided with purchase of each Cube Jack. Cribbing blocks can be manually inserted into the Cube Jack by one person. Spare cribbing blocks can be ordered separately.

Included with the Cube Jack are:

- Cube Jack Basic Unit
- End Block with adjustable swivel saddle
- Multiple cribbing blocks: **11x on SCJ50**
18x on SCJ100
- Transportation Frame
- Cribbing blocks can be manually inserted into the Cube Jack by one person.

Description	Model Nr.
1x Cribbing Block, 50 ton	SCJ5B
1x Cribbing Block, 100 ton	SCJ10B



Split-Flow Pumps

Enerpac recommend to use the **SFP-Series Pumps** with multiple outlets with equal oil flow.

For lifting and lowering applications on multiple points, Split-Flow Pumps are a far better alternative than using separately operated pumps.



◀ Heat exchanger maintenance job on the piping and condensers at a refinery using a combination of Enerpac Heavy Lifting Technology: SCJ-Series Cube Jacks, the ETT-Series Hydraulic Turntable and LH-Series Low-Height Skidding Systems.

Self-Locking Cube Jacks

Lifting Capacity per Base Unit ton (kN)	Lifting Stroke (mm)	Model Number	Maximum Sideload at full extension	Maximum Pump Oil Flow Rate (l/min)	Oil Capacity per Base Unit (cm ³)	
					Advance	Retract
50 (500)	156	SCJ50	1,5%	0,9	1229	623
100 (1000)	156	SCJ100	1,5%	1,8	2500	1400

Self-Locking Cube Jack and Accessories

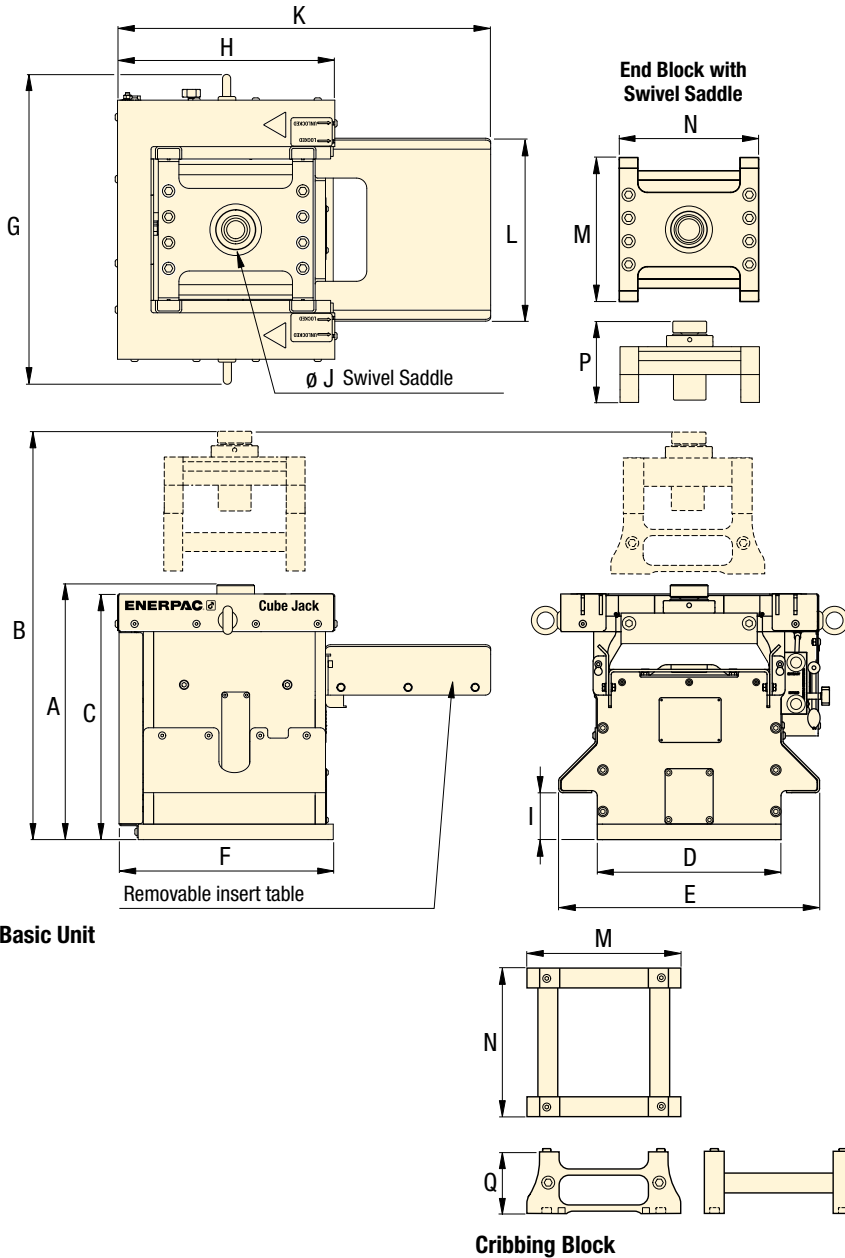

SCJ Series



Capacity Per Cube Jack:

500 - 1000 kN

Maximum Lifting Height:

2067 - 3006 mm

Maximum Operating Pressure:

700 bar

▼ Typical set-up with 4 Self-Locking Cube Jacks and cribbing blocks in a Factory Acceptance Test (FAT). Enerpac recommends to power the Cube Jack using SFP-Series Split-Flow Pump.



Base Unit		End Block		Cribbing Block		Transport Frame *	
Model Number	(kg)	Model Number	(kg)	Model Number	(kg)	Model Number	(kg)
SCJ50	360	SCJ5EB	40	SCJ5B	16	SCJ5F	110
SCJ100	820	SCJ10EB	100	SCJ10B	23,5	SCJ10F	250

Dimensions (mm)																	Model Number
A	B	C	D	E	F	G	H	I	J	K	L	M	N	Min. P	Max. P	Q	
494	2067	476	356	505	443	556	428	91	125	726	351	300	310	175	225	125	SCJ50
558	3006	526	506	655	636	772	598	101	170	1046	504	450	460	189	239	125	SCJ100

* Dimensions Transport Frame L x W x H: **SCF5F:** 920 x 850 x 860 mm
SCF10F: 1600 x 1200 x 1500 mm

▼ BLS1006



- Climbing jacks include integral tilt saddles with maximum tilt angles up to 5 degree
- Large base plate with anti-rotation rod for stability and safety
- Built-in safety valve prevents accidental over-pressurization
- Ideal in combination with the stage lift work mode of the EVO-Series synchronous lifting system
- Baked enamel finish for increased corrosion resistance
- CR400 couplers included on all models.

▼ Synchronous Stage Lifting: 48 double-acting jacks (25 and 50 ton) are networked in to a 16 points synchronous system to lift this 50 metres long, 1000 ton building up to a height of 2,5 metres to construct a new floor level.



A Simple Solution to Incremental Lifting



Lifting Height

Climbing Jacks overcome the usual limitation of lifting height imposed by the cylinder's plunger stroke length. Large objects, such as oil tanks, can be lifted, held and lowered for maintenance without sending for a crane.



Split-Flow Pumps

SFP-Series Split-Flow Pumps with multiple outlets with equal oil flow. For lifting and lowering applications on multiple points

Split-Flow Pumps are a far better alternative than using separately operated pumps.

Page: 344



Synchronous Lifting System

The standard EVO-Series System is ideal for stage lifting, powering interlinked hydraulic cylinders.

The EVO-system has 9 work modes including the stage lift work mode.

Page: 350



Jack-Up Systems

For incremental lifting with higher lifting capacities and up to 20 m lifting height, see our JS-Series Jack-Up Systems.

Page: 358

Cylinder Capacity	Stroke	Model Number	Max. Cylinder Capacity (kN)	
			Push	Pull
ton	(mm)			
50	150	BLS506	498	103
95	161	BLS1006	933	435
140	151	BLS1506	1386	668
200	151	BLS2006	1995	1017

Double-Acting Climbing Jacks



◀ Typical stage-lift application using a custom built Enerpac system to lift the 360 ton Akkerwinde wooden bridge in the Netherlands.

BLS Series



Capacity per Lifting Point:

50 - 200 ton

Stroke per Stage:

150 - 161 mm

Maximum Operating Pressure:

700 bar

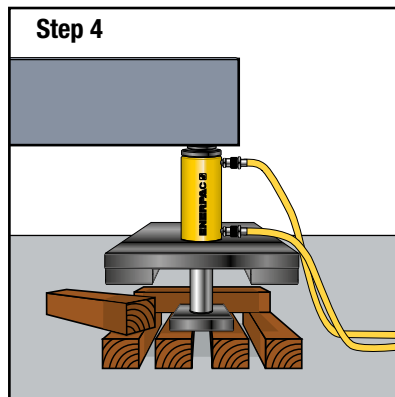
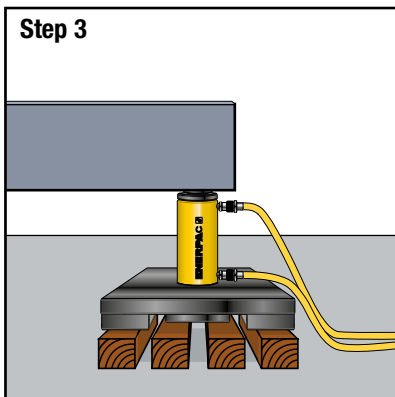
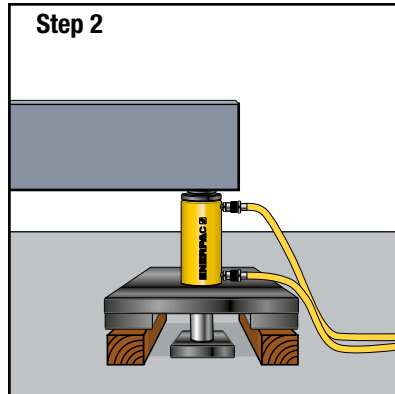
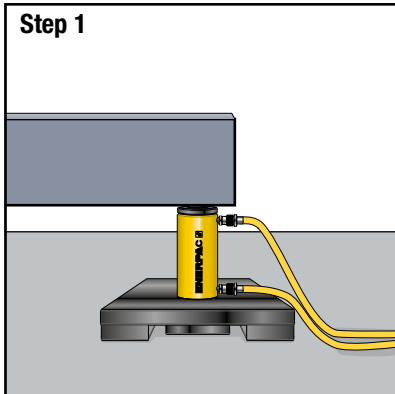

▲ Stage Lifting Sequence

Step 1: The climbing jack is placed on a solid support under the load (retracted plunger).

Step 2: Plunger extends, lifting the load and giving clearance to insert two outer blocks under the spreading plate.

Step 3: Plunger retracts, giving clearance to position the central blocks which will support the plunger plate for the next extension.

Step 4: Plunger extends, lifting the load, giving clearance to insert two new blocks, placed crosswise under the spreading plate.

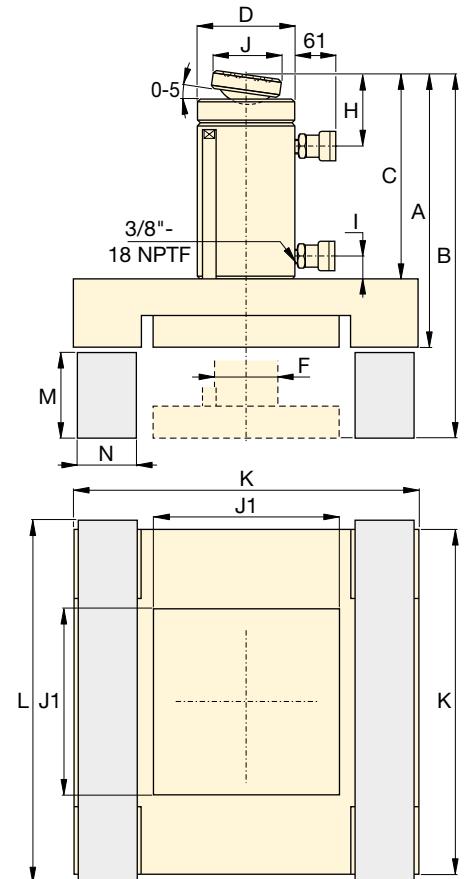

Cylinder Effective Area (cm ²)		Oil Capacity (cm ³)		Dimensions (mm)										Cribbing Blocks * and Dimensions (mm)			Model Number		
Push	Pull	Push	Pull	A	B	C	D	F	H	I	J	J1	K	Material	L	M	N	(kg)	
71,2	21,5	1111	335	406	556	318	127	79	56	36	50	240	515	Azobe	565	140	120	170	BLS506
133,3	62,2	2238	1045	445	606	343	177	95	76	24	71	330	670	Wood	720	150	160	315	BLS1006
198,1	95,4	3090	1488	472	624	370	203	114	94	39	130	230	475	Solid Aluminium or Steel	500	140	115	322	BLS1506
285,6	145,6	4332	2209	510	661	387	248	133	102	37	130	270	550		575	140	135	373	BLS2006

* Cribbing blocks are not supplied by Enerpac.

▼ JS125, JS250, JS500, JS750, Enerpac Jack-Up System (one lifting tower shown)



- Self-contained hydraulics in each jack-up unit for uncluttered work area
- Synchronously lift loads with multiple jack-up units. The most common system set-up includes 4 jack-up units
- Lifting barrels are stacked together to mechanically hold the load
- Up to 5% side load capacity depending on lifting height
- Computer controls for operating the jack-up system with automatic and manual lifting settings.

Incremental Lifting System – Synchronously Lift and Mechanically Hold



Typical Applications

- Bridge maintenance
- Lifting and lowering of heavy equipment
- Lifting, lowering and levelling of heavy structures and buildings
- De-propping/load transfer from temporary steel work.



Computer Controls

- Enerpac Jack-up Systems provide precision control suitable for many demanding lifting/lowering applications. The comprehensive self-contained design features simple to use software.
- Automatic synchronization of multiple networked lift points.
 - Overload and stroke alarms
 - Emergency stop switch at jack-up units and controls.

▼ Enerpac has been awarded a contract by Burkhalter to extend the height of Enerpac's 2000 ton (500 ton per tower) jack-up system from 20m to 36m for future projects.



▼ Enerpac Jack-Up System lifts 1500 ton span on Fore River Bridge.



▼ Undecking an 1500 ton Electric Rope Shovel in a Copper Mine with a JS500 Jack-Up System for bearing inspection and maintenance.



Enerpac Jack-Up Systems



Enerpac Jack Up Systems

The jack up system is a custom developed multi-point lifting system. A typical system setup includes four jack up units positioned under each corner of a load.

Example: A four unit setup with JS250 has a lifting capacity of 1000 ton (250 ton per unit). The lifting frame of a jack up unit contains four hydraulic lifting cylinders, one in each corner, which lift the load using the stacked steel barrels.

A load is lifted in increments as barrels are slid into the system, lifted, and stacked; forming 'lifting towers'. A jack up system is operated and controlled by a computer control unit.

Each unit's lifting and lowering operations occur simultaneously; the computer control unit's synchronous technology maintains the balance of the load.

JS Series



Capacity Per Lifting Tower:

125 - 750 ton

Lifting Height:

6 - 20 metres

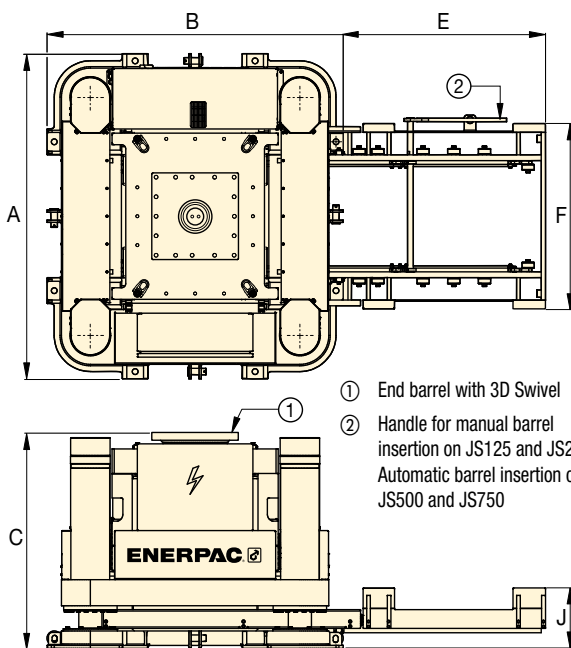

Jack-Up System (JS)

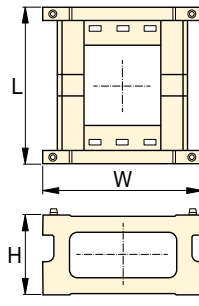

Steel Barrel (BLJS)

Steel Barrels

For use with Jack-Up System	Barrel Set Model Number	Number of Barrels per Set	Barrel Dimensions (mm)			Weight per Barrel (kg)
			L	W	H	
JS125	BLJS125	4	600	600	300	105
JS250	BLJS250	4	1150	1150	500	360
JS500	BLJS500	4	1700	1700	700	950
JS750	BLJS750	4	2300	2300	1000	2350

Jack-Up Systems

Capacity per Tower		Model Number	Maximum Sideload	Maximum Lifting Speed (m/hr)	Base Frame Dimensions (mm)			Barrel Loading System (mm)			Electric Power Pack (kW)	Weight per Jack-Up Unit * (kg)	Weight End Barrel (3D Swivel) (kg)
ton	kN				A	B	C	E	F	J			
125	1250	JS125	3% @ 6m	5	1200	1100	955	750	700	205	8,8	2400	570
250	2500	JS250	3% @ 10m	4	2250	2050	1475	1400	1341	418	15	7500	2400
500	5000	JS500	4% @ 15m	4	2800	2300	1700	1980	1771	458	30	13.750	3850
750	7500	JS750	5% @ 20m	4	3670	3250	2375	2850	2495	744	30	24.000	9000

* Weight per jack-up tower, excluding end barrel or barrel sets.



Jack-up System Smart Box

The **Smart Box SBJS-V4** is Enerpac's proprietary control platform. It allows an operator to control up to 8 jack up towers simultaneously with one **SBLT1** standard laptop.

- Single operator control from a central location provides safe and reliable operation
- Synchronous lift /lower and load control between the lifting positions
- Automatic lifting and lowering cycles
- Displays individual and accumulative stroke/load
- Simple graphical user interface.



Adjustable Top Barrel

Includes double-acting lock nut cylinder with swivel saddle. Cylinder can be extended to contact the load. Provides ability to adjust starting height of each leg, ensuring safe and stable lifting. Must be operated with separate pump.



Trolleys & Skid Tracks

Allows horizontal travel of jack-up systems.

▼ Shown: HSL50006 Strand Jack



- Precision control of synchronous lifting and lowering
- Can be controlled by a single operator from a central location for increased safety
- Automated locking - unlocking operation
- Two strand sizes: 15,7 mm and 18 mm (0.62 and 0.71 inch)
- Telescopic strand guide pipes prevent bird caging
- Internal components are coated with Lunac, an anti-corrosion coating, making it suitable for marine environments
- Lifting anchor included with all strand jacks
- Lloyd's witness tested to 125% of maximum working load.

▼ HSL85007 Strand Jack System used on Enerpac custom Self Erecting Tower.



High Capacity Precision Control



Heavy Lifting Strand Jacks

Enerpac strand jacks are the strand jacks of choice for customers seeking precise synchronous control with heavy-lifting capacity in an economical, compact, and reliable foot print.

Enerpac strand jacks are powered by electrical or diesel driven hydraulic power packs and controlled by Enerpac's proprietary SCC-Smart Cylinder Control System to ensure full control of lifting and lowering operations.

Enerpac continually improves reliability, durability, and safety of their strand jacks, making them an industry standard for heavy lifting.

▼ Enerpac's SCC-Smart Cylinder Control System simplifies synchronous operation with intuitive controls and a user-friendly graphical interface.



Heavy Lifting Strand Jacks



Strand Jacks

A strand jack can be considered a linear winch. In a strand jack, a bundle of steel strands are guided through a main "lifting" jack.

Above and below the cylinder are anchor systems with wedges that grip the strand bundle simultaneously. Lifting and lowering a load is achieved by hydraulically controlling the main jack and both mini jacks alternately.

In the case of system pressure loss, the wedges are mechanically closed automatically, holding the suspended load in place.

Today strand jacks are widely recognized as the most sophisticated heavy lifting solution. They are used all over the world to erect bridges, load out offshore structures, and lift/lower heavy loads where the use of conventional cranes is neither economical nor practical.

HSL Series



Capacity:
15 - 1250 ton

Stroke:
250 - 600 mm

Maximum Operating Pressure:
350 bar

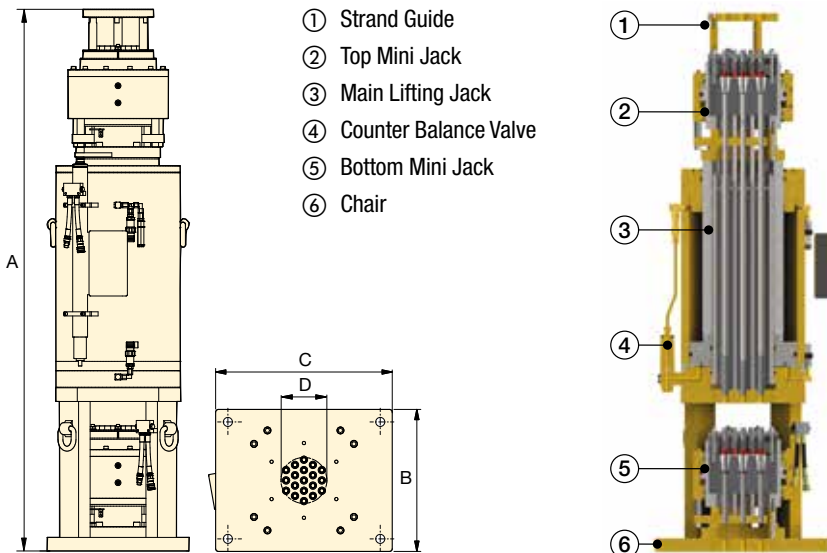

▼ Strand Jack Accessories

Contact Enerpac for assistance at enerpac.com/contact-us



SLPP-Series Hydraulic Power Packs

Enerpac offers a comprehensive range of hydraulic power packs that are optimized for use with their industry leading heavy lifting strand jacks.



SG-Series Strand Guides

Provides a guide for the strand as a strand jack lifts the load.



SR-Series Strand Recoilers

Passively pays in or pays out strands while jacking and lowering.



SD1 Strand Dispenser

Essential to safely unbundle a new strand coil.



Lifting Anchor

Each Strand Jack includes a lifting anchor for attaching strand to the load.

Strand Diameter mm (inch)	Capacity *		Model Number	Number of Strands	Stroke (mm)	Dimensions (mm)				Weight (kg)
	ton	(kN)				A	B	C	D	
15,7 (.62)	30	(300)	HSL3006	3	480	1851	350	500	59	500
	70	(700)	HSL7006	7	480	1915	360	575	93	640
	200	(2000)	HSL20006	19	480	1992	522	650	169	1300
	300	(3000)	HSL30006	31	480	2046	673	673	216	2180
	500	(5000)	HSL50006	48	480	2136	733	733	273	3150
18 (.71)	15	(150)	HSL1507	1	250	1242	220	220	20	100
	45	(450)	HSL4507	3	480	1728	350	500	73	500
	60	(600)	HSL6007	4	480	1752	400	625	88	650
	100	(1000)	HSL10007	7	480	1926	408	625	116	850
	200	(2000)	HSL20007	12	480	2001	522	650	165	1400
	300	(3000)	HSL30007	19	480	2055	673	673	210	2180
	450	(4500)	HSL45007	31	480	2223	733	733	272	3050
	650	(6500)	HSL65007	43	480	2237	850	850	351	3950
	850	(8500)	HSL85007	55	480	2402	900	900	364	5000
	1000	(10.000)	HSL100007	66	480	2558	1092	1092	436	7650
1250	(12.500)	HSL125007	84	600	2658	1100	1100	458	8300	

* Capacity is based on 2,5 minimum safety factor over strand breaking load.

▼ SHS-Series 4-Point SyncHoist System



- High precision load manoeuvring, vertically and horizontally – using one crane
- Reduces the risk of damage from oscillations of wire rope due to crane joggling and sudden starts/stops
- Vastly improving worker safety, operating speed and control
- Weather conditions play less critical role
- PLC-controlled hydraulics turn lifting into high accuracy hoisting and load positioning system
- Double-acting push/pull cylinders with load holding valves for added safety in case of hose rupture or coupler damage
- Cost reduction compared to conventional load positioning methods.

Options for system management & control:

- Manual control: system warning functions
- Automatic control: fully PLC-monitored system with programmable functions using touch screen and system warning functions
- SHAS-Series: Wireless control – self-contained hydraulics with hand-held control. Integrated PLC-controlled hydraulics in each lifting device – no need for external powerpack and hydraulic hoses.

▼ Bridge segments are hoisted from the ground, being positioned with a 4-point SyncHoist system with fully monitored cylinders.



▼ Rigging engineers used the SyncHoist system to precisely monitor and adjust each lifting point independently, or together in a synchronized manner to position the 1140 ton nuclear plant module.



Accurate Hoisting and Load Positioning Enhancing a Crane's Capability



Synchronous Hoisting

Enerpac SyncHoist is a unique crane product for below-the-hook positioning of heavy loads that require precision placement. The SyncHoist system may reduce the number of cranes needed and reduce the costs of multiple picks.

Functions

- High precision horizontal and vertical load positioning
- Pre-programmed positioning, tilting and aligning.

Applications

- Positioning of rotor, stator and propeller blades of wind turbines
- Positioning of roof sections, concrete elements, steel structures
- Positioning of turbines, transformers, fuel rods
- Precise machinery loading, mill rod changes, bearing changes
- Precise positioning of pipe lines, blow out valves
- Positioning and aligning of ship segments prior to assembly.

▼ Offshore wind turbine base foundations installed with a wireless SHAS-SyncHoist System to ensure the foundation remained vertical during lowering and positioning.



SyncHoist - High Precision Load Positioning



What is SyncHoist?

Enerpac SyncHoist is a hydraulically operated auxiliary attachment for high precision load positioning for cranes.

The automatic version with PLC-controlled hydraulic pump monitors and guides the powerful double-acting push-pull cylinders integrated into the lifting points above the load. The SyncHoist system can be used for pre-programmed positioning, tilting and aligning of loads.

- Patented system
- Complete system tested in compliance with European lifting directive and safety requirements

SyncHoist improves safety, operating speed and control of load movement

Geometric positioning of heavy loads in a horizontal and vertical plane are frequently done using more than one crane.

Synchronising movements between cranes are difficult and risky. The lifting inaccuracy can result in damage to the load and support structures and puts workers at risks.

The SyncHoist system can be used for controlled hydraulic horizontal and vertical material handling.

System management and control

Contact Enerpac for the following options, or other customised stroke, capacity and control configurations.

1. Manual control

- Valves with manual levers
- Warnings for thermal motor protection
- Visual check: oil level, filter indicator.

2. Automatic control

- Load and stroke monitoring, and stroke control
- PLC-control and touch screen
- Solenoid valves with pendant
- Pre-programmable motions and data recording
- System warnings for:
 - maximum cylinder load control setting
 - stroke and position control
 - thermal motor protection
 - oil level and filter indicator.

Autonomous SHAS-wireless system

- Wireless remote control
- Only one electric power connection per lifting point
- Integrated hydraulics, PLC and controls
- No need for hydraulic hoses and cables
- No need for mid-hoist disconnection of hoses and movement of pump.

SHS, SHAS Series



Capacity Per Lifting Point:

55 - 225 ton

Maximum Stroke:

500 - 1000 - 1500 mm

Accuracy Over Full Stroke:

± 1,0 mm

Maximum Operating Pressure:

700 bar

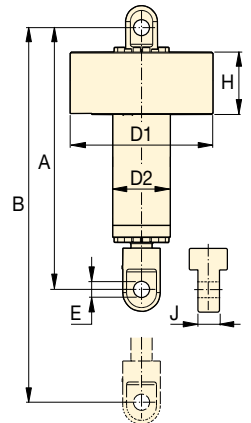

Capacity ton (kN)	Total Load ton (kN)	Cylinder Stroke (mm)	Model Number SHS = 400 VAC-3 ph, 50 Hz SHAS = 400-500 VAC, 3 ph, 50-60 Hz	Control System	Motor Size (kW)	Number of Pump Outlets and Oil Flow ³⁾ (l/min)	Cylinder Dimensions (mm)						Weight (kg) ⁴⁾	
							A	B	D1	D2	E	H		J
4 x 55 (4 x 539)	220 (2156)	500	SHS45520MW ¹⁾	Manual	7,5	4 x 1,4	1300	1800	690	245	59	385	80	450
		1000	SHS45540MW ¹⁾				1800	2800						625
		1500	SHS45560MW ¹⁾				2300	3800						800
		500	SHS45520AW ¹⁾	Automatic	15	4 x 2,1	1300	1800	450					
		1000	SHS45540AW ¹⁾				1800	2800	625					
		1500	SHS45560AW ¹⁾				2300	3800	800					
4 x 85 (4 x 833)	340 (3332)	500	SHS48520MW ¹⁾	Manual	11	4 x 2,1	1330	1830	690	265	72	385	100	500
		1000	SHS48540MW ¹⁾				1830	2830						700
		1500	SHS48560MW ¹⁾				2330	3830						900
		500	SHS48520AW ¹⁾	Automatic	15	4 x 2,1	1330	1830	500					
		1000	SHS48540AW ¹⁾				1830	2830	700					
		1500	SHS48560AW ¹⁾				2330	3830	900					
4 x 110 (4 x 1078)	440 (4312)	1000	SHS411040MW ¹⁾	Manual	11	4 x 2,1	1855	2855	780	315	85	395	124	970
		1500	SHS411060MW ¹⁾				2355	3855						1235
		1000	SHS411040AW ¹⁾	Automatic	15	4 x 2,1	1855	2855						970
		1500	SHS411060AW ¹⁾				2355	3855						1235
4 x 110 (4 x 1078)	440 (4312)	1000	SHAS411040WE ²⁾	Wireless	4 x 4,0	-	1855	2855	1063	315	85	540	124	1183
		1500	SHAS411060WE ²⁾				2355	3855						1448
4 x 225 (4 x 2204)	900 (8816)	1000	SHAS422540WE ²⁾	Wireless	4 x 8,0	-	2140	3140	1235	420	142	580	190	3219
		1500	SHAS422560WE ²⁾				2640	3640						3414

¹⁾ SHS: With 4 cylinders and one 400 VAC-3 phase-50 Hz Powerpack (suffix W). For 460-480 VAC-3 phase-60 Hz Powerpack change suffix W into J. Example: SHS45560MJ.

²⁾ SHAS: WE = 400-500 VAC, 3ph, 50-60 Hz with European electrical wiring. Change into suffix "WU" for US-market. Example: SHAS411060WU.

³⁾ SHS: Pump and cylinders include 4x 25 meters hydraulic hoses with couplers.

⁴⁾ Weight per cylinder.

▼ One leg of ML40 Mini-Lift Hydraulic Gantry



- Compact design for use in areas with limited space
- Self-contained hydraulics with synchronized lifting for enhanced safety
- Powered travel, under load, standard on all models for ultimate utilization
- Three-stage, double-acting cylinder provides extended lifting capacity
- Easy-to-use handheld pendant control can operate four legs simultaneously
- Compatible with standard Enerpac gantry accessories
- Operates on 115, 230 VAC 1-phase or 380-415 VAC 3-phase power (1 circuit per leg)
- ASME B30.1 compliant and load tested under witness of Lloyd's Register.

▼ SL400 gantry used to offload and install new forming press.



▼ SBL1100 gantry offloading a large generator for installation in a power plant.



Lift Heavy Machinery Safely

Portable design with precision control



Header Beams

Sold in pairs and includes lifting points and fork pockets for easy positioning on gantry towers.

Description	Model Number
6 metres length	HBH6
8 metres length	HBH8



Skid Tracks

Skid tracks used for leveling and load distribution to reduce ground bearing pressure. Available in two standard lengths.

Description	Model Number
3 metres length	GST100-3
6 metres length	GST100-6

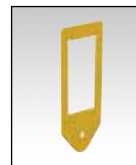

Lifting Anchors

Designed to transfer the load to the top of the header beam. Can accommodate a 250-ton shackle or attach directly to the lifted load.



Higher Capacities SL and SBL-Series Hydraulic Gantries

When the ML-Series Mini Gantry isn't quite enough capacity or height for your application,

Enerpac offers a full range of safe-to-operate full featured telescopic hydraulic gantries, up to 10.484 kN capacity and lifting heights up to 12 metres. Contact Enerpac for more details.

Mini-Lift Hydraulic Gantry



ML-Series, Mini-Lift Gantry

The cost-effective, compact ML40 Mini-Lift Hydraulic Gantry System, with wireless controls offers several key features:

Safety:

Stroke synchronization ensures a level lift regardless of load distribution. PLC-controlled lifting using feedback from a stroke encoder maintains even height on all legs and will stop the lift if necessary to prevent issues.

Capacity:

400 kN lifting capacity at full extended lift height. Even with its compact size, the ML40 can lift full capacity to full height of 5,5 metres (18 ft), making it the most versatile portable gantry in the market.

Compact:

Fits through standard doorway and is easily moved and set up. The ML40 gantry can be moved through the tightest spaces imaginable in all industrial settings. Easy to push, pull and maneuver, the ML40 can get into spaces that no other gantry can.

ML Series



Capacity (with 4 legs):

400 kN

Maximum Lifting Height:

5,5 metres



Wireless Pendant

- Stroke measurement and closed loop synchronization ensure level lifting and lowering
- Integrated 1.8 inch color display provides load and stroke information for all four lift points.



Mini-Lift Gantry Transport Frame

Galvanized steel transport frames to allow shipment of mini gantry legs via standard truck lines.

Two legs mount on each frame

which includes storage for controls and accessories.

Description	Model Number
Set of two frames	ML40TF



Operating Voltages

ML40 is available in three voltages. 1 circuit per leg.

Voltage	Model Number
115 V, 1 phase, 16 A	ML40B
208-240 V, 1 phase, 8 A	ML40E
380-415 V, 3 phase, 2 A	ML40W

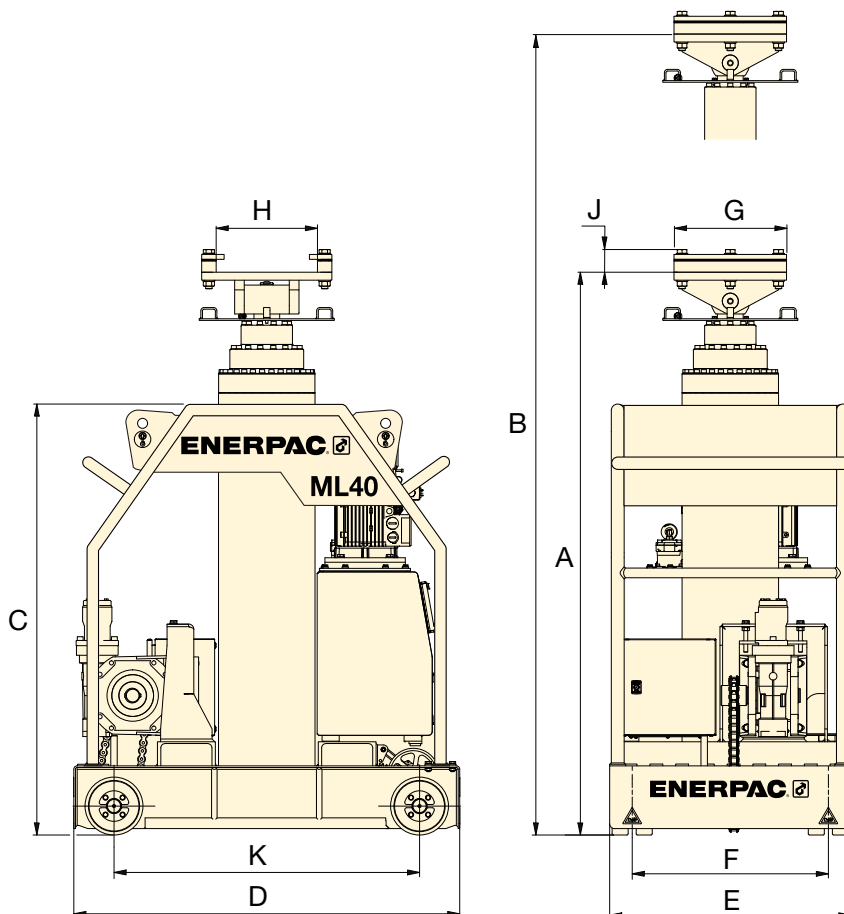

Max. Capacity *	Model Number (4 legs)	Retracted Height A (mm)	Stage 1		Stage 2		Stage 3		Base Height C (mm)	Base Length D (mm)	Base Width E (mm)	Track Gauge F (mm)	Beam Plate			Wheel Base K (mm)	Wheel ** (kg)
			Max. Height B (mm)	Max. Capacity *	Max. Height B (mm)	Max. Capacity *	Max. Height B (mm)	Max. Capacity *					Length G (mm)	Width H (mm)	Height J (mm)		
400	ML40	1900	3000	400	4200	400	5500	400	1390	1200	750	610	350	315	71	950	1350

* Capacity with 4 legs.

** Weight per leg including oil.

SL, SBL-Series, Telescopic Hydraulic Gantries **ENERPAC**

▼ SBL1100 with optional skid tracks, header beams, powered side shifts and lifting anchors



- Self-contained hydraulics and electronics
- Intelli-Lift wireless control system
- Self-propelled wheels or tank rollers
- Foldable boom on SBL600, SBL900 and SBL1100 to enable easy transport and setup
- Full range of supplementary equipment: header beams, lifting anchors, side shifts and skid tracks
- All gantries comply to ASME B30.1, CE, UKCA and other safety standards
- Lloyds witness tested to 125% of maximum working load.

Precision Lift and Position of Heavy Loads

The Ultimate in Safety and Control



Intelli-Lift Wireless Control

The Intelli-Lift wireless control system is included with all Enerpac hydraulic gantries.

The Intelli-Lift controller offers superior safety and control and includes the following features:

- Encrypted bi-directional communication that eliminates interference from other devices
- Remote operation using multi channel wireless (2.4 GHz) or wired (RS-485) control
- High and low speed settings
- Automatic synchronization of lifting with an accuracy of 24 mm (0.95 inch)
- Automatic synchronization of travelling with an accuracy of 15 mm (0.60 inch)
- Overload and stroke alarms
- Remote side shift control
- Emergency stop switch.



ML40, Mini-Lift Hydraulic Gantry

400 kN lifting capacity at full extended lift height. Even with its compact size, the ML40 can lift full capacity to full height of 5,5 metres (18 ft), making it the most versatile portable gantry in the market.

Page: **364**

▼ Enerpac SBL-Series hydraulic gantries are used in a variety of applications to install turbines, transformers and other power generation equipment all over the world.



Maximum Capacity (with 4 towers)	Model Number (4 towers)	Retracted Height
(kN)		A (mm)
1000	SL100	2050
2000	SL200	2731
3000	SL300	2715
4000	SL400N	2725
4000	SL400	3166
5200	SBL500	3028
6000	SBL600	4300
8976	SBL900	5004
10.484	SBL1100	4370

Telescopic Hydraulic Gantries



Hydraulic Gantries

Telescopic Hydraulic Gantries are a safe, efficient way to lift and position heavy loads in applications where traditional cranes will not fit and permanent overhead structures for job cranes are not an option.

Hydraulic Gantries are placed on skid tracks to provide a means for moving and placing heavy loads, many times with only one pick.

Enerpac Hydraulic Gantry Systems:

- **ML-Series Mini-Lift**

Fits through standard doorway and is easily moved and set up. The ML40 gantry can be moved through the tightest spaces imaginable in all industrial settings.

- **SL-Series Super Lift**

The cost-effective SL-Series Super Lift offer control and stability for everyday lifting applications below 4000 kN up to 9 metres.

- **SBL-Series Super Boom Lift**

The heavy-duty SBL-Series Super Boom Lift boom style gantries offer increased lifting capacity of over 4000 kN to heights of 12 metres.

All Enerpac gantries are delivered with specific properties and control systems to ensure optimum stability and safety.

SL, SBL Series



Capacity with 4 towers:

1000 - 10.484 kN

Lift Height:

3,5 - 12 meters

▼ Optional Gantry Accessories

Contact Enerpac for assistance by email at enerpac.com/contact-us



Skid Tracks

Allows for easy levelling of the gantry tower and reduce ground bearing pressure, available in two standard lengths, 3 and 6 m.



Header Beams

Sold in pairs and includes lifting points and fork pockets for easy positioning on gantry towers. Available in standard lengths of 8, 10 and 12 meters

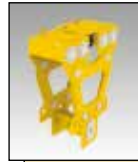

Powered Side Shift

Electric propulsion controlled by standard gantry controls. Each set consists of 4 units.



Lifting Anchors

Designed to transfer the load to the top of the header beam. Can accommodate a 250 ton shackle or attach directly to the lifted load.

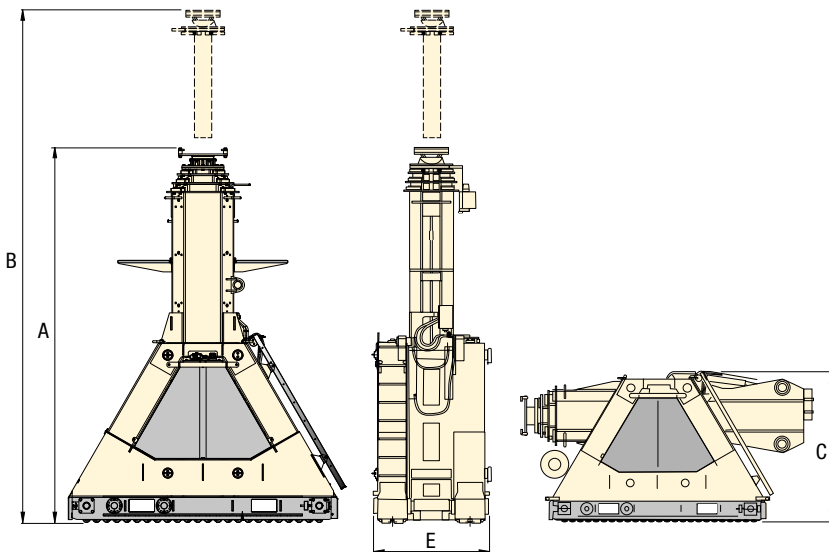

Stage 1		Stage 2		Stage 3		Transport Height ¹⁾	Skid Track Width	(kg) ²⁾	Model Number (4 towers)
Max. Height	Max. Capacity *	Max. Height	Max. Capacity *	Max. Height	Max. Capacity *				
B (mm)	(kN)	B (mm)	(kN)	B (mm)	(kN)	C (mm)	E (mm)		
3400	1000	4750	600	-	-	1930	812	1735	SL100
4716	2000	6700	1360	-	-	2611	812	2200	SL200
4615	3000	6710	2000	-	-	2900	812	3250	SL300
4365	4000	6025	3000	7700	2000	2725	812	3600	SL400N
5224	4000	7232	4000	9140	1840	3170	1218	4600	SL400
4998	5200	6908	5200	8618	3000	3028	1218	6300	SBL500
6500	6000	8600	5000	10.600	3700	2250	1218	9000	SBL600 ¹⁾
8304	8976	11.304	5924	-	-	2243	1218	13.350	SBL900 ¹⁾
7004	10.484	9668	6756	12.002	3780	2244	1218	11.950	SBL1100 ¹⁾

* Maximum capacity with 4 towers.

¹⁾ Foldable boom on SBL600, SBL900 and SBL1100.

²⁾ Weight per tower.



▼ LH-Series, Low-Height Skidding System



- **Low starting height saves time and increases versatility**
- **Portable design allows for easy transport and setup**
- **System can push or pull load without relocating skidding cylinder**
- **Skid track sections bolt together to allow each setup to be customized as needed**
- **Replaceable PTFE skid pads lower the total cost of ownership.**

▼ LH400, Low-Height Skidding System provides the service team with the ability to maneuver and transport a press frame.



Low-Height Skidding System for Heavy Loads

The Ideal Low-Height Jack & Slide Solution



Skidding Systems

The Skidding System is comprised of a series of skid beams moved by hydraulic push-pull cylinders, travelling over a pre-constructed skid track.

A series of special PTFE-coated Teflon® pads are placed on the skid tracks to reduce friction. The push-pull cylinders are then connected by hydraulic hoses to our Split-Flow Pump. The Split-Flow Pump can be mounted on an optional pump cart for easy transport.

An optional storage and transport frame easily holds the equipment in between use.

▼ LH400 Skidding used to remove an old press from a facility to make room for new equipment.



Low-Height Skidding System



Low-Height Skidding Jack Starter Kit - LH400SK

A complete starter kit is available to fit the needs of any jack and slide application. This system comes with two skidding units that will support up to 3560 kN in total. This kit will get the job done, but there are optional accessories available in addition (see page 370-371).

Each skidding unit will have 1 push-pull unit, 2 skid beams and 5 skid tracks.

The Split-Flow Pump (to be ordered separately) has 2 outlets and can be easily towed on the pump cart. After the job is complete, components can be stowed on the included storage frame.

LH400SK Starter Kit includes:	Model Numbers	Qty
Push-Pull Unit (1780 kN)	LHPP25	2x
Skid Beam A (1 meter)	LHSB1A	2x
Skid Beam B (1 meter)	LHSB1B	2x
Skid Track (1 meter)	LHST1	10x
Storage/Transport Frame	LHSF	1x

LH Series



Skidding Capacity with two push-pull units:

3560 kN

Push-Pull Stroke:

600 mm

Maximum Operating Pressure:

700 bar

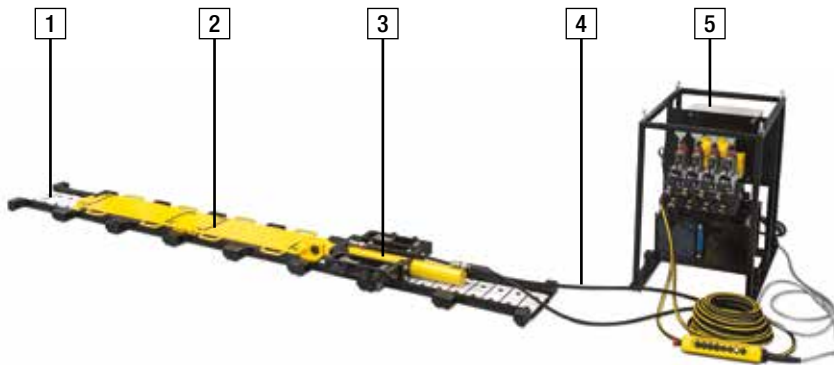

LH-Series, Low-Height Skidding System Requirements

1	Skid Track LHST1	Required
2	Skid Beam LHSB1A + LHSB1B	Required
3	Push-Pull Cylinder Unit LHPP25	Required
4	Hydraulic Hoses	Required
5	Split-Flow Electric Pump SFP	Required
6 *	Track Support	Application dependant
7 *	Storage-Transport Frame LHSF	Optional
8 *	Pump Cart LHPC	Optional

* not shown

LH400, Low-Height Skidding System (dimensions in mm)

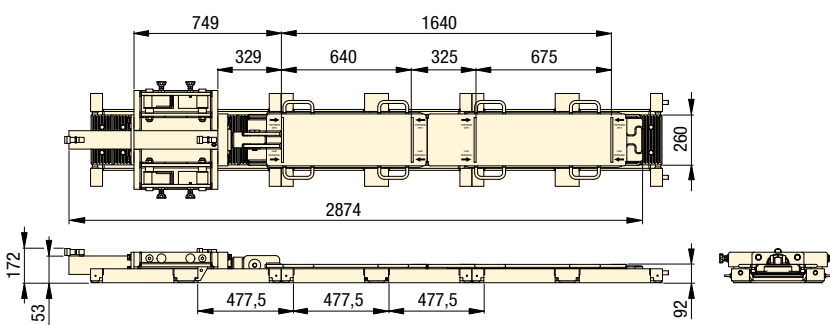

SFP-Series, Split-Flow Pump

Split-Flow pumps distribute an equal amount of hydraulic oil to a maximum of 8 outlets. Smart valve technology allows both controlled lifting and lowering of heavy loads.

Page: 344



LHPC Pump Cart

The LHPC pump cart easily tows pump around jobsite and can be used with all models of SFP-Series Split-Flow Pumps.



Hydraulic Power Packs

Enerpac offers a comprehensive range of hydraulic power packs that are optimized for use with Skidding Systems.



Hoses

Enerpac offers a complete line of high quality hydraulic hoses. To ensure the integrity of your system, specify only genuine Enerpac hydraulic hoses.

Page: 128

▼ LHPP25 Low-Height Push-Pull Unit

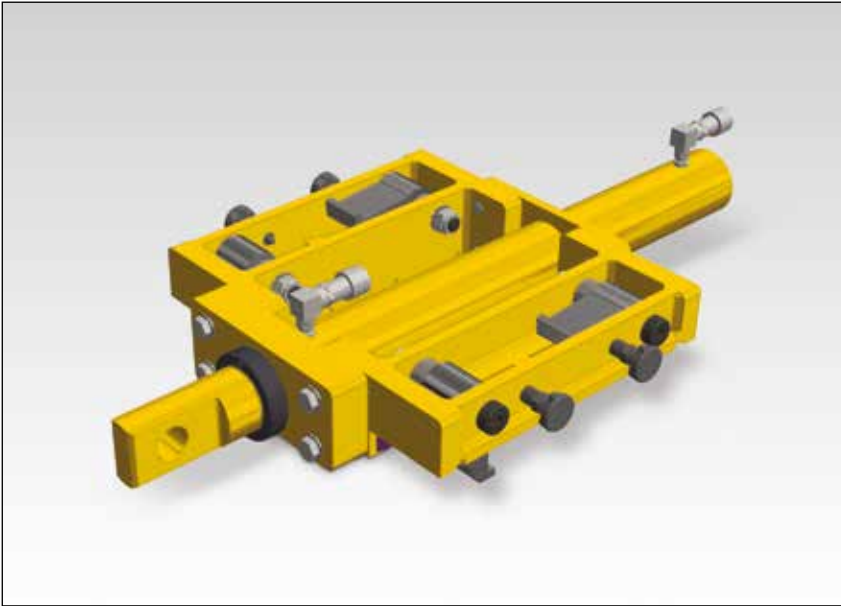

Push-Pull Unit

- Connects to first skid beam to push or pull load along skid track
- Easily reverse direction by switching reaction tabs
- Complies to ASME B30.1 and other safety standards.

▼ Low-Height Push-Pull Unit

Maximum Capacity (kN)		Model Number	Stroke (mm)	Weight (kg)
Push	Pull			
222	97,8	LHPP25	600	111

▼ LHSB1A and LHSB1B Skid Beams



Skid Beams

- Interlocks without any fasteners to slide load over skid track;
skid beam A (LHSB1A) attaches to the push-pull unit
skid beam B (LHSB1B) attaches to skid beam A
- Polished stainless steel skid surface
- Carrying handles for easy transport.

▼ Skid Beams

Capacity (kN)	Model Number	Weight (kg)
890	LHSB1A	66
890	LHSB1B	63



◀ Details of push-pull unit of LH400.

Low-Height Skidding Components

▼ LHST1 Skid Track

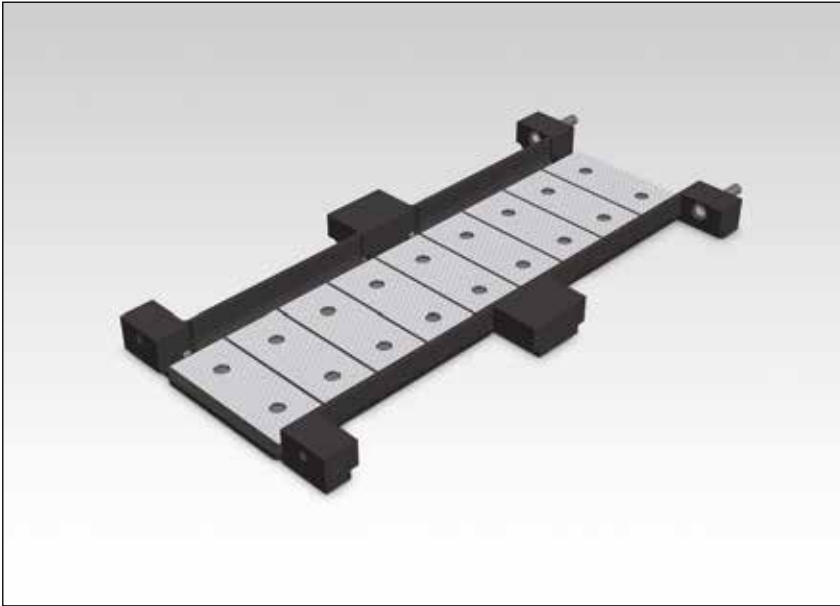

Skid Track

- Support the load for skidding operations
- Track sections bolt together
- Includes 9 pieces easily replaceable PTFE skid pads.

▼ Skid Track

Maximum Capacity (per skid track) (kN)	Model Number	Track Length (mm)	Weight (incl. pads) (kg)
890	LHST1	955	67

▼ An LH400 Skidding System allows the maintenance team to transport transformers with access limitations.



▼ Low-Height Skidding System assembly (LH400).



LH Series



Skidding Capacity with two push-pull units:

3560 kN

Push-Pull Stroke:

600 mm

Maximum Operating Pressure:

700 bar



Teflon® Pads

A series of special PTFE coated Teflon® pads are placed on the skid tracks. The PTFE surface is matched with the skid beam and designed to achieve minimum friction coefficients.

Replacement Teflon® Pads come in packs of 12 pieces. Order model number **HSKSPS1**.



Storage and Transport Frame

For easy storage and transport of all low-height skidding components.

Fits following components:

2x **LLPP25** Push-Pull Unit

2x **LHSB1A** Skid Beam A

2x **LHSB1B** Skid Beam B

10x **LHST1** Skid Tracks

Model Number	Overall Dimensions L x W x H (mm)	Weight (kg)
LHSF	1080 x 935 x 895	200

With all components stored dimensions are: 1080 x 935 x 1003 mm, and total weight 1350 kg.

▼ Shown: HSK1250 Skidding System



HSK-Series, Skidding System

- PTFE skid pads with dimpled surface for low friction and long lifetime
- Easy to replace skid pads, no tools necessary
- Bi-directional operation using push-pull cylinders avoid the need to reposition cylinders for switching direction
- Large load support surface on the skid beams for distributing load
- Bottom of skid shoes equipped with stainless steel sliding plates.

LH-Series, Low-Height Skidding System

- 2-in-1 track design for added support
- Intuitive pump controls (SFP-Series Split-Flow Pump)
- Easily reversible to change skidding direction
- Portable design for quick setup.

▼ A custom hydraulic Low-Height Skidding System will provide the maintenance team with the ability to maneuver and transport transformers with physical access limitations.



The Ideal Jack and Slide Solution



Skidding Systems

The skidding system is comprised of a series of skid beams moved by hydraulic push-pull cylinders, travelling over a pre-constructed track.

A series of special PTFE coated pads are placed on the skid tracks. The PTFE surface is matched with a sliding plate under the Enerpac skid beams, designed to achieve minimum friction coefficients. The skid beams are connected by hoses to a hydraulic electric or diesel driven power pack.

In addition to our standard skidding systems, we have the capability to create customized skidding systems to meet your specific requirements.



Controls

Enerpac offers several options for controlling our skidding systems. Wireless Controls allows the operator the freedom to view the skidding operation from multiple locations while providing complete control of all system functions.

Manual controls offer a cost-effective solution by utilizing manual hydraulic valves mounted directly on the skidding system power unit.

▼ HSKJ2500 Skid Shoe Jack.





Skidding Systems

Enerpac Skidding Systems are available in several versions:

- **B-Series (Skid Beam)** utilizes a tall skid beam with built-in push-pull cylinders. Skidding direction can be easily switched by flipping a lever on the attached gripper box.
- **J-Series (Skid Jack)** provides the same functionality as the B-Series with the added benefit of having a built-in cylinder for lifting or leveling the load.

- **LH-Series (Low-Height)** includes low-height skid beams that can fit in tight spaces while still offering high capacity. We also offer a track support for added rigidity when the surface is not fully supported.

HSK LH Series



Capacity:

125 - 250 ton

Push/Pull Stroke:

600 mm

Lifting Stroke:

175 mm

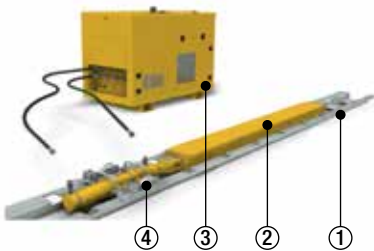

HSK-Series Skidding System Requirements

- ① Skid Track
- ② Skid Beam
- ③ Hydraulic Power Pack
- ④ Hydraulic Push-Pull Unit

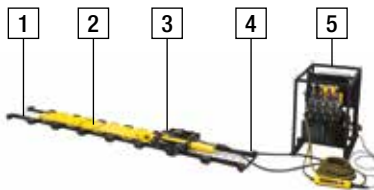

LH-Series Skidding System Requirements

- 1 Skid Track (required)
- 2 Skid Beam (required)
- 3 Push-Pull Cylinder Unit (required)
- 4 Hydraulic Hoses (required)
- 5 Split-Flow Electric Pump (required)
- 6 Track Support (optional, not shown)
- 7 Storage/Transport Frame (optional, not shown)
- 8 Pump Cart (optional, not shown)

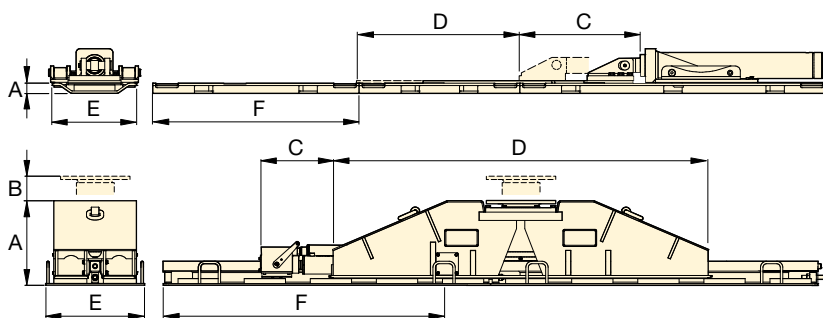

Skidding Systems

Maximum Capacity (per beam)	Maximum Push-Pull Capacity ton (kN)		Model Number	Skid Beam Height (with track)	Lifting Stroke	Push-Pull Stroke	Skid Beam Length	Skid Beam Weight	Skid Track Width	Skid Track Length	Skid Track Weight
	ton (kN)	Push									
125 (1250)	22 (220)	16 (160)	HSKB1250	309	–	600	2500	740	400	1983	120
125 (1250)	22 (220)	16 (160)	HSKJ1250	502	175	600	1690	790	400	1983	120
200 (2000)	25 (255)	14 (141)	HSKLN2000	204	–	600	2902	340	540	1998	120
250 (2500)	40 (400)	26 (260)	HSKB2500	374	–	600	3000	1020	600	1946	290
250 (2500)	40 (400)	26 (260)	HSKJ2500	600	175	600	1784	1450	600	1946	290
180 (1780)	25 (255)	11 (98)	LH400 *	92	–	600	1080	63	250	955	67

* Low-Height Skidding System, see pages 368 - 371 for detailed and technical information.



Skid Tracks

Include specially constructed and easily replaceable PTFE coated pads. Skid track is sold separately.



Hydraulic Power Packs

Enerpac offers a comprehensive range of hydraulic power packs that are optimized for use with Skidding Systems.

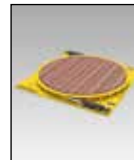

ETT-Series Turntables, Safe and controlled rotation

The ETT-Series Turntables is your solution for rotating heavy loads during, before or after a lifting and skidding operation.

▼ ETR50H, Enerpac Trolley System (shown with Trolley Track Plates)



- **High transport speed:**
25 - 50 m/hour loaded,
100 m/hour unloaded
- **Suited for repetitive movements**
- **Runs on simple flat steel plate**
- **Ease of maintenance:**
– long maintenance intervals
– no consumables
- **Clean usage – electric driven**
- **Built-in synchronization – no need for forced external mechanical connection to synchronize movements**
- **Easy transport - compact design**
- **Hydraulic lifting cylinder option available**
- **Kits to accommodate other lifting options also available.**

▼ The trolley system speeds up offshore wind transition piece load out: the transition pieces are positioned in the clamping frames and moved along the track.



▼ ETR-Series electric trolley undergoing factory acceptance testing prior to shipment.



Safe & Synchronized Travel



Product Overview

The ETR-Series Trolley System is comprised of electrically-driven trolleys which can carry heavy loads along a fixed track system.

The entire system is controlled by a hand held wireless control system.

A typical system is comprised of 4 Trolleys, 2 Tracks and one Controller. Trolley Tracks and Wireless Control must be ordered separately.



Control Panel and Cables

Operate up to 8 trolleys (same capacity each) using control panel with included wireless controller:

- Automatic synchronization of traveling with an accuracy of 10 mm (0.39 inch)
- Dual-band radio with automatic frequency search
- Wireless remote operation
- High and low speed settings
- Emergency stop switch
- Control cables operate trolley and provide feedback to controller.

Control Panel

Model Number (380-415 VAC, 32A)	Dimensions (mm)			Weight (kg)
	L	W	H	
ETR-CPW8	1290	600	1100	250

Control Cables

Model Number	Description
ETR-CBL-15	15 metres control cable
ETR-CBL-25	25 metres control cable



ETR-Trolley System

The Enerpac Trolley System provides an alternative method with increased benefits over traditional skidding methods.

Load movements are more stable due to the continuous movement and ability to precisely control travel speed including acceleration and deceleration.

Key features:

Low speed (loaded):	25 m/hr
High speed (loaded):	50 m/hr
Travel speed unloaded:	100 m/hr
Accuracy:	10 mm
Sideload:	1,5% rated load
Sound Level:	< 80 dBA

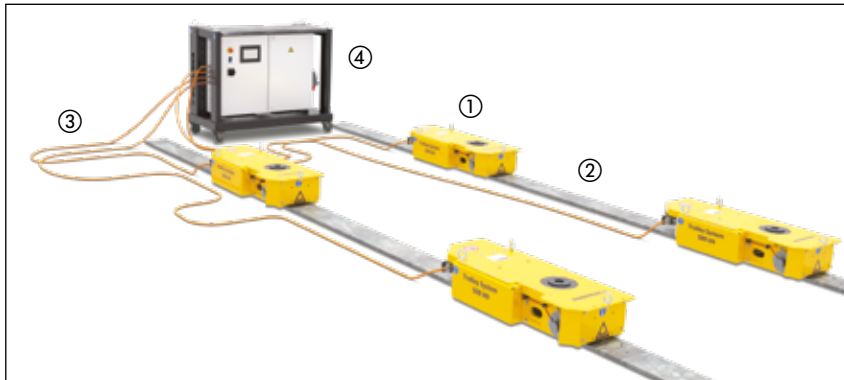

- ① Electric Trolley ETR-Series
- ② Track Plate **ETR-TP-015** or **ETR-TP-030**
- ③ Control Cable **ETR-CBL-15** or **ETR-CBL-25**
- ④ Control Panel **ETR-CPW8** (including wireless remote)
- ⑤ Split-Flow Electric Pump - **SFP-Series** Not shown. Optional for units with hydraulic cylinders

ETR50

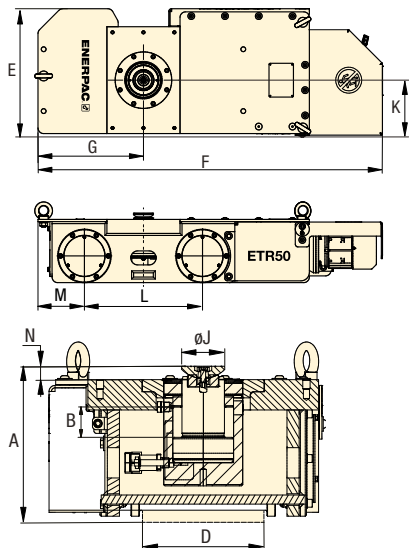

ETR100

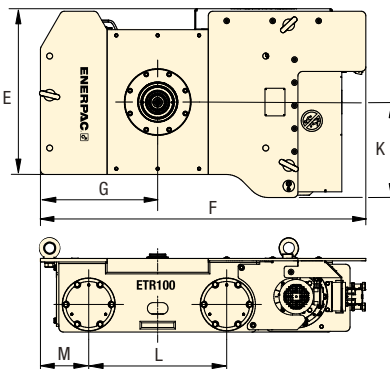

ETR Series



Capacity Per Trolley:

500 - 1000 kN

Travel Speed (loaded):

25 - 50 m/hr

Motor Power:

0,38 - 0,75 kW



Trolley Track Plates

Track plates provide level guidance and support for the trolley. Two plates placed side-by-side are used for operation of

ETR100-Series Trolleys. Maximum inclination of tracks is 0,2 degree.

Model Number	Description
ETR-TP-015	1,5 m Trolley track plate
ETR-TP-030	3,0 m Trolley track plate



Additional Mounting Options

Mounting kits are available to accommodate other lifting and rigging solutions.

Model Number	Description
ETR50-SMK	Enerpac SCJ50 on ETR50
ETR100-SMK	Enerpac SCJ100 on ETR100
ETR50-BMK	Swivel beam mount on ETR50
ETR100-BMK	Swivel beam mount on ETR100

Capacity per Trolley Unit ton (kN)	Model Number (one unit)	Motor Power (kW)	Dimensions (mm)											(kg)
			A	Hydraulic Stroke ¹⁾	Track Width ²⁾	E	F	G	J	K	L	M	N	
50 (500)	ETR50	0,38	245	–	200	456	1225	375	125	202	420	165	10	310
	ETR50H		257	50					71				22	
100 (1000)	ETR100	0,75	346	–	400	821	1415	510	170	415	600	210	15	850
	ETR100H		349	100					71				19	

¹⁾ ETR50H includes HCG502 Cylinder with CATS50 Swivel Saddle. ETR100H includes HCG1004 Cylinder with CATS101 Swivel Saddle.

²⁾ ETR100 series uses two track plates side-by-side.

▼ ETT400 Turntable

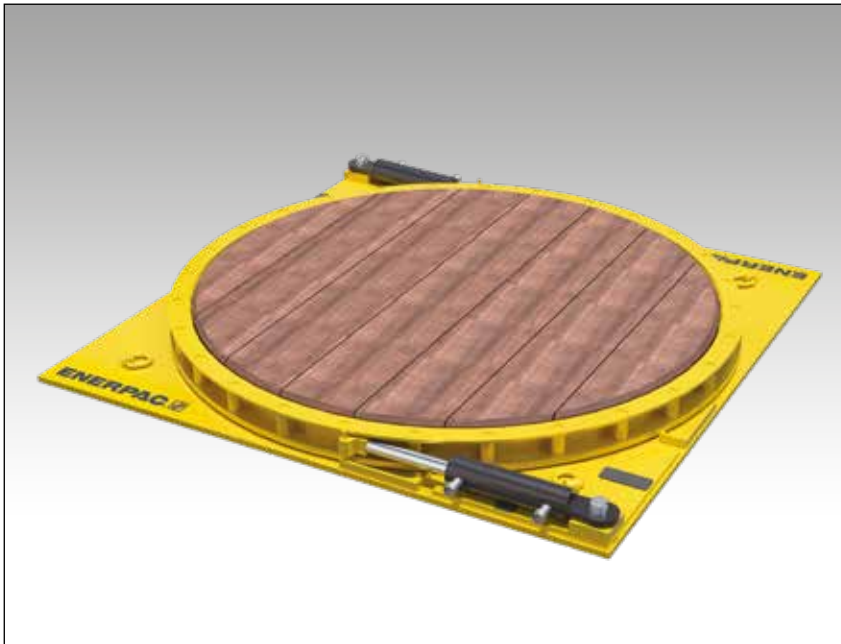

- Safe and controlled rotation of heavy loads
- Easily change rotation direction
- Dual capacity: 200 ton with one cylinder, 400 ton with two cylinders
- Compact size for use in applications with limited space
- Compatible with standard Enerpac pumps
- Hardwood surface.

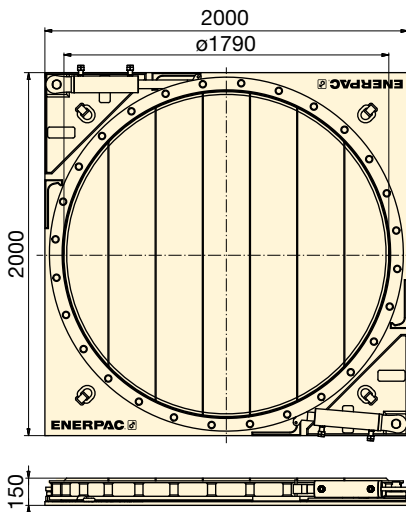

▼ SELECTION CHART

Maximum Load Capacity (kN)	Model Number	Cylinder Capacity * (kN)	Cylinder Oil Capacity * (cm ³)		No. of Cylinders *	Rotation per Stroke (degrees)	Platform Diameter (mm)	(kg)
			advance	retract				
2000	ETT200	222	792	344	1	12,5	1790	1700
4000	ETT400	222	792	344	2	12,5	1790	1725

* Per cylinder. Cylinder modelnumber: **BRD259-ETT**

ETT Series

Maximum Capacity:
200 - 400 ton

Cylinder Capacity:
25 ton (222 kN)

Maximum Operating Pressure:
700 bar



Safe and controlled rotation

The ETT-Series is your solution for rotating heavy loads during, before or after a lifting and skidding operation.



SFP-Series, Split-Flow Pumps

Split-Flow pumps distribute an equal amount of hydraulic oil to a maximum of 8 outlets. Smart valve technology allows both controlled lifting and lowering of heavy loads.

Page: **344**



LH-Series, Low-Height Skidding

The ETT-Series are ideal in combination with our skidding systems, particular the LH-Series. Skidding and rotating in confined spaces is simplified.

Page: **368**



Telescopic Hydraulic Gantries

The ETT-Series in combination with our hydraulic gantry SL-Series makes load handling in the most demanding situations easy.

Page: **366**

SPMT, Self-Propelled Modular Transporter

▼ SPMT600-360 with MTPP360 hydraulic power unit (HPU)



- Modular design for multiple configurations.
- Minimized height and slim design are ideal for in-plant operation
- Intelli-Drive wireless control system is intuitive and easy to use
- One power pack can operate 2-3 trailers maximum depending on model
- Two trailers and power pack can be shipped inside a 20 ft. container
- Hydraulic power unit is tier-4 diesel engine for reduced emissions.

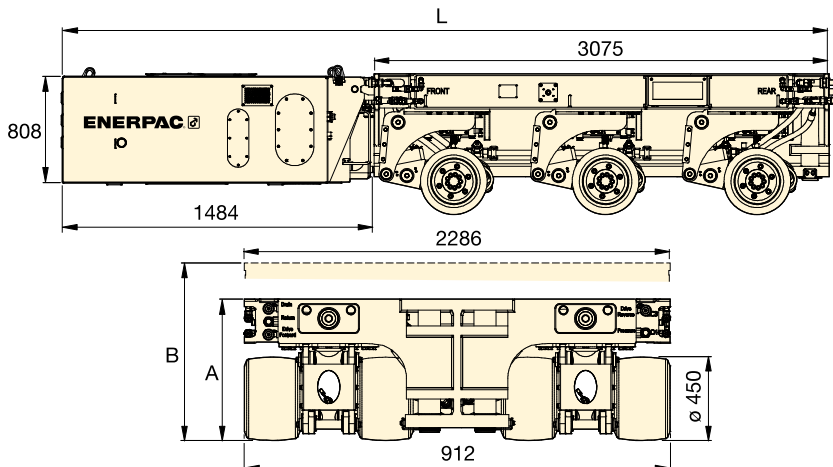

SPMT Series

Capacity:

60 ton (600 kN)

Transport Speed (unloaded - loaded):

3 - 1,5 km/h

Motor Size:

54 kW



Self-Propelled Modular Transporter

The Enerpac Self-Propelled Modular Transporter (SPMT) features a minimized height and slim design, which makes it very easy to operate in confined spaces. Each wheel unit has a steering function as well as a lifting cylinder at its disposal. Two axles are driven, the centre axle is non-driven. Wheel propulsion is established by wheel drives.

The SPMT is operated by the Intelli-Drive Remote Controller. This remote controller can be used both hard wired and wireless (based on radio frequency).

The SPMT is a modular system and can be built up to a maximum configuration of six transporters in a row and two in the width. This is the maximum setup of units that can work together on just one Intelli-Drive Remote Controller.



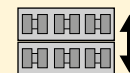

The SPMT is a modular system comprised of trailers with 3 axle lines each and diesel hydraulic power units (HPU). Depending on the model number, the trailers and HPUs can be configured to a maximum of 4 trailers in 2 rows (4x2) or 6 trailers in 2 rows (6x2).



Crab



Carousel

Capacity (per transporter) ton (kN)	Transporter Model Number	Maximum Configuration (transporters in rows)	Steering Range (degrees)	Steering Mode		Retracted Height A (mm)	Average Travel Height B (mm)	Overall Length L (mm)	Lifting Stroke (mm)	 SPMT (kg)	HPU * Model Number	 HPU * (kg)
				 crab	 carousel							
60 (600)	SPMT600-100	4 x 2	+/- 50	●	—	767	959	4560	384	8000	MTPP-100	2500
	SPMT600-360	6 x 2	+/- 179	●	●	764	956	5188	384	8300	MTPP-360	2800

* HPU = 54 kW Power Pack Diesel is sold separately.



OFFSHORE GANTRY CRANE

The Enerpac Over Head Travel Crane (OHTC) comprises two pairs of lifting beams, with an overall width of 30m, and a lifting capacity of 4800 ton for lifting, moving and lowering the concrete blocks for the offshore highway.



STRAND JACK GANTRY

The strand jack gantry is a steel structure to facilitate erection and skidding back, forth and sideways of heavy loads. The Enerpac strand jack gantry can be used with either skidding systems or hydraulic gantries on top.



TRAVEL GANTRY

The travel gantry combines the safety and efficiency of a hydraulic gantry with the ease of use of SPMT (self-propelled modular transporter) technology. With a lifting capacity of 67 ton, the travel gantry sets a new standard in equipment and container handling.



BRIDGE LAUNCHING SYSTEMS

Spindle Bar System: group of in-line hollow plunger cylinders. The hollow plungers allow the steel bars to be inserted through the cylinders, which are used for pushing, pulling and braking. **Enerpac Enerlauncher** is an automatic and synchronous incremental hydraulic tandem launching system with a 800 ton lifting section and an 300 ton push/pull section.



JACK-UP SYSTEMS

The jack-up system is a custom developed multipoint lifting system – synchronically lift and mechanically hold. A typical system setup includes four jack-up units positioned under each corner of a load.



ROTOR REMOVAL AND INSTALLATION SYSTEM

The generator rotor removal and installation system is a custom developed product for removing and installing the rotor (field) in a power plant's generator. The system is designed to comply with the varying dimensions and challenging accessibility of a plant's generator.



CUSTOM HYDRAULIC PRESSES

Our hydraulic presses can be configured to fulfill a broad range of applications. Each press is designed and manufactured according to customer specifications and in cooperation with our engineering team.



SELF-ERECTING TOWER

The Enerpac Self Erecting Tower (ESET) is a self-erecting tower lift system that enables you to build a free standing gantry from ground level. The ESET can be supplied in various capacities and lifting heights and is built with standard modular components, enabling a flexible solution to future project demands.



LAS VEGAS WHEEL

Our expertise has been acknowledged by the world's leading industrial professionals and has contributed to the successful movement of a number of the most recognizable structures on earth. At the time of construction the Las Vegas High Roller was the largest observation wheel in the world. A custom hydraulic drive system was developed to propel the wheel for daily use and was also used to construct the wheel in sections.

FROM SIMPLE TO COMPLEX – LIFTING SOLUTIONS FOR YOUR APPLICATION

For those who do the heavy lifting today, the stakes are high and the challenges complex. We know our customers put their reputations and physical well-being on the line to get the job done right. We take that very seriously.

Backed by a global legacy of ultra-reliable quality and superior precision, Enerpac Heavy Lifting Technology is pushing the industry forward with a wide range of advanced solutions that first and foremost ensure our customers operate safely and productively every day. It isn't about being compliant, or "as good" as the next guy; we outpace the competition by delivering technically superior solutions that are easy to design, safe to use and built to outlast.

CONSULTATIVE APPROACH TO HEAVY LIFTING

From the very first discussion to gain an understanding of your application to solution design, training and ongoing field support of your operators, you will find a structured process and a team of application experts who will advise you towards a successful solution.



SOLUTION CONSULTATION

- Requirements Specifications
- Selecting the Right Solution for Your Application

DESIGN & MANUFACTURING

- Design & Engineering
- Manufacturing Excellence

TESTING & TRAINING

- Quality Assurance
- Operation & Safety Training

ON-DEMAND SUPPORT

- On-the-job Application Engineer Support
- Routine Maintenance & Repair Services

SOLUTION CONSULTATION

- Requirements Specifications
- Selecting the Right Solution for Your Application

Since the late 1950's, Enerpac has been steadfast in their commitment to work closely with customers to understand their lift needs and work-site environment. Not all lifts are the same. There are several factors that must be taken into consideration before recommending the best solution.

APPLICATION CONSIDERATIONS

LOAD CAPACITY

How much weight needs to be lifted, moved and/or positioned?

LIFT HEIGHT

How high does the load need to be lifted? Are there restrictions above or below the load?

TYPE OF LIFT

Will you lift from above or below?

SPACE

How much space is available to complete the task?

TIME

How the job needs to be completed within a set timeframe due to operational or environmental factors.

TRANSPORTATION

Does the load need to be transported as well as being lifted? How far and how often?

TOTAL COST OF OWNERSHIP

What productivity, labor or training costs need to be factored into the solution to make it the best long-term investment.

Because Enerpac engineers have designed solutions for a variety of applications over the years, they are well-equipped to minimize risks and to recommend a simpler solution that others may overlook. Built on a world-class reputation for developing products that meet the most common lifting applications,

once your specifications are in the hands of the Enerpac experts, you are sure to receive a comprehensive recommendation that will save time and money while ensuring safety above all else.



Enerpac has the most complete offering of standard heavy lifting and positioning tools in the market. These products are designed to highest standards of performance and offer great flexibility to meet the demands of even the most challenging applications. Our manufacturing facility adheres to world-class production planning and inventory management to ensure your product arrives at your facility on time as specified.

DESIGN & MANUFACTURING

- Design & Engineering
- Manufacturing Excellence



Design & Engineering

Enerpac engineers are experienced in the latest software, rapid prototyping, failure analysis methods and engineering standards. This allows us to continuously improve and expand our product offering to meet ever changing needs of the market.

- CE, Machinery Directive 2006/42/E
- ASME: B30.1



Assembly & Quality Assurance

All Enerpac products are assembled by highly trained individuals, working safely and efficiently from start to finish. The Hengelo, NL facility that manufactures the Enerpac heavy-lifting equipment holds several quality certifications.

- ISO 9001: 2015
- ISO 3834-2: 2005
- ISO 14001: 2015
- ISO 45001: 2018



Fabrication & Machining

A dedicated steel fabrication and certified welding facility manufactures product components and support structures for the most demanding heavy-lifting applications. Complete in-house production is delivered using the latest CNC and conventional turning machines plus a full range of milling and boring equipment.



TESTING & TRAINING

- Quality Assurance
- Operation & Safety Training

The Enerpac facility, that makes and builds your heavy-lifting equipment, holds several quality system certifications giving you extra confidence in the safety and reliability of your heavy-lifting equipment. Whether your first lift or move is scheduled upon taking delivery of your new equipment or months later, you will have access to the dedicated Heavy-Lifting team to support your training or troubleshooting needs.



Factory Acceptance Testing (FAT)

Customers are invited to witness FAT, often combined with operator training. Under witness of Lloyd's Register, all equipment is functionally tested to maximum capacity, and in many cases up to 125% of rated load. Additional testing to meet standards compliance, government regulations or specific customer requirements are performed and documented at the same time.



Documentation

Upon delivery of your new heavy-lifting equipment, an operator's manual outlines the configuration of your system, detailed operating instructions with safety guidelines, and maintenance recommendations.



Training

Customers who attend factory acceptance training at Enerpac's facility can also receive a day of training on their heavy lifting equipment. Additional training or on-site custom training can also be arranged.



Once you take possession of your new heavy-lifting equipment, you have on-demand access to our field support team. And support continues with ongoing maintenance or system upgrades throughout the life of your assets.

ON-DEMAND SUPPORT

- On-the-job Application Engineer Support
- Routine Maintenance & Repair Services



On-the-Job Field Support

Should you ever require extra support while using your Enerpac Heavy-Lifting system on the job, our dedicated application engineers will work closely to guide your operators on appropriate use of our equipment. And to ensure job safety, they will travel to your job site as needed to ensure your project is completed timely and without incident.



Product Warranty

All Enerpac Heavy-Lifting equipment is built to stringent specifications and built to last. Should you ever encounter a defect in materials or workmanship under normal use, it will be remedied through our standard one-year warranty program.



Maintenance & Repair

Downtime is minimized with fast delivery of repair parts and consumables stocked at several locations worldwide. For those that want the added confidence of specialized technicians, the Enerpac Maintenance & Repair team are ready to perform your maintenance or repair services for you.



Since joining the Enerpac portfolio, the design innovation of Mirage machines has continued to deliver new products that help get the job done faster, safer, and smarter. Explore the full Mirage product line from flange facing machines, milling machines, hot tapping, drilling and tapping machines to clamshell pipe cutters, decommissioning and band saws. All backed by Enerpac training, application support and service.

Design & Innovation

On-site Machine Tools are the result of over 25 years of expertise and innovation. The pioneering spirit continues under Enerpac ownership through our commitment to new product development. Watch out for more new tools being launched in the near future!

Continuous Improvement

Our specialist manufacturing operation is ISO9001 certified. This means we drive a culture of continuous improvement. Our team members are encouraged to find ways to improve today, tomorrow, and long into the future.

Specialist Support, Experience & Expertise

Each machining project presents difficult and unique challenges. Making the right choice for your next and any future projects can be complex. That is why our team is eager to support you through every step on your journey. Whether it is choosing the right specification, commissioning your machine, or maintenance - we're with you all the way.



Specialist Support, Experience & Expertise



Utilities



Nuclear



Oil & Gas



Petrochemicals



Power Generation



Ship Building, Maintenance and Repair













Wind Power

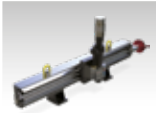

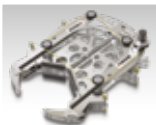
Construction and Mining

On-site Machining Tools – Overview

Machining Capacities	On-site Machining Tools	Series		Page
<p>ø 1 - 161 inches ø 25,4 - 4100 mm</p>	<p>Internal Mount Flange Facing Machines Create the right flange sealing surface</p>	<p>FF MM-I</p>		<p>386 ▶</p>
<p>ø 0 - 80 inches ø 0 - 2032 mm</p>	<p>External Mount Flange Facing Machines Create the right flange sealing surface</p>	<p>MM-E</p>		<p>387 ▶</p>
<p>ø 2 - 86 inches ø 51 - 2184 mm</p>	<p>Clamshell Pipe Cutting and Beveling Machines Narrow Body, Mid-Size and Heavy-Duty</p>	<p>DLR</p>		<p>388 ▶</p>
<p>ø 98 - 315 inches ø 2500 - 8000 mm</p>	<p>General Orbital Milling Machines Machine large flanges accurately and efficiently</p>	<p>OM</p>		<p>390 ▶</p>
<p>ø 70 - 181 inches ø 1800 - 4600 mm</p>	<p>Wind Power Orbital Milling Machines Machine large flanges accurately and efficiently</p>	<p>WP</p>		<p>391 ▶</p>
<p>40 - 120 inches 1000 - 3000 mm</p>	<p>Linear Milling Machines On-site milling with workshop precision 2 and 3-Axis Configuration</p>	<p>LMR MR, MRY GMRF</p>		<p>392 ▶</p>
<p>ø 1/2 - 60 inches ø 12,7 - 1524 mm</p>	<p>Hot Tapping Machines & Line Stopping Actuators Built to deliver power where it matters most</p>	<p>HTM, LPH MHT, CHT LSA</p>		<p>394 ▶</p>
<p>ø 6 - 60 inches ø 152 - 1524 mm</p>	<p>Decommissioning Diamond Wire & Band Saws Cutting the toughest materials</p>	<p>MDWS BS</p>		<p>396 ▶</p>
<p>ø 2 - 12 inches ø 51 - 305 mm</p>	<p>Drilling & Tapping Machines Make light work of the toughest applications</p>	<p>HT T DDU</p>		<p>398 ▶</p>
<p>ø 7/8 - 11 inches ø 22 - 279 mm</p>	<p>GeniSYS™ IV 3-axis CNC Mill Removal of cracked or broken studs and refurbishment of damaged threads</p>	<p>GeniSYS™</p>		<p>400 ▶</p>
<p>ø 3/4 - 40 inches ø 19 - 1016 mm</p>	<p>Inline Isolation & Test Tools Piping Isolation and Pressure Testing</p>	<p>MITT</p>		<p>402 ▶</p>

Internal Mount Flange Facing Machines



FF120

- Mechanical tool manually operated
- Simple to operate
- Lightweight - only 15 lbs (6,8kg)
- Multiple leadscrew options allow for manually driven continuous fixed feeds for ASME standard surface finishes
- Calibrated slide to define cut depth and correct finish.



MM305I and MM610I

- Swivel toolpost for groove details, reduces the need for separate accessories
- Supplied with a range of 2 quick set base sizes for improved onto site operation
- Collet base allows for efficient machine mounting and centering.



MM860I and MM1000I

- 360 swivel toolpost for groove details, reduces the need for separate accessories (power feed on MM1000I)
- Supplied with a range of 3 quick set base sizes for improved onto site operation
- Adjustable height clamping jaws for efficient machine setting.



MM1500I

- Power feed 360 swivel toolpost for groove details, reduces the need for separate accessories
- Supplied with a range of 3 quick set base sizes for improved onto site operation
- Adjustable height clamping jaws for efficient machine setting.



MM2000I

- Power feed 360 swivel toolpost for groove details, reduces the need for separate accessories
- Supplied with a range of 2 quick set base sizes for improved onto site operation
- Adjustable height clamping jaws for efficient machine setting.



MM3000I and MM4500I

- Power feed 360 swivel toolpost for groove details, reduces the need for separate accessories
- Supplied with a range of 3 quick set base sizes for improved onto site operation
- Adjustable height clamping jaws for efficient machine setting
- Milling accessories available with the Hydraulic drive version.



Flange Facing Machines

Flange Facers are known for precision construction, the results they deliver, and how easy they are to set-up on-site. These high-performing machines produce continuous groove facing feeds to ASME standards for the oil & gas, power generation and petrochemical industries.

MM-I Series feature

- Hardened slideways for long term accuracy
- High torque low noise drive
- Heat exchanger machining accessories available on most models.

Applications

- Heat exchanger flanges
- Hub profiles
- Lens ring joints & Raised face flanges
- Recessed gaskets and spigots
- Ring type joint grooves (RTJ)
- SPO compact flanges
- Swivel ring & TECHLOK flanges
- Welding preparations.

▼ MM860I machine to ensure flange joint integrity.



Internal Mount Flange Facing Machines

Flange Facing Diameter Range		Machine Model Number	Drive Power Options	
(inch)	(mm)		Pneum.	Hydr.
1 – 12	25 – 305	FF120 *		
2 – 12	51 – 305	MM305I	•	
2 – 24	51 – 610	MM610I	•	
6 – 34	152 – 864	MM860I	•	
6 – 40	152 – 1016	MM1000I	•	•
12 – 60	305 – 1524	MM1500I	•	•
24 – 80	610 – 2032	MM2000I	•	•
5 – 120	127 – 3048	MM3000I	•	•
83 – 161	2100 – 4100	MM4500I		•

* FF120 is not suitable for lens-ring joint flanges or ring type joint (RTJ) flanges.

Flange Facing Machines

External Mount Flange Facing Machines



MM200E

- Preloaded cross roller bearing drive, ensuring robust, accurate, repeatable machining
- Hardened slideways for long term accuracy
- Swivel toolpost for groove details, reduces the need for separate accessories
- Continuous fixed feed for ASME standard surface finish
- Quick set integrated clamping jaws.



MM300E

- Preloaded cross roller bearing drive, ensuring robust, accurate, repeatable machining
- Hardened slideways for long term accuracy
- Swivel toolpost for groove details, reduces the need for separate accessories
- Multiple continuous fixed feeds for ASME standard surface finishes
- Quick set intergrated clamping jaws.



MM600E

- Preloaded cross roller bearing drive, ensuring robust, accurate, repeatable machining
- Hardened slideways for long term accuracy
- Power feed 360 swivel toolpost for groove details, reduces the need for separate accessories
- Multiple continuous fixed feeds for ASME standard surface finishes
- Quick set intergrated clamping jaws.



MM760E, MM1000E, MM1250E, MM1500E, MM1775E, MM2000E

- Continuous variable auto-feed for ASME standard finishes
- Choice of pneumatic and hydraulic drive motors
- Quick-set radial clamping adjustment
- Quick-set axial adjustment jaws
- Heavy duty bearing construction for high metal removal rates and accuracy
- Heat exchanger kits for back facing and slot machining in one operation.

External Mount Flange Facing Machines

Flange Facing Diameter Range		Machine Model Number	Drive Power Options	
(inch)	(mm)		Pneum.	Hydr.
0 - 8	0 - 203	MM200E	•	
0 - 12	0 - 305	MM300E	•	
0 - 24	0 - 610	MM600E	•	
0 - 30	0 - 762	MM760E	•	•
0 - 40	0 - 1016	MM1000E	•	•
0 - 50	0 - 1270	MM1250E	•	•
0 - 60	0 - 1524	MM1500E	•	•
0 - 70	0 - 1778	MM1775E	•	•
0 - 80	0 - 2032	MM2000E	•	•

FF MM Series



Internal Mount Facing Diameter:

1 - 161" / 25,4 - 4100 mm

External Mount Facing Diameter:

0 - 80" / 0 - 2032 mm

Cutting Resultant Roughness:

Ra 125-492 μin / 3,2-12,5 μ



Surface finish & accuracy

All flange facing machines provide a serrated finish with 30-55 grooves per inch and a resultant roughness of between Ra 3,2-12,5μ (125-492 micro inches). Geared multiple continuous groove facing feeds for a gramophone finish (ASME Standard).

▼ MM600E external mount flange facing machine to ensure flange joint integrity.



Narrow Body & Mid-Size Clamshell Cutters



DLR-NB12, NARROW BODY CLAMSHELL CUTTER

- NB or "Narrow Body" portable clamshells are ideal when space is at a premium
- Standard NB-series cover a range from 2 to 36" outside diameter (51 to 914 mm)
- Narrow body design: ideal when space is at a premium or obstructions present
- Pneumatic, hydraulic, and electric drive options
- Several different drive options are available to best position the motor for a specific machining application
- Accepts a wide range of accessories to increase performance and expand capabilities
- Full range of bevel and sever tools available.

DLR-MS30, MID-SIZE CLAMSHELL CUTTER

- Mid-size machines weigh less than the HD heavy-duty series, but provide greater rigidity than the NB-narrow body series
- Standard MS-series cover a range from 4 1/8 to 48 1/4" outside diameter (105 to 1226 mm)
- Increased manoeuvrability and greater clearance than the HD series
- Several different drive options are available to best position the motor for a specific machining application
- Accepts a wide range of accessories to increase performance and expand capabilities
- Full range of bevel and sever tools available.



◀ NB-model narrow body clamshell cutter.

NB Narrow Body Series Clamshell Cutters

Mounting Outside Diameter (min. - max.)		Machine Model Number	Drive Power Options		
(inch)	(mm)		Pneumatic	Hydraulic	Electric
2 - 4 1/2	51 - 114	DLR-NB4	•	•	
2 3/8 - 6 5/8	60 - 168	DLR-NB6	•	•	
3 1/2 - 8 5/8	89 - 219	DLR-NB8	•	•	•
4 1/2 - 10 3/4	114 - 273	DLR-NB10	•	•	•
6 5/8 - 12 3/4	168 - 324	DLR-NB12	•	•	•
8 5/8 - 14	219 - 356	DLR-NB14	•	•	•
10 5/8 - 16	219 - 406	DLR-NB16	•	•	•
12 3/4 - 18	324 - 457	DLR-NB18	•	•	•
14 - 20	356 - 508	DLR-NB20	•	•	•
18 - 24	457 - 609	DLR-NB24	•	•	•
20 - 26	508 - 660	DLR-NB26	•	•	•
22 - 28	559 - 711	DLR-NB28	•	•	•
24 - 30	610 - 762	DLR-NB30	•	•	•
26 - 32	661 - 813	DLR-NB32	•	•	•
30 - 36	762 - 914	DLR-NB36	•	•	•

MS Mid-Size Series Clamshell Cutters

Mounting Outside Diameter (min. - max.)		Machine Model Number	Drive Power Options	
(inch)	(mm)		Pneumatic	Hydraulic
4 1/8 - 13	105 - 330	DLR-MS12	•	•
7 3/8 - 16 1/4	187 - 413	DLR-MS16	•	•
9 3/8 - 18 1/4	238 - 464	DLR-MS18	•	•
11 3/8 - 20 1/4	289 - 514	DLR-MS20	•	•
15 3/8 - 24 1/4	391 - 616	DLR-MS24	•	•
19 3/8 - 28 1/4	492 - 718	DLR-MS28	•	•
21 3/8 - 30 1/4	543 - 769	DLR-MS30	•	•
23 3/8 - 32 1/4	594 - 819	DLR-MS32	•	•
27 3/8 - 36 1/4	695 - 921	DLR-MS36	•	•
27 3/8 - 36 3/4	708 - 934	DLR-MS365	•	•
33 3/8 - 42 1/4	848 - 1073	DLR-MS42	•	•
39 3/8 - 48 1/4	1000 - 1226	DLR-MS48	•	•



Clamshell Cutters

Clamshell cutters in the Enerpac range remain true to the pioneering designs that made DL Ricci the 'go-to' brand for machinists worldwide. Outstanding performance and a comprehensive choice has seen them used widely for applications in new construction, decommissioning, component replacement, fabrication, and maintenance.

Robust and efficient pipe cutting and bevelling

Designed for any industry that needs pipe or tube cutting, or any pipe end preparation weld repair. This may be in oil and gas sector, power generation, ship building/dock yards, or processing plants during maintenance and shut downs.

Applications

- Pipe cutting
- Weld preparation
- Cutting materials, including super duplex, carbon steel, stainless steel, hastelloy and incolloy
- For pipe diameters up to 86 inch (2184 mm)
- Ideal for projects beyond the usual clamshell configuration – using a wide range of purpose designed accessories.

Included as Standard with Each Machine

- Clamshell body
- Locators & extensions covering the full range
- Slides
- Motor & Mounting
- Air Caddy
- Tool Kit
- Manual
- Shipping crate.

Clamshell Pipe Cutting & Beveling Machines

HD Heavy-Duty Clamshell Cutters



DLR-HD54, HEAVY-DUTY CLAMSHELL CUTTER

- Robust body design - ideal for large diameter heavy wall pipe applications
- 16 HD-models cover a range of 20 - 86" outside diameter (508 - 2184 mm)
- Pneumatic and hydraulic drive options
- Fully adjustable heavy duty bearing design provides greater serviceability
- Stepped and keyed gear clamps equipped with a through bolt provide a positive fit at each assembly joint
- Accepts a wide range of accessories to increase performance and expand capabilities
- Full range of bevel and sever tools available.

HD Heavy-Duty Series Clamshell Cutters

Mounting Outside Diameter (min. - max.)		Machine Model Number	Drive Power Options	
(inch)	(mm)		Pneumatic	Hydraulic
20 - 32	508 - 813	DLR-HD32	•	•
24 - 36	610 - 914	DLR-HD36	•	•
27 - 39	686 - 990	DLR-HD39	•	•
31 - 43	787 - 1092	DLR-HD43	•	•
33 - 45	838 - 1143	DLR-HD45	•	•
36 - 48	915 - 1219	DLR-HD49	•	•
38 - 50	966 - 1270	DLR-HD50	•	•
41 - 53	1042 - 1346	DLR-HD53	•	•
42 - 54	1067 - 1360	DLR-HD54	•	•
43 - 55	1092 - 1397	DLR-HD55	•	•
45 - 57	1143 - 1448	DLR-HD57	•	•
48 - 60	1220 - 1524	DLR-HD60	•	•
54 - 66	1372 - 1676	DLR-HD66	•	•
60 - 72	1524 - 1828	DLR-HD72	•	•
68 - 80	1728 - 2032	DLR-HD80	•	•
74 - 86	1880 - 2184	DLR-HD86	•	•

DLR Series



Outside Mounting Diameter Range:

2 - 86 inches

Outside Mounting Diameter Range:

51 - 2184 mm



Recommended Accessories for Clamshell Cutters

Other clamshell accessories available. Details available on request.

Counter-bore Swivel Head Modules

- 10 inch size available
- Match boring applications
- Up to 60 degree adjustability in the head
- Internal diameter bevelling.

Description	Part Number
2 inch travel	F0108A1224AA-SK
6 inch travel	F0108A1224AB-SK

Low Profile Tool Slide

- Brings cut line closer to the back of machine
- Allows cutting & bevelling on short pipe sections
- Use for facing, RTJ grooves and compound angle weld preparations.

Description	Part Number
Low profile slide	F0130A0016XX

Out-of-round Tool Block Slide

- Dual compensating Spring Assembly
- Rides on OD of pipe and tracks the contour
- For up to 1 inch out-of-round.

Description	Part Number
Out of round slide	F0130A0022XX
Trippler for NB models	F0145A0019XX
Trippler for MS models	F0145A0020XX
Trippler for HD models	F0145A0028XX

▼ OM6000 Orbital Milling Machine



Machine large flanges accurately and efficiently

- Precision flatness tolerances across large diameters
- Hydraulic high-torque anti-backlash drive
- Precision preloaded linear rotary drive
- Adjustable fast-set hydraulic chuck
- Rigid and adjustable mounting base.

OM Series

Cutting Diameter Range:

98 - 315 inches

Cutting Diameter Range:

2500 - 8000 mm



General Orbital Milling Machines

Orbital milling machines are designed to deliver fast material removal and achieve high accuracy across large flange diameters.

Applications

- Machining crane bearing faces
- Repairing drag lines
- Machining large flanges
- Machining ship thruster flanges.

▼ Milling a ship thruster flange.



▼ Machining crane bearing face.

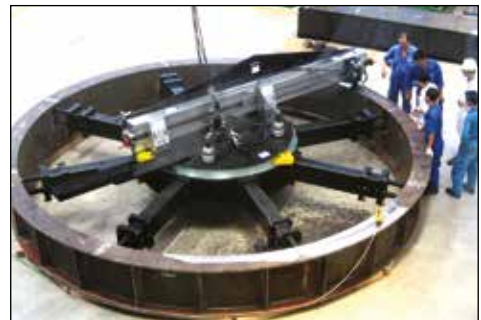

General Orbital Milling Machines

Cutting Diameter Range (min. - max.)		Machine Model Number	Hydraulic Power Drive
(inch)	(mm)		
98 - 178	2500 - 4500	OM4500	•
98 - 237	2500 - 6000	OM6000	•
138 - 315	3500 - 8000	OM8000	•

Wind Power Orbital Milling Machines

▼ WP3500 Wind Power Orbital Milling Machine

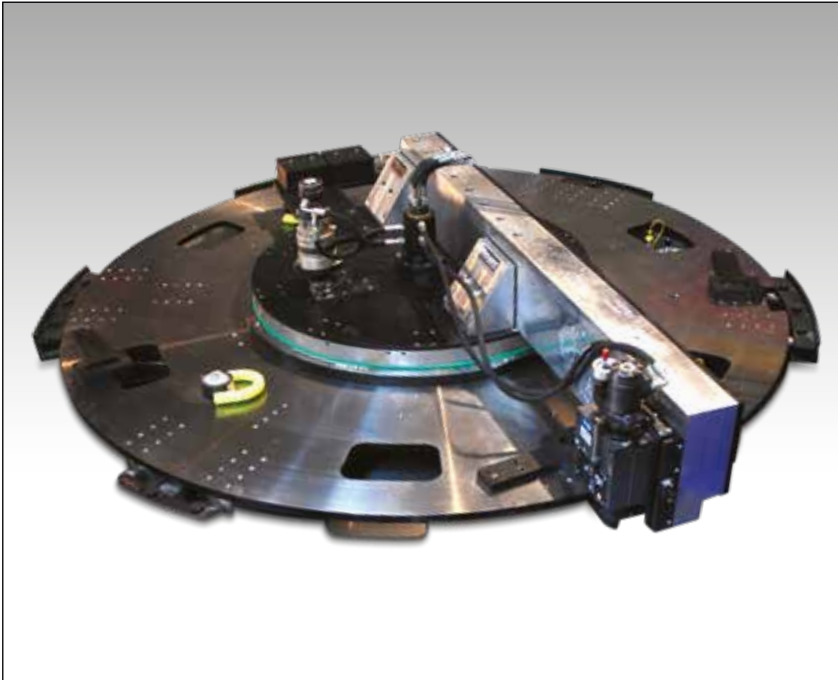

WP Series

Cutting Diameter Range:
70 - 181 inches

Cutting Diameter Range:
1800 - 4600 mm



Wind Power Orbital Milling Machines

The wind power orbital milling range is designed especially for companies manufacturing wind turbine rotor blades and towers.

Applications

- Wind turbine blade root end milling
- Wind tower flange machining.

Machine large flanges accurately and efficiently

- Fully packaged system; includes trolley, power unit and base
- Accurate and repeatable process time
- Minimum distortion fast mount hydraulic base
- Adjustable arm for different diameters
- Patented hydraulic mounting system for blade and tower production
- Direct drive spindle
- High torque anti-backlash drive.

▼ Wind tower machining with WP4600.



▼ WP3500 milling turbine blade end.



Wind Power Orbital Milling Machines

Cutting Diameter Range (min. - max.)		Machine Model Number	Hydraulic Power Drive
(inch)	(mm)		
70 - 96	1800 - 2450	WP2500	•
90 - 137	2300 - 3500	WP3500	•
110 - 181	2800 - 4600	WP4600	•

2-Axis Milling Machines

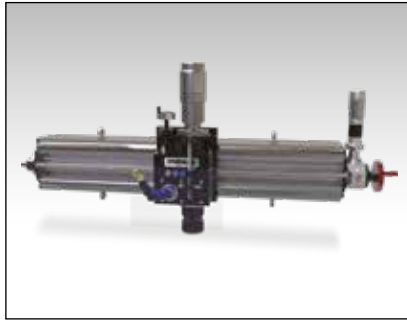
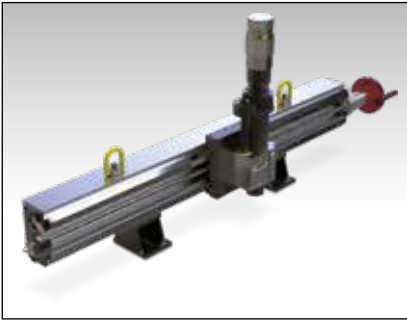

LMR1000, 2-AXIS MILLING MACHINE

- Ideal for lightweight applications
- Hand feed to main axis; auto feed optional
- Features ER40 Collet with ISO30 spindle option
- Choice of Pneumatic and Hydraulic drive.

MR1000, 2-AXIS MILLING MACHINE

- Induction hardened 'V' rails ensure accuracy and durability
- Ball-screw feed
- Hand & auto feed to main axis
- Direct drive ISO 40 spindle
- Choice of Pneumatic and Hydraulic drive
- Variety of mounting options including; bolting, switch magnets, pipe chain clamps and gantry.

LMR, MR, MRY Series

X-Axis Maximum Stroke:

40 - 120" / 1,0 - 3,0 m

Y-Axis Maximum Stroke (MRY-Series only):

12 inches / 305 mm

3-Axis Milling Machines

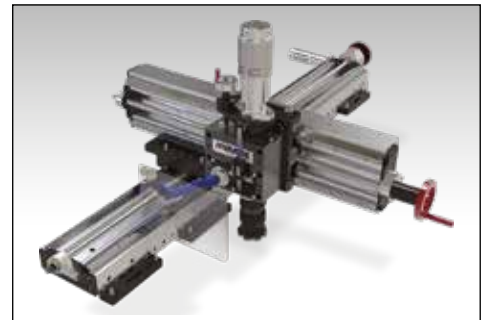

MRY1500, 3-AXIS MILLING MACHINE

- Induction hardened 'V' rails ensure accuracy and durability
- Ball-screw feed
- Hand & auto feed to main axis
- Direct drive ISO 40 spindle
- Choice of Pneumatic and Hydraulic drive
- Variety of mounting options including; bolting, switch magnets, chain clamps and gantry.

▼ MRY Milling machine on a heat exchanger.



2-Axis Linear Milling Machines

X-Axis Maximum Stroke		Machine Model Number	Drive Power Options	
(inch)	(mm)		Pneumatic	Hydraulic
40	1000	LMR1000	•	•
60	1500	LMR1500	•	•
80	2000	LMR2000	•	•
40	1000	MR1000	•	•
60	1500	MR1500	•	•
80	2000	MR2000	•	•
120	3000	MR3000	•	•

3-Axis Linear Milling Machines

X-Axis Maximum Stroke		Y-Axis Maximum Stroke		Machine Model Number	Drive Power Options	
(inch)	(mm)	(inch)	(mm)		Pneumatic	Hydraulic
60	1500	12	305	MRY1500	•	•
80	2000	12	305	MRY2000	•	•
120	3000	12	305	MRY3000	•	•

Gantry Milling Machine

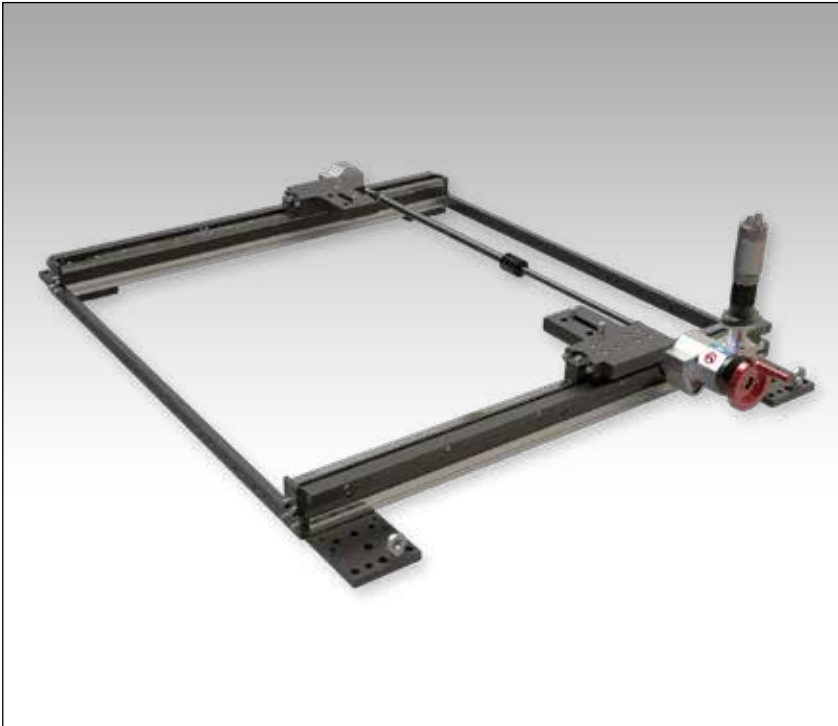

GMRF1000, GANTRY RAIL KIT

- Modular jointing system for lengths up to 10 m
- Linear rail and precision carriages
- Quick set up with jacking system
- Auto and manual feed
- Optional quick-set magnets for mounting.

GMRF Series

X-Axis Maximum Stroke:

40 - 394" / 1,0 - 10,0 m

Y-Axis Maximum Stroke:

40 - 118" / 1,0 - 3,0 m



Linear Milling Machines – Take workshop precision to your next on-site milling project

These precise and robust milling machines are available in 2 and 3 axis configurations. Each includes the latest workshop tool technology in a portable format. For a fast and efficient set-up, you can choose our optional switch magnets.

Applications

- Motor and pump mounting pads
- Aerospace machining
- Crane pedestals
- Heat exchanger repair
- Shaft keyways
- Steel mill housings
- Turbine split line machining.



I-Beam end face milling with a GMRF1000. ▶

Gantry Milling Machine

Feed Type	X-Axis Max. Stroke Options ¹⁾		Y-Axis Max. Stroke Options ²⁾		Machine Model Number	Drive Power Options	
	(inch)	(m)	(inch)	(m)		Pneumatic	Hydraulic
Rack Feed	40 - 394	1,0 - 10,0	40 - 118	1,0 - 3,0	GMRF1000	•	•

¹⁾ Common base module 1000 mm.

²⁾ MR milling rail required. Extension kits available.

▼ **HTM100**



HTM, MANUAL HOT TAPPING

- Operates to 1480 psi (102 bar)
- Versatile hot taps, bypass lines and completion plugs
- Manual rotation & feed
- Optional pneumatic feed
- 2" NPT connection
- Lightweight construction.

▼ **LPHT312**



▼ **MHT312**



LPHT312, LOW PRESSURE HOT TAPPING

- Operates up to 285 psi (20 bar)
- Pneumatic or hydraulic drive
- Depth stop to ensure correct hot tap distance.

MHT, HOT TAPPING MACHINES

- Pressure rating up to 1480 psi (102 bar)
- Helical geared drive situated close to the cutter
- Hydraulic and pneumatic drive options
- Industry standard connection flanges
- Compatible with industry standard tooling
- Fast traverse feed motors available
- Cutter holders included
- Interchangeable seal cartridge.

HTM, LPHT MHT Series



Tapping Diameters:

1/2 - 60" / 12,7 - 1524 mm

Maximum Stroke:

18 - 150" / 457 - 3810 mm

Maximum Operating Pressure:

285-1480 psi / 20-102 bar



Hot Tapping – Built to deliver power where it matters most

Hot tapping is a high-pressure intervention and our range of hot tapping machines can help towards a safe and effective solution. Industry-leading innovations used include a helical gear drive located as close to the cutting head as possible for maximum efficiency, rotary pressure seals, and four fixed feeds.

Applications

- Construction tie-ins
- Gas distribution
- Petrochemical pipelines
- Subsea pipelines
- Temporary installation
- Transmission pipelines
- Valve installation and repair
- Water mains pipelines
- Wellhead maintenance.

▼ *On-site hot tapping with MHT312.*



Hot Tapping Machines

Tapping Diameters (Min. - Max.)		Maximum Stroke		Max. Operating Pressure		Machine Model Number	Drive Power Options	
(inch)	(mm)	(inch)	(mm)	(psi)	(bar)		Pneumatic	Hydraulic
1/2 - 4	12,7 - 102	18	457	1480	102	HTM100	*	*
1/2 - 6	12,7 - 152	32	813	1480	102	HTM150XL	*	*
3 - 12	76,2 - 305	30	762	285	20	LPHT312	•	•
3 - 12	76,2 - 305	42	1067	1480	102	MHT312	•	
4 - 20	102 - 508	72	1829	1480	102	MHT420		•
8 - 24	203 - 609	80	2032	1480	102	MHT824		•
12 - 36	76,2 - 914	110	2794	1480	102	MHT1236		•
12 - 42	76,2 - 1066	132	3353	1480	102	MHT1242		•
24 - 60	203 - 1524	150	3810	1480	102	MHT2460		•

* HTM has manual rotation & feed.

Hot Tapping Machines & Line Stop Actuators

▼ CHT3000



CHT LSA Series

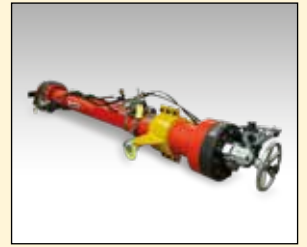

Tapping Diameters:

3 - 48" / 76 - 1219 mm

Maximum Stroke:

43 - 150" / 1092 - 3810 mm

Maximum Operating Pressure:

1480-5000 psi / 102-350 bar

▼ LSA1420-H



LSA-Series Line Stop Actuators

Line Stop Actuators (LSA) are used in conjunction with the required line stop head and housings to carry out line stops in surface or subsea environments.

The range is designed for easy use on pipelines in various materials and differing wall thickness. Their use provides temporary pipeline isolation, temporary or permanent bypass and no costly interruption of service.

CHT, HOT TAPPING MACHINES

- Working pressure capacity up to 5000 psi (350 bar)
- Drive as close to the cut enhances cut efficiency
- Auto feed - infinitely variable for differing cut conditions
- Constant pressure seal monitoring ports
- Internally pressure balanced for higher pressure applications
- Industry standard connection flanges
- Compatible with standard industry tooling.

LSA, LINE STOP ACTUATORS

- Series of four hydraulic line stop actuators covering a plugging head size range of 4 to 48 inches (102 - 1219 mm)
- Maximum working pressure of 1480 psi (102 bar) at 181 °F (83 °C)
- Failsafe mechanical lock prevents control rod movement
- Anti-rotation feature to ensure aligned plugging head deployment
- Hydraulic control situated at the working end of the cylinder for ease of use
- Visible control bar depth control.

CHT-Hot Tapping Machines & LSA-Line Stop Actuators

Tapping Diameters (Min. - Max.)		Maximum Stroke		Max. Operating Pressure		Machine Model Number	Drive Power
(inch)	(mm)	(inch)	(mm)	(psi)	(bar)		
3 - 12	76 - 305	43	1092	5000	350	CHT1000	•
3 - 16	76 - 406	66	1676	5000	350	CHT1675	•
6 - 24	152 - 609	80	2032	5000	350	CHT2000	•
12 - 48	305 - 1219	150	3810	5000	350	CHT3000	•
4 - 12	102 - 305	72	1829	1480	102	LSA412-H	•
14 - 20	356 - 508	102	2591	1480	102	LSA1420-H	•
22 - 36	559 - 914	140	3556	1480	102	LSA2236-H	•
38 - 48	965 - 1219	140	3556	1480	102	LSA3848-H	•



▲ CHT3000 hot tapping application for petrochemical pipeline installation.

▼ CHT2000 hot tapping offshore application.



▼ MDWS1638-H



Cutting the toughest materials in the most challenging environments

- Strong aluminum frame
- Overload clutch for bow damage prevention
- Hydraulic Auto Clamp and auto-feed
- Diver and ROV compatible
- Available with optional flotation modules for deep water use
- User replaceable clamp contact pads, wheels, and wheel liners
- Crimped or continuous loop wires available.

▼ Subsea pile cutting.

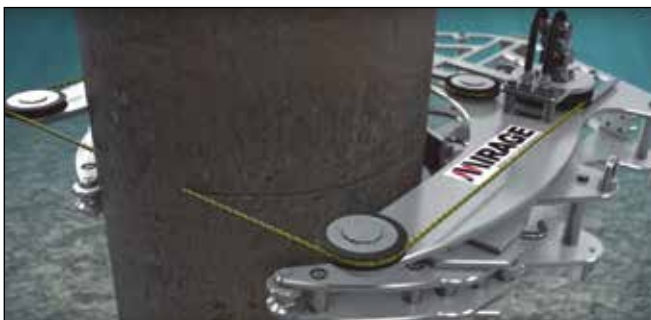

MDWS Series

Cutting Diameters:

6 - 60" / 152 - 1524 mm



Decommissioning Saws

A range of portable saws for a diverse range of tubular severance projects.

The band saw range delivers a cost-effective solution to cold cutting requirements in either surface or subsea situations. Diamond wire saws are ideal for cutting through dissimilar materials quickly.

Applications

- Offshore platform decommissioning
- Conductors, caissons, piles
- Multiple grouted strings
- Subsea ROV-applications
- Subsea structures
- Pipes, casings and risers.

Items included with each machine;

- Diamond wire rope
- Toolkit
- Storage / shipping crate
- CE Certificate
- Packing list and manual.



▲ MDWS Diamond Wire Saw lowered into sea.

Decommissioning Diamond Wire Saws

Cutting Diameters (Min. - Max.)		Machine Model Number	Main Application	Hydraulic Drive Power
(inch)	(mm)			
6 - 20	152 - 508	MDWS620-H	Subsea	•
16 - 38	406 - 965	MDWS1638-H	Subsea	•
36 - 60	914 - 1524	MDWS3660-H	Subsea	•

▼ BS1636-H



Cutting the toughest materials in the most challenging environments

- Fast, efficient and cost effective cold cutting
- Cuts grouted multiple casings
- Fast mounting system
- Vertical or parallel operation
- Fast clamping and set up
- Low height design for minimum clearances
- Extensive blade selection for all materials.

BS Series

Cutting Diameters:

9 - 36" / 228 - 914 mm



On-site Band Saws

Hydraulically powered portable band saws designed for tubular severance. Designed primarily for topside use, but also suitable for subsea applications.

Applications

- Offshore platform decommissioning
- Conductors, caissons, piles
- Multiple grouted strings
- Subsea ROV-applications
- Subsea structures
- Pipes, casings and risers.

Items included with each machine:

- Band Saw blade (2-3TP carbide tipped)
- Toolkit
- Storage / shipping crate
- CE Certificate
- Packing list and manual.



▲ Pipe cutting with BS portable band saw.

▼ Decommissioning job with band saw.



On-site Band Saws

Cutting Diameters (Min. - Max.)		Machine Model Number	Main Application	Hydraulic Drive Power
(inch)	(mm)			
9 - 24	228 - 610	BS924-H	Topside	•
16 - 36	406 - 914	BS1636-H	Topside	•

Drilling Machines



HT20

- 4MT spindle accepts standard tooling
- Linear rails & guides provide accuracy and high load carrying capacity
- Direct spindle drive
- Manual and variable auto feed.



HT50

- ISO50 geared spindle
- Linear rails & guides provide accuracy and high load carrying capacity
- Geared reduction spindle drive
- Manual and variable auto feed.



HT40

- ISO40 geared spindle
- Linear rails & guides provide accuracy and high load carrying capacity
- Geared reduction spindle drive
- Manual and variable feed.

▼ HT40 portable drilling machine.



HT Series

Drilling Capability:

Up to 5" / 127 mm

Maximum Stroke:

11 - 17" / 279 - 432 mm



Drilling & Tapping

Make light work of the toughest drilling and tapping applications

Drilling and tapping projects on-site require powerful and stable machines that deliver precise results first time.

Our machines are designed to do exactly this - giving you reassurance that the job will be done efficiently and to the right specification. They offer high torque and easy operation through their heavy-duty spindles with ISO standard tapers.

Optional switch magnet mounts and chain clamps are also available for a quick and easy setup.

For large scale offshore decommissioning projects, casing pin drills provide an effective solution for creating lift holes into casings - especially in the most challenging of working environments.

Applications

- Drilling through armour plate
- Bulkhead hole cutting
- Flange stud drilling
- Flange stud re-threading
- Motor pump stud removal
- Short stroke line boring
- Turbine case stud removal
- Turbine pin drilling
- Casing pin drilling.

Drilling Machines

Maximum Diameter with Standard Drills		Maximum Standard Stroke		Machine Model Number	Drive Power Options	
(inch)	(mm)	(inch)	(mm)		Pneumatic	Hydraulic
2	50,8	11	279	HT20	•	•
4	101,6	16	406	HT40	•	•
5	127,0	17	432	HT50	•	•

On-site Drilling & Tapping Machines

Tapping Machines



T30

- Rigid 3 pillar construction
- Quick key hole mounting
- Capable of tapping blind and through holes
- High torque reduction drive
- Hydraulic drive
- Pressure relief self feed system.



T725

- Heavy duty 4 pillar construction
- Quick key hole mounting system
- Capable of tapping blind and through holes
- High torque reduction drive
- Hydraulic drive
- Pressure relief self feed system.

T, DDU Series

Tapping Capability:

Up to 7¼" / 184 mm

Case Pin Drilling Diameter:

Up to 12" / 305 mm

Maximum Stroke:

12 - 16" / 305 - 406 mm



GeniSYS IV CNC Mill

Ideal for removal of cracked or broken studs and refurbishment of damaged threads. For hole diameters up to 11 inch and maximum 15.1 inch depths.

Page: 400

Casing Pin Drilling Machine



DDU1636

- Efficient pin drilling cold cut method
- Horseshoe mount options
- Helical drive spindle
- 4 inch (102 mm) cutter assembly supplied as standard
- Alternative cutter kits available up to 12 inch (305 mm).



Included as Standard with Each Machine

- Toolkit
- All required mounting legs and connections
- Storage/shipping box
- CE certificate
- Operator's Manual.
- Packing list.

Tapping & Casing Pin Drilling Machines

Maximum Diameter with Standard Drills		Maximum Standard Stroke		Casing Pin Drill Clamping Diameter		Machine Model Number	Drive Power Options	
(inch)	(mm)	(inch)	(mm)	(inch)	(mm)		Pneumatic	Hydraulic
3	76	12	305	-	-	T30	•	•
7¼	184	13	330	-	-	T725	•	•
12	305	16	406	9 - 24	228 - 609	DDU924		•
12	305	16	406	16 - 36	406 - 914	DDU1636		•

▼ DDU1636 casing pin drilling.



▼ GeniSYS™ IV CNC Mill

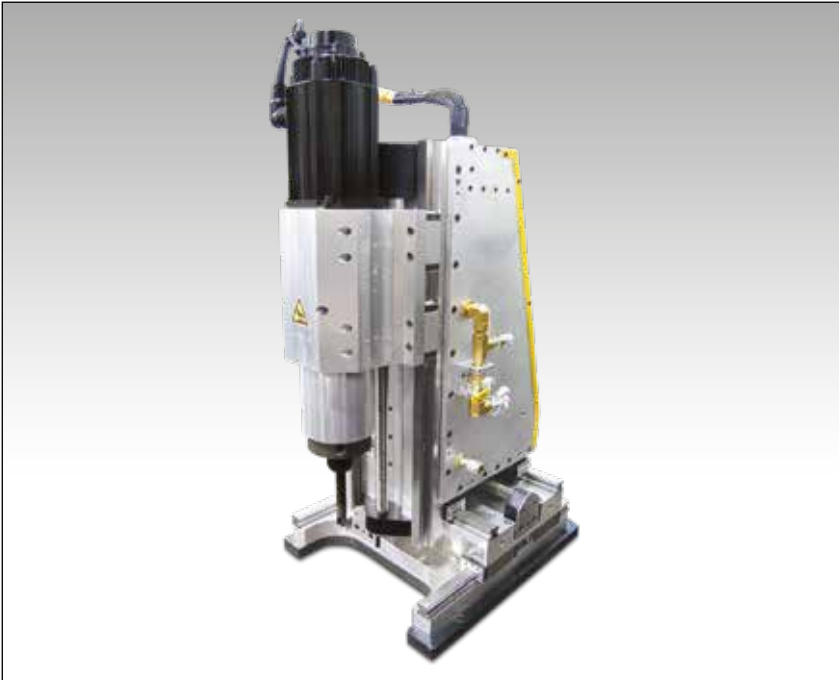

Removal of cracked or broken studs, refurbishment of damaged threads

- CNC software allows the geniSYS to be programmed to perform multiple tasks within its working envelope
- Can create bore and thread hole diameters ranging from 22,2 mm – 279,4 mm (0.875 – 11 inches)
- Hole depths up to 384 mm (15.12 inches)
- High tolerance profile rails produce consistent results
- All three axes utilize precision ground ball screws, providing precise movement of the milling head
- Accurate and repeatable machining
- A cold cutting operation
- Ejects chips during operation
- Single machine capable of drilling, threading and general milling applications.

▼ Thread cutting



GeniSYS IV On-site CNC Mill

The GeniSYS™ IV is a highly portable 3-axis CNC milling machine.

The motion control command center provides the ultimate in performance monitoring and technician safety.

Designed for the accurate removal of cracked or broken studs up to 11 inch diameter and the precise refurbishment of damaged threads. This is achieved without the need for manually controlled drilling or metal disintegration techniques.

Can be used for automated general profile milling applications.

Typical examples

- Manway covers
- Reactor studs
- Bolt extraction and threading applications
- Recirculation pumps
- Turbine cases
- Heat exchangers
- Motor bases and many more high impact assets.

▼ GeniSYS IV CNC Milling Machine.



GeniSYS™ IV On-site 3-axis CNC Milling Machine

GeniSYS

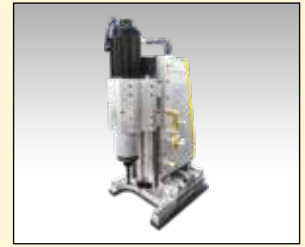

Hole Diameter:

7/8 - 11" / 22 - 279 mm

Hole Depths:

Up to 15.12" / 384 mm



▲ A typical thread before refurbishment



▲ New machined thread



▲ Enlarging a hole



▲ Coring out the centre of a bolt (minor diameter).



Included as Standard

The machine is supplied complete with the following items:

- GeniSYS IV milling machine
- Control System
- Laptop
- Motor and Cables
- Storage / Shipping Boxes
- Operator's Manual.



Tooling

Standard tooling packages available to support general milling and thread milling applications.

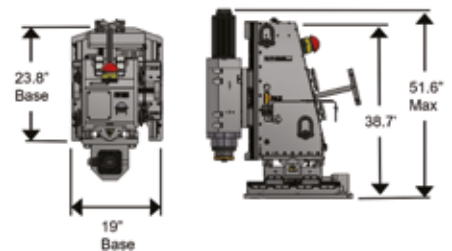

Dimensions GeniSYS IV

Base Length		Base Width		Total Height		Weight	
(inch)	(mm)	(inch)	(mm)	(inch)	(mm)	(lbs)	(kg)
23.8	605	19	483	51.6	1311	1100	499

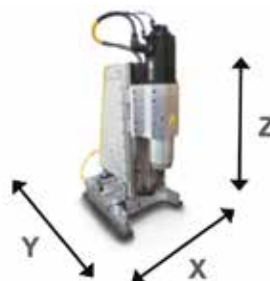

Specifications GeniSYS IV 3-axis CNC Milling Machine

Hole Diameters (Min. - Max.)		Machine Model Number	Maximum Hole Depth		Milling Head Maximum Travel						Spindle Speed (RPM)	Spindle Motor		Motor Voltage (Volt, 3 phase)
(inch)	(mm)		(inch)	(mm)	X-axis		Y-axis		Z-axis			(hp)	(kW)	
7/8 - 11	22,2 - 279,4	GeniSYS IV	15.12	384	8	203,2	8	203,2	17	431,8	3000	6.7	5,0	380 - 440

▼ Shown: MITT6A, MITT16A, MITT2A, MITT1A Isolation & Test Tools



Ultimate Versatility in Piping Isolation and Pressure Testing



Inline Isolation & Test Tools

MITT series tools obsolete traditional pipe cleaning and hydrotesting methods used for maintenance and construction operations.

Improve operator safety and reduce system downtime by eliminating cleaning requirements and limiting test pressure volume.

The MITT series tools improve safety by limiting the test pressure volume and reduce downtime by eliminating cleaning requirements.

Key benefits of the tools include:

- Significantly reduce maintenance project timelines
- Safely perform welding on hydrocarbon lines with the peace of mind of a positive pressurized hydrostatic isolation
- Achieve significant reduction in wastewater (<1,0 litres of water required for a 24 inch test)
- Patent Pending.

- **Combination Isolation and Test Tool assures vapor-free isolation for hot work and high-pressure capability between seals for testing welds with one tool**
- **Multi-schedule capability – up to 6 schedules covered per tool, 40 tools cover 154 pipe diameter / schedule combinations**
- **Lightweight, slim and versatile design – no crane required, able to mount in elbows and tees, able to test mismatched schedules**
- **High-pressure capability – test welds with relative ease up to 310 bar**
- **Self-centering tools are user-friendly and require minimal training**
- **Hydrodynamic capability for heat treating.**

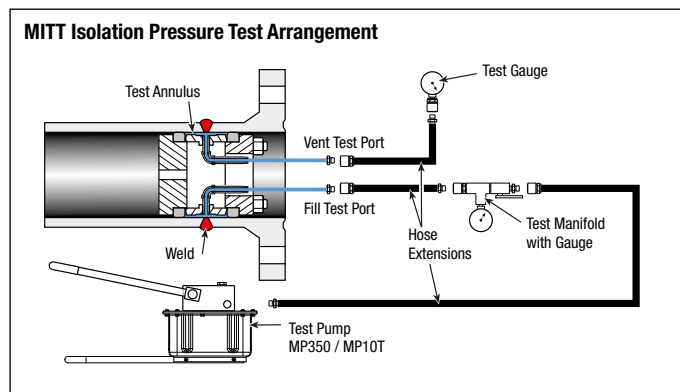
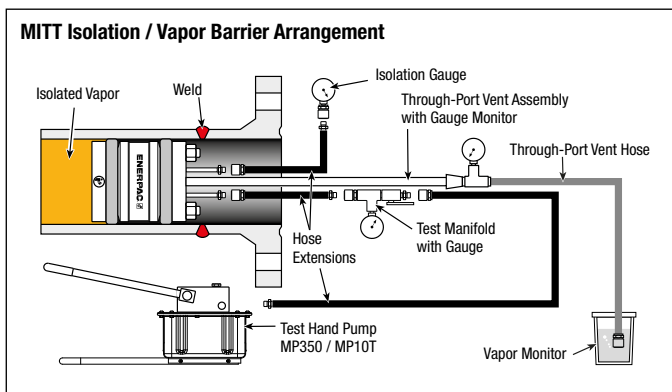

Nominal Pipe Diameter	Model Number	Pipe Schedules Covered	Max. Tool Pressure Rating	Tool Body Diameter	Overall Length	Stud, Nut, Washer Size	Pressure Port Size	
(inch)			(bar)	(mm)	(mm)	(inch)	(ASME NPT)	(kg)
3/4	MITT075A	5, 10, STD/40	310	18	356	1/8"	Female 1/8"	0,7
	MITT075B	XS/80, 160	310	15	356	1/8"	Female 1/8"	0,7
1	MITT1A	5, 10, STD/40	310	23	356	1/8"	Female 1/8"	0,9
	MITT1B	XS/80, 160	310	18	356	1/8"	Female 1/8"	0,7
1 1/4	MITT125A	5, 10, STD/40 XS/80	310	29	356	1/4"	Female 1/4"	1,3
1 1/2	MITT150A	5,10, XS/80	310	35	356	1/4"	Female 1/4"	1,9
	MITT150B	160	310	28	356	1/4"	Female 1/4"	1,5
2	MITT2A	5,10, STD/40, XS/80	310	46	356	1/4"	Female 1/4"	2,4
	MITT2B	160, XXS	310	37	356	1/4"	Female 1/4"	2,0
3	MITT3A	5,10, STD/40, XS/80	310	71	178	3/8"	Male 1/8"	2,3
	MITT3B	160, XXS	310	57	178	3/8"	Male 1/8"	2,0
4	MITT4A	5,10, STD/40, 60, XS/80	310	94	178	5/16"	Male 1/8"	2,5
	MITT4B	120, 160	310	81	178	5/16"	Male 1/8"	2,2
	MITT4C	XXS	310	77	178	5/16"	Male 1/8"	1,9
6	MITT6A	10, STD/40, 60	310	145	178	5/8"	Male 1/4"	5,9
	MITT6B	XS / 80, 120	310	137	178	5/8"	Male 1/4"	5,4
	MITT6C	160, XXS	310	122	178	5/8"	Male 1/4"	4,5
8	MITT8A	10, 20, 30, STD/40, XS/80	310	189	178	5/8"	Male 1/4"	8,6
	MITT8B	100, 120, 140, XXS, 160	310	168	178	5/8"	Male 1/4"	7,3
10	MITT10A	20, 30, STD/40, XS/60, 80	310	238	178	5/8"	Male 1/4"	13,2
	MITT10B	100, 120, XXS/140, 160	310	213	178	5/8"	Male 1/4"	11,3
12	MITT12A	10, 20, 30, STD, 40, XS	310	294	178	5/8"	Male 1/4"	19,5
	MITT12B	60, 80, 100, XXS/120	310	272	178	5/8"	Male 1/4"	18,6
	MITT12C	140, 160	310	248	178	5/8"	Male 1/4"	14,5
14	MITT14A	10, 20, STD/30, 40	310	324	178	5/8"	Male 1/4"	20,4
	MITT14B	XS, 60, 80	310	324	178	5/8"	Male 1/4"	19,1
	MITT14C	100, 120, 140, 160	310	283	178	5/8"	Male 1/4"	17,2
16	MITT16A	10, 20, STD/30, XS/40, 60	310	372	178	5/8"	Male 1/4"	24,5
	MITT16B	80, 100	310	344	178	5/8"	Male 1/4"	21,8
	MITT16C	120, 140, 160	310	324	178	5/8"	Male 1/4"	20,4
18	MITT18A	10, 20, STD, 30, XS, 40	310	419	178	5/8"	Male 1/4"	29,0
	MITT18B	60, 80	310	400	178	5/8"	Male 1/4"	27,2
	MITT18C	100, 120	310	378	178	5/8"	Male 1/4"	24,9
	MITT18D	140, 160	310	357	178	5/8"	Male 1/4"	23,6
20	MITT20A	10, STD/20, XS / 30	310	480	178	5/8"	Male 1/4"	36,3
	MITT20B	40, 60	310	457	178	5/8"	Male 1/4"	33,1
	MITT20C	80, 100	310	433	178	5/8"	Male 1/4"	30,4
	MITT20D	120, 140	310	410	178	5/8"	Male 1/4"	27,7
	MITT20E	160	310	399	178	5/8"	Male 1/4"	27,2
22	MITT22A	STD, XS	310	524	178	5/8"	Male 1/4"	40,4
	MITT22B	60, 80	310	492	178	5/8"	Male 1/4"	36,7
	MITT22C	100, 120	310	467	178	5/8"	Male 1/4"	34,0
	MITT22D	140, 160	310	441	178	5/8"	Male 1/4"	31,3
24	MITT24A	10, STD/20, XS, 30	79	575	178	5/8"	Male 1/4"	44,9
	MITT24B	40, 60	155	551	178	5/8"	Male 1/4"	42,6
	MITT24C	80, 100	232	522	178	5/8"	Male 1/4"	39,9
	MITT24D	120, 140	310	495	178	5/8"	Male 1/4"	37,2
	MITT24E	160	310	480	178	5/8"	Male 1/4"	36,3
26	MITT26A	10, STD, XS	79	626	178	5/8"	Male 1/4"	52,2
30	MITT30A	10, STD, XS/20, 30	79	727	178	5/8"	Male 1/4"	66,7
	MITT30B	40	79	714	178	5/8"	Male 1/4"	63,5
32	MITT32A	10, STD, XS/20, 30	79	778	178	5/8"	Male 1/4"	71,7
	MITT32B	40	79	768	178	5/8"	Male 1/4"	70,3
34	MITT34A	10, STD, XS/20, 30	29	829	178	5/8"	Male 1/4"	76,2
	MITT34B	40	29	819	178	5/8"	Male 1/4"	74,8
36	MITT36A	10, STD, XS	29	879	178	5/8"	Male 1/4"	84,8
38	MITT38A	STD, XS	29	930	178	5/8"	Male 1/4"	94,3
40	MITT40A	STD, XS	29	981	178	5/8"	Male 1/4"	104,3

MITT Series



Pipe Diameters:

3/4 - 40 inch

Water Capacity per Test:

0,4 - 3,0 litres

Maximum Test Pressure:

310 bar



Cost-Effective Spares

Buna 90 shore hardness seals and stainless steel seal backing rings provide additional pressure capacity for a low cost.



Ancillary Kit – MITTAK

All ancillary components required to safely isolate piping and test new welds (includes manual valves, gauge set, hoses, hand tools, fittings).



Pump and Reservoir

To match the full capability of the tools, the **MP350** hand pump and **MP10T** reservoir are recommended.

Page: **82**

▼ MITT2A tool being torqued in a test stand for high pressure testing.





Enerpac 'Yellow Pages' stand for Hydraulic Information!

If selecting hydraulic equipment is not your daily routine, then you will appreciate these pages. The 'Yellow Pages' are designed to help you work with hydraulics. They will help you to better understand the basics of hydraulics, of system set-ups and of the most commonly used hydraulic techniques. The better your choice of equipment, the better you will appreciate hydraulics. Take the time to go through these 'Yellow Pages' and you will benefit even more from Enerpac High Pressure Hydraulics.



ENERPAC WARRANTY STATEMENT

Visit our website for the complete Global Lifetime Warranty or call your Authorized Service Center.



Learn more about hydraulics

Visit www.enerpac.com to learn more about hydraulics and system set-ups.

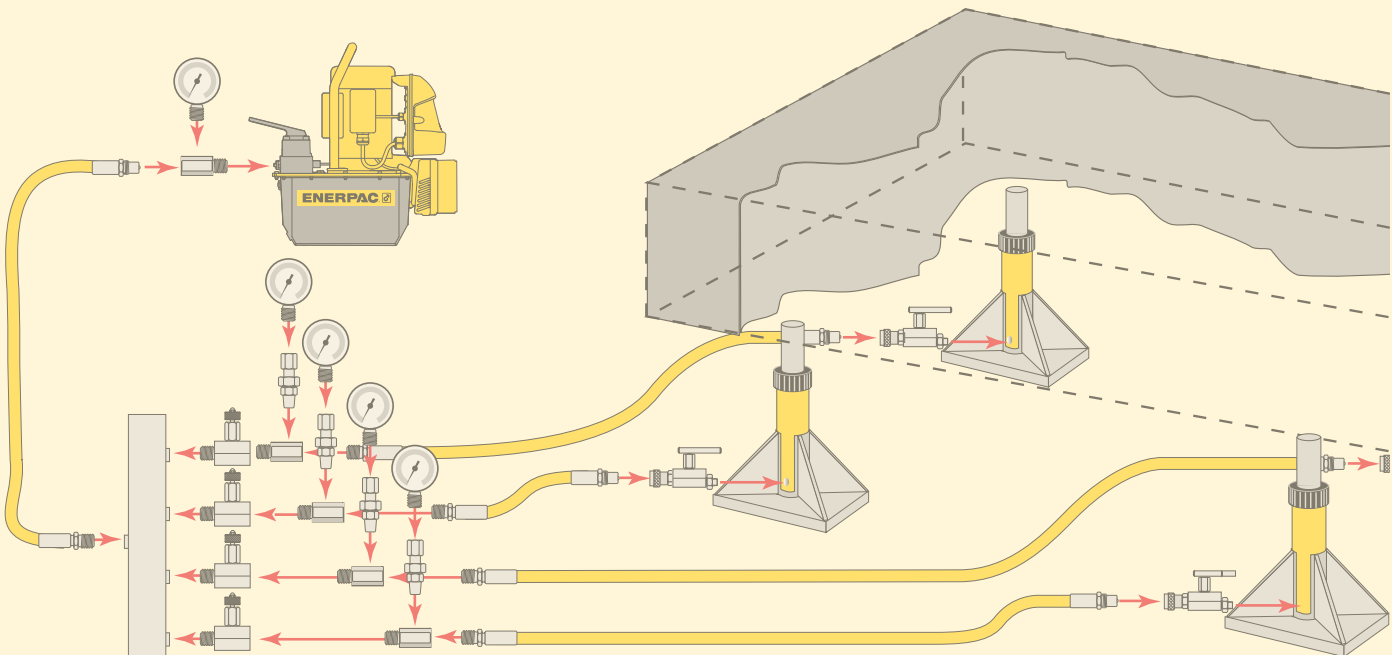
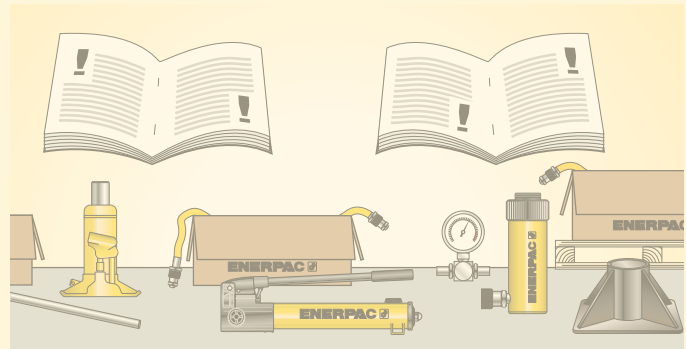



Section		Page
Safety Instructions		406 ▶
Pump Selection Selection Worksheet		408 ▶ 409 ▶
Basic System Set-ups		410 ▶
Basic Hydraulics		412 ▶
Conversion Tables Cylinder Speed Charts		414 ▶ 415 ▶
Valve Information Hexagon Bolt and Nut Sizes		416 ▶ 417 ▶
Torque Tightening Tensioning		418 ▶ 420 ▶
INFORMATE Bolting Integrity Software		412 ▶
Enerpac Academy & Enerpac Maintenance Program (EMP)		424 ▶

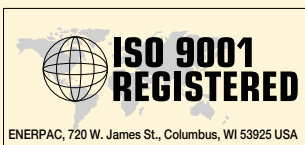

Enerpac is certified for several quality standards. These standards require compliance with standards for management, administration, product development and manufacturing. Enerpac worked hard to earn the quality rating ISO 9001, in its ongoing pursuit of excellence.

DIN-ISO 1402

Enerpac Thermoplastic and Rubber Hoses have been tested and confirm to this Standard.

ASME B30.1-2015

Our cylinders fully comply with the criteria set forth by the American National Standards Institute (except RD, BRD, HCL, LPL, CUSP and JHA-Series).

Product Design Criteria

All hydraulic components are designed and tested to be safe for use at max. 700 bar (10.000 psi) pressure unless otherwise specifically noted.



Where specified, Enerpac electric power units meet the design, assembly and test requirements of the Standards Council of Canada (CAN C22.2 No. 68-92), and UL73 for the United States. Units were tested and certified for both USA and Canada by TÜV and by CSA, USA-OSHA-NRTLs., (Nationally Recognised Testing Laboratories).

EMC Directive

Where specified, Enerpac electric power pumps meet the requirements for Electromagnetic Compatibility per EMC Directive 2014/30/EU.



CE Marking & Conformity

Enerpac provides Declarations of Conformity or Incorporation, as applicable, and CE Marks for products according to the EU Directives.



ATEX 95 Certified

The S, W, DSX and HMT-Series torque wrenches, ZA, XA, LAT and ATP-Series air driven pumps, SWi-Ex-flange spreaders, HP-Ex hand pumps and the 144-type hoses are tested and certified to conform to the Directive 2014/34/EU "ATEX Directive".

The explosion protection is for Equipment Group II, Equipment Category 2 (Hazardous Zone Area 1) in Gas and/or Dust atmospheres.

S, W-wrenches:	Ex II 2 GD T4
DSX, HMT-wrenches:	Ex II 2 G c T6
NSH-Nut Splitters:	Ex II 2 G c T6
ZA4, ZA4T-Air Pumps:	Ex II 2 GD ck T4
ZA4TX-QROP-Pump:	Ex IIC T4 Gc Ex IIIC T135°C Dc
ATP, XA-Air Pumps:	Ex II 2 GD ck T4
LAT-Air Pumps:	Ex IIC T4 Gc and Ex IIIC T135°C Dc
SWi-Ex Spreaders:	II 2G Ex h IIB T5 Gb and II 2D Ex h IIIC T85°C Db
HP-Ex Hand Pumps:	II 2G Ex h IIB T5 Gb and II 2D Ex h IIIC T100°C Db
144-Hoses:	II 2G Ex h IIB T5 Gb and II 2D Ex h IIIC T100°C Db



Safety Instructions



When used correctly, hydraulic power is one of the safest methods of applying force to your work. And to that end we offer some DO's and

DON'Ts, simple common sense points which apply to practically all Enerpac hydraulic products.

- Lift slowly and check the load often
- Avoid standing in the line of force
- Anticipate possible problems and take steps to avoid them.

The line drawings and application photo's of Enerpac products throughout this catalog are used to portray how some of our customers have used hydraulics in industry.

In designing similar systems, care must be taken to select the proper components that provide safe operation and fit your needs.

Check to see if all safety measures have been taken to avoid the risk of injury and property damage from your application or system.

Enerpac can not be held responsible for damage or injury, caused by unsafe use, maintenance or application of its products.

Please contact the Enerpac office or a representative for guidance when you are in doubt as to the proper safety precautions to be taken in designing and setting up your particular system.

In addition to these tips, every Enerpac product comes with instructions spelling out specific safety information. Please read them carefully.

Jacks

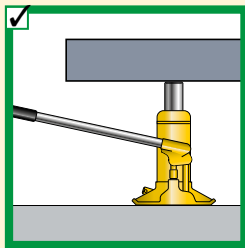
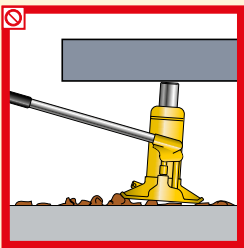

Provide a level and solid support for the entire jack base area.

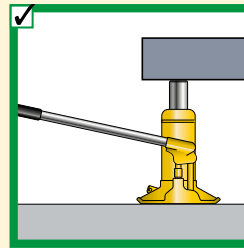
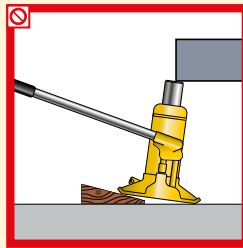

The entire jack saddle must be in contact with the load. Movement of the load to be in the same direction as jack plunger.



Never place any part of your body under the load. Ensure the load is on a solid support before venturing under.

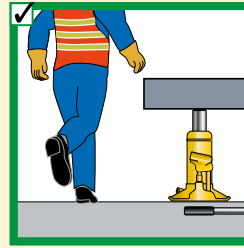
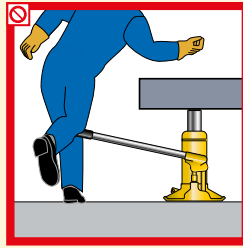

Remove the jack handle when it is not being used.

Cylinders

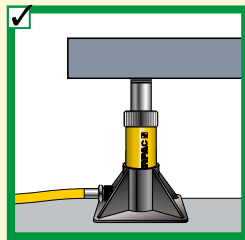
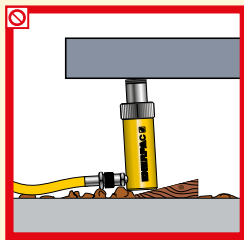

Provide a solid support for the entire cylinder base area. Use cylinder base attachment for more stability.

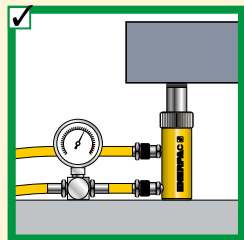
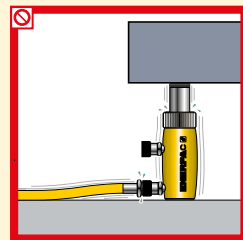

Both couplers must be connected when using double-acting cylinders. Ensure return hose is fitted.

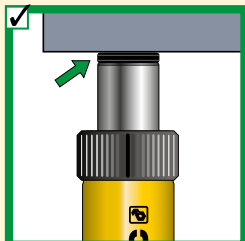
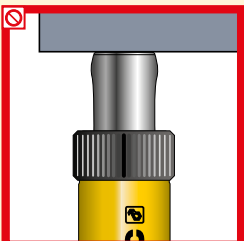

Do not use cylinder without saddle. This will cause plunger to "mushroom". Saddles distribute load evenly on the plunger.



As with jacks, never place any part of your body under the load. Load must be on cribbing before venturing under.



Always protect cylinder threads for use with attachments.

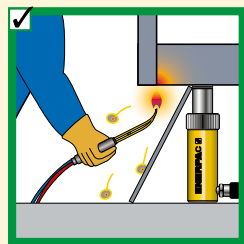

Keep hydraulic equipment away from open fire and temperatures above 65 °C (150 °F).



General

**Manufacturer's rating of load and stroke are maximum safe limits.
Good practice encourages using only 80% of these ratings!**

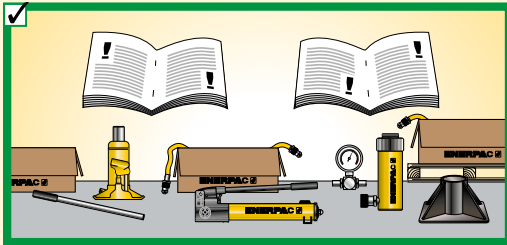

Always read instructions and safety warnings that come with your Enerpac hydraulic equipment.

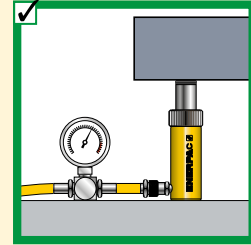
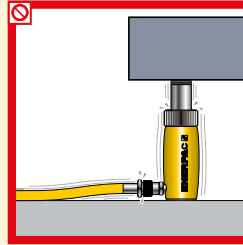

Don't override the factory setting of relief valves. Always use a gauge to check system pressure.

Pumps

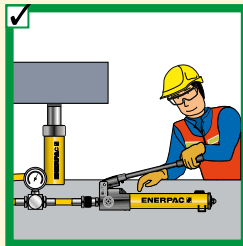
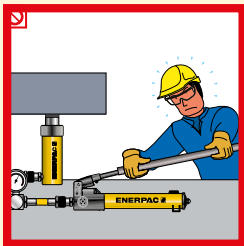

Don't use handle extenders. Hand pumps should be easy to operate when used correctly.

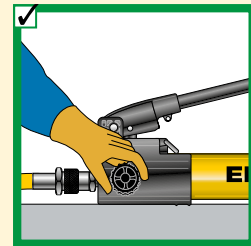
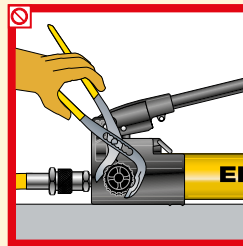

Close release valve finger tight. Using force will ruin the valve.

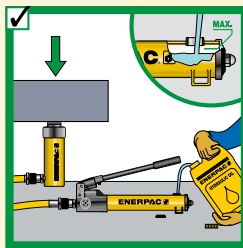
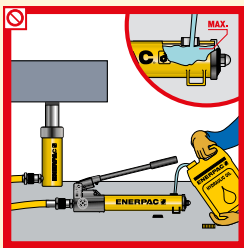

Fill pump only to recommended level. Fill only when connected cylinder is fully retracted.

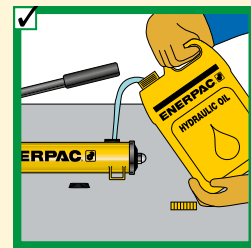
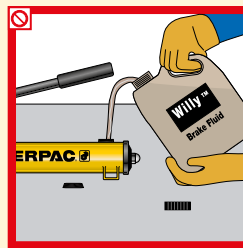

Use only genuine Enerpac hydraulic oil. Wrong fluid can destroy seals and pump and will render your warranty null and void your guarantee.

Hoses and couplers

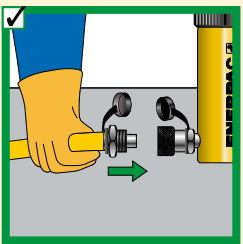
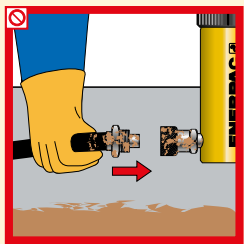

Clean both coupler parts before connecting. Use dust caps when coupler parts are not connected.

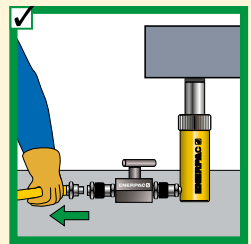
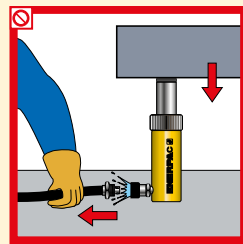

Detach cylinder only when fully retracted or use shut-off valves or safety valves to lock-in cylinder pressure.

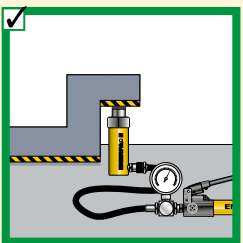
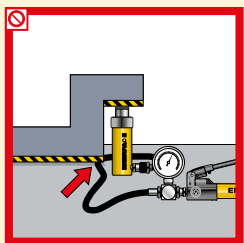

Keep hoses away from the area beneath loads.

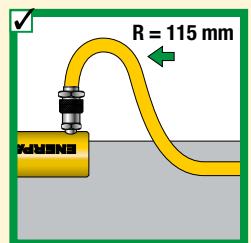
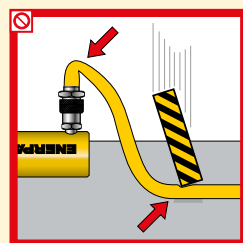

Don't kink hoses. Bending radius should be at least 115 millimetres. Don't drive over or drop heavy objects on hoses.

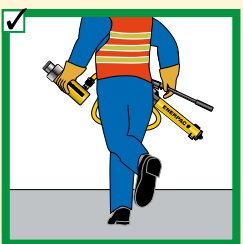
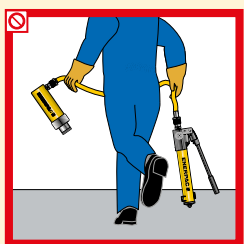

Don't lift hydraulic equipment by the hoses.

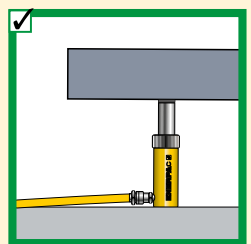
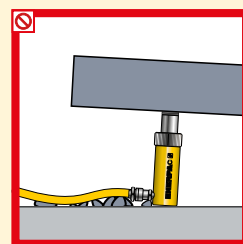

Never allow the cylinder to be lifted off the ground through the couplers.



▼ HAND PUMP AND SINGLE-ACTING CYLINDER MATCHING CHART

Capacity (ton) ▶	5 t	10 t	15 t	25 t	30 t	50 t	60 t	75 t	100 t	150 t
▼ Stroke										
< 25 mm										
25 mm										
50 mm										
75 mm										
100 mm										
125 mm										
150 mm										
175 mm										
200 mm										
225 mm										
250 mm										
300 mm										
325 mm										
350 mm										
		P392			P80		P462			
		Page: 76			Page: 78		Page: 78			

Note: Selection based on oil capacity requirements of cylinders.

▼ POWER PUMP SELECTION CHART

Oil Flow *	Low Oil Flow (0,1 - 0,3 l/min)		Medium Oil Flow (0,5 - 2,0 l/min)		High Oil Flow (2,0 - 4,2 l/min)	
Oil Capacity	1,9 - 3,8 litres	3,0 litres	4,6 - 39 litres	4,6 - 39 litres	9,8 - 39 litres	9, 20, 135 litres
Duty Cycle **	Intermittent	Extended	Intermittent	Extended	Extended	Extended
Portability ***	Portable	Portable	Portable	Stationary	Stationary	Stationary
Recommended Series	PU-Series Economy	E-Series E-Pulse®	ZU4-Series	ZE3-, ZE4- and ZE5-Series	ZE6-Series	SFP-Series Split-Flow
	Page: 90	Page: 94	Page: 98	Page: 104	Page: 104	Page: 344

*** Oil Flow**

- Determined by motor size
- Directly affects electrical power requirements
- Determines cylinder or tool speed

**** Duty Cycle**

- Extended applications require more than one hour of uninterrupted pump use
- Intermittent would be used less than one hour, depending on reservoir capacity.

***** Portability**

- | | |
|---|---|
| <p>Portable</p> <ul style="list-style-type: none"> • Ergonomic handles • Flexible power requirements | <p>Stationary</p> <ul style="list-style-type: none"> • Mounting options • Normally requires stable power |
|---|---|



▼ Complete the following information to select the right products:

Cylinder Selection	Question:	Tips/help	Data	Model Number
	Total force required (ton):	Total load	<input style="width: 100px; height: 20px;" type="text"/>	
	Number of cylinders required:	Number of lifting points	<input style="width: 100px; height: 20px;" type="text"/>	
	Force per cylinder (ton):	Should be 80% of total cylinder capacity	<input style="width: 100px; height: 20px;" type="text"/>	
	Stroke required:	Plunger travel	<input style="width: 100px; height: 20px;" type="text"/>	
	Single or double-acting (D/A):	D/A used when pull force is required, or retract speed is critical	<input style="width: 100px; height: 20px;" type="text"/>	
	Type of plunger required:	Hollow or solid	<input style="width: 100px; height: 20px;" type="text"/>	
	Collapsed height required:		<input style="width: 100px; height: 20px;" type="text"/>	
	Optional saddle required:	Tilt, Grooved, Flat	<input style="width: 100px; height: 20px;" type="text"/>	
	Cylinder base:	Improves stability	<input style="width: 100px; height: 20px;" type="text"/>	
	Cylinder attachments: (RC-series)	Expanded functions	<input style="width: 100px; height: 20px;" type="text"/>	
Selected cylinder model:			▶	<input style="width: 100px; height: 20px;" type="text"/>
Including coupler model:			<input style="width: 100px; height: 20px;" type="text"/>	

Pump Selection

The three most commonly selected pumps are hand pumps, electric pumps and air-driven pumps. Gas powered pumps, however can be selected in the same way.

Available power source: Manual Battery Electric Compressed Air Petrol

Hand Pump	Not for high cycle applications	<input style="width: 100px; height: 20px;" type="text"/>
Single- or double-acting operation	Use 4-way valve for D/A applications Check speed chart on page 415 for number of mm per stroke)	<input style="width: 100px; height: 20px;" type="text"/>

Selected Hand Pump:	▶	<input style="width: 100px; height: 20px;" type="text"/>
----------------------------	---	--

Electric or Compressed Air Pump		
Need for portability:		<input style="width: 100px; height: 20px;" type="text"/>
Duty cycle:	Intermittent or extended	<input style="width: 100px; height: 20px;" type="text"/>
Required useable oil capacity:	Intermittent = 1,2 x oil capacity high cycle = 2 x oil capacity	<input style="width: 100px; height: 20px;" type="text"/>
Available Voltage:		<input style="width: 100px; height: 20px;" type="text"/>
Lifting speed (Important/not important):	Use speed chart on page 415	<input style="width: 100px; height: 20px;" type="text"/>
Type of control:	Manual / remote pendant	<input style="width: 100px; height: 20px;" type="text"/>
Type of actuation/function:	Advance / Hold / Retract	<input style="width: 100px; height: 20px;" type="text"/>
Accessories:	Filter Kit, Level Switch, Roll Bar ...	<input style="width: 100px; height: 20px;" type="text"/>

Selected Pump:	▶	<input style="width: 100px; height: 20px;" type="text"/>
-----------------------	---	--

Including Coupler:	Oil connection	<input style="width: 100px; height: 20px;" type="text"/>
---------------------------	----------------	--

System Components

Number of hoses and length required:	<input style="width: 100px; height: 20px;" type="text"/>
---	--

Selected Hoses:	▶	<input style="width: 100px; height: 20px;" type="text"/>
------------------------	---	--

Manifold or Tee-fitting:	▶	<input style="width: 100px; height: 20px;" type="text"/>
Extra hose per manifold (2):	▶	<input style="width: 100px; height: 20px;" type="text"/>
Gauge (kN or bar scale):	▶	<input style="width: 100px; height: 20px;" type="text"/>
Gauge Adapter:	▶	<input style="width: 100px; height: 20px;" type="text"/>
Fittings:	▶	<input style="width: 100px; height: 20px;" type="text"/>
Pressure Relief Safety Valve:	▶	<input style="width: 100px; height: 20px;" type="text"/>
Load-holding Valve(s):	▶	<input style="width: 100px; height: 20px;" type="text"/>
Hydraulic Oil:	▶	<input style="width: 100px; height: 20px;" type="text"/>



1 Cylinder
Applies hydraulic force.
Page 5

2 Cylinder Base Plate
For applications like lifting where additional cylinder stability is required.
Page 10

3 Pump
Provides hydraulic flow.
Page 75

4 Hose
Transports hydraulic fluid.
Page 128-129

5 Male Coupler
For quick connection of the hose to system components.
Page 130-131

6 Female Coupler
For quick connection of the hose end to the system components.
Page 130-131

7 Gauge
To monitor pressure of the hydraulic circuit.
Page 136-142

8 Gauge Adaptor
For quick and easy gauge installation.
Page 142-143

9 Swivel Connector
Allows proper alignment of valves and/or gauges. Used when units being connected cannot be rotated.
Page 143

10 Auto-Damper Valve V10
Used to protect gauge from damage due to sudden pressure pulses in the system. Needs no adjustment and allows correct positioning of gauge, prior to tightening.
Page 144-145

11 4-Way Directional Control Valve
Controls the direction of hydraulic fluid in a double-acting system.
Page 122-123

Single-acting push application, such as in a press.

The hand pump offers controlled cylinder advance, but may require many hand pump strokes in longer stroke applications when the cylinder capacity is 25 ton or above.

Examples of pump, hose and cylinder sets can be found on pages 62-65.

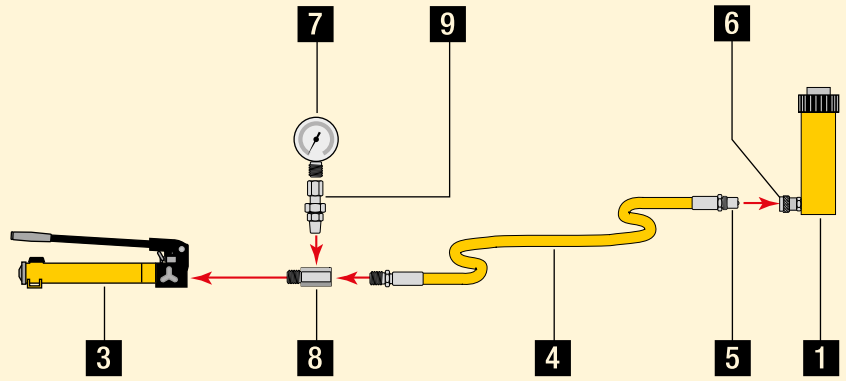

Single-acting cylinder with longer stroke used for lifting applications.

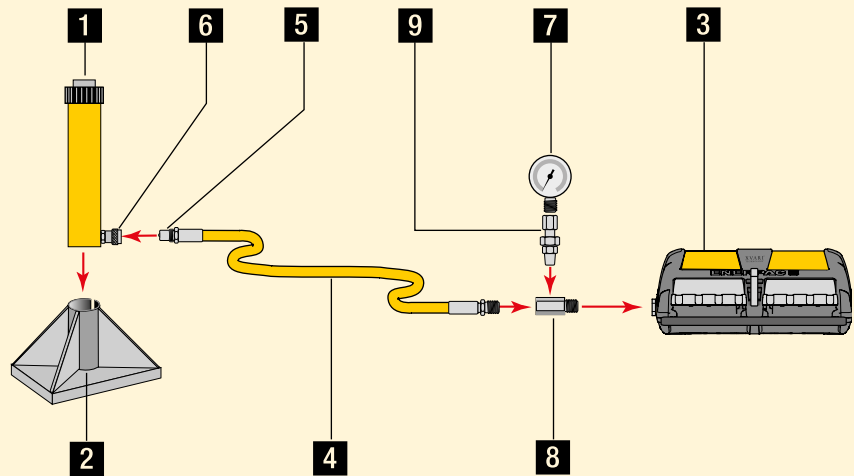

Double-acting cylinder set-up used for lifting applications where a slow controlled descent of the load must be maintained.

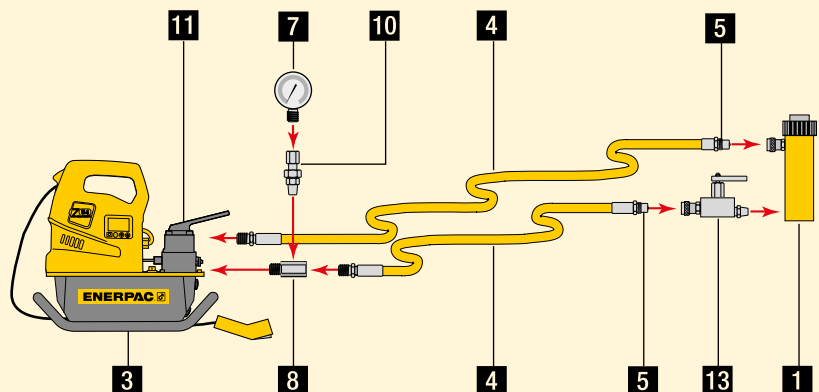



Double-acting cylinder set-up used in a push/pull application.

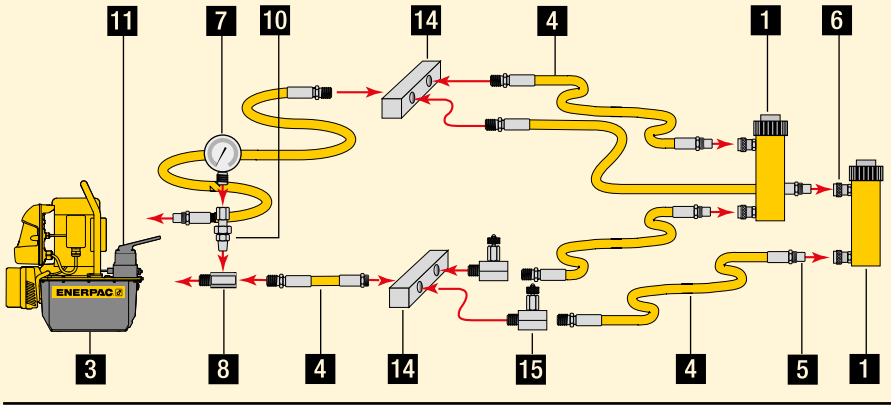

12 3-Way Directional Control Valve
Controls the direction of hydraulic fluid in a single-acting system.
Page 122-123

13 Safety Holding Valve V66
Controls load descent in lifting applications.
Page 144-145

14 Manifold
Allows distribution of hydraulic fluid from one power source to several cylinders.
Page 132-135

15 Needle valves V82 and V182
Regulates the flow of hydraulic fluid to or from the cylinders.
Page 144-145

Two point lifting set-up using single-acting cylinders.

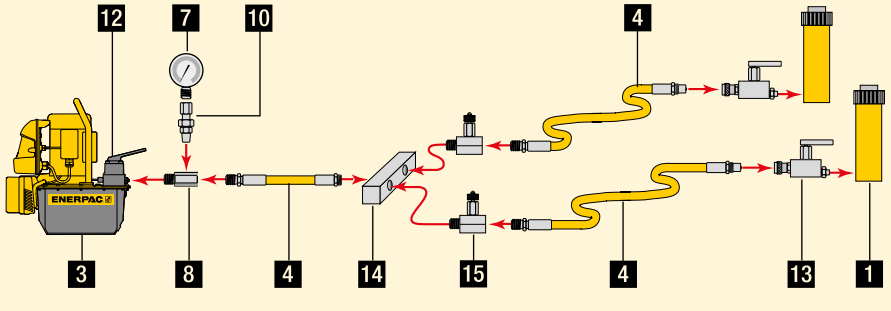

Four point lifting set-up, using single-acting cylinders and directional control valves.

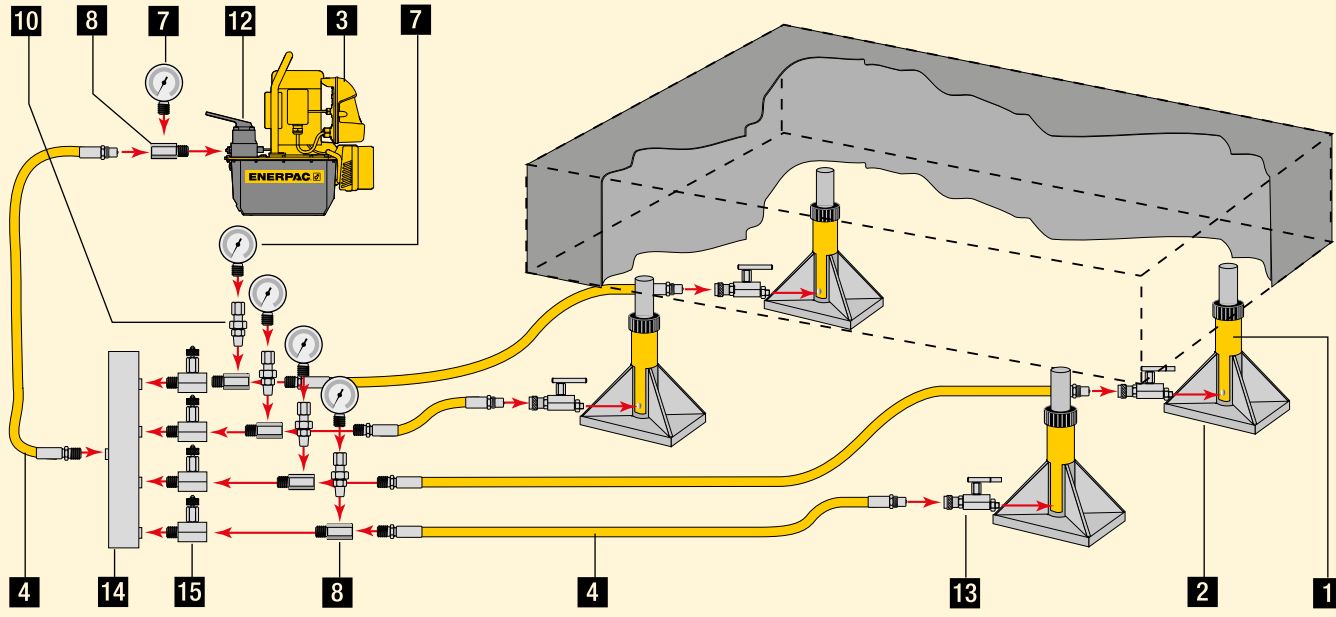



www.enerpac.com
Visit our web site to learn more about hydraulics and system set-ups.



Flow

A hydraulic pump produces flow.

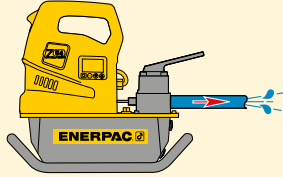

Pressure

Pressure occurs when there is resistance to flow.

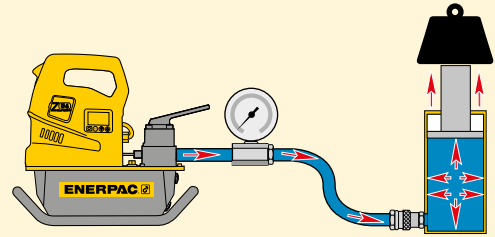

Pascal's Law

Pressure applied at any point upon a confined liquid is transmitted undiminished in all directions (Fig.1). This means that when more than one hydraulic cylinder is being used, each cylinder will lift at its own rate, depending on the force required to move the load at that point (Fig. 2).

Cylinders with the lightest load will move first, and cylinders with the heaviest load will move last (Load A), as long as the cylinders have the same capacity.

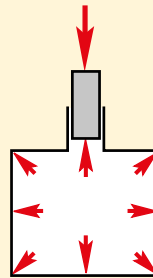
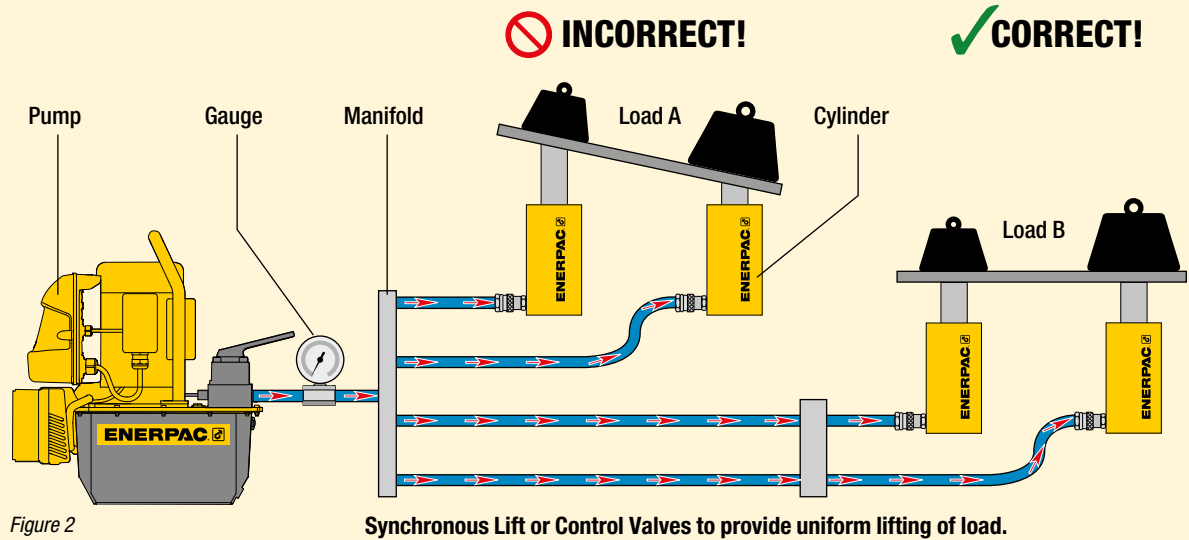

Figure 1

To have all cylinders operate uniformly so that the load is being lifted at the same rate at each point, either control valves (see Valve section) or Synchronous Lift System components (see section Heavy Lifting Technology) must be added to the system (Load B).



CAUTION!
When lifting or pressing, always use a gauge.

A gauge is your 'window' to the system. It lets you see what's going on. You will find the gauges in the System Components section.



Learn more about hydraulics
Visit www.enerpac.com to learn more about hydraulics and system set-ups.



Force

The amount of force a hydraulic cylinder can generate is equal to the hydraulic pressure times the “effective area” of the cylinder (see cylinder selection charts).

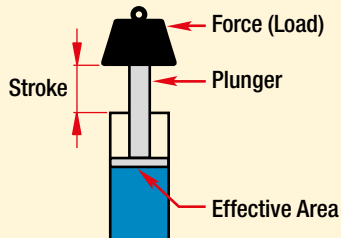

Force	=	Hydraulic Working Pressure	x	Cylinder Effective Area
F	=	P	x	A

Use this formula to determine either force, pressure or effective area if two of the variables are known.

Example 1

An RC106 cylinder with 14,5 cm² effective area operating at 700 bar * will generate what force?

Force = 7000 N/cm² x 14,5 cm² = 101500 N = 101,5 kN

* Note: 700 bar = 700 x 10⁵ N/mm² = 7000 N/cm².

Example 2

An RC106 cylinder lifting 7000 kg will require what pressure?

Pressure = 7000 x 9,8 N ÷ 14,5 cm² = 4731,0 N/cm² = 473 bar.

Example 3

An RC256 cylinder is required to produce a force of 190.000 N. What pressure is required?

Pressure = 190.000 N ÷ 33,2 cm² = 5722,9 N/cm² = 572 bar.

Example 4

Four RC308 cylinders are required to produce a force of 800.000 N. What pressure is required?

Pressure = 800.000 N ÷ (4 x 42,1 cm²) = 4750,6 N/cm² = 476 bar.

Remember, since four cylinders are used together, the area for one cylinder must be multiplied by the number of cylinders used.

Example 5

A HCL2506 cylinder is going to be used with a power source that is capable of 500 bar. What is the theoretical force available from that cylinder?

Force = 5000 N/cm² x 363,1 cm² = 1.815.500 N = 1815 kN.

Cylinder Oil Capacity

The volume of oil required for a cylinder (cylinder oil capacity) is equal to the effective area of the cylinder times the stroke*.

Cylinder Oil Capacity	=	Cylinder Effective Area	x	Cylinder Stroke
------------------------------	---	--------------------------------	---	------------------------

* Note: these are theoretical examples and do not take into account the compressibility of oil under high pressure.

Example 1:

An RC158 cylinder with 20,3 cm² effective area and 200 mm stroke requires what volume of oil?

Oil Capacity = 20,3 cm² x 20 cm = 406 cm³

Example 2:

An RC5013 cylinder has an effective area of 71,2 cm² and a stroke of 320 mm. How much oil will be required?

Oil Capacity = 71,2 cm² x 32 cm = 2278,4 cm³

Example 3:

An RC10010 cylinder has an effective area of 133,3 cm² and a stroke of 260 mm. How much oil will it require?

Oil Capacity = 133,3 cm² x 26 cm = 3466 cm³

Example 4:

Four RC308 cylinders are being used, each with an effective area of 42,1 cm² and a stroke of 209 mm. How much oil will be required?

Oil Capacity = 42,1 cm² x 20,9 cm = 880 cm³ for one cylinder

Multiply by four to obtain the required capacity: 3520 cm³

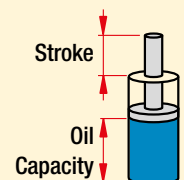

CAUTION!

Enerpac oil will compress 2,28% at 350 bar and 4,1% at 700 bar.



Key to cylinder dimensions

Dimensions shown in the Selection Charts of the cylinder section are identified on the relevant drawings by the capital letter references listed here: A for collapsed height through Z1 for depth of internal base thread.

- | | |
|---|---------------------------------------|
| A = Collapsed height | L = Plunger centre to side of base |
| B = Extended height | M = Mounting holes to plunger centre |
| C = Cylinder body length | N = Length of smaller cylinder part |
| D = Cylinder outside diameter | O = Plunger hole or thread of saddle |
| D1 = Cylinder width | P = Plunger thread length |
| E = Cylinder inside diameter | Q = Plunger outside thread |
| F = Plunger rod diameter | U = Pitch (BC) of mounting holes |
| G = Oil inlet thread | V = Thread of cylinder mounting holes |
| H = Cylinder bottom to advance port | W = Collar thread |
| I = Cylinder top to retract port | X = Collar thread length |
| J = Saddle outside diameter | Y = Centre hole diameter |
| K = Cylinder rod protrusion at collapsed height | Z = Internal base thread |
| | Z1 = Depth of internal base thread |

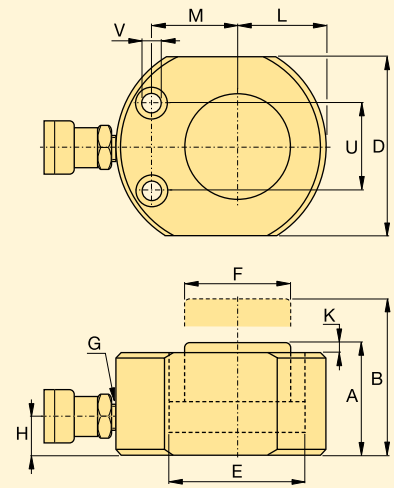
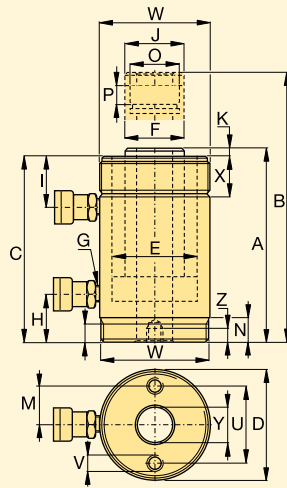

Key to measurements

All capacities and measurements in the catalogue are expressed in uniform values.

The conversion chart provides helpful information for their translation into equivalent systems.

All ton values specified in this catalogue are metric tonnes and are for cylinder class identification only.

Please refer to the kN data for calculations.

Free Conversion Calculator

Visit enerpac.com and download the free conversion calculator.

Pressure:

- | | |
|-------|-------------------------|
| 1 psi | = 0,069 bar |
| 1 bar | = 14,50 psi |
| | = 9,8 N/cm ² |
| | = 100.000 Pa |
| 1 kPa | = 0,145 psi |
| 1 MPa | = 145 psi |

Volume:

- | | |
|-------------------|--------------------------|
| 1 in ³ | = 16,387 cm ³ |
| 1 cm ³ | = 0,061 in ³ |
| 1 litre | = 61,02 in ³ |
| | = 0,264 gal |
| 1 USgal | = 3785 cm ³ |
| | = 3,785 l |
| | = 231 in ³ |

Weight:

- | | |
|---------------|-------------|
| 1 pound (lb) | = 0,4536 kg |
| 1 kg | = 2,205 lbs |
| | = 9,806 N |
| 1 metric ton | = 2205 lbs |
| | = 1000 kg |
| 1 ton (short) | = 2000 lbs |
| | = 907,18 kg |

Torque:

- | | |
|----------|----------------|
| 1 Nm | = 0,738 Ft.lbs |
| | = 0,102 kgf.m |
| 1 Ft.lbs | = 1,356 Nm |
| | = 0,138 kgf.m |

Temperature:

To Convert °C to °F:

$$T^{\circ F} = (T_{\circ C} \times 1,8) + 32$$

To Convert °F to °C:

$$T^{\circ C} = (T_{\circ F} - 32) \div 1,8$$

Other measurements:

- | | |
|-------------------|-------------------------|
| 1 in | = 25,4 mm |
| 1 mm | = 0,039 in |
| 1 in ² | = 6,452 cm ² |
| 1 cm ² | = 0,155 in ² |
| 1 hp | = 0,746 kW |
| 1 kW | = 1,359 hp |
| 1 kN | = 225 lbs |

Imperial to metric

Inches	Decimal	mm
1/16	.06	1,59
1/8	.13	3,18
3/16	.19	4,76
1/4	.25	6,35
5/16	.31	7,94
3/8	.38	9,53
7/16	.44	11,11
1/2	.50	12,70
9/16	.56	14,29
5/8	.63	15,88
11/16	.69	17,46
3/4	.75	19,05
13/16	.81	20,64
7/8	.88	22,23
15/16	.94	23,81
1	1.00	25,40

Cylinder Speed Charts



Cylinder Speed

This chart will help you calculate the time required for an Enerpac cylinder to lift a load when powered by a 700 bar Enerpac hydraulic pump.

The Cylinder Speed Chart can also be used to determine the pump type and model best suited for an application when you know the plunger speed required.

To determine: Cylinder plunger speed

An RC256 cylinder (25 ton) is powered by a ZE3-Series two stage pump. While lifting the load, the cylinder plunger travels at 2,8 mm per second. While extending towards the load, the cylinder plunger travels at 30,9 mm per second.

To determine: Best matching pump

Your 25 ton cylinder needs to move a load at a speed of 3,0 mm per second. Simply go down from the top of the chart, to the value of 2,8 mm per second. Follow the chart to the right to find that the ZE3-Series pump is most suitable for your application.

Millimetres of RC-Series cylinder plunger travel per hand pump plunger stroke

Cyl. Capacity ▶	5 ton		10 ton		15 ton		25 ton		30 ton		50 ton		75 ton		100 ton		Pump Type	Page:
	No Load	Load	No Load	Load	No Load	Load	No Load	Load	No Load	Load	No Load	Load	No Load	Load	No Load	Load		
▼ Power Source Manual	1,4	1,4	0,6	0,6	0,4	0,4	0,3	0,3	0,2	0,2	0,1	0,1	0,1	0,1	0,1	0,1	P141	76
	3,9	3,9	1,7	1,7	1,2	1,2	0,7	0,7	0,6	0,6	0,3	0,3	0,2	0,2	0,2	0,2	P391	76
	17,6	3,9	7,8	1,7	5,5	1,2	3,4	0,7	2,6	0,6	1,6	0,3	1,0	0,2	0,8	0,2	P392	76
	25,3	3,8	11,2	1,7	7,9	1,2	4,9	0,7	3,7	0,6	2,3	0,3	1,5	0,2	1,1	0,2	P77/80/801/84	78
	61,4	3,9	27,1	1,7	19,3	1,2	11,8	0,7	9,0	0,6	5,5	0,3	3,5	0,2	2,8	0,2	P802/842	78
	197	7,4	87,1	3,3	61,8	2,3	37,9	1,4	29,0	1,1	17,7	0,7	11,4	0,4	8,8	0,3	P462/464	78

Millimetres per Second of RC-Series Cylinder Plunger Travel

Cyl. Capacity ▶	5 ton		10 ton		15 ton		25 ton		30 ton		50 ton		75 ton		100 ton		Pump Type	Page:
	No Load	Load	No Load	Load	No Load	Load	No Load	Load	No Load	Load	No Load	Load	No Load	Load	No Load	Load		
▼ Power Source Electric Pumps (speed based on 50 Hz)	51,3	6,4	23,0	2,9	16,4	2,1	10,0	1,3	7,9	1,0	4,7	0,6	3,2	0,4	2,5	0,3	XC Cordless Pump	86
	128,2	13,3	57,5	6,0	41,1	4,3	25,1	2,6	19,8	1,2	11,7	1,2	8,1	0,8	6,3	0,7	ZC3 Cordless Pump	88
	86	8,3	38	3,7	27	2,6	17	1,6	13	1,3	7,7	0,7	5,4	0,5	4,1	0,4	PU Economy	90
	92,3	12,8	41,4	5,7	29,6	4,1	18,1	2,5	14,3	2,0	8,4	1,2	5,8	0,8	4,5	0,6	E-Pulse	94
	295	25,6	132	11,5	94,4	8,2	57,7	5,0	45,5	4,0	26,9	2,3	18,7	1,6	14,4	1,3	ZU4-Series	97-98
	15,1	14,1	6,8	6,3	4,8	4,5	3,0	2,8	2,2	1,4	1,3	1,0	0,9	0,7	0,7	0,7	ZE3 one stage	97, 104
	158	14,1	70,7	6,3	50,5	4,5	30,9	2,8	24,3	2,2	14,4	1,3	10,0	0,9	7,7	0,7	ZE3 two stage	97, 104
	22,3	21,0	10,0	9,4	7,1	6,7	4,4	4,1	3,4	3,2	2,0	1,9	1,4	1,3	1,1	1,0	ZE4 one stage	97, 104
	228	21,0	102	9,4	72,9	6,7	44,6	4,1	35,2	3,2	20,8	1,9	14,4	1,3	11,1	1,0	ZE4 two stage	97, 104
	44,9	42,1	20,1	18,9	14,4	13,5	8,8	8,2	6,9	6,5	4,1	3,8	2,8	2,7	2,2	2,1	ZE5 one stage	97, 104
	298	42,1	133	18,9	95,3	13,5	58,3	8,2	46,0	6,5	27,2	3,8	18,9	2,7	14,5	2,1	ZE5 two stage	97, 104
	76,9	70,0	34,5	31,4	24,6	22,4	15,1	13,7	11,9	10,8	7,0	6,4	4,9	4,4	3,8	3,4	ZE6 one stage	97, 104
	315	70,0	141	31,4	101	22,4	61,7	13,7	48,7	10,8	28,8	6,4	20,0	4,4	15,4	3,4	ZE6 two stage	97, 104
	53,8	53,8	24,1	24,1	17,2	17,2	10,5	10,5	8,3	8,3	4,9	4,9	3,4	3,4	2,6	2,6	SFP421 (11 kW)	344
Air Driven Pumps (at 6,9 bar air pressure)	51,3	6,4	23,0	2,9	16,4	2,1	10,0	1,3	7,9	1,0	4,7	0,6	3,2	0,4	2,5	0,3	XA-Series	114
	25,9	4,2	11,6	1,9	8,2	1,3	5,0	0,8	4,0	0,6	2,3	0,4	1,6	0,3	1,3	0,2	PATG-serie Turbo II Air	112
	17	3,4	7,6	1,5	5,4	1,1	3,3	0,7	2,6	0,5	1,5	0,3	1,1	0,2	0,8	0,2	PA-Series	110
	277	3,8	123	1,7	88	1,2	53	0,7	42	0,6	25	0,3	17	0,2	13,0	0,2	PAM-Series	111
	357	33,6	160	15,1	114	10,8	69,9	6,6	55,1	5,2	32,6	3,1	22,6	2,1	17,4	1,6	ZA-Series	97, 116
Gasoline Engine	295	41	132	18,4	94,4	13,1	57,7	8,0	45,5	6,3	26,9	3,7	18,7	2,6	14,4	2,0	ZG5-Series 4,1 kW	97, 118
	166	41	74,7	18,4	53,4	13,1	32,6	8,0	25,7	6,3	15,2	3,7	10,6	2,6	8,1	2,0	ZG5-Series 4,8 kW	97, 118
	376	85	169	37,9	121	27,1	73,8	16,6	58,2	13,1	34,4	7,7	23,9	5,4	18,4	4,1	ZG6-Series 9,7 kW	97, 118

No Load indicates the plunger speed as the plunger extends towards the load (1st stage).

Load indicates the plunger speed as the load is lifted at a system pressure of 700 bar (2nd stage).

Example: At what speed (V) will the RC256 (25 ton) cylinder move when powered by a ZE3-Series pump?

RC256 Cylinder Effective Area = 33,2 cm²

ZE3-Series pump oil Flow (no load) = 6150 cm³/min

$$\text{Cylinder Plunger Speed (mm/sec)} = \frac{\text{Pump Oil Flow (cm}^3\text{/min)} \times 10}{\text{Cylinder Effective Area (cm}^2\text{)} \times 60}$$

$$\text{Speed V} = \frac{6150 \text{ cm}^3\text{/min} \times 10}{33,2 \times 60} = 30,9 \text{ mm/sec}$$



Ways

The (oil) ports on a valve.

A 3-way valve has 3 ports: pressure (P), tank (T), and cylinder (A).

A 4-way valve has 4 ports: pressure (P), tank (T), advance (A) and retract (B).

Single-Acting cylinders require at least a 3-way valve, and can, under certain instances, be operated with a 4-way valve.

Double-Acting cylinders require a 4-way valve, providing control of the flow to each cylinder port.

Positions

The number of control points a valve can provide. A 2-position valve has the ability to control only the advance or retraction of the cylinder. To be able to control the cylinder with a hold position, the valve requires a 3rd position.

Centre Configuration

The centre position of a valve is the position at which there is no movement required of the hydraulic component, whether a tool or cylinder.

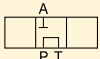

The most common is the **Tandem**

Centre. This configuration provides for little to no movement of the cylinder and the unloading of the pump. This provides for minimum heat build-up.

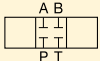

The next most common is the **Closed**

Centre configuration, which is used mostly for independent control of multi-cylinder applications. This configuration again provides for little to no movement of the cylinder, but also dead-heads the pump, isolating it from the circuit.

Use of this type of valve may require some means of unloading the pump to prevent heat build-up.

There are many more type of valves, such as **Open Centre** and **Float Centre**. These valves are used mostly in complex hydraulic circuits and require other special considerations.



Open Centre

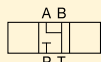

Float Centre

Directional Control Valves

3-Way Valves are used with single-acting cylinders.

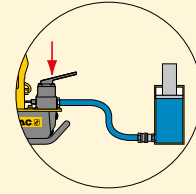

4-Way Valves are used with double-acting cylinders.

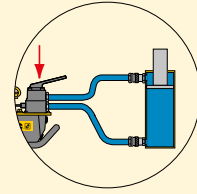

Valves may be either pump mounted or remote mounted.

Pump Mounted

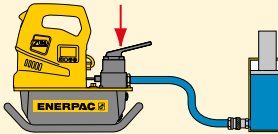

Remote Mounted

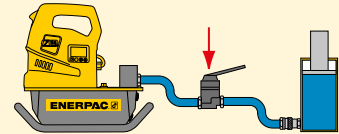

Valves may be either manually or solenoid operated.

Manually Operated

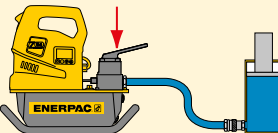

Solenoid Operated

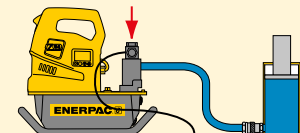

Advance Hold Retract

Single-acting cylinder Controlled by a 3-way, 3-position valve.

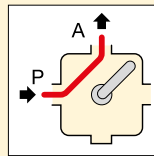

cylinder plunger will extend.

Double-acting cylinder Controlled by a 4-way, 3-position valve.

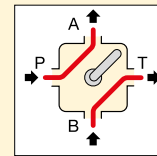

cylinder port B to tank T.

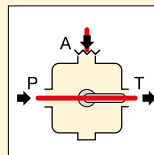

A is closed: the cylinder plunger will maintain its position.

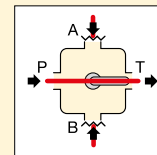

ports A and B are closed: the cylinder plunger will maintain position.

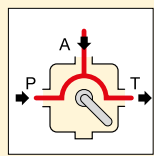

plunger will retract.

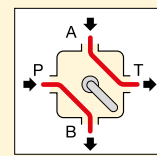

from cylinder port A to tank T: the cylinder plunger will retract.

Hexagon Nut and Bolt Sizes



METRIC SIZES		
Thread Size D (mm)	Hexagon Size S (mm)	Hexagon Size J (mm)
M 10	17	8
M 12	19	10
M 14	22	12
M 16	24	14
M 18	27	14
M 20	30	17
M 22	32	17
M 24	36	19
M 27	41	19
M 30	46	22
M 33	50	24
M 36	55	27
M 39	60	27 (30)
M 42	65	32
M 45	70	-
M 48	75	36
M 52	80	36
M 56	85	41
M 60	90	46
M 64	95	46
M 68	100	50
M 72	105	55
M 76	110	60
M 80	115	65
M 85	120	70
M 90	130	70 (75)
M 95	135	-
M 100	145	85
M 105	150	-
M 110	155	-
M 115	165	-
M 120	170	-
M 125	180	-
M 130	185	-
M 140	200	-
M 150	210	-

IMPERIAL SIZES		
Thread Size D (inch)	Hexagon Size * S (inch)	Hexagon Size J (inch)
5/8"	1 1/16"	1/2"
3/4"	1 1/4"	5/8"
7/8"	1 7/16"	3/4"
1"	1 5/8"	3/4"
1 1/8"	1 13/16"	7/8"
1 1/4"	2"	7/8"
1 3/8"	2 3/16"	1"
1 1/2"	2 3/8"	1"
1 5/8"	2 9/16"	-
1 3/4"	2 3/4"	1 1/4"
1 7/8"	2 15/16"	1 3/8"
2"	3 1/8"	1 5/8"
2 1/4"	3 1/2"	1 3/4"
2 1/2"	3 7/8"	1 7/8"
2 3/4"	4 1/4"	2"
3"	4 5/8"	2 1/4"
3 1/4"	5"	2 1/4"

* Heavy hexagon nuts.



Determine the maximum torque according to the bolt (nut) size and grade. Always consult the manufacturers instructions or engineering recommendations when making bolted connections.



IMPORTANT

The hexagon sizes shown in the tables should be used as a guide only. Individual sizes should be checked before specifying any equipment.



BSH-Series Heavy Duty Sockets

Use only Heavy Duty Impact Sockets for power driven torquing equipment, according to ISO2725 and ISO1174; DIN3129 and

DIN3121 or ASME-B107.2/1995.



Tightening Methods

Principally there are two modes of tightening: "Uncontrolled" and "Controlled".

Uncontrolled tightening

Uses equipment and/or procedures that cannot be measured. Preload is applied to a bolt and nut assembly using a hammer and spanner or other types of impact tools.

Controlled tightening

Employs calibrated and measurable equipment, follows prescribed procedures and is carried out by trained personnel.

Advantages of Controlled Tightening

Known, controllable and accurate bolt loads

Employs tooling with controllable outputs and adopts calculation to determine the required tool settings.

Uniformity of bolt loading

Especially important on gasketed joints as an even and consistent compression is required for the gasket to be effective.

Safe operation following prescribed procedures

Eliminates the dangerous activities of manual uncontrolled tightening and requires that the operators be skilled and follow procedures.

Reduces operational time resulting in increased productivity

Reduces tightening time and operator fatigue by replacing manual effort with the use of controlled tooling.

Reliable and repeatable results

Using calibrated, tested equipment, following procedures and employing skilled operators achieves known results consistently.

The right results first time

Many of the uncertainties surrounding in-service joint failures are removed by ensuring the correct assembly and tightening of the joint the first time.



Bolting Tools

For further information on Torque Tightening or other controlled tightening methods, please visit our website or ask for our **Bolting Tools Catalogue**.

Bolting Integrity Software

A comprehensive free on-line software solution for Bolted Joint Integrity.

Integral databases hold data for:

- ASME B16.5, ASME B16.47, API 6A and API 17D flanged joints
- Common gasket materials and configurations
- Comprehensive range of bolt materials
- Comprehensive range of lubricants
- Enerpac's Controlled Bolting Equipment including: Torque Multipliers, Hydraulic Wrenches and Bolt Tensioning tools.

Custom Joint information can also be entered.

The software offers Tool selection, Bolt Load calculations and Tool pressure settings, as well as a combined Application data sheet and Joint completion report.

What is Torque?

It is a measure of how much force acting on an object causes that object to rotate.

What is Torque Tightening?

The application of preload to a fastener by the turning of the fastener's nut.

Torque Tightening and Preload

The amount of preload created when torqueing is largely dependant on the effects of friction.

Principally there are three different "torque components":

- torque to stretch the bolt
- torque to overcome the friction in bolt and nut threads
- torque to overcome friction at the nut spot face (bearing contact surface).

Torque Tightening

Turning movement

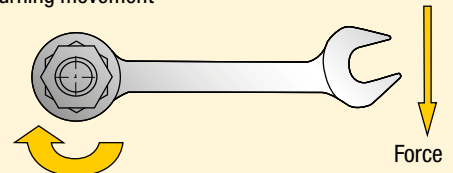

Stretch of Fastener (Pre-load)

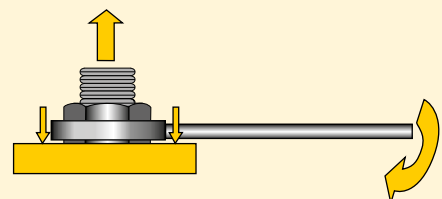



Preload (residual load) = Applied Torque *minus* Frictional Losses

Lubrication Reduces Friction

Lubrication reduces the friction during tightening, decreases bolt failure during installation and increases bolt service life. Variation in friction coefficients affect the amount of preload achieved at a specified torque. Higher friction results in less conversion of torque to preload. The value for the friction coefficient provided by the lubricant manufacturer must be known to accurately establish the required torque value.

Lubricant or anti-seizure compounds should be applied to both, the nut bearing surface and the male threads.

Frictional Losses

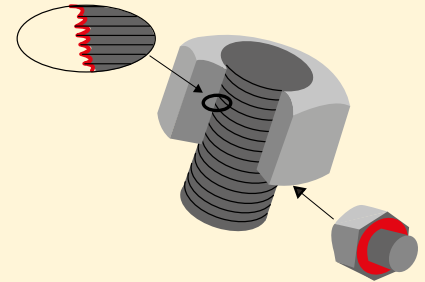
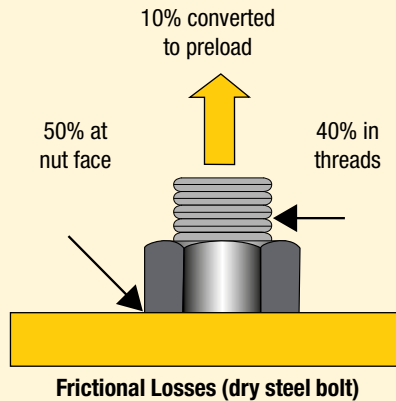

Friction points should always be lubricated when using the torque tightening method.



Select the Right Torque Wrench

Choose your Enerpac torque wrench using the untightening rule of thumb:

- When loosening a nut or bolt, more torque is usually required than when tightening.
- For general conditions it can take up to **2½ times** the input torque to breakout.
- Do not apply more than 75% of the maximum torque output of the tool when loosening nuts or bolts.

Conditions of bolted joints

- Humidity corrosion (rust) requires up to **twice** the torque required for tightening.
- Sea water and chemical corrosion requires up to **2½ times** the torque required for tightening.
- Heat corrosion requires up to **3 times** the torque required for tightening.

Torque Procedure

When torquing it is common to tighten only one bolt at a time, which can result in Point Loading and Load Scatter.

To avoid this, torque is applied in stages following a prescribed pattern:

Torque Sequence

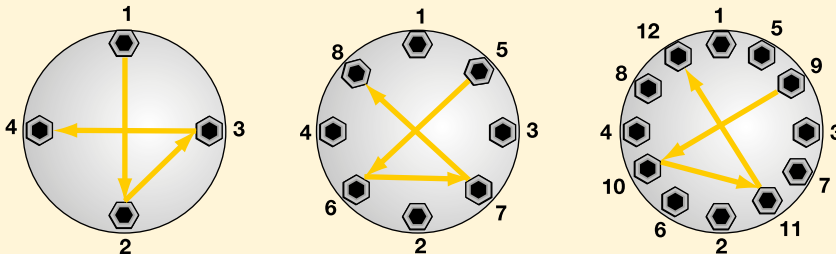

- Step 1** Spanner tight ensuring that 2 - 3 threads extend above nut.
- Step 2** Tighten each bolt to one-third of the final required torque following the pattern as shown above.
- Step 3** Increase the torque to two-thirds following the pattern shown above.

- Step 4** Increase the torque to full torque following the pattern shown above.
- Step 5** Perform one final pass on each bolt working clockwise from bolt 1, at the full final torque.



Breakout Torque

When loosening bolts a torque value higher than the tightening torque is normally required. This is mainly due to corrosion and deformations in the bolt and nut threads.

Breakout torque cannot be accurately calculated, however, depending on conditions it can take up to **2½ times** the input torque to breakout.

The use of penetrating oils or anti-seize products is always recommended when performing breakout operations.



Tensioning requires longer bolts



INCORRECT

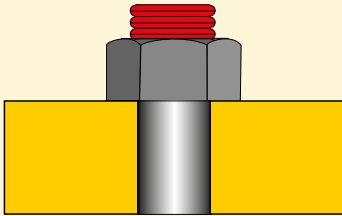

CORRECT

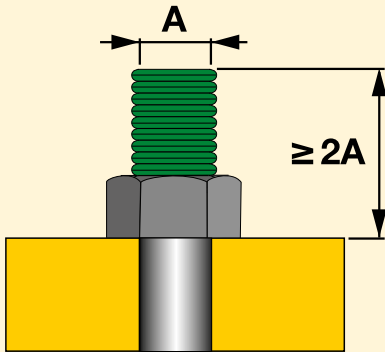

What is Bolt Tensioning?

Tensioning is the direct axial stretching of the bolt to achieve preload. Inaccuracies created through friction are eliminated. Massive mechanical effort to create torque is replaced with simple hydraulic pressure. A uniform load can be applied by tensioning multiple studs simultaneously.

Tensioning requires longer bolts, and a seating area on the assembly around the nut. Tensioning can be done using detachable Bolt Tensioners or Hydraulic Nuts.



Preload (residual load) = Applied Load minus Load Losses

What is Load Loss?

Load loss is a loss of bolt elongation depending on factors such as thread deflections, radial expansion of the nut, and embedding of the nut into the contact area of the joint. Load loss is accounted for in calculation and is added to the preload value to determine the initial **Applied Load**.

The preload depends on Applied Load and Load Loss (load loss factor).



GLOSSARY OF TERMS

Applied Load:

The load applied to a bolt during tensioning which includes an allowance for Load Loss.

Bolt Tensioning:

A method of controlled tightening which applies preload to a bolt by stretching it axially.

Breakout Torque:

The amount of torque required to loosen a tightened bolt. (Usually more torque is required to loosen a bolt than was used to tighten it.)

Elastic Range:

The range on a bolt's stress / strain curve where stress is directionally proportional to strain.

Plastic Range:

The range on a stress / strain curve where the tensile load applied to a bolt results in permanent deformation.

Load Loss:

The losses in a bolt which occur on transfer of load from a tensioning device to the bolt assembly (these may arise from phenomena such as thread deflection and embedding of the nut to the contact area of the joint, and is calculated as a factor of the length to diameter ratio of the bolt).

Load Scatter:

The spread of differing loads in a sequence of bolts after they have been loaded. It is mostly due to the elastic interaction of the bolts and the joint member; as subsequently tightened bolts further compress the joint, previously tightened bolts are subject to some relaxation.

Preload:

The load in a bolt immediately after it has been tightened.

Proof Load:

Proof load is often used interchangeably with Yield Strength but is usually measured at 0,2% plastic strain.

Tensile Point:

The point at which the tensile loading on a bolt causes the bolt to rupture.

Torque Tightening:

The application of Preload to a bolt by turning of the bolt's nut.

Ultimate Strength:

The maximum tension which can be created by tensile load on a bolt.

Yield Strength:

The point at which a bolt begins to plastically deform under tensile loading.

NOTE: Bolt is used as a generic term for a threaded fastener.



80% **Manufacturer's rating of pressure and load are maximum safe limits. Good practice encourages using only 80% of these ratings!** **80%**

Tensioning Operation

Tensioning permits the simultaneous tightening of multiple bolts; the tools are connected in sequence via a high-pressure hose assembly to a single pump unit. This ensures each tool develops the exact same load and

provides a uniform clamping force across the joint. This is especially important for pressure containing vessels requiring even gasket compression to affect a seal.

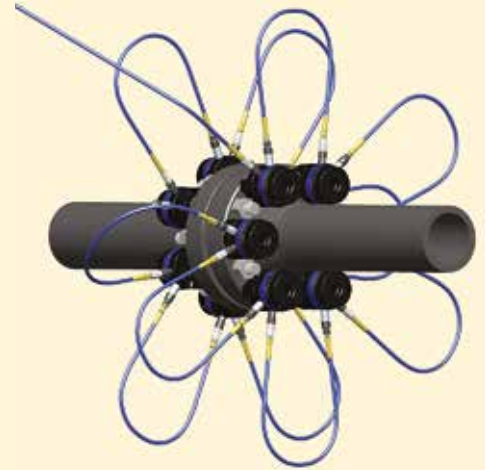

Set-up using a 100% tensioning procedure

All bolts are tensioned simultaneously.

General Procedure

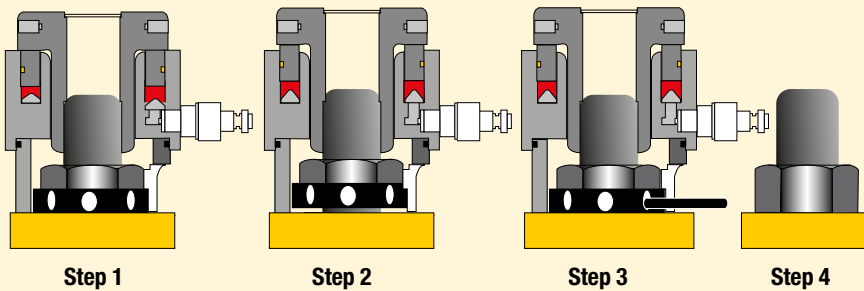

- Step 1:** The bolt tensioner is fitted over the stud.
- Step 2:** Hydraulic pressure is applied to the tensioner which then stretches the stud (bolt).
- Step 3:** The stud's nut is wound down against the joint face

- Step 4:** Hydraulic pressure is released and the tensioner removed. The bolt behaves like a spring, when the hydraulic pressure is released the bolt is under tension and attempts to contract, creating the required clamping force across the joint.

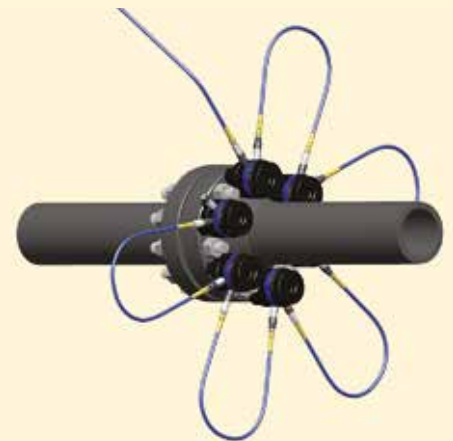

Set-up using a 50% tensioning procedure

Half the bolts are tensioned simultaneously, the tools are relocated on the remaining bolts and they are subsequently tensioned.

Less than 100% Tensioning

Not all applications allow for the simultaneous fit of a tensioning device on each bolt, in these cases at least two tensioning pressures are applied. This is to account for a load loss in those bolts already tensioned as the next sets are tightened.

The load losses are accounted for in calculation and a higher load is applied to allow the first sets to relax back to the target preload.



Read Instruction Manuals

Please refer to the product Instruction Sheets for safe use guidelines and detail on the correct set up and operation of the equipment.



Enerpac Bolting Integrity Software Solutions play a key role in implementing and managing an Integrity Programme for bolted connections. The software is used extensively within Enerpac and increasingly by a wide range of clients worldwide often interfacing with maintenance, construction and commissioning management systems.

- First developed over 20 years ago, we have continued to update and enhance the software based on user feedback, technology advances and our roles on Industry standard committees, to produce the most comprehensive suite of joint integrity software available.
- Recommended bolt loads for standard joints are derived from independently verified calculation methods and traceable back to standards

Integral databases hold data for:

- ASME B16.5, ASME B16.47, API 6A and API 17D flanged joints
- Common gasket materials and configurations
- Comprehensive flange and bolt materials
- Comprehensive range of lubricants
- Enerpac controlled bolting equipment includes torque, multipliers, hydraulic wrenches and bolt tensioners.
- Custom joint information can also be entered.



▲ Standard flange calculation menu (INFORMATE)

The Enerpac Bolting Software Suite includes:

- **Bolt-Up** - Online bolt load calculator. Free access and use on www.enerpac.com.
- **INFORMATE** - Advanced calculation and procedure software. Contact Enerpac for user licenses and dedicated support.
- **IDMS Integrity Data Management System** - A complete Integrity Assurance project management package for managing bolted joints from cradle to grave. Contact Enerpac for user licenses and dedicated support.

Bolt-Up

Bolt-Up is a simple to use online calculator, built upon the Informate calculation engine, providing reliable, repeatable bolt loads for:

- Carbon steel weldneck ANSI 16.5 standard flanges, using a limited range of bolt materials; selected gasket options and a fixed lubrication value.
- Inputting basic joint configuration information allows Bolt-Up to determine: bolt load; bolt stress and the required torque. These outputs are displayed alongside basic flange and bolt information e.g. joint thickness and bolt size/quantity.



Bolting Integrity Software

The software offers Tool selection, Bolt Load calculations and Tool pressure settings, as well as, a combined Application data sheet and Joint completion report.

This software includes following hydraulic tools selections:

- S, W, RSL, DSX and HMT-Series Torque Wrenches,
- HM-Series HydraMax®, GT-Series Bolt Tensioners and EAJ-Series AquaJack Subsea Tensioners.

Software Model Nr.	INFORMATE Subscriptions
BS01PP	Bolting Software 1 person purchase
BS01PAS	Bolting Software 1 person annual support
BS05PP	Bolting Software 5 person purchase
BS05PAS	Bolting Software 5 person annual support

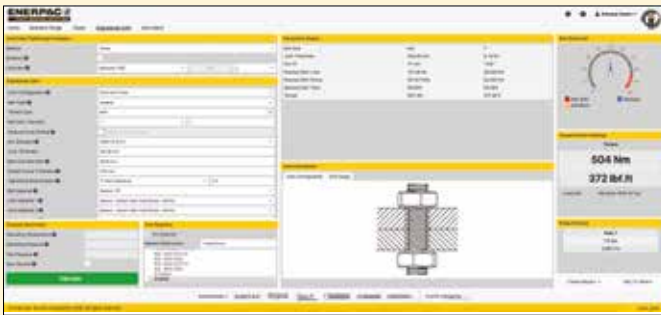

▲ Enginered Joint menu (INFORMATE)

INFORMATE Bolt Load Calculation Software

INFORMATE can be used on a huge range of flanged joints and clamped connections in virtually any situation from process piping to custom-designed flange connections.

- Calculate bolt loads and stresses, determine tooling pressures for Enerpac torque and tensioning equipment; analyse existing connections and test custom designed connections.
- Extensive material database covering all common standards:
 - Common and industry specific lubricants
 - 200+ bolting materials
 - 500+ flange materials
 - 60+ gasket materials
- Enginered Joint Calculation Features - allows for different types of bolted application for non-circular or structural applications.
- Installed direct to the desktop or accessed via the internet, Informate is available in a single version that is configurable to client requirements and includes multiple international standards and the latest and forthcoming regulatory data, when taken with a maintenance package.



▲ Clamp menu (INFORMATE)

Integrity Data Management System (iDMS)

iDMS is a flexible data management and activity planning system specifically for use on assets featuring bolted connections.

Designed to store the entire lifecycle data relating to every critical bolted joint on an installation, it aids planning, ensures joint integrity, as well as reducing construction and maintenance schedules and costs.

- Provides managers and technicians with essential information about joint components used in assembly, in addition it specifies the tools and the torque or tension values to deliver a leak-free joint.
- Allows planner and maintenance engineers to rapidly build packages of work complete with all documentation and then track them to completion
- Whenever a joint is worked on, all of the previous history and experience of that joint is available, allowing any particular requirements of the joint to be taken into account proactively prior to joint assembly and tightening.

iDMS Custom Tailored Solutions available to meet client needs, for example:

- Embedded Informate bolted joint calculator
- Export and import of data to asset management systems
- Exporting data to populate customer documentation
- Colour coding of the joint provides an instant review of the status.

Contact Enerpac for User License



The Enerpac Academy is our in-house training program, offering Enerpac product operators and maintenance staff the opportunity to be trained in the safe use and maintenance of high-pressure hydraulic tools.

Operating these tools requires sound knowledge of how they work and how they should be maintained. Correct use of these tools increases safety and reduces risk – both for the operator and the environment in which the tools are used. Having the right training enables the operator to use the tools safely and properly.

- Safety focus for operators, tools and environment
- Dedicated in-house Enerpac training centers
- Both standard training courses and specialized training services
- Highly experienced training staff
- Develops alternative training options such as:
 - eLearning modules
 - vLearning sessions
 - Instructional videos

In-house Training Centres



Do you work with high-pressure hydraulic tools on a regular basis or even every day? The training courses are designed to be highly interactive with a strong hands-on element. Each training course is led by a qualified trainer, an Enerpac specialist capable of providing high quality training. A written or practical exam is part of certain training courses.

Training Centre Locations



Enerpac Academy offers a meticulously compiled training program covering tool knowledge, repairs and maintenance, and safe operation of Enerpac hydraulic tools. If you would like to schedule a training course, please contact Enerpac for a training calendar, application form, and brochure at www.enerpac.com.

- Ede (The Netherlands), • Bangalore (India)
- Columbus, Wisconsin (USA), • Singapore
- Perth (Australia).

In-Person Training



- Highly experienced training staff
- Class sizes range from 8 to 20, depending on class and location
- Commercial Sales, Service and Repair Class capabilities
- Most classes consist of theoretical and hands-on training.

Instructional Videos



- Informational videos created with Enerpac Academy Training processes in-mind
- Topics range from product “how-to” videos to application and operational videos
- Videos are available on the Enerpac “You-Tube” channel and other venues, where appropriate.

eLearning Modules



- Enerpac Training available on “your” schedule
- Courses available to support New Product Launches, Product Awareness Training and Enerpac Academy Courses
- Available to external viewers through Enerpac’s “LDMS” system.



EMP – Enerpac Maintenance Program

EMP is a preventive maintenance program. Your Enerpac Authorized Service Centre will check the tools on essential points: leaking, oil level and quality, maximum pressure setting, and damage. EMP reduces operational risks, increases safety and minimises extremely expensive delays in your operations.

You will be advised about regular maintenance of the Enerpac tools.

- Work more safely
- Minimise operational risk
- Ensure tools are always available and in tip-top shape
- As good as new after repair
- Prevent downtime
- Advice on safe and effective use
- Maintenance when tools are not used.

vLearning sessions

- Interactive training available on-line
- Sessions contain Technical Presentations, Hands-on product demos and end with a Q&A session
- Classes cover many topics, such as Product Operational information and Service & Repair Training
- Look for scheduling and registration details on www.enerpac.com

Model Number Index

Page(s) ▼	Page(s) ▼	Page(s) ▼	Page(s) ▼	Page(s) ▼
A	E	I	R	T
A5-A10 182	E 264-265	IDMS 422-423	RA 11-21	T 130-131, 140, 399
A12 10	EAJ 300-301	INFORMATE 422-423	RAC 12-13	TES 365
A13-A28 182	EBC 205	IPA 148-151	RACH 16-17	TFA 340
A29-A53 10	EBE 204	IPE 148-151	RACL 14-15	TH 131
A64-A66 132	EBH 203	IPH 148-151	RAR 20-21	THQ 239-292
A92 182, 195	ECCE 208-209	IPL 150	RARH 18-19	TM 157
A102 10, 41	ECSE 213	IPM 165	RAT 269	TQ 273, 278-279
A128 182	ED 269	IPR 152-153	RB 10	TR 131
A130-A136, A175 151	EDCH 206		RC 6-9, 62-65	TSP 220, 228
A183 154	EFBE 207		RCH 34-35, 62	TWM 249
A185 154, 182	ELP 192-193		RCS 26-27, 62, 65	
A192 182	EMP 424	J	RE 10	V
A200R 150, 152	EP 94-95, 273, 276-277	JBA 13	RFL 110-112, 115	V 64, 143-145
A205 154-155	ER 192-193	JBI 10	RLP 242-251	VA2 111
A218 182	ERA 249, 269	JH, JHA 66	RLT 28-28	VB 154
A220 154-155	ERT 249	JS 358-359	RP 198-199	VC3, VC4 124-125
A252 10, 41	ES 192-192		RR 40-43	VC10 326, 336-337
A305 182	ETR 374-375	L	RRH 36-37	VC15, 20 124-125
A310, A330 154-155	ETT 376	LAT 273, 286-287	RSM 26-27, 65	VE 122-123
A530-A595 182	EVO, EVOP 348-351	LGH 185-169, 171	RSL 242-253, 273	VLP 154-155
A604 130-131	EWC 210-212	LGM 166-167	RSQ 242-243, 252-253	VM 122-123, 125
A607, A650 182		LH 157, 368-371	RT 30-31	VMC 123, 125
A630, AH 130-131		LMR 392	RTE 223	VU 123
AM 132	F	LPH 392	RWH 160-162	
AMGC 29, 132	F 130-131	LPL 24-25, 45		W
AR 130-131	F01 389	LSA 395		W 228-240, 273
ATM 314-315	FC 331	LW 65, 188	S	WCB 214-215
ATP 311	FF 324-325, 386		S 220-223, 273	WHC 214
AW 10	FH 130-131	M	SB 188, 317	WHR 214
	FR 130-131	MCS 272	SBJS 359	WMC 215
B	FRL 266-267	MDWS 396	SBL 366-367	WP 391
B 205, 309	FSB 316-317	MG 326, 338	SBLT 359	WR 183, 195
BAD 39	FSC 316-317, 320	MHT 394	SBZ 103, 108, 282	WRP 240
BC 205	FSH, FSM 316-317	MITT 402-403	SC 62-63, 65	WTE 240
BFZ 133	FTE 306-307	ML 364-365	SCC 360	
BH 309	FTR 304-305	MLS 190-191	SCH 63	X
BHP 160-163, 170	FZ 133	MM 386-387	SCJ 352-355	XA 63, 114-115
Bolt-Up 422		MP 82	SCL 63, 65	XC 167, 169, 171, 176
BLS 356-357	G	MPS 175	SCR 63, 65	XC 63, 86-87, 167, 169
BLJS 359	G 136-137	MR 392	SD 361 171, 176, 273-275
BLT 269	GA 142-143	MS 180-183	SDA 222	XLK 114
BR 309	GBJ 67	MSP 185	SFM 134-135	XL PSS 149
BRC 32-33	GeniSYS 400-401	MST 312	SFP 344-347, 369	XSC 114, 133
BRD 38-39	GF 136-137	MTTP 377	SG 326, 332-335	
BRP 32-33	GKHC 203, 206	MZ 182-183	SGH 172-173	Z
BS 397	GMRF 393	 175-177	Z 131
BSA 137, 139	GP 136-137	N	SGM 172-1742	ZA4 97, 116-117
BSH 224	GPS 176-177	NC 318-319	SHS 362-363	ZA4T 97, 273, 288-293
BSO 422	GST 364	NCB 319	SHAS 362-363	ZC 88-89, 198-199, 217
BUS 225	GT 278, 281, 298-299	NSC 320-321	SL 366-367	ZCF 102, 108
BW 309		NSH 320-323	SLLP 361	ZE2 92-93, 97
BZ 196-197	H	NSP 322-323	SLRA 269	ZE3-ZE6 97, 104-109
	H 128-129, 138-139	NV 143	SLS 65 216-217
C	HA, HB 128-129	O	SLW 65	ZE4T, ZE5T 273, 284-285
C 130-131	HBH 364	OM 390	SOH 189	ZG 97, 118-119
CATS 10, 13, 15, 21	HC 128-129		SP 184-187	ZHE 102, 109
..... 27, 41, 49-59	HCG 44-51	P	SPD 185	ZLS 103, 108
CD-CH 130-131	HCL 44-47, 56-59	P 64, 76-81, 83-85	SPK 184	ZPF 103, 108
CH720 216-217	HCR 44-47, 52-55 169, 171, 176	SPMT 377	ZPS 109
CHM 7	HCRL 42-46, 60-61	P142AL, P392AL 64	SR 361	ZPT 102, 109
CHT 395	HF 132	P392FP 63, 83	SRA 269	ZRB 102, 108
CLNC 348, 351	HLP 258-261	PA 110	SRS 65, 223	ZRC 102, 108
CM 194	HM 294-297	PAM 111	STB 196-197	ZU4 97-103, 196
CR, CT 130-131	HMT 258-263, 273	PAMG 112-113	STC 214	ZU4T 97, 273, 280-283
CU 22-23	HN 313	PARG 112-113	STF 317	ZUTP 302
CW 182	HP 19, 35, 37, 341	PATG 112-113, 185, 196	STN 318	
	HPT 308	PC 76, 78	STP 185	11
D	HRP 260	PF25 103, 108	STTC 270-271	11 - 45 84-85, 140
DDA 256	HSK 372-373	PGT 302-303	STTL 226-227	67 335, 337
DDU 399	HSL 360-361	PL 70-71	SWH 220, 228, 238	72 - 83 84, 140
DLR 388-389	HSQ 259, 262-263	PR 68-69 254, 262	1440 341
DGR 141	HT 309, 398	PTW 266-269	SWI 326, 328-331	3027 341
DSA 269	HTE 260	PU 90-91, 167, 169,	SWR 65	
DSX 254-256, 273	HTM 394 171, 176		

**Cylinders &
Lifting Products**



**Pumps &
Directional
Valves**



**System
Components &
Control Valves**



Presses



Pullers



Specialty Tools



Cutters



Bolting Tools



**Flange
Maintenance
Tools**



**Heavy Lifting
Technology**



**On-site
Machining
Tools**



EXTENSIVE GLOBAL DISTRIBUTION NETWORK

WHERE TO BUY THE RIGHT TOOLS

With over 1500+ distributors and 3500+ points of sale in over 100+ countries, Enerpac has a vast distribution network to reach all your local industrial tool needs. Find on-demand access to application experts who can provide hands-on demonstrations, help with product selection or discuss rental options along with on-going service.



WORLD CLASS SUPPORT

RESULTS IN THE RIGHT TOOL

Whether you're looking for help identifying the right product, receive technical support, training or request product materials, we have experts ready to answer your questions and provide guidance on the tool or accessory that will help get your toughest job done. Reach out to us at Enerpac.com/support.



GET THE LATEST VERSION