

For Low Pressure

# MINI CUPLA

Standard type for use on equipment for welding and gas cutting, etc.

Working pressure: **0.7** MPa (7 kgf/cm<sup>2</sup>)

Valve structure: One-way shut-off

Applicable fluids: Oxygen, Fuel Gas

## Exclusively for oxyacetylene equipment. Many variations with higher flow rates!

- From cylinders to torches, all piping connections associated with welding and cutting equipment are push-to-connect operations.
- Double-lip seal prevents minor leak during connection. Oxygen and fuel gas CUPLA have different sizes to prevent accidental interconnection.
- Pressure loss is minimized to achieve higher flow rate.
- Various types of end configurations have been standardized to comply with a wide range of welding and cutting equipment applications. Sockets themselves or plugs themselves are interchangeable with MINI CUPLA SUPER's counterparts.
- LINE CUPLA MINI is also available for multiple piping.

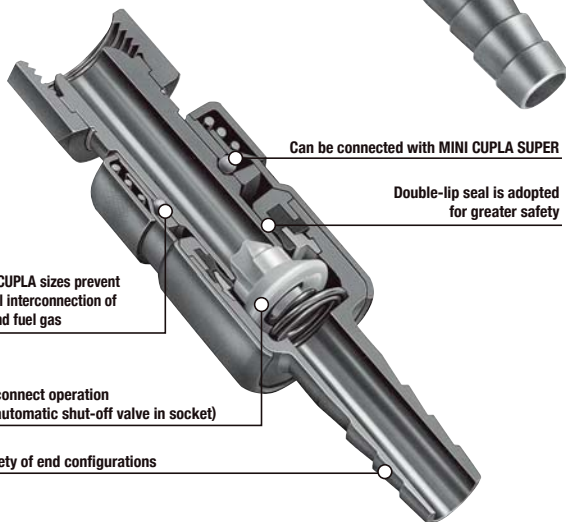

### Structure and Principle of Backflow Prevention

#### Plug with backflow stop valve (22PHB, 25PHB, 22PFB, 33PHB, 35PHB, 33PFB)

Plugs with backflow stop valve in MINI CUPLA are designed exclusively for gas welding/cutting to prevent occurrence of gas mixing. Possible backflow of gas during operation can be stopped by cutting the back flow into the cylinder or line. Such valve is adopted in both fuel gas and oxygen plug.

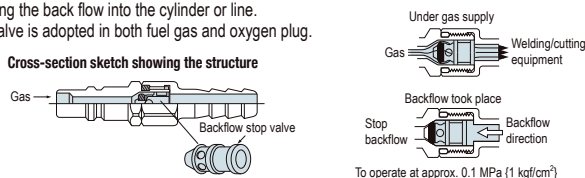

### Specifications

Body material		Brass			
Size	Thread	1/8", 1/4", 3/8" / M16, W12.5-20			
	Hose barb	1/4", 5/16", 3/8"			
Pressure unit	MPa	kgf/cm <sup>2</sup>	bar	PSI	
Working pressure	0.7	7	7	102	
Seal material	Seal material	Mark	Working temperature range	Remarks	
Working temperature range*1	Nitrile rubber	NBR	-20 °C to +80 °C	Standard material	

\*1: The operable temperature range depends on the operating conditions.

### Maximum Tightening Torque

Model	22PF, 22PFB, 22SF, 25PF, 33PF, 33PFB, 33SF	22SM	33SM
Torque	12 {122}	9 {92}	11 {112}

### Flow Direction



### Interchangeability

To prevent accidental connection, CUPLA for oxygen are not interchangeable with CUPLA for fuel gas. However, plugs and sockets for oxygen are interchangeable regardless of end configurations and plugs and sockets for fuel gas are interchangeable regardless of end configurations.

\*Interchangeable with MINI CUPLA SUPER.

### Minimum Cross-Sectional Area

		(mm <sup>2</sup> )									
For Oxygen		22PH	25PH	22PF	22PFF	25PF	22PHB	25PHB	22PFB	21PMT	22PMT
Socket	Plug										
22SH		19.6	19.6	19.6	19.6	19.6	15.9	15.9	15.9	19.6	19.6
25SH		19.6	19.6	19.6	19.6	19.6	15.9	15.9	15.9	19.6	19.6
22SF		19.6	19.6	19.6	19.6	19.6	15.9	15.9	15.9	19.6	19.6
22SM		19.6	19.6	19.6	19.6	19.6	15.9	15.9	15.9	19.6	19.6

### For Fuel Gas

		33PH	35PH	33PF	33PHB	35PHB	33PFB
Socket	Plug						
33SH		44.1	28.2	44.1	15.9	15.9	15.9
35SH		28.2	28.2	28.2	15.9	15.9	15.9
33SF		19.6	19.6	19.6	15.9	15.9	15.9
33SM		44.1	28.2	44.1	15.9	15.9	15.9

### Suitability for Vacuum

Not suitable for vacuum application in either connected or disconnected condition.

### Pressure - Flow Characteristics

[Test conditions] - Fluid : Air

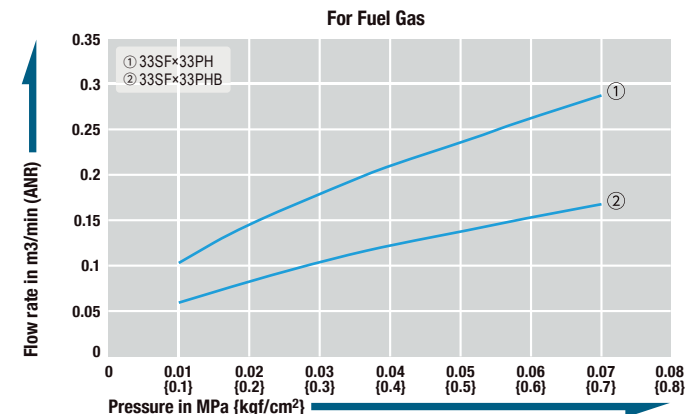
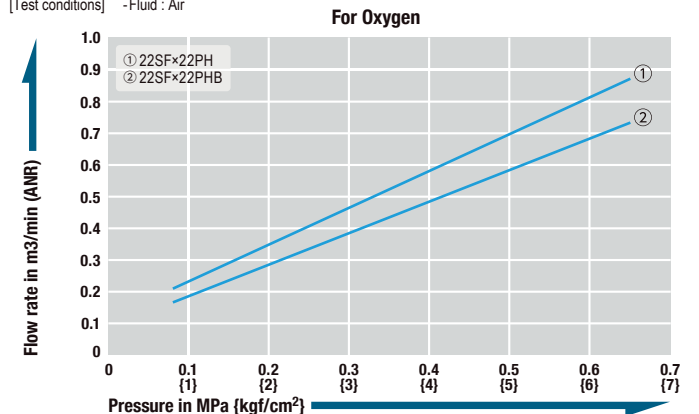

Models and Dimensions

**Plug PH type (Hose barb)**

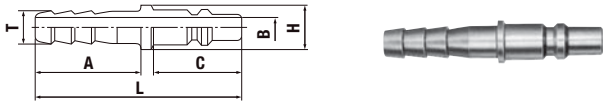

Usage	Model	Application (Hose)	Mass (g)	Dimensions (mm)					
				L	C	A	øH	øT	øB
For Oxygen	22PH	1/4"	16	55	23.5	28	11	7.8	5
	25PH	5/16"	19					9	
For Fuel Gas	33PH	3/8"	22	57	25.5	28	14	10.5	7.5
	35PH	5/16"	20					9	

**Socket SH type (Hose barb)**

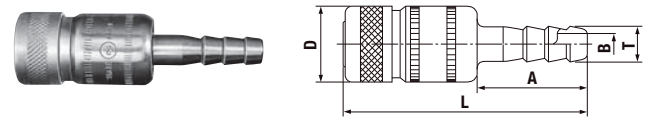

Usage	Model	Application (Hose)	Mass (g)	Dimensions (mm)					
				L	øD	A	øT	øB	
For Oxygen	22SH	1/4"	52	(65)	(19.8)	29	7.8	5	
	25SH	5/16"	55						9
For Fuel Gas	33SH	3/8"	69	(66)	(22.6)	29	10.5	7.5	
	35SH	5/16"	67				9		6

**Plug PF type (Female thread for torch connection)**

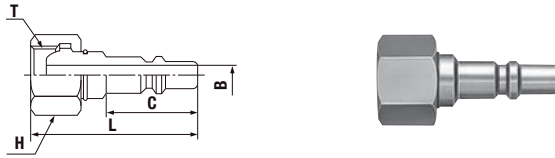

Usage	Model	Application (Thread)	Mass (g)	Dimensions (mm)					
				L	C	H(WAF)	T	øB	
For Oxygen	22PF	For oxygen torch side	31	(43)	23.5	Hex.19	M16×1.5	5	
	22PFF		29	(43.5)					G 1/4
	25PF		26						W12.5-20
For Fuel Gas	33PF	For fuel gas torch side	36	(44.5)	25.5	Hex.19	M16×1.5 left-hand thread	7.5	

**Socket SF type (Female thread for cylinder connection)**

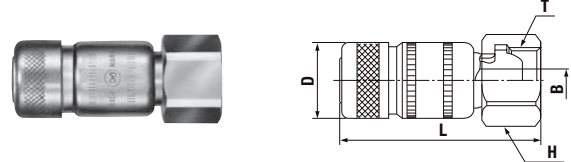

Usage	Model	Application (Thread)	Mass (g)	Dimensions (mm)					
				L	øD	T	øB	H(WAF)	
For Oxygen	22SF	For oxygen gauge side	80	(52)	(19.8)	M16×1.5	5	Hex.19	
For Fuel Gas	33SF	For fuel gas gauge side	96	(54)	(22.6)	M16×1.5 left-hand thread	5	Hex.19	

**Plug PHB type (Hose barb with backflow stop valve)**

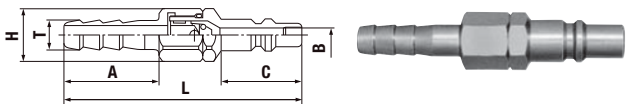

Usage	Model	Application (Hose)	Mass (g)	Dimensions (mm)					
				L	C	A	øH	øT	øB
For Oxygen	22PHB	1/4"	31	(69.6)	23.5	28	15.5	7.8	4.5
	25PHB	5/16"	34					9	
For Fuel Gas	33PHB	3/8"	41	(70.6)	25.5	28	15.5	10.5	4.5
	35PHB	5/16"	39					9	

**Socket SM type (Male thread)**

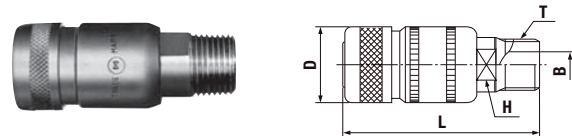

Usage	Model	Application (Thread)	Mass (g)	Dimensions (mm)					
				L	øD	H(WAF)	T	øB	
For Oxygen	22SM	Rc 1/4	51	(52)	(19.8)	12	R 1/4	7.5	
For Fuel Gas	33SM	Rc 3/8	77	(55)	(22.6)	14	R 3/8	10	

**Plug PFB type (Female thread with backflow stop valve for torch connection)**

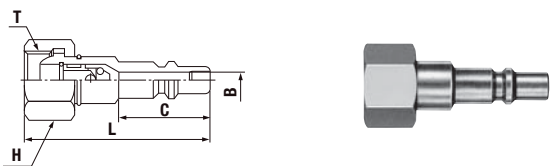

Usage	Model	Application (Thread)	Mass (g)	Dimensions (mm)					
				L	C	H(WAF)	T	øB	
For Oxygen	22PFB	For oxygen torch side	36	(48.5)	23.5	Hex.19	M16×1.5	4.5	
For Fuel Gas	33PFB	For fuel gas torch side	41	(49)	25.5	Hex.19	M16×1.5 left-hand thread	4.5	

**Plug PMT type (Male thread)**

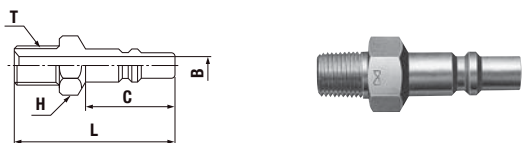

Usage	Model	Application (Thread)	Mass (g)	Dimensions (mm)					
				L	C	H(WAF)	T	øB	
For Oxygen	21PMT	Rc 1/8	22	43.5	24	Hex.14	R 1/8	5	
	22PMT	Rc 1/4	27	45	24	Hex.14	R 1/4	5	

**Socket LINE CUPLA MINI LM-32 (For three port branch piping)**

Mass : 4,300 g  
 • Dust caps come with the product as standard.

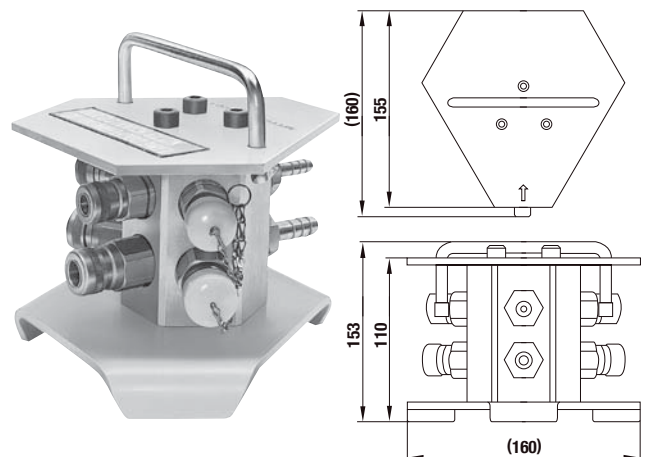

LINE CUPLA MINI contains:				Dimensions (mm)		
	For Oxygen	For Fuel Gas	Qty			
Supply port	1/4"	3/8"	Each 1 pc.			
Gas outlets	22SM	33SM	Each 3 pc.			
Accessories (Plug with backflow stop valve)	22PHB	33PHB	Each 3 pc.			