

For Multi-Port Connection (Automatic)

Multi Cupla

MALC-SP Type for Medium Pressure Use

Low spill type for medium pressure use

Working pressure



1.5 to 7.0 MPa
(15 to 71 kgf/cm²)

Valve structure



Two-way shut-off
(Non-Spill)

Applicable fluids



Water

Hydraulic oil

Air

A single operation enables simultaneous connections of multiple lines. A special design for medium pressure use minimizes air admixture in fluid lines upon connection.

- Compared with conventional Multi Cuplas, approximately double flow rates are realized. This could reduce the size of required plates. (Rate of flow increase depends on Cupla sizes.)
- The MALC type realizes a 2 mm axial eccentricity allowance, while the conventional Multi Cupla is only 0.6 mm.
- Special valve design enables connection of socket and plug under pressure of up to 2 MPa. (up to 1.5 MPa for MALC-12SP.)
- When connected, the distance between the socket plate and the plug plate is designed to be 30 mm for all sizes. This means that any size of Cupla can be mounted and used on the same plate.
- Low spill valves minimize outflow of fluid and admixture of air into the fluid line.

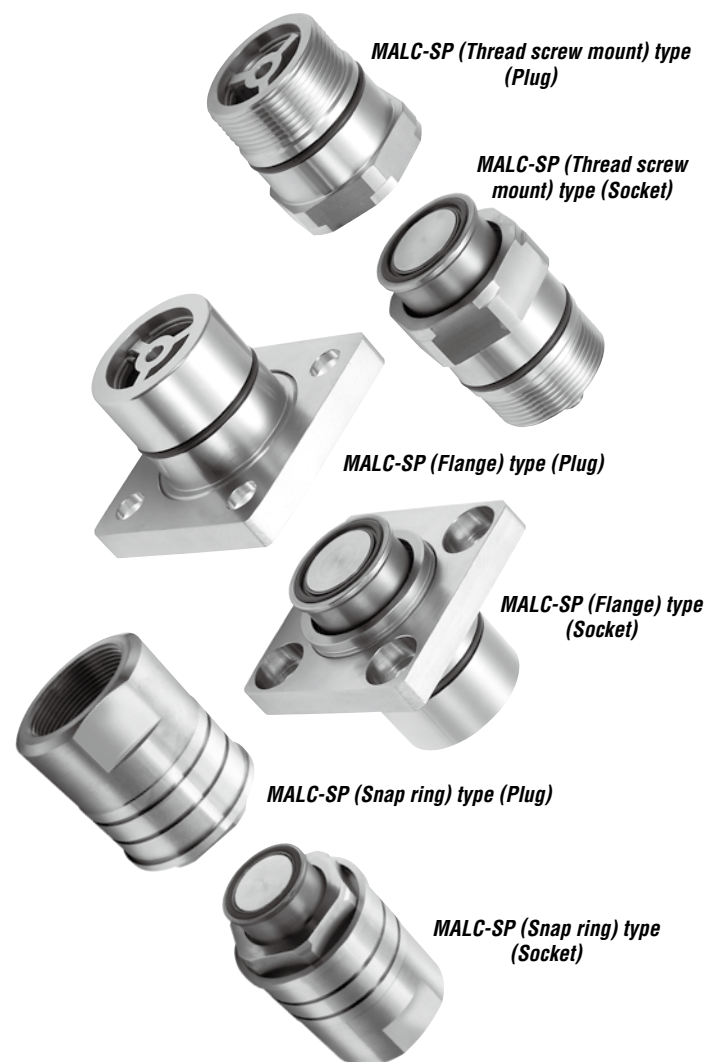

MALC-SP (Thread screw mount) type
(Plug)

MALC-SP (Thread screw mount) type (Socket)

MALC-SP (Flange) type (Plug)

MALC-SP (Flange) type (Socket)

MALC-SP (Snap ring) type (Plug)

MALC-SP (Snap ring) type (Socket)

Specifications				
Body material		Socket body: Stainless steel (Autocatalytic nickel-phosphorus coating)		
Model	Thread screw mount	MALC-1SP	MALC-2 to 8SP	MALC-12SP
	Flange	—	MALC-2 to 8SP-FL	—
	Snap ring	—	MALC-8SP-10F	MALC-12SP(-F/-16F)
Working pressure *	MPa	7.0 (2.0)	5.0 (2.0)	1.5 (2.0)
	kgf/cm ²	71 (20)	51 (20)	15 (20)
	bar	70 (20)	50 (20)	15 (20)
	PSI	1020 (290)	725 (290)	218 (290)
Sealing material		Sealing material	Mark	Working temperature range
Working temperature range		Fluoro rubber	FKM (X-100)	-20°C to +180°C

* The value in brackets is working pressure of individual plug or socket.

Max. Tightening Torque								Nm (kgf·cm)	
Model	1SP	2SP	3SP	4SP	6SP	8SP	12SP	12SP-16F	
Thread screw mount	20 (204)	30 (306)	35 (357)	45 (460)	60 (612)	75 (765)	80 (816)	—	
Flange	—	7 (71.5)	7 (71.5)	7 (71.5)	7 (71.5)	23 (235)	—	—	
Snap ring	—	—	—	—	—	260 (2652)	280 (2856)	350 (3570)	

Interchangeability
Socket and plug in the same size can be connected regardless of their end configurations.

Min. Cross-Sectional Area								(mm ²)	
Model	1SP	2SP(-FL)	3SP(-FL)	4SP(-FL)	6SP(-FL)	8SP(-FL/-10F)	12SP(-F/-16F)		
Min. cross-sectional area	26	49.5	87	153	227	347	795		

Suitability for Vacuum
Not suitable for vacuum application in either connected or disconnected condition.

Admixture of Air on Connection								Admixture of air may vary depending upon the usage conditions. (mL)	
Model	1SP	2SP(-FL)	3SP(-FL)	4SP(-FL)	6SP(-FL)	8SP(-FL/-10F)	12SP(-F/-16F)		
Volume of air	0.08	0.14	0.26	0.55	0.95	0.85	1.46		

Volume of Spillage per Disconnection								Volume of spillage may vary depending upon the usage conditions. (mL)	
Model	1SP	2SP(-FL)	3SP(-FL)	4SP(-FL)	6SP(-FL)	8SP(-FL/-10F)	12SP(-F/-16F)		
Volume of spillage	0.08	0.14	0.26	0.55	0.95	0.85	1.46		

Load Required to Maintain Connection When Line Is Pressurized							
Model	1SP	2SP(-FL)	3SP(-FL)	4SP(-FL)	6SP(-FL)	8SP(-FL/-10F)	12SP(-F/-16F)
Maximum acceptable load N (kgf)	2800 {286}	4500 {459}	5600 {571}	10000 {1019}	14000 {1427}	15600 {1591}	8200 {837}
Minimum load required to maintain connection N (kgf) *	$P \times 170 + 85$ ($p \times 1.7 + 8.5$)	$P \times 345 + 180$ ($p \times 3.45 + 18$)	$P \times 460 + 190$ ($p \times 4.6 + 19$)	$P \times 855 + 260$ ($p \times 8.55 + 26$)	$P \times 1160 + 260$ ($p \times 11.6 + 26$)	$P \times 1360 + 310$ ($p \times 13.6 + 31$)	$P \times 2260 + 400$ ($p \times 22.6 + 40$)

* Assign the actual value of pressure [P (MPa), p (kgf/cm²)] to the above formula to calculate the load. Maintain the connection with the minimum load or more, but not more than the maximum acceptable load.

Flow Rate - Pressure Loss Characteristics
[Test conditions] • Fluid : Water • Temperature : 19°C to 25°C

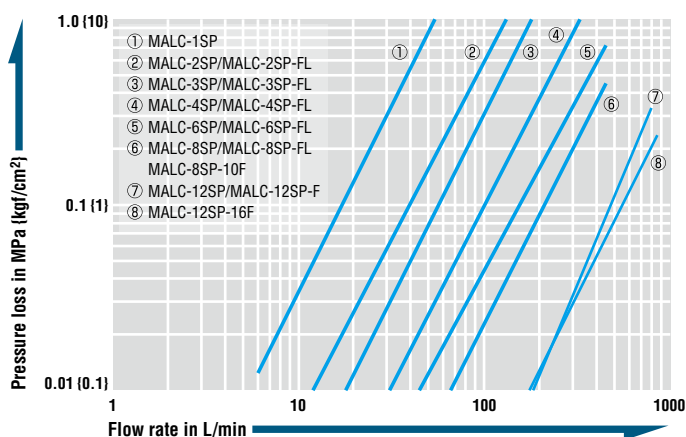

Acceptable distance between socket and plug

Plug and socket must be used in contact with each other. Maximum 0.5 mm distance between socket and plug is acceptable.

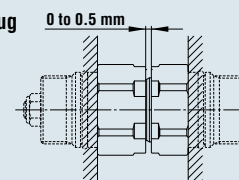

Models and Dimensions

Plug MALC-1 to 12P type (Thread screw mount)

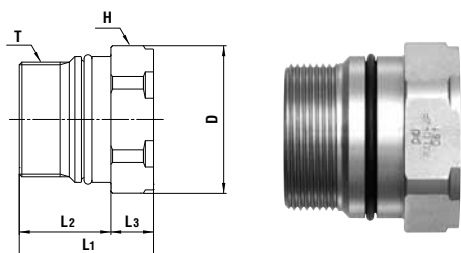

Model	Application	Mass (g)	Dimensions (mm)					
			L1	L2	L3	ϕD	H(WAF)	T
MALC-1P	See P113	40	32	(18)	14	21	Hex.19	M16 x 1
MALC-2P	See P113	75	33	(20)	13	28	Hex.26	M20 x 1.5
MALC-3P	See P113	95	33	(20)	13	32	Hex.29	M24 x 1.5
MALC-4P	See P113	248	41	(28)	13	45	Hex.41	M35 x 1.5
MALC-6P	See P113	369	50.5	(37.5)	13	50	Hex.46	M40 x 2
MALC-8P	See P113	399	53	(41)	12	54	Hex.50	M45 x 2
MALC-12P	See P113	724	57	(45)	12	74	Hex.67	M62 x 2

Socket MALC-1 to 12S type (Thread screw mount)

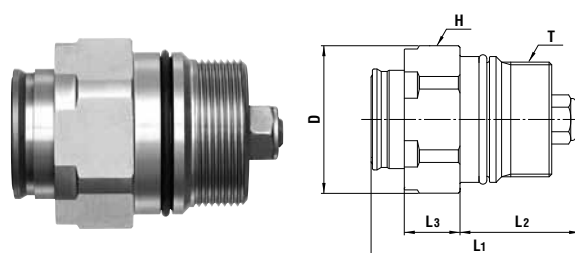

Model	Application	Mass (g)	Dimensions (mm)					
			L1	L2	L3	ϕD	H(WAF)	T
MALC-1S	See P113	53	(45)	(23)	16	21	Hex.19	M16 x 1
MALC-2S	See P113	95	(49)	(26)	17	28	Hex.26	M20 x 1.5
MALC-3S	See P113	120	(51)	(26)	17	32	Hex.29	M24 x 1.5
MALC-4S	See P113	306	(64)	(36.5)	17	45	Hex.41	M35 x 1.5
MALC-6S	See P113	471	(78.5)	(47.5)	17	50	Hex.46	M40 x 2
MALC-8S	See P113	590	(86)	(53)	18	54	Hex.50	M45 x 2
MALC-12S	See P113	1176	(98)	(60)	18	74	Hex.67	M62 x 2

Plug MALC-2 to 6P-FL type (With flange)

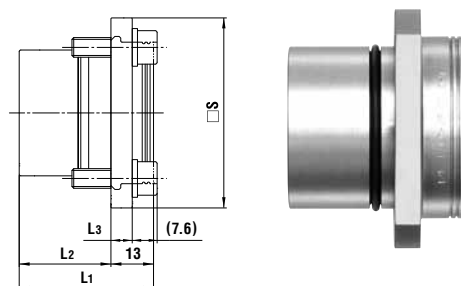

Model	Application	Mass (g)	Dimensions (mm)				
			L1	L2	L3	□ S	
MALC-2P-FL	See P113	146	30	(17)	6	40	
MALC-3P-FL	See P113	180	33	(20)	6	45	
MALC-4P-FL	See P113	390	41	(28)	6.5	58	
MALC-6P-FL	See P113	553	50.5	(37.5)	6.5	64	

Socket MALC-2 to 6S-FL type (With flange)

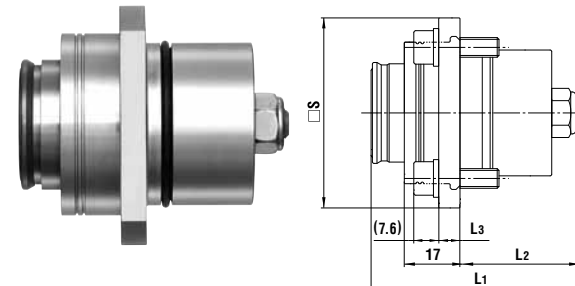

Model	Application	Mass (g)	Dimensions (mm)				
			L1	L2	L3	□ S	
MALC-2S-FL	See P113	173	(49)	(26)	6	40	
MALC-3S-FL	See P113	208	(51)	(26)	6	45	
MALC-4S-FL	See P113	449	(64)	(36.5)	6.5	58	
MALC-6S-FL	See P113	663	(78.5)	(47.5)	6.5	64	

Plug MALC-8P-FL type (With flange)

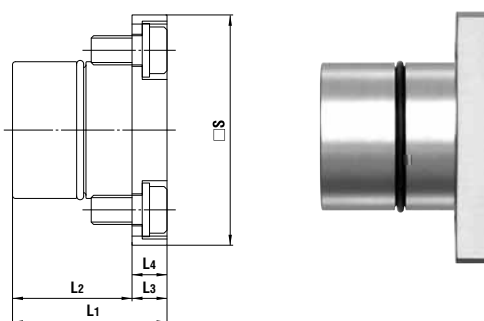

Model	Application	Mass (g)	Dimensions (mm)				
			L1	L2	L3	L4	□ S
MALC-8P-FL	See P113	796	53	(41)	12	12	79

Socket MALC-8S-FL type (With flange)

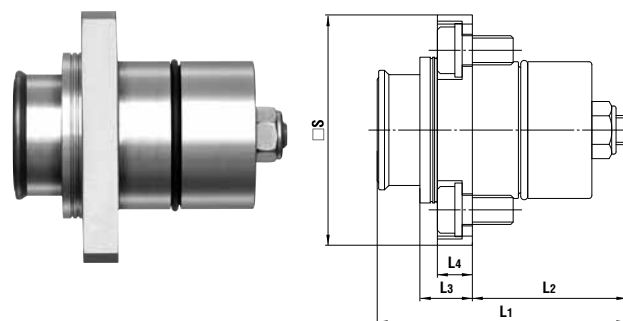

Model	Application	Mass (g)	Dimensions (mm)				
			L1	L2	L3	L4	□ S
MALC-8S-FL	See P113	978	(86)	(53)	18	12	79

Plug MALC-8 / 12P type (With snap ring)

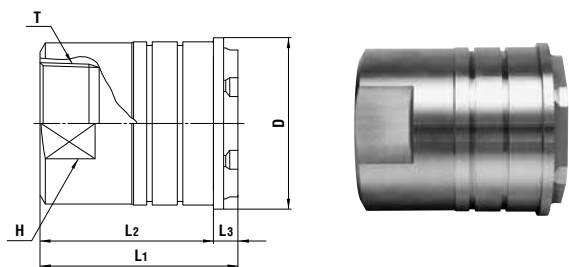

Model	Application	Mass (g)	Dimensions (mm)					
			L1	L2	L3	øD	H(WAF)	T
MALC-8P-10F	See drawings below.	1182	(87)	75	(12)	64	54	Rc 1 1/4
MALC-12P-F		2054	(97)	85	(12)	84	58	Rc 1 1/2
MALC-12P-16F		2128	(97)	85	(12)	84	71	Rc 2

Socket MALC-8 / 12S type (With snap ring)

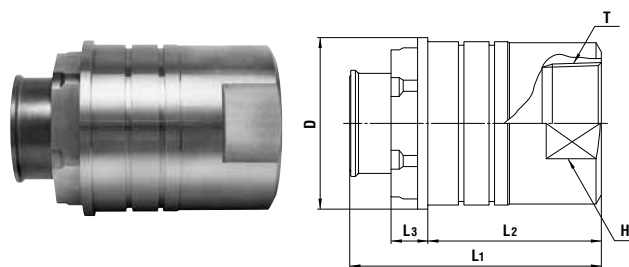

Model	Application	Mass (g)	Dimensions (mm)					
			L1	L2	L3	øD	H(WAF)	T
MALC-8S-10F	See drawings below.	1373	(108)	75	(18)	64	54	Rc 1 1/4
MALC-12S-F		2505	(123)	85	(18)	84	58	Rc 1 1/2
MALC-12S-16F		2579	(123)	85	(18)	84	71	Rc 2

Dimensions of End Configurations

MALC-1 to 12SP type (Thread screw mount)

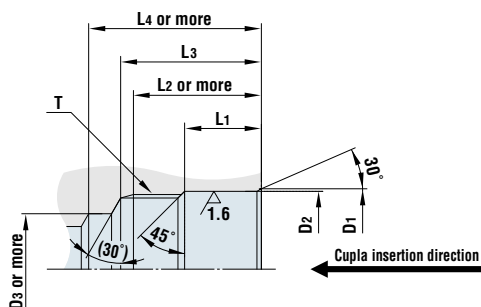

Model	Dimensions (mm)							T
	øD1	øD2	øD3	L1	L2	L3	L4	
MALC-1S	18.3 ^{+0.1} ₀	17.3 ^{+0.06} ₀	13	11	20	22	25	M16 x 1
MALC-1P								
MALC-2S	24 ^{+0.1} ₀	23 ^{+0.06} ₀	16	11.5	22	25	28	M20 x 1.5
MALC-2P								
MALC-3S	27.6 ^{+0.1} ₀	26.6 ^{+0.08} ₀	18	11	22	25	29	M24 x 1.5
MALC-3P								
MALC-4S	39.5 ^{+0.1} ₀	38.5 ^{+0.08} ₀	26	15.5	30	33	40.5	M35 x 1.5
MALC-4P								
MALC-6S	45 ^{+0.1} ₀	44 ^{+0.08} ₀	30	20	40	44	51.5	M40 x 2
MALC-6P								
MALC-8S	48 ^{+0.3} ₀	47 ^{+0.08} ₀	35	27	43	47	55	M45 x 2
MALC-8P								
MALC-12S	66 ^{+0.3} ₀	64 ^{+0.1} ₀	45	30	50	54	65	M62 x 2
MALC-12P								

MALC-2 to 8SP-FL type (With flange)

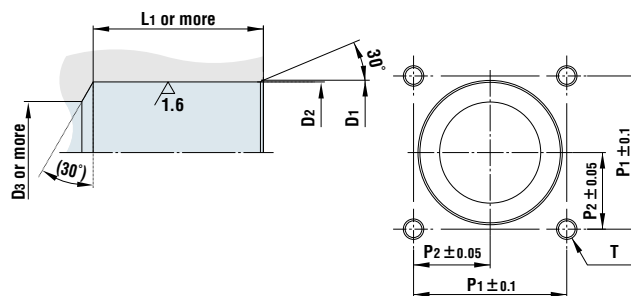

Model	Dimensions (mm)						
	øD1	øD2	øD3	L1	P1	P2	T
MALC-2S-FL	24 ^{+0.1} ₀	23 ^{+0.06} ₀	16	28	28	14	4 x M6 Thread depth 17 mm or more
MALC-2P-FL				19			
MALC-3S-FL	27.6 ^{+0.1} ₀	26.6 ^{+0.08} ₀	18	28	31	15.5	
MALC-3P-FL				22			
MALC-4S-FL	39.5 ^{+0.1} ₀	38.5 ^{+0.08} ₀	26	39	40	20	4 x M10 Thread depth 15 mm or more
MALC-4P-FL				30.5			
MALC-6S-FL	45 ^{+0.1} ₀	44 ^{+0.08} ₀	30	50	45	22.5	
MALC-6P-FL				40			
MALC-8S-FL	48 ^{+0.3} ₀	47 ^{+0.08} ₀	35	53	55	27.5	
MALC-8P-FL				43			

MALC-8 / 12P type (With snap ring)

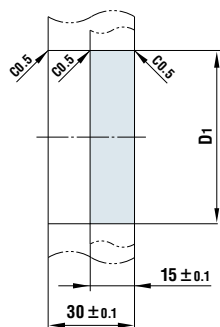

Plate with 15 mm or 30 mm thickness can be mounted.

Model	Dimensions (mm)	
	øD1	
MALC-8S-10F	60.1 ^{+0.1} ₀	
MALC-8P-10F		
MALC-12S-F	80.1 ^{+0.1} ₀	
MALC-12P-F		
MALC-12S-16F	80.1 ^{+0.1} ₀	
MALC-12P-16F		